

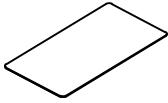

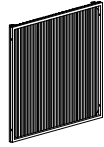



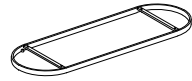

ASSEMBLY INSTRUCTIONS

DT2025-B1
DT2025-B2
DT2025-B3

PARTS LIST

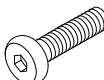
A Table top  1 PC	B Wing Panel  2 PCS	C Pedestal  2 PCS	D Base Ring  1 PC
---	---	--	---

HARDWARE LIST

1  Bolt(1/4" x 7/8") 10PCS	2  Bolt (1/4" x 1-1/4") 8PCS	3  Spring Washer (1/4") 18 PCS
4  Washer(1/4"xØ16) 18PCS	5  Allen Wrench(4mm) 1PC	

Step 1

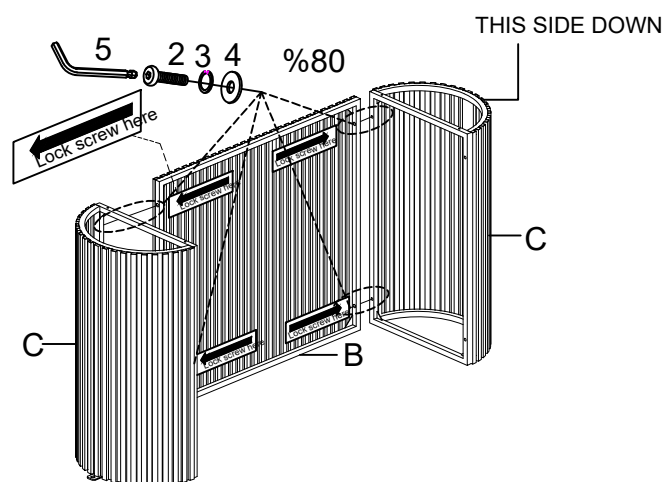

In this step, tighten the screws to 80%.
Note: Do not lock the screws.

ASSEMBLY INSTRUCTIONS

DT2025-B1
DT2025-B2
DT2025-B3

Step 2

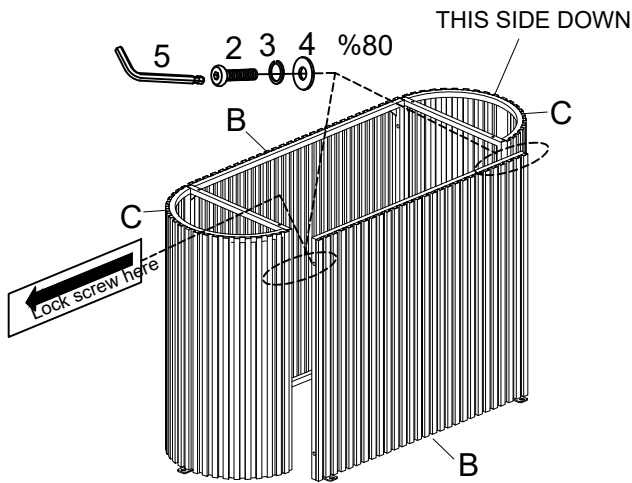

In this step, tighten the screws to 80%.
Note: Do not lock the screws.

Step 3

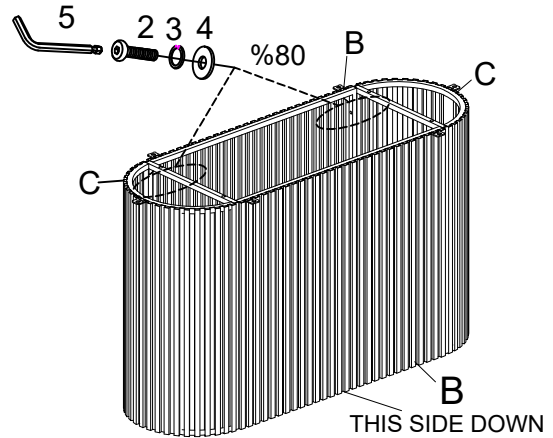

With the assistance of an adult partner, place the base upside down. Then, lock the Wing Panel (B) and Pedestal (C).
In this step, tighten the screws to 80%.
Note: Do not lock the screws.

Step 4

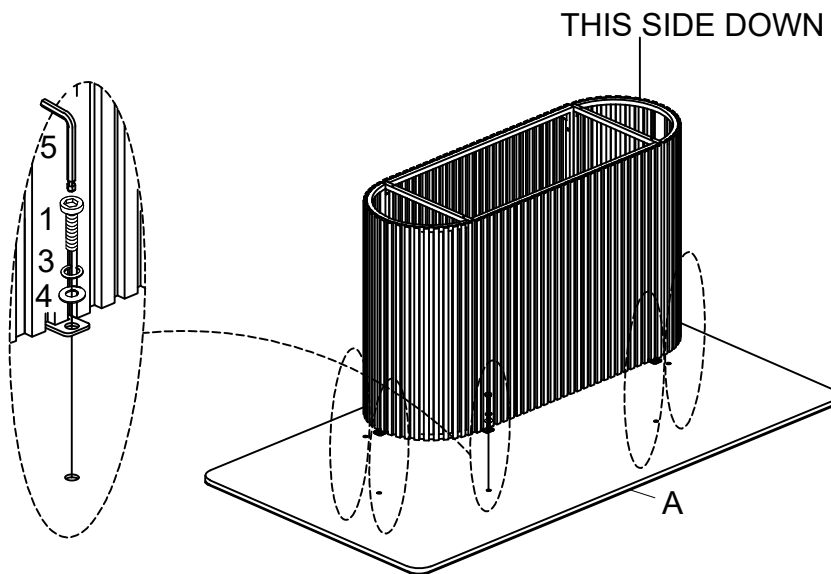

Place the tabletop facedown on a clean, non-marring surface. Attach the table base to the bottom of the tabletop using screws, as shown in the pictures.
Attention: When locking the tabletop, please use Short Bolt(1).

ASSEMBLY INSTRUCTIONS

DT2025-B1
DT2025-B2
DT2025-B3

Step 5

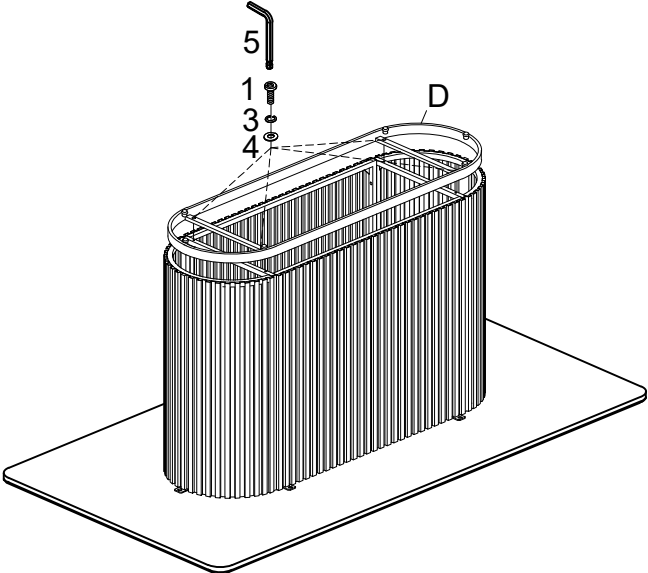

Step 6

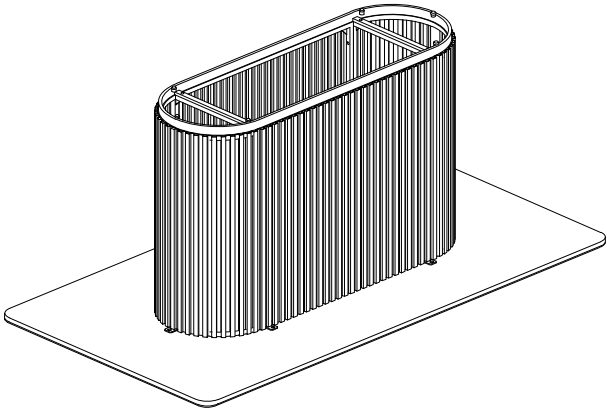

Note: Fully tighten all bolts at this step.

Step 7

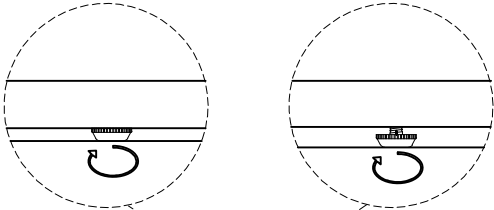
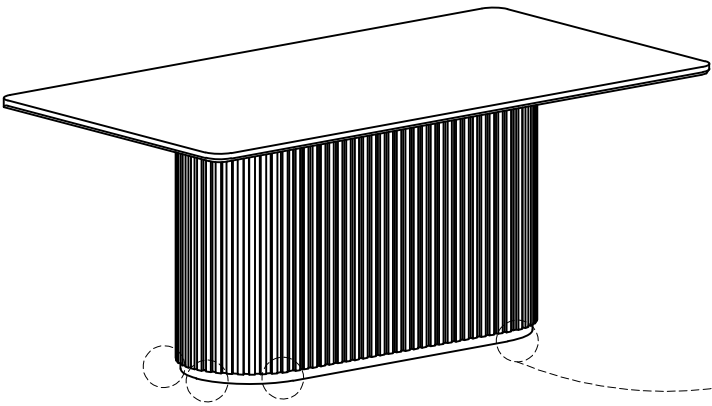

Adjust Pre-installed Levelers height to achieve balance