





CARE AND MAINTENANCE

Wipe clean with a soft, dry cloth. The seat board can be cleaned with a mild cleaner. Test the cleaning method on a hidden area before using them over the entire area.

NOTICE

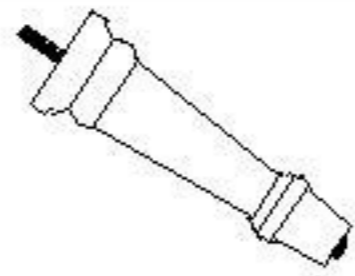
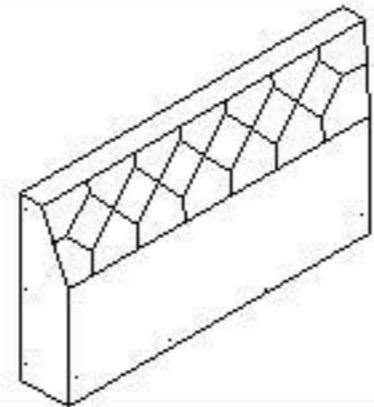
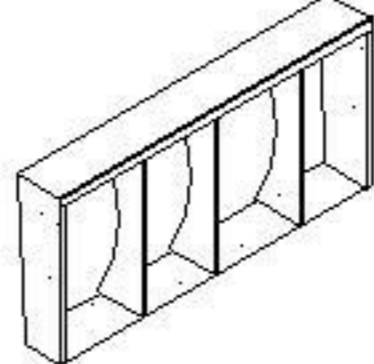
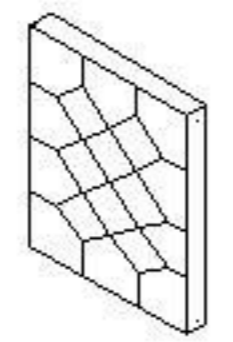
- * Please make sure that you have all parts indicated before you begin assembly of this item.
- * This item should be assembled on a soft surface to prevent scratching the finish during assembly.
- * This item may require periodic tightening.
- * Do not tighten bolts until completely assembled.

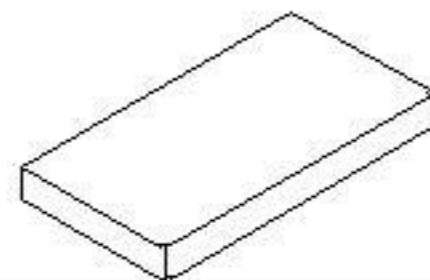
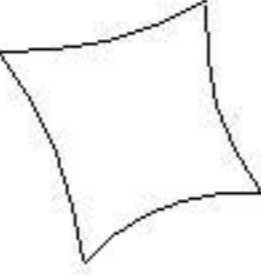
Part List and Hardware List

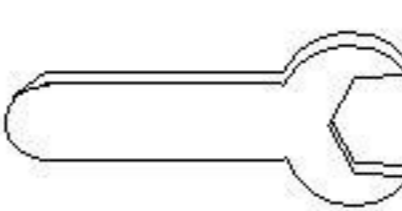
Piece	Description	Picture	Quantity
A	LEG		4 X
B	CHAIR BACK		1 X
C	SEAT FRAME		1 X
D	LEFT SIDE ARMREST		1 X
E	RIGHT SIDE ARMREST		1 X
F	SEAT CUSHION		1 X
G	PILLOW		2 X
H1	BOLT		16 X
H2	WRENCH		1 X

Product Dimensions:

Loveseat: 53"W*28-3/4"D*31-1/2"H

Pillow: 18"W*18"H

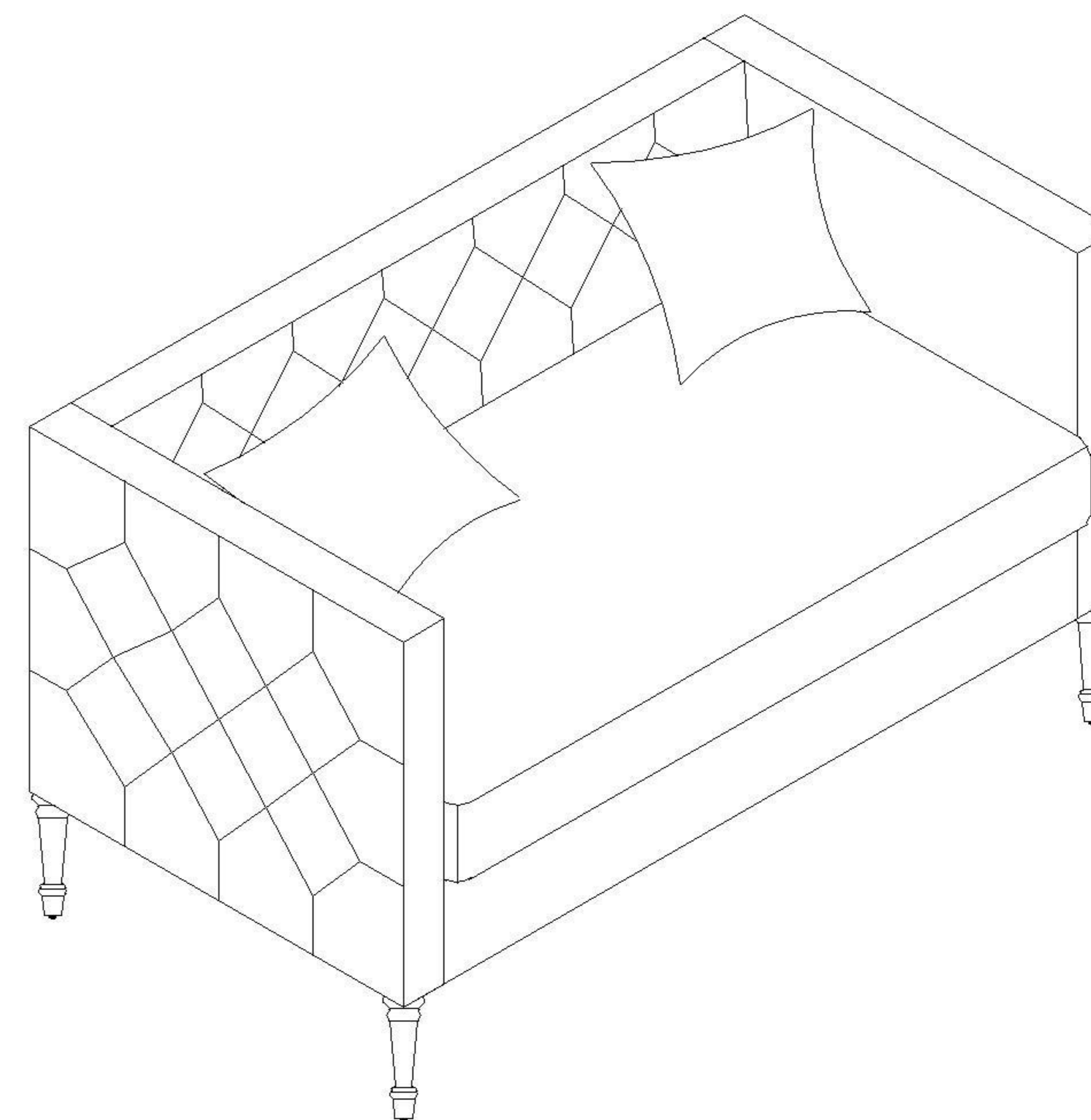

PREPARATION

Before beginning assembly of product, make sure all parts are present. Compare parts with package contents list and hardware contents list. If any part is missing or damaged, do not attempt to assemble the product.

Estimated Assembly Time: 15 minutes.

Tools Required for Assembly (included): Wrench.

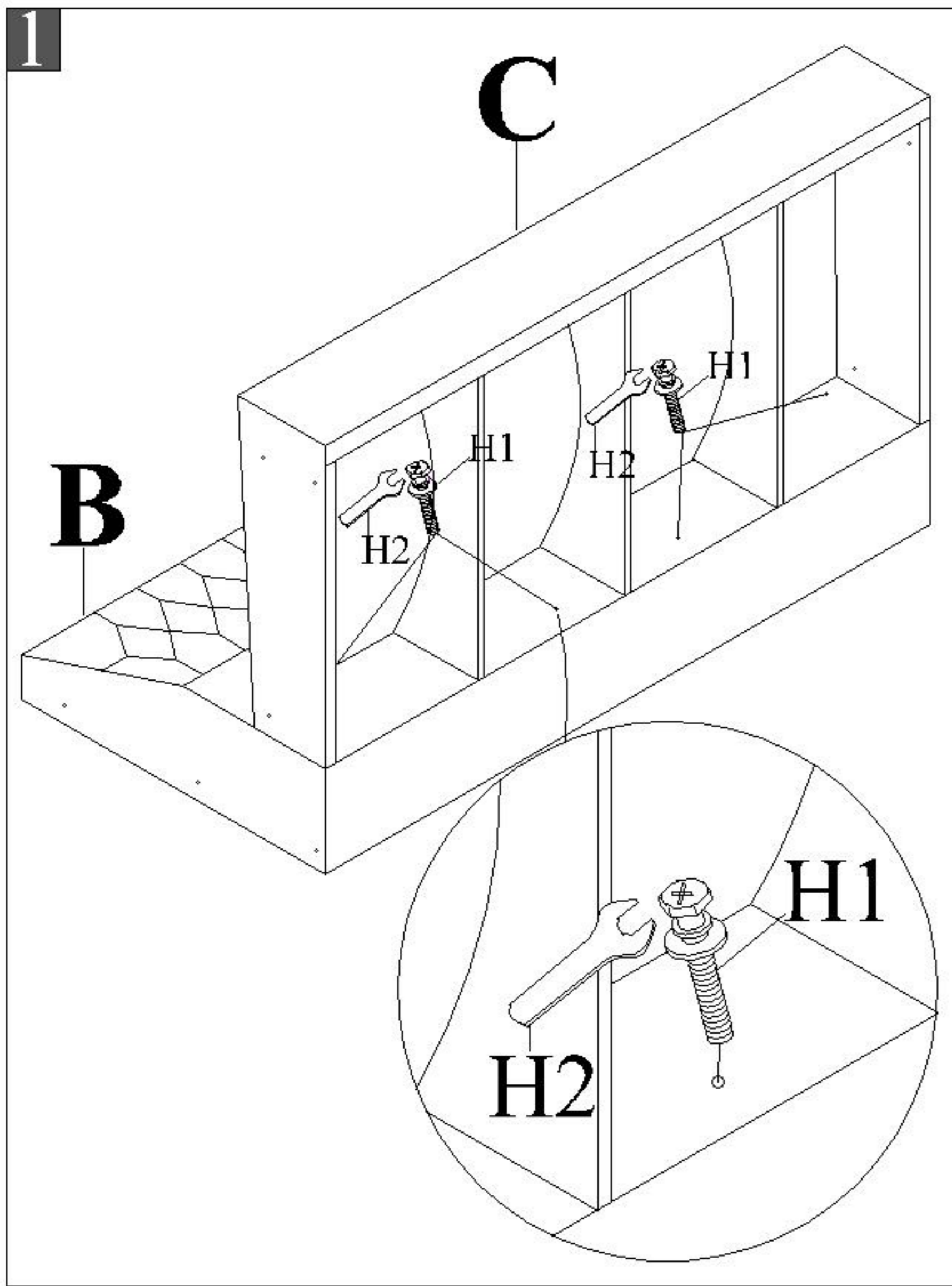

Step 1
Place the seat frame with the chair back together as picture. Then use the "wrench" to lock 4 bolts "H1".

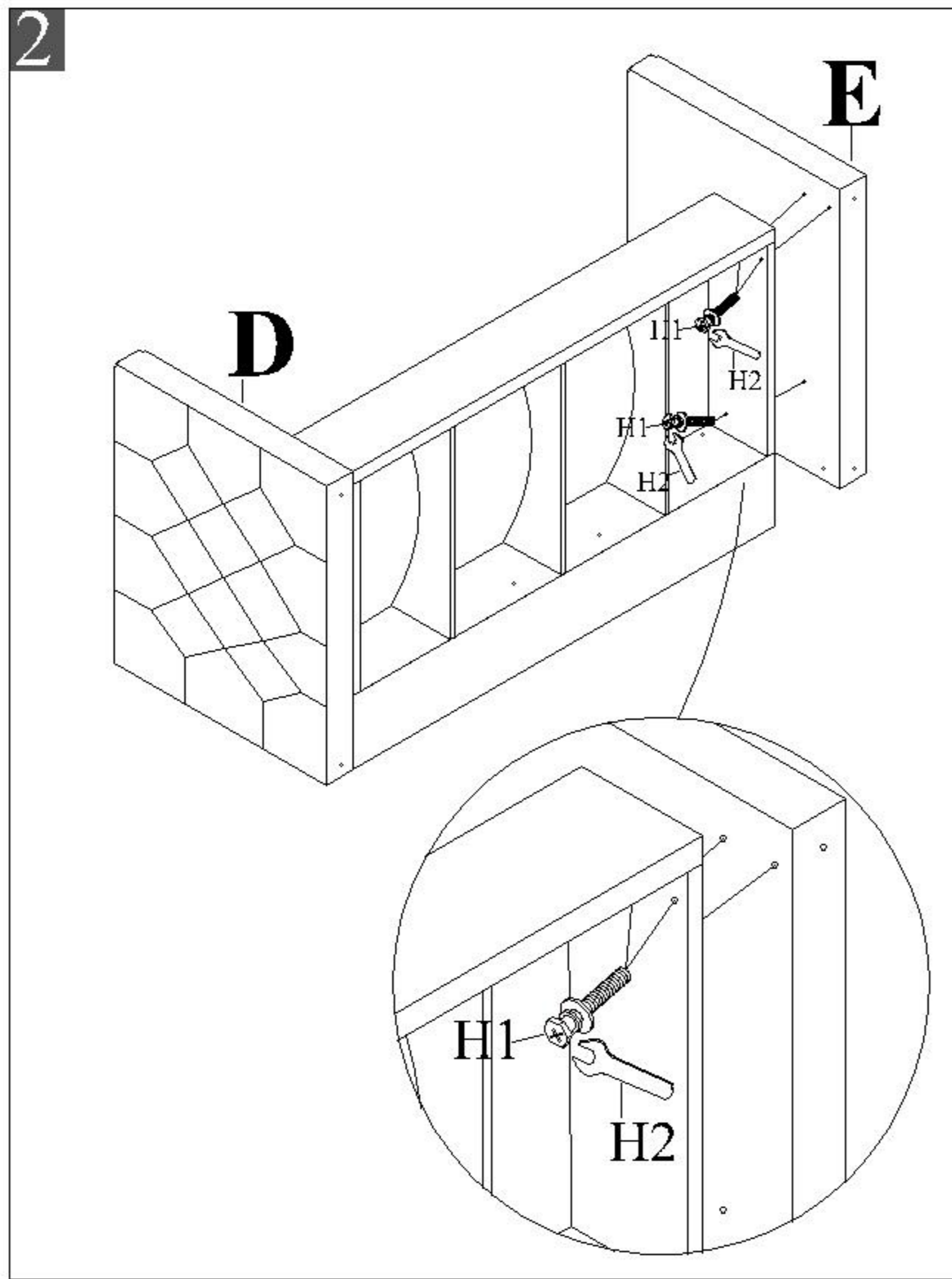

Step 2
Attach the left(D)/right(E) side armrest with seat frame. Then use the "wrench" to lock 6 bolts "H1".

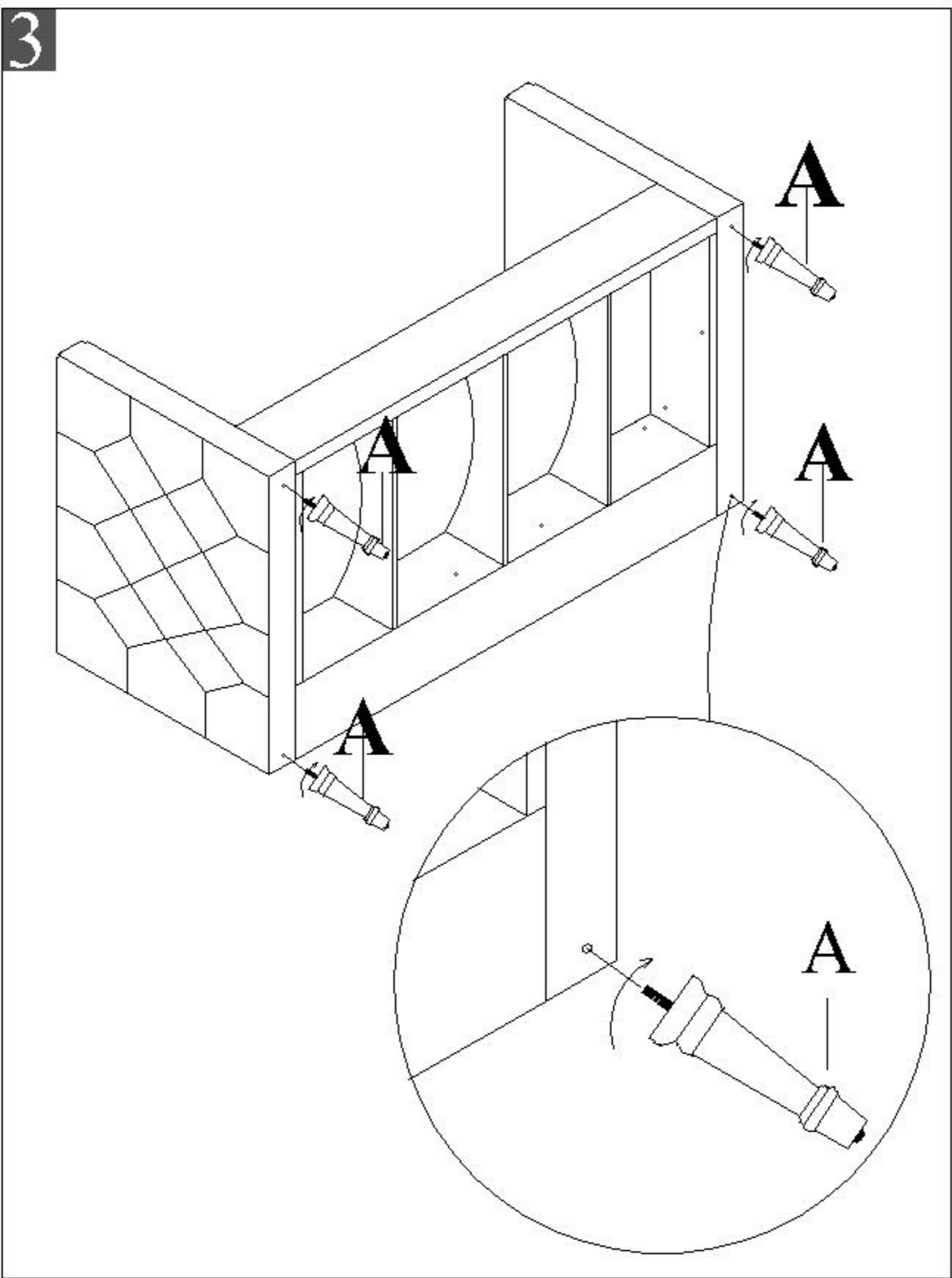

Step 3
Assembly 4 legs to bottom side of the left/right side armrest.

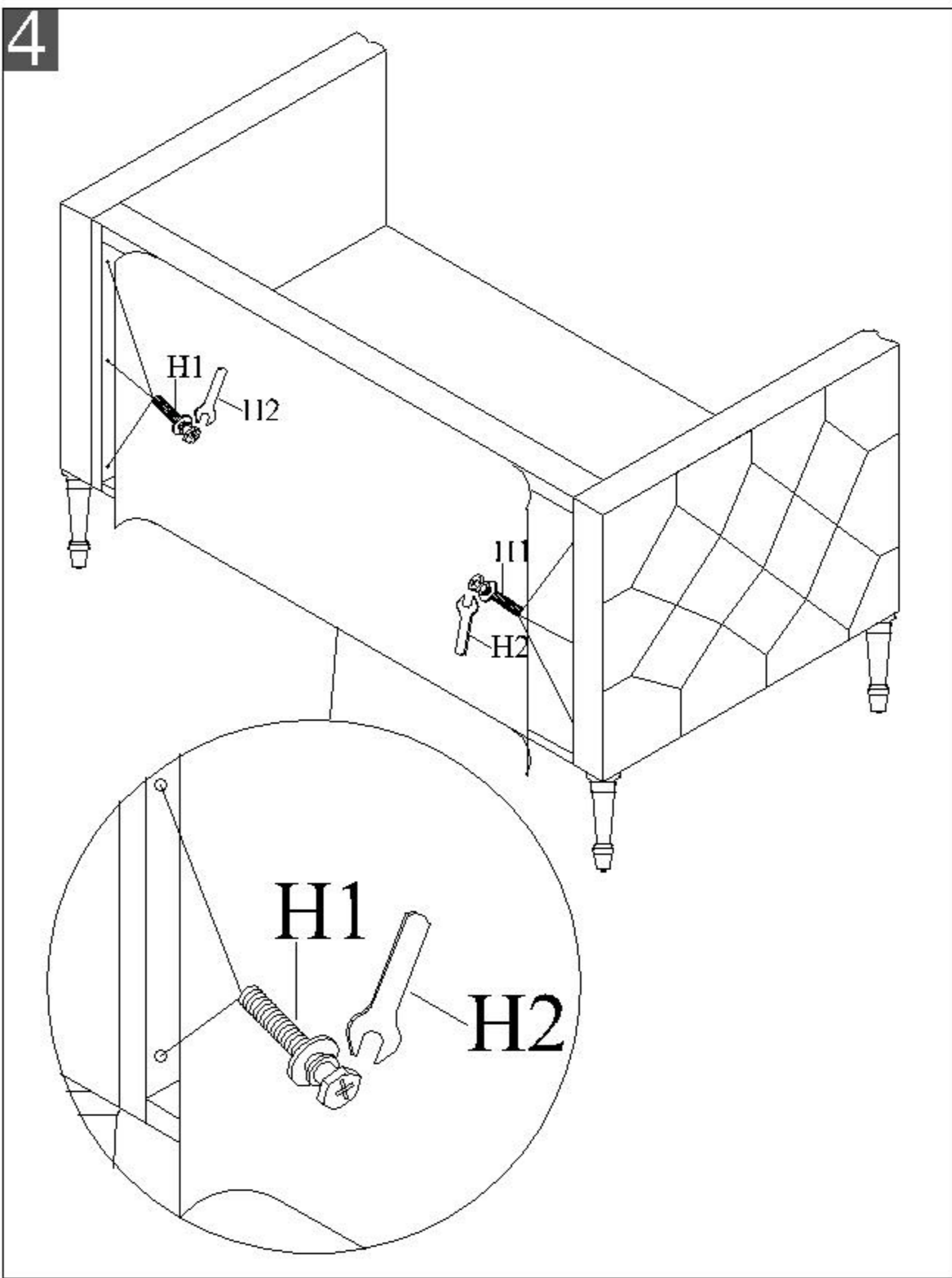

Step 4
Use "wrench" to lock the 6 bolts "H1" into left/right side armrest with the chair back as picture.

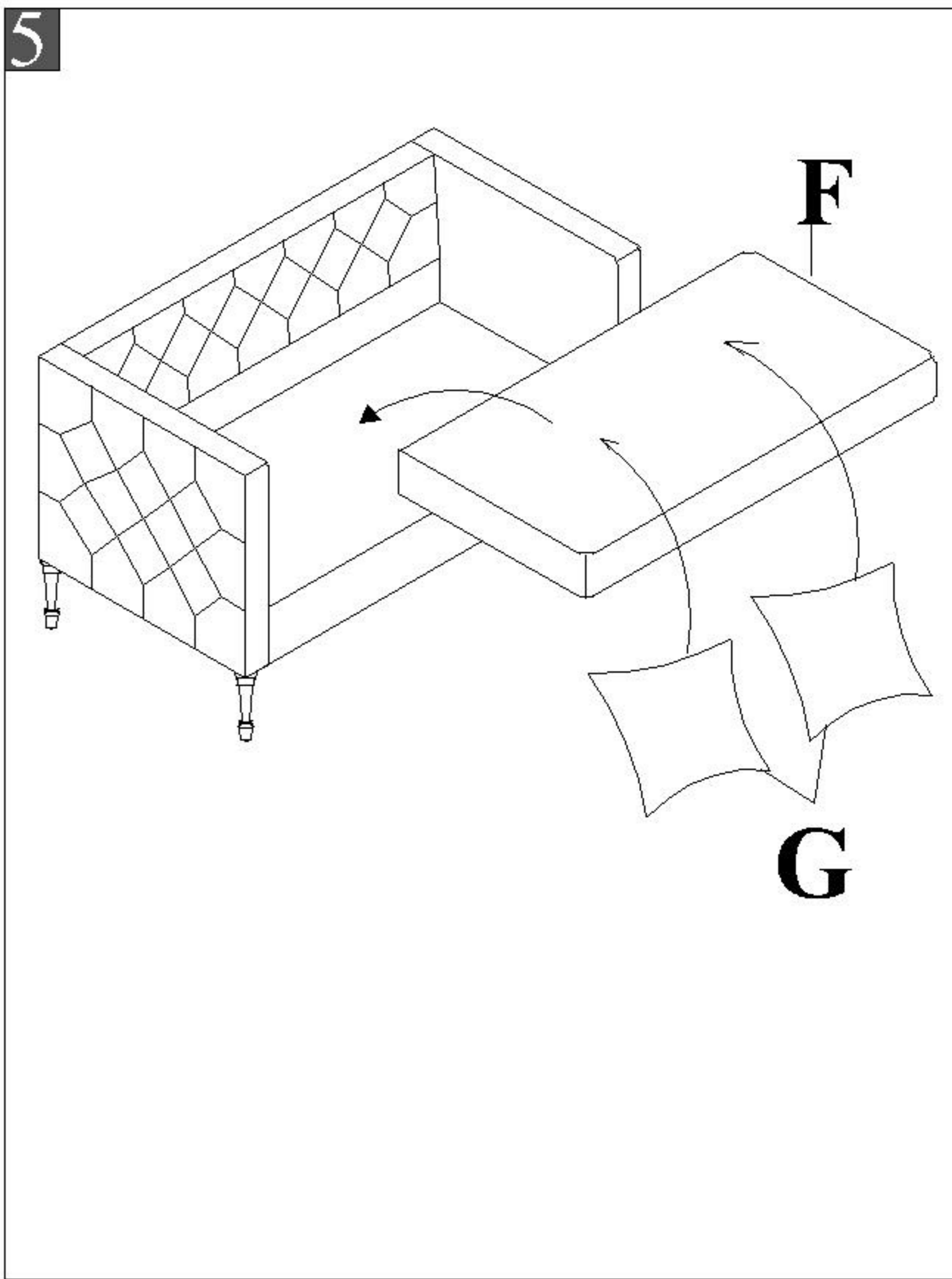

Step 5
Put on the seat cushion and pillows on the seat frame.