

# Assembly Instructions

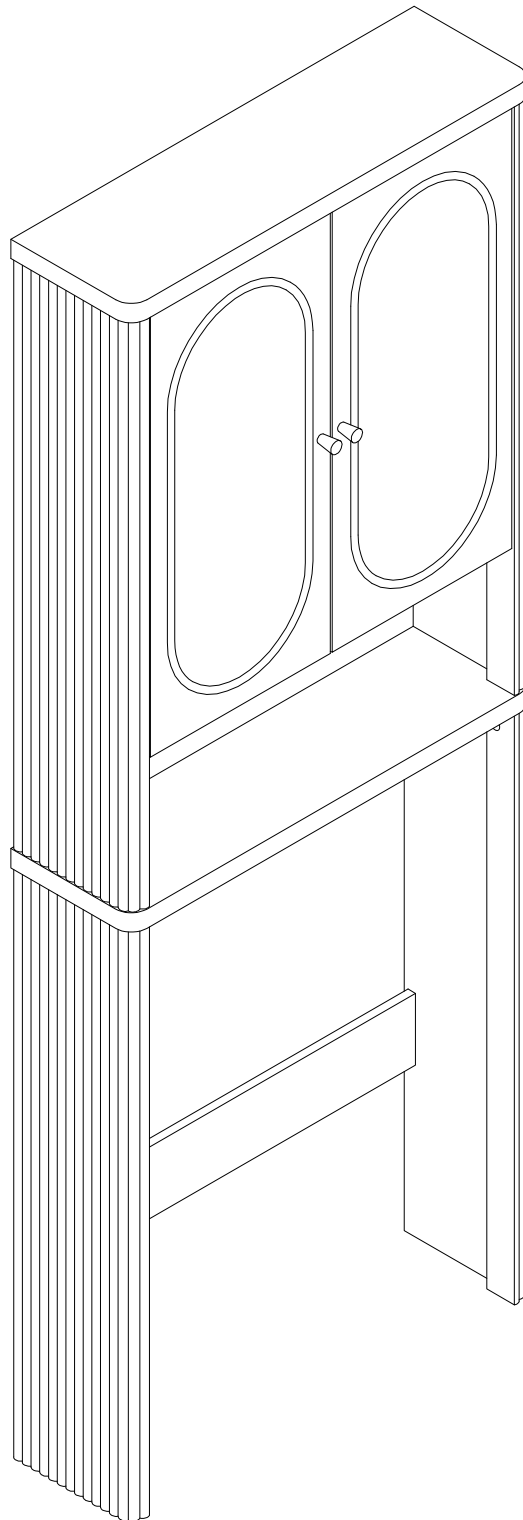

# Before Assembly

## Tips Before Your Start:

- Remove all wrapping material, including staples & packing straps before you start to assemble.
- DO NOT tighten all screws and bolts until the assembly is completely assembled.
- Keep all hardware parts out of reach of children.

## QUICKFIT

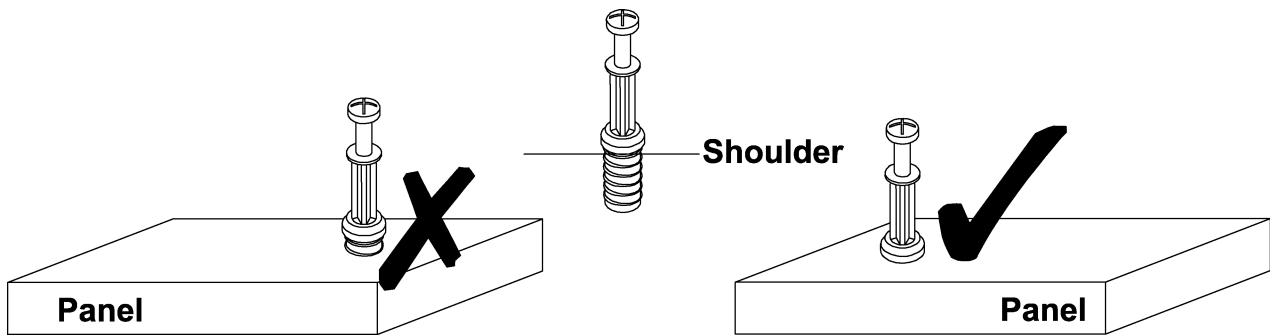

Tighten quickfit until shoulder is flush with panel. Do not overtighten or undertighten.

## CAM LOCK

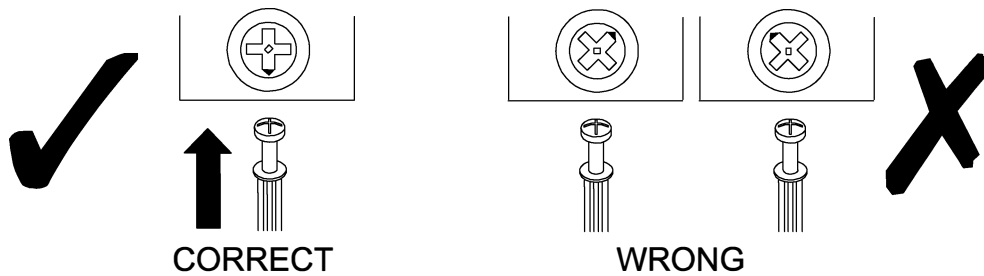

When fitting a cam lock, ensure the starting position is correct before inserting the connecting QUICKFIT





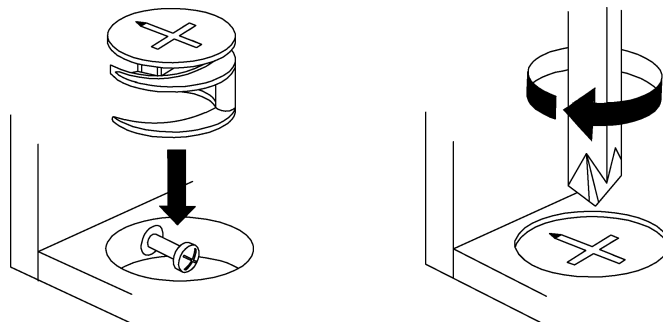



Quickfit head should be in the centre of the cam lock when the two panels are joined.

Cam lock should be inserted before quickfit.

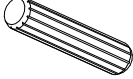

Turn cam lock clockwise to tighten.

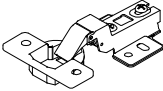
# Part List

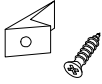
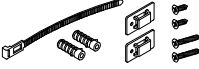
<p><b>No. A</b> Quantity:28 Pcs Cam Lock Dowel 8*28mm</p> 	<p><b>No. B</b> Quantity:28 Pcs Cam φ15</p> 	<p><b>No. C</b> Quantity:28 Pcs Sticker Ø20</p> 	<p><b>No. D</b> Quantity:12 Pcs Dowel 8*30mm</p> 
<p><b>No. E</b> Quantity:24 Pcs Screw 3.5*14mm</p> 	<p><b>No. F</b> Quantity:2 Pcs Screw M4*20mm</p> 	<p><b>No. G</b> Quantity:2 Pcs Handle</p> 	<p><b>No. H</b> Quantity:4 Pcs Hinge</p> 
<p><b>No. I</b> Quantity:6 Pcs Foot Pad Ø15</p> 	<p><b>No. J</b> Quantity:12 Sets Plastic Wedge</p> 	<p><b>No. K</b> Quantity:1 Sets Anti-falling Parts</p> 	

# Product structure

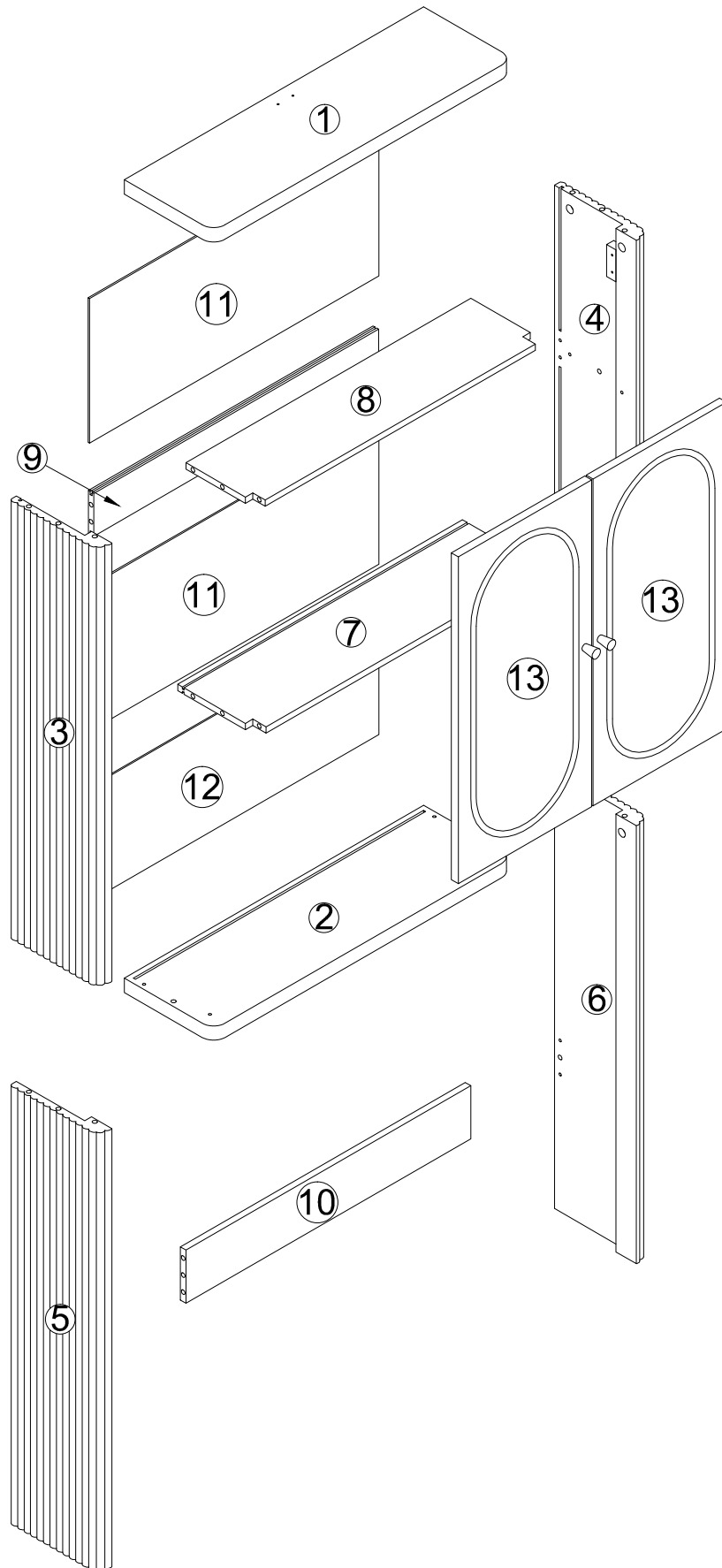

# STEP 1

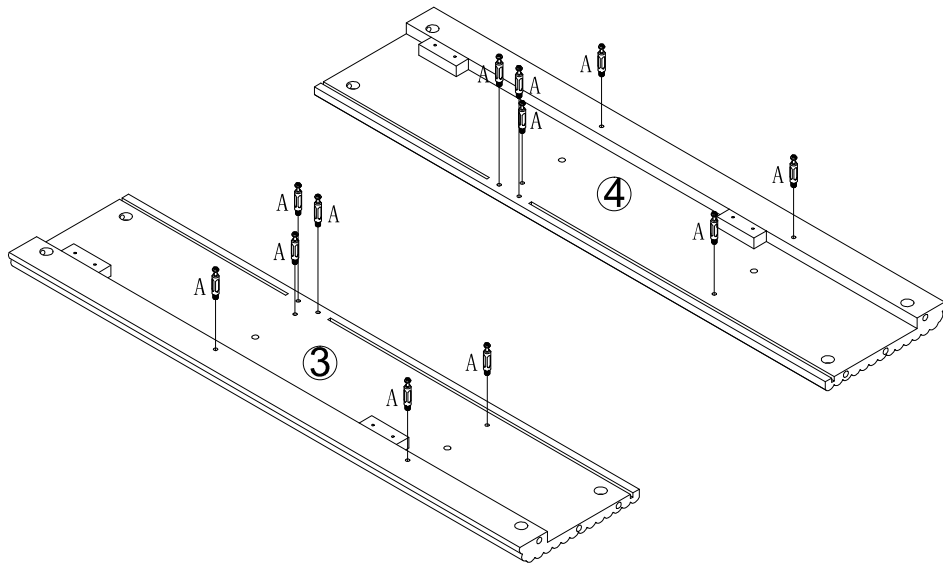

No. A  
Quantity: 12 Pcs  
8\*28 mm



# STEP 2

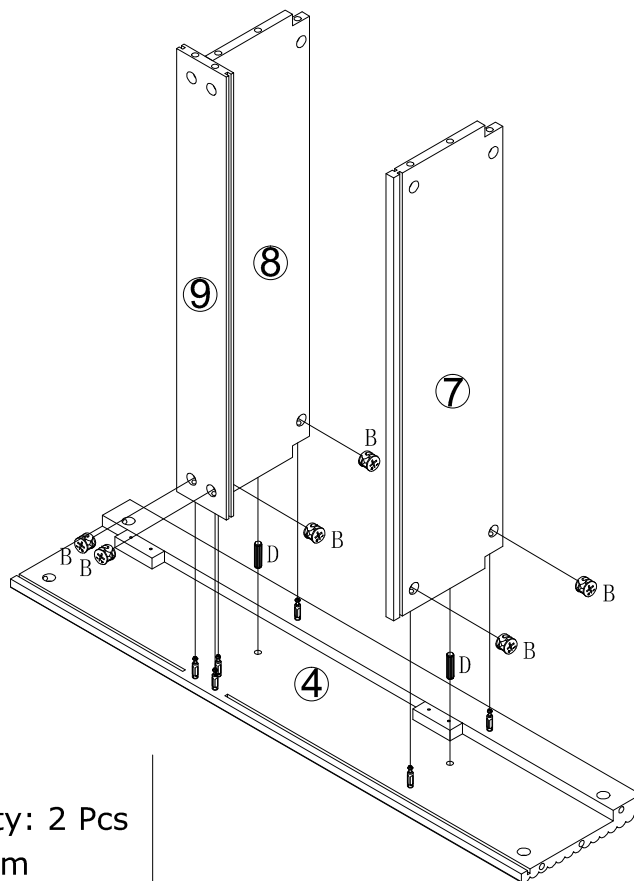

No. B  
Quantity: 6 Pcs  
Ø15



No. D  
Quantity: 2 Pcs  
8\*30mm

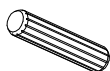

## STEP 3

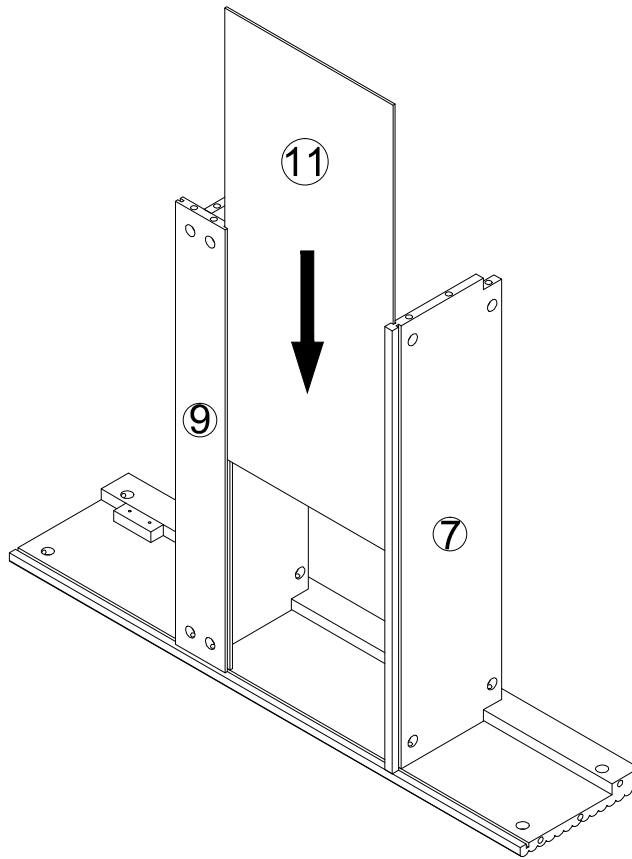

## STEP 4

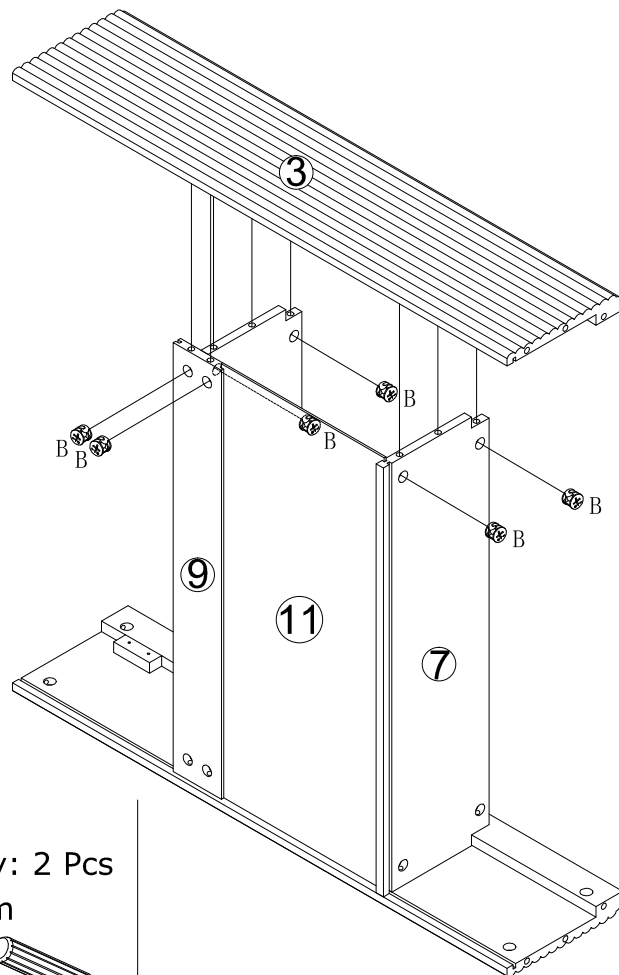

No. B  
Quantity: 6 Pcs  
Ø15



No. D  
Quantity: 2 Pcs  
8\*30mm

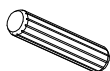

## STEP 5

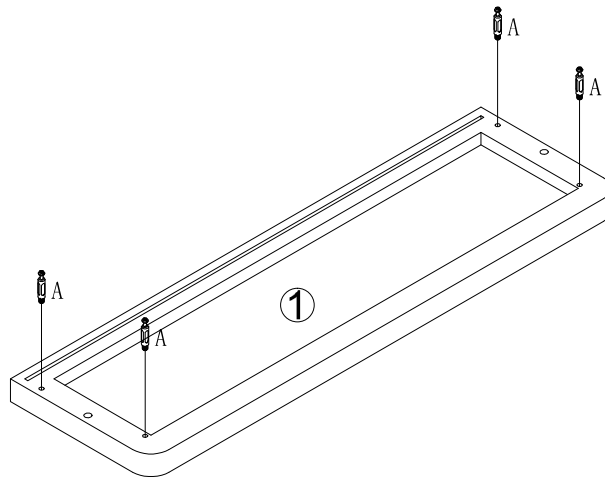

No. A  
Quantity: 4 Pcs  
8\*28 mm



## STEP 6

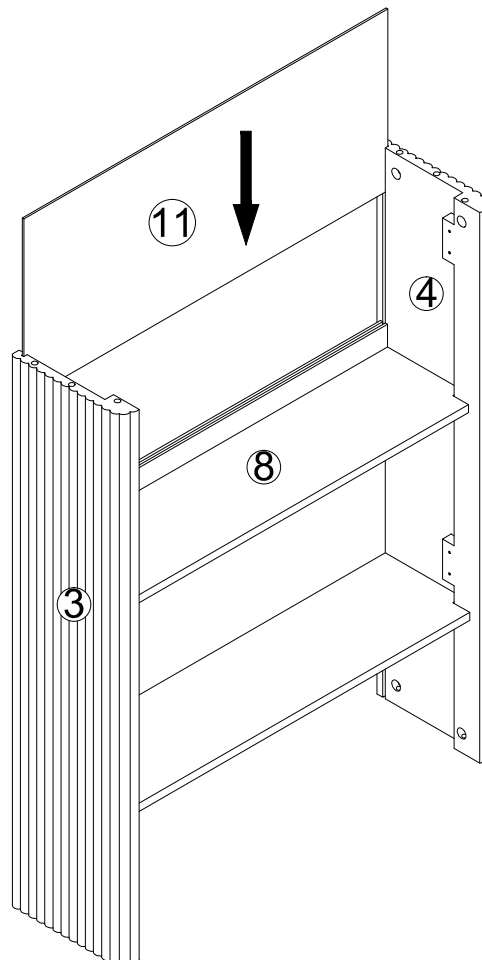

# STEP 7

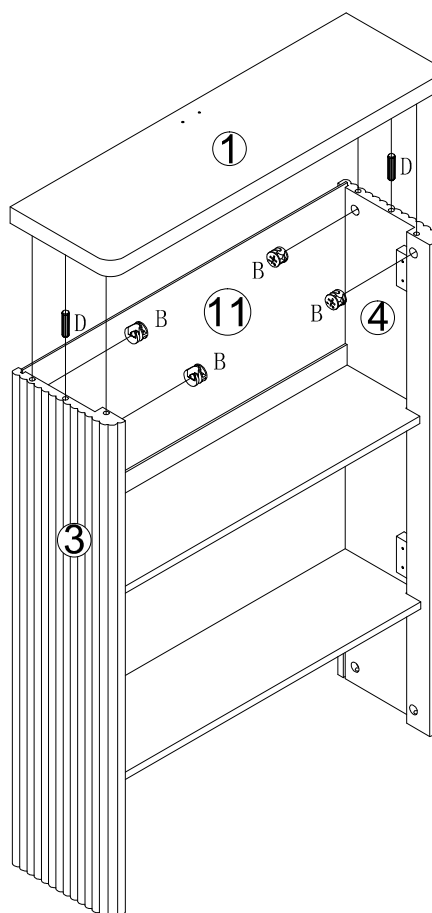

No. B  
Quantity: 4 Pcs  
Ø15



No. D  
Quantity: 2 Pcs  
8\*30mm

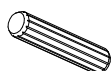

# STEP 8

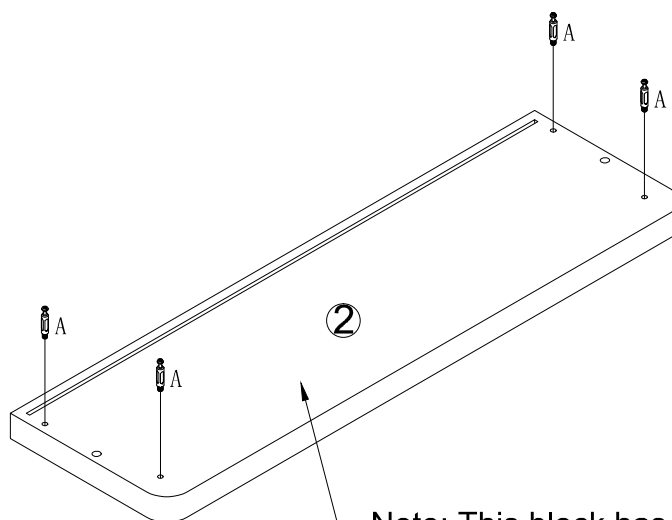

Note: This block has holes on both sides, please pay attention to the difference.

No. A  
Quantity: 4 Pcs  
8\*28 mm



## STEP 9

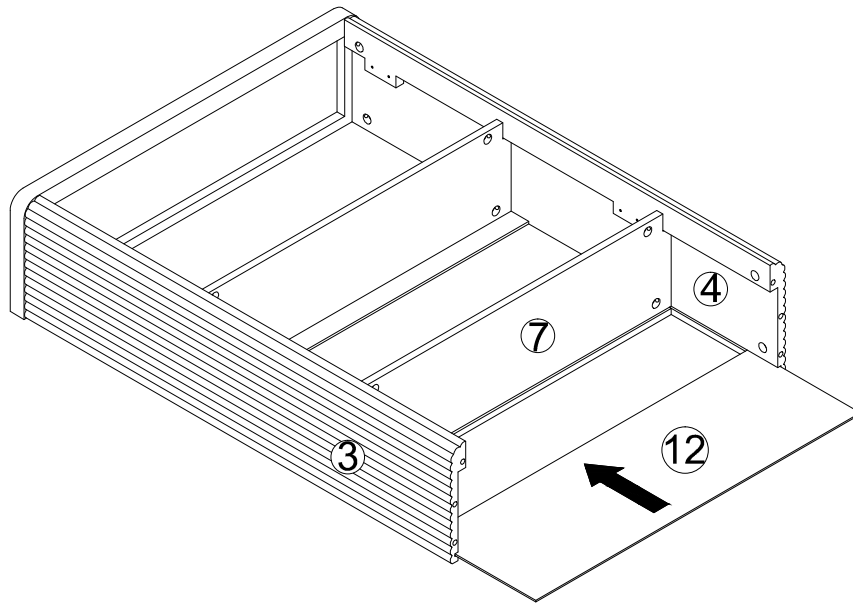

## STEP 10

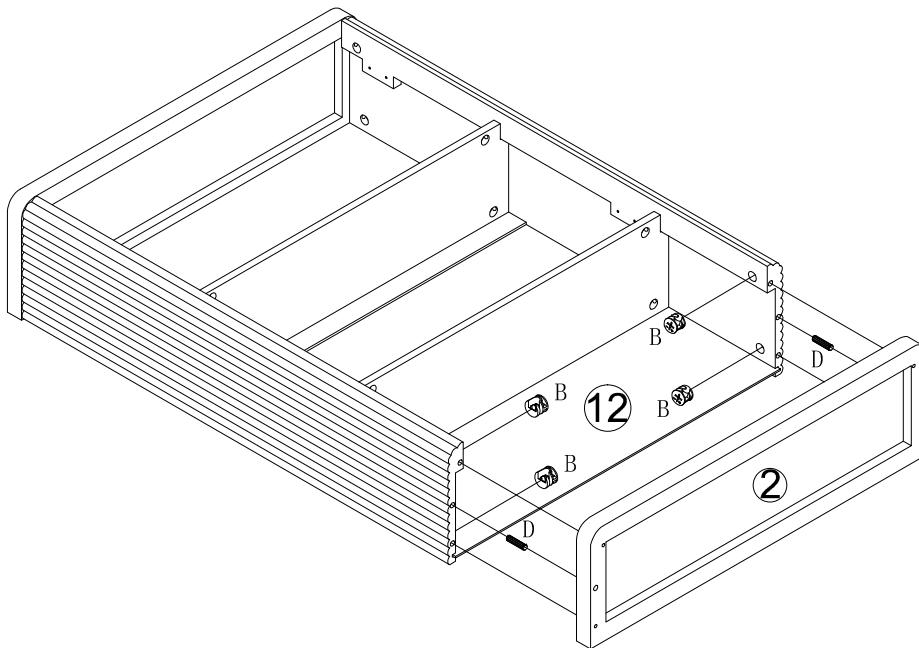

No. B  
Quantity: 4 Pcs  
Ø15



No. D  
Quantity: 2 Pcs  
8\*30mm

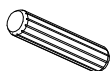

# STEP 11

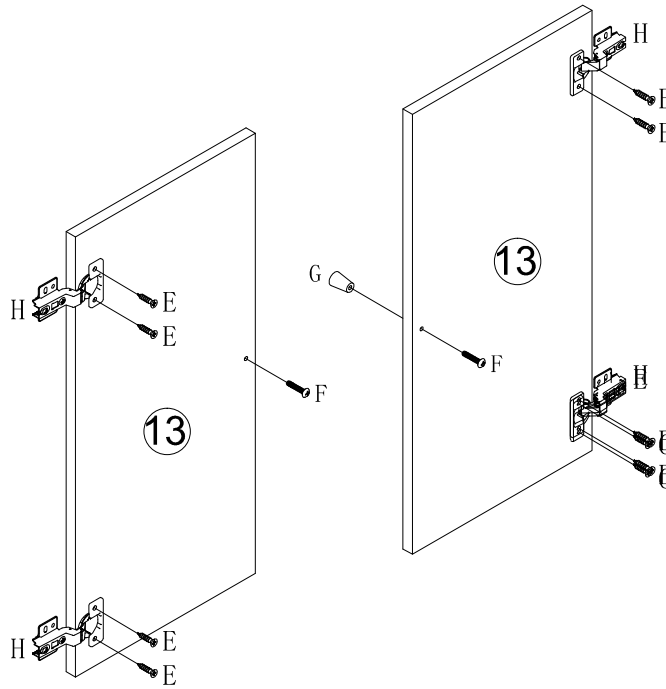

No. E  
Quantity: 8 Pcs  
3.5\*14mm



No. F  
Quantity: 2 Pcs  
M4\*20mm



No. G  
Quantity: 2 Pcs



No. H  
Quantity: 4 Pcs

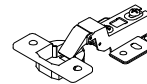

# STEP 12

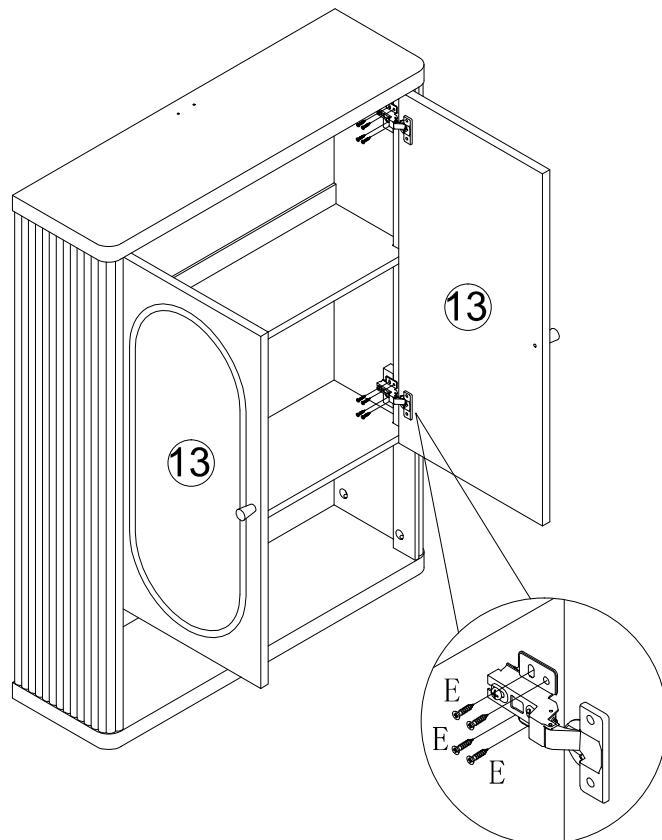
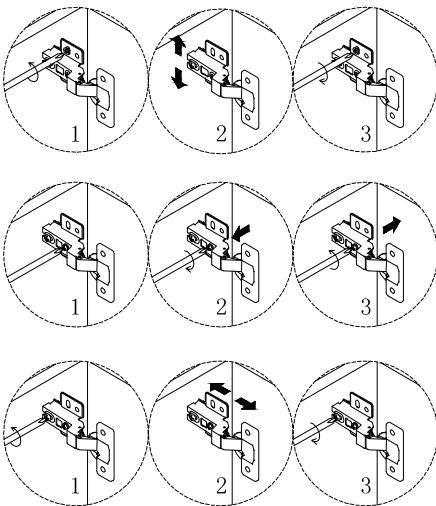

No. E  
Quantity: 16 Pcs  
3.5\*14mm



## STEP 13

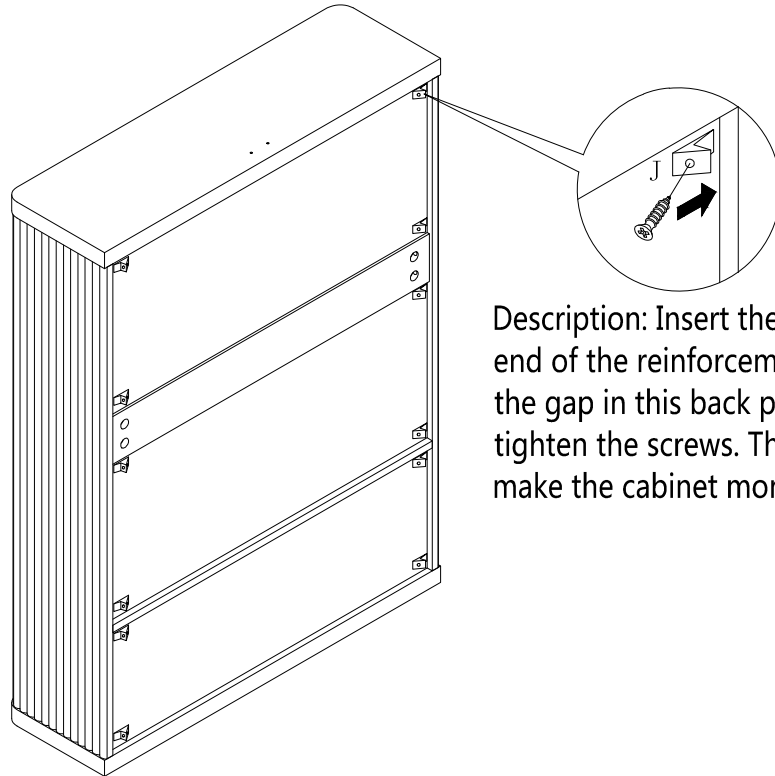

Description: Insert the thinner end of the reinforcement into the gap in this back panel, then tighten the screws. This will make the cabinet more stable.

No. J  
Quantity: 12 Sets

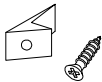

## STEP 14

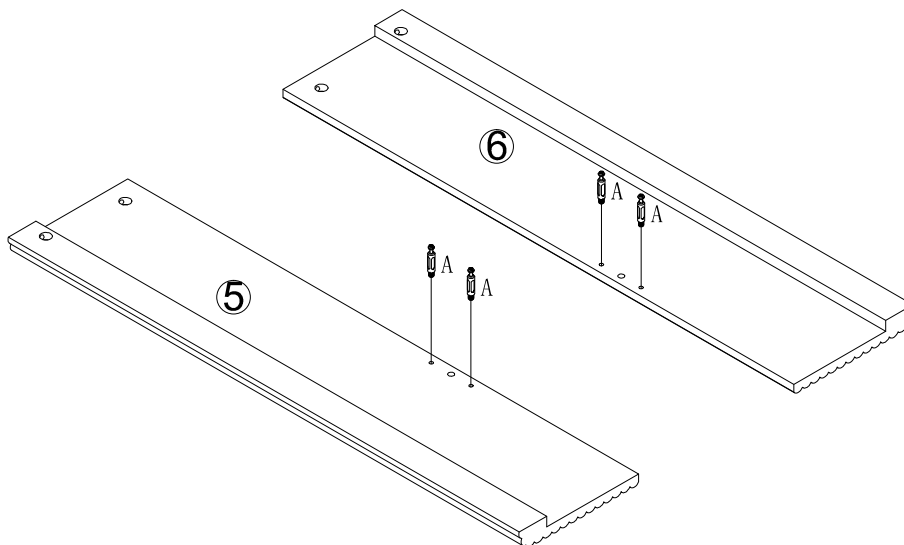

No. A  
Quantity: 4 Pcs  
8\*28 mm



# STEP 15

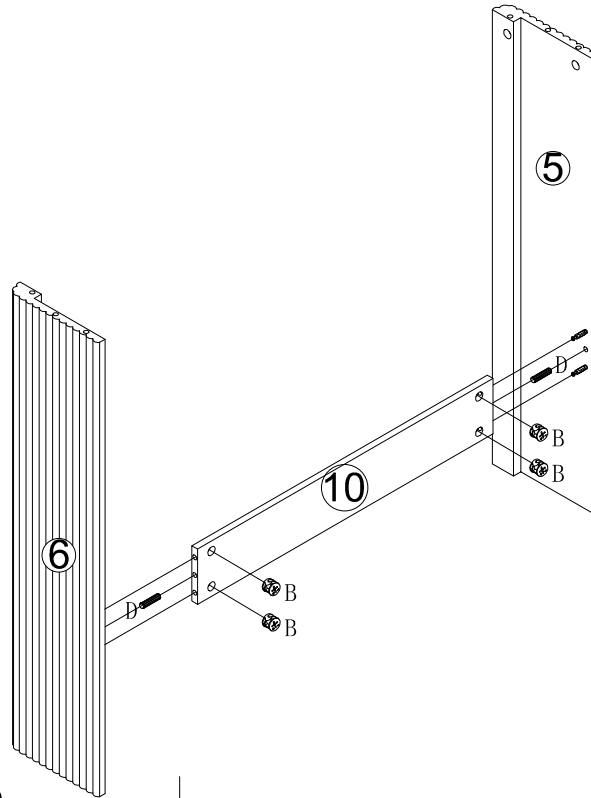

No. B  
Quantity: 4 Pcs  
Ø15



No. D  
Quantity: 2 Pcs  
8\*30mm

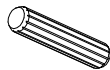

# STEP 16

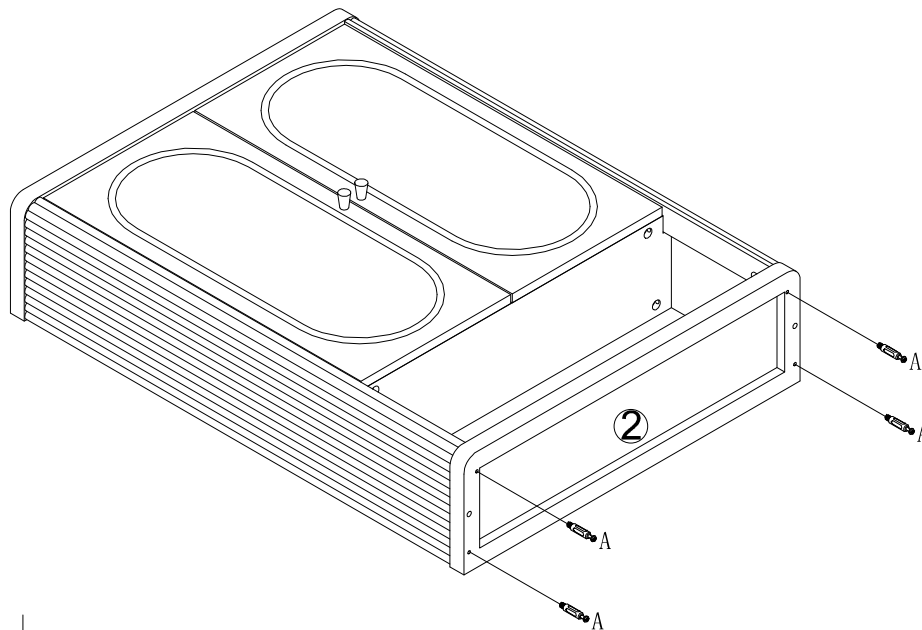

No. A  
Quantity: 4 Pcs  
8\*28 mm



## STEP 17

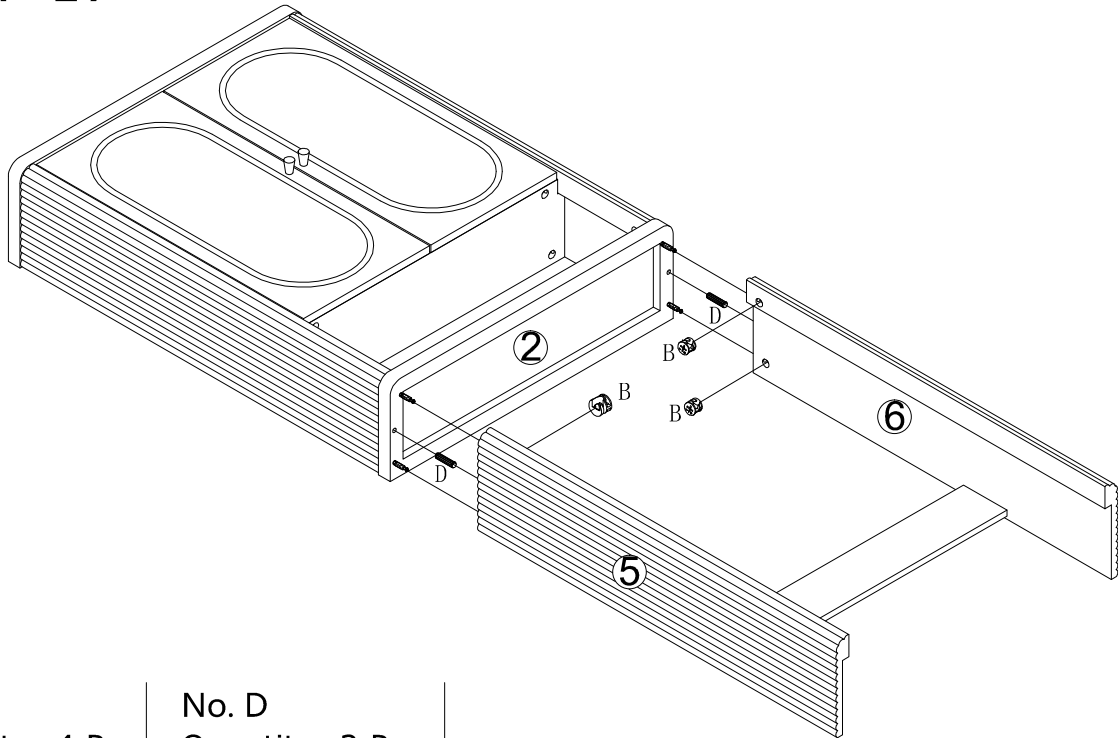

No. B  
Quantity: 4 Pcs  
Ø15



No. D  
Quantity: 2 Pcs  
8\*30mm

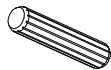

## STEP 18

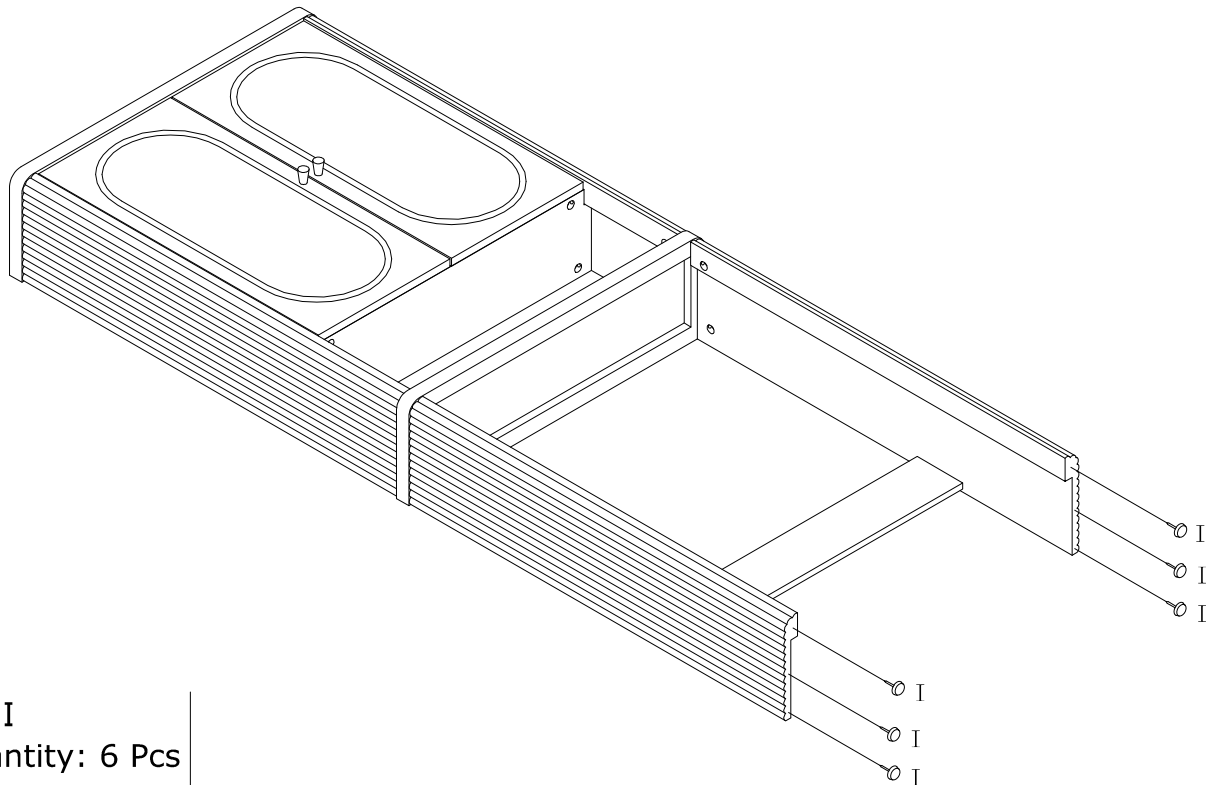

No. I  
Quantity: 6 Pcs  
Ø15



# STEP 19

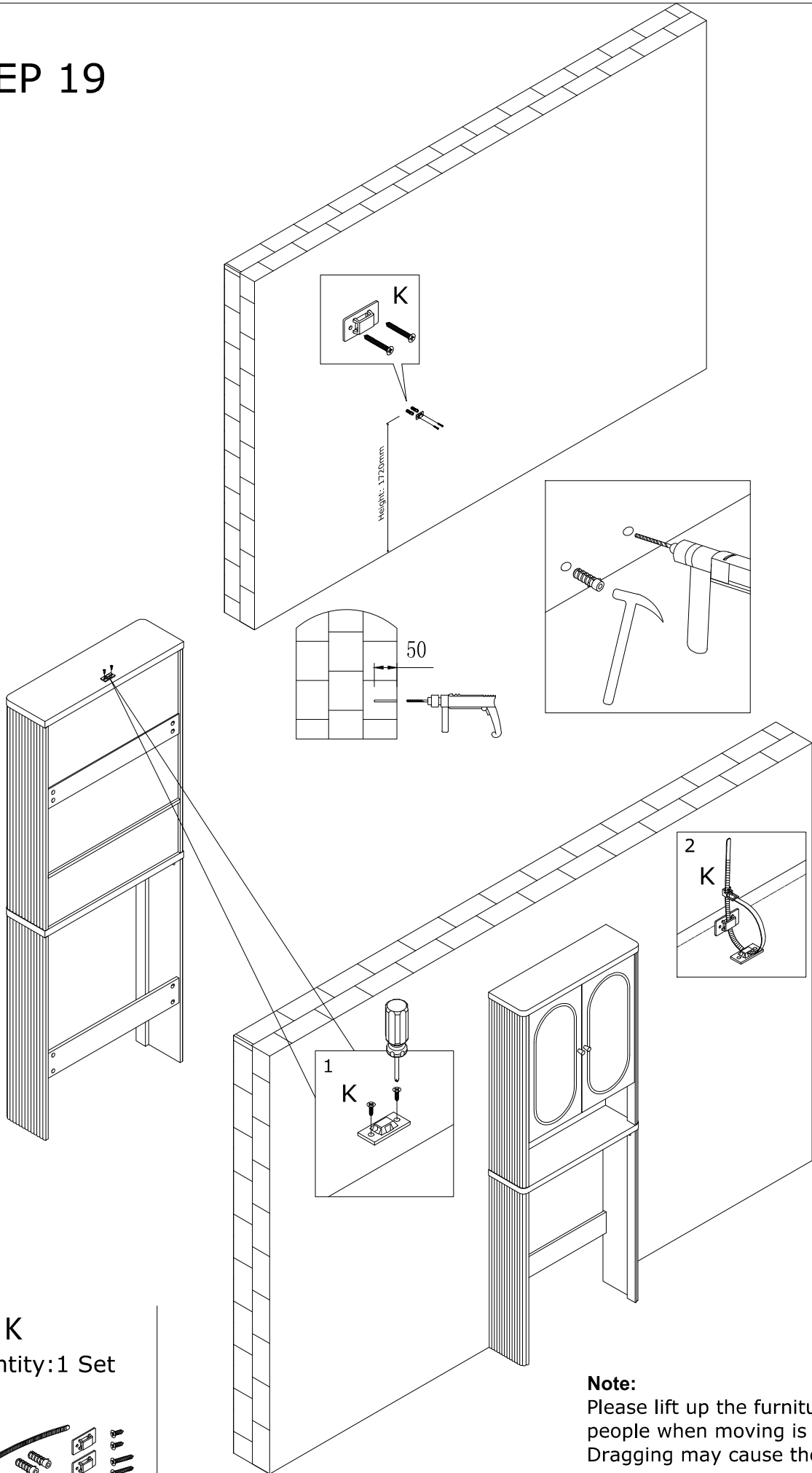

No. K  
Quantity: 1 Set

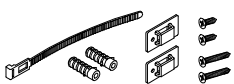

**Note:**  
Please lift up the furniture by two people when moving is needed.  
Dragging may cause the legs failure.