





## ASSEMBLY INSTRUCTION

### CHAIR

- IMPORTANT NOTE :**
- PLACE ALL WOODEN PART ON A CLEAN AND SMOOTH SURFACE SUCH AS RUG OR CARPET TO AVOID THE THE PART FROM BEING SCRATCHCH.
  - PLEASE FOLLOW THE ASSEMBLY INSTRUCTION STEP BY STEP.
  - DO NOT TIGHTEN ALL SCREW UNTIL THE CHAIR IS FULLY SET-UP.

#### Hardware List (USED FOR 3 CHAIRS)

| No | DESCRIPTION  | QTY.   |
|----|--|--------|
| A  | JCBC M6 x 50mm  | 18 pcs |
| B  | Spring Washer   | 18 pcs |
| C  | CSK M4 x 32mm   | 9 pcs  |
| D  | Wood Dowel      | 18 pcs |
| E  | Allen Key       | 1 pc   |

#### STEP 1

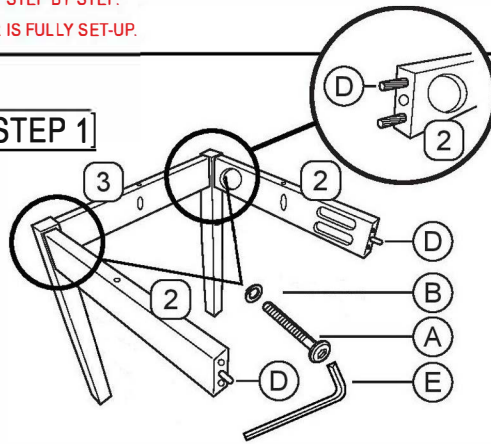

#### STEP 2

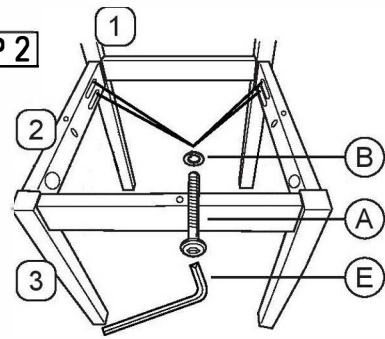

#### Part List

| No | DESCRIPTION           | QTY.  |
|----|-----------------------|-------|
| 1  | Bask Rest             | 3 pcs |
| 2  | Side Rail             | 6 pcs |
| 3  | Front Leg             | 3 pcs |
| 4  | Wooden Slat / Cushion | 3 pcs |

#### STEP 3

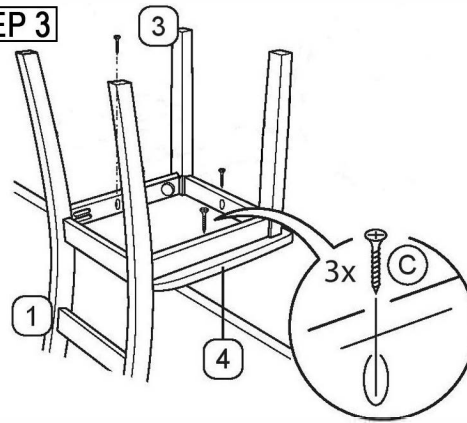

#### STEP 4

COMPLETED ASSEMBLE

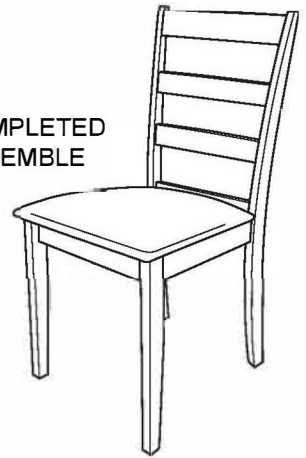





## ASSEMBLY INSTRUCTION

### CHAIR

- IMPORTANT NOTE :**
- PLACE ALL WOODEN PART ON A CLEAN AND SMOOTH SURFACE SUCH AS RUG OR CARPET TO AVOID THE THE PART FROM BEING SCRATCHCH.
  - PLEASE FOLLOW THE ASSEMBLY INSTRUCTION STEP BY STEP.
  - DO NOT TIGHTEN ALL SCREW UNTIL THE CHAIR IS FULLY SET-UP.

#### Hardware List (USED FOR 3 CHAIRS)

| No | DESCRIPTION  | QTY.   |
|----|--|--------|
| A  | JCBC M6 x 50mm  | 18 pcs |
| B  | Spring Washer   | 18 pcs |
| C  | CSK M4 x 32mm   | 9 pcs  |
| D  | Wood Dowel      | 18 pcs |
| E  | Allen Key       | 1 pc   |

#### STEP 1

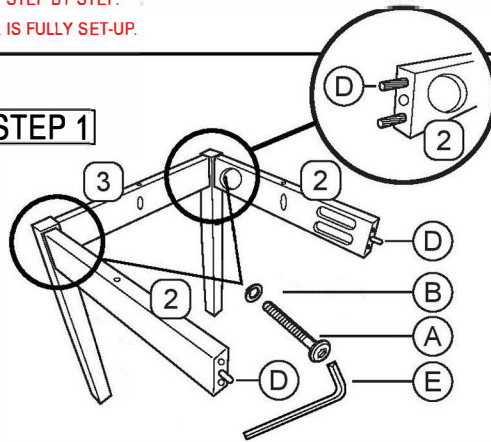

#### STEP 2

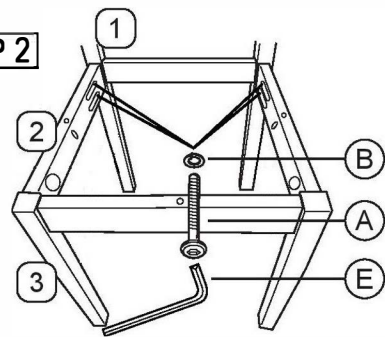

#### Part List

| No | DESCRIPTION           | QTY.  |
|----|-----------------------|-------|
| 1  | Bask Rest             | 3 pcs |
| 2  | Side Rail             | 6 pcs |
| 3  | Front Leg             | 3 pcs |
| 4  | Wooden Slat / Cushion | 3 pcs |

#### STEP 3

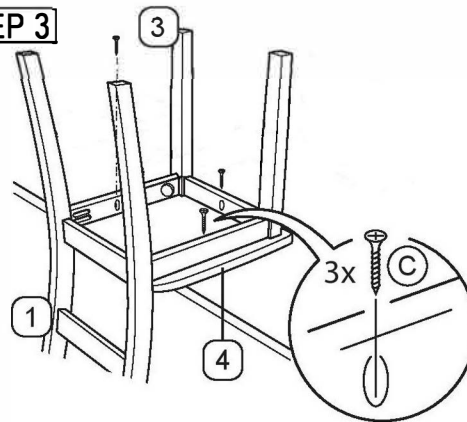

#### STEP 4

COMPLETED ASSEMBLE

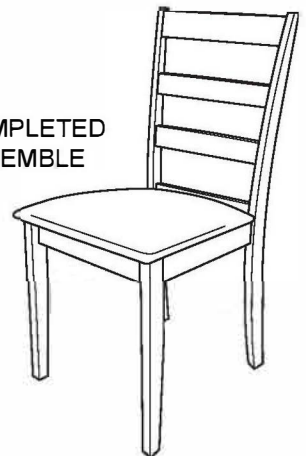





# BENCH

## ASSEMBLY INSTRUCTION

- IMPORTANT NOTE :** - PLACE ALL WOODEN PART ON A CLEAN AND SMOOTH SURFACE SUCH AS RUG OR CARPET TO AVOID THE PART FROM BEING SCRATCH.
- PLEASE FOLLOW THE ASSEMBLY INSTRUCTION STEP BY STEP.
- DO NOT TIGHTEN ALL SCREW UNTIL THE BENCH IS FULLY SET-UP

| No | PART LIST     | QTY.  |
|----|---------------|-------|
| A  | BENCH LEGS    | 4 pcs |
| B  | BENCH CUSHION | 1 pc  |

**\*\* SCREW DRIVER (NOT INCLUDED) \*\***

| No | HARDWARE LIST  | QTY.  |
|----|--|-------|
| 1  | JCBC M6 x 60mm  | 8 pcs |
| 2  | Spring Washer   | 8 pcs |
| 3  | Flat Washer     | 8 pcs |
| 4  | Allen Key M4    | 1 pc  |

STEP 1

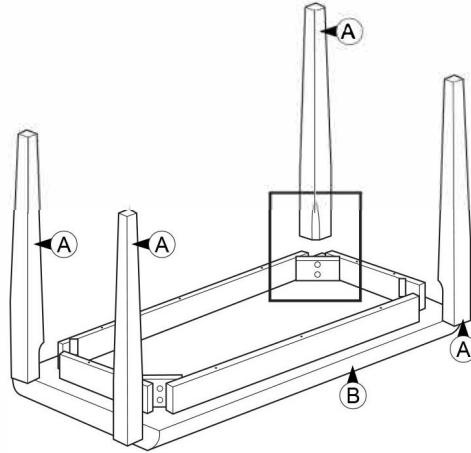
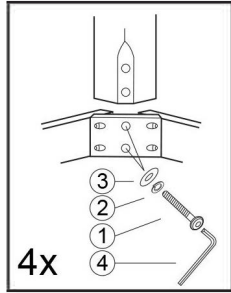

COMPLETED ASSEMBLY

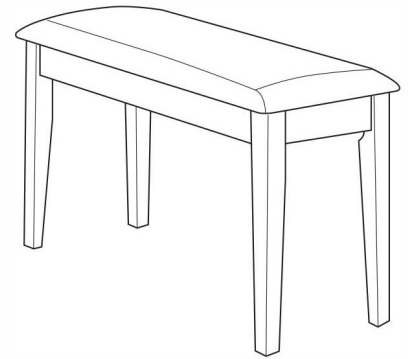





# BENCH

## ASSEMBLY INSTRUCTION

- IMPORTANT NOTE :** - PLACE ALL WOODEN PART ON A CLEAN AND SMOOTH SURFACE SUCH AS RUG OR CARPET TO AVOID THE PART FROM BEING SCRATCH.
- PLEASE FOLLOW THE ASSEMBLY INSTRUCTION STEP BY STEP.
- DO NOT TIGHTEN ALL SCREW UNTIL THE BENCH IS FULLY SET-UP

| No | PART LIST     | QTY.  |
|----|---------------|-------|
| A  | BENCH LEGS    | 4 pcs |
| B  | BENCH CUSHION | 1 pc  |

**\*\* SCREW DRIVER (NOT INCLUDED) \*\***

| No | HARDWARE LIST  | QTY.  |
|----|--|-------|
| 1  | JCBC M6 x 60mm  | 8 pcs |
| 2  | Spring Washer   | 8 pcs |
| 3  | Flat Washer     | 8 pcs |
| 4  | Allen Key M4    | 1 pc  |

STEP 1

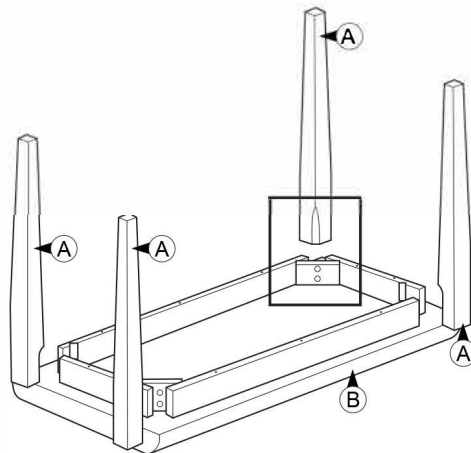
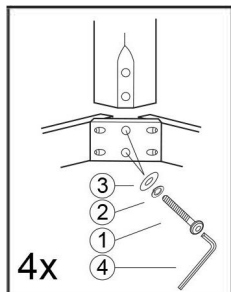

COMPLETED ASSEMBLY

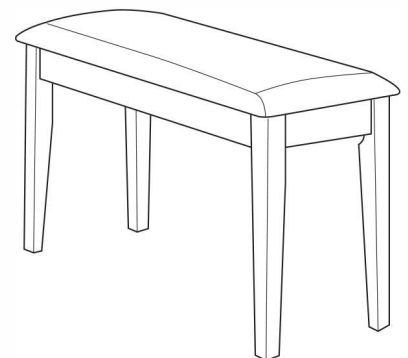





## ASSEMBLY INSTRUCTION

### TABLE

**IMPORTANT NOTE :**

- PLACE ALL WOODEN PART ON A CLEAN AND SMOOTH SURFACE SUCH AS RUG OR CARPET TO AVOID THE THE PART FROM BEING SCRATCHCH.
- PLEASE FOLLOW THE ASSEMBLY INSTRUCTION STEP BY STEP.
- DO NOT TIGHTEN ALL SCREW UNTIL THE CHAIR IS FULLY SET-UP

#### Hardware List

| No | DESCRIPTION  | QTY.  |
|----|--|-------|
| A  | JCBC M8 x 60mm  | 8 pcs |
| B  | Flat Washer     | 8 pcs |
| C  | Spring Washer   | 8 pcs |
| D  | Allen Key       | 1 pc  |

#### Part List

| No | DESCRIPTION | QTY.  |
|----|-------------|-------|
| 1  | Table Top   | 1 pc  |
| 2  | Table Leg   | 4 pcs |

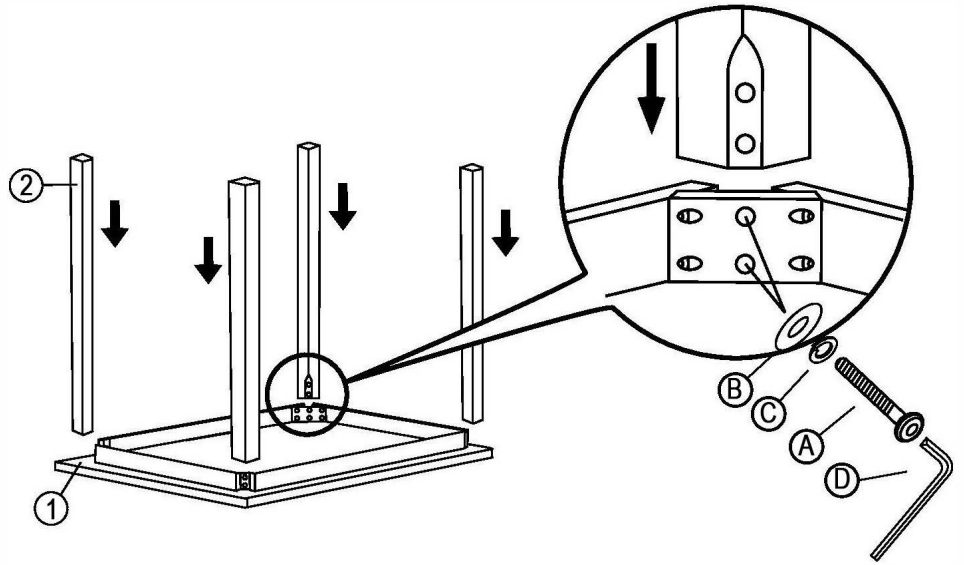
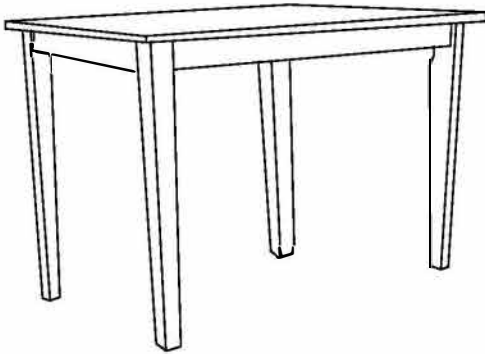





## ASSEMBLY INSTRUCTION

### TABLE

**IMPORTANT NOTE :**

- PLACE ALL WOODEN PART ON A CLEAN AND SMOOTH SURFACE SUCH AS RUG OR CARPET TO AVOID THE THE PART FROM BEING SCRATCHCH.
- PLEASE FOLLOW THE ASSEMBLY INSTRUCTION STEP BY STEP.
- DO NOT TIGHTEN ALL SCREW UNTIL THE CHAIR IS FULLY SET-UP

#### Hardware List

| No | DESCRIPTION  | QTY.  |
|----|--|-------|
| A  | JCBC M8 x 60mm  | 8 pcs |
| B  | Flat Washer     | 8 pcs |
| C  | Spring Washer   | 8 pcs |
| D  | Allen Key       | 1 pc  |

#### Part List

| No | DESCRIPTION | QTY.  |
|----|-------------|-------|
| 1  | Table Top   | 1 pc  |
| 2  | Table Leg   | 4 pcs |

