

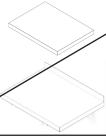

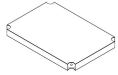

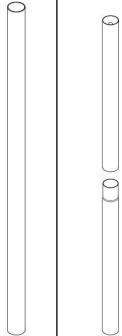



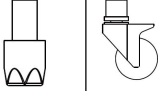

PACKING LIST

Note: Parts details 1 through 8 are available for all models.			
Item	Part Name	QTY	Picture
1	Panel	1 PCS	
2	Shelves	1 PCS	
3	<p style="text-align: center;">Table legs (whole / separated)</p> <p style="text-align: center;">Tip: legs various to refer the Product Parameters table</p>	<p>4 PCS</p> <p>(4PCS/4PCS)</p>	
4	Mounting sleeves	4 PCS	

5	<p>Support feet (3-inch universal wheels (2 with brakes))</p> <p>Tip: various to refer the Product Parameters table</p>	4 PCS	
6	M6 Allen socket screws	8PCS	
7	hex key	1PCS	
8	User Manual	1PCS	
Note: Parts details 9 through 13 are only available for HT-24 *24-3L			
9	M5 screws	12PCS	
10	φ5 gasket	12PCS	
11	flapper-1	1PCS	
12	flapper-2	1PCS	
13	flapper-3	1PCS	

ASSEMBLY STEP

This is the original instruction, please read all manual instructions carefully before operating. VEVOR reserves clear interpretation of our user manual. The appearance of the product shall be subject to the product you received. Please forgive us that we won't inform you again if there is any technology or software updates on our product.

1. Place the Top board mounting hole facing upwards, install the round pipe into the hole, fix it with M6 socket screws and have a torque greater than or equal to 25N.m

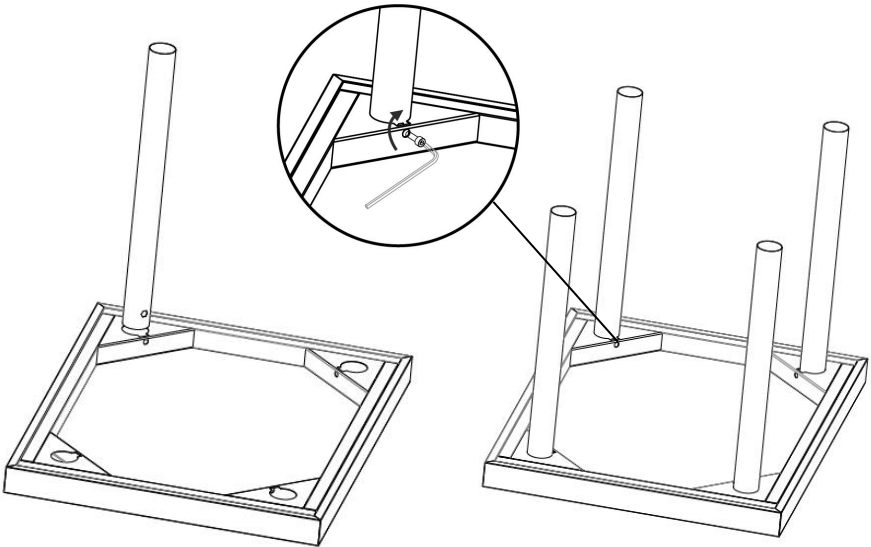

2. Some models distinguish the model of the upper and lower support pipes, and the upper and lower support pipes need to be covered

Note: This step can be omitted for products with whole legs;

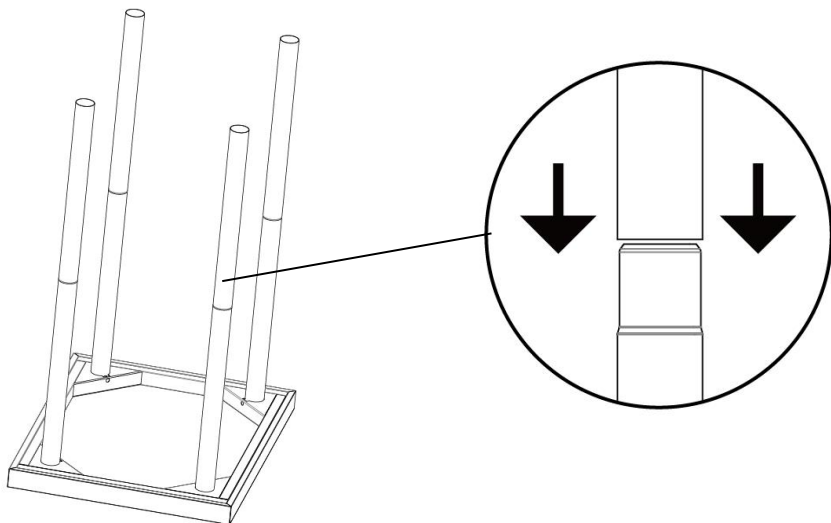

3. Install the partition according to the height of the hole position you need, fix the mounting hole with M6 socket socket screws and the torque is greater than or equal to 25N.m

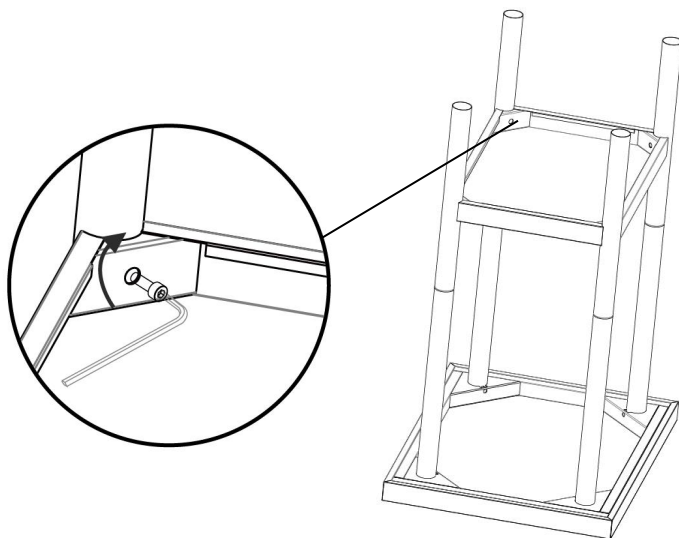

4. Install the casing knock into the round pipe.

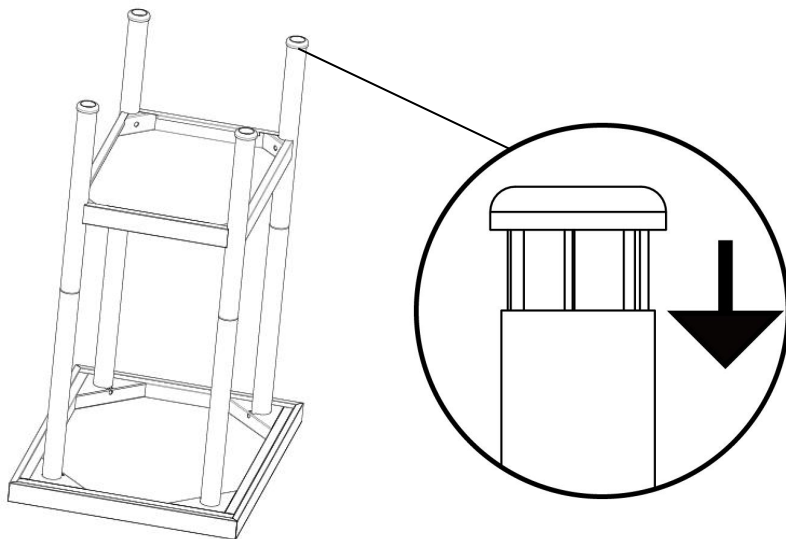

5. Install the support feet or wheels

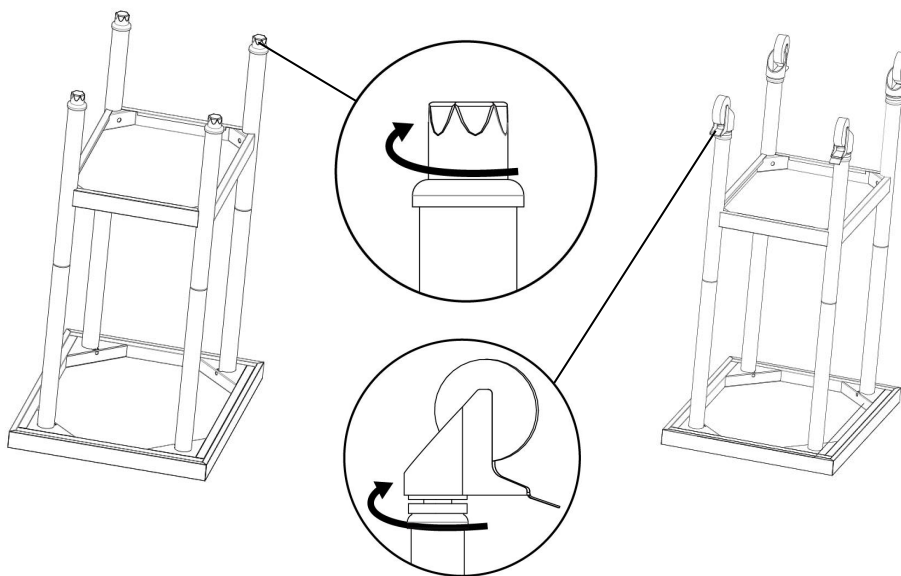

6. After completed the installation, turn the workbench over and adjust the height of the four support feet (or wheels) to ensure that the four feet are close to the ground and the workbench is stable

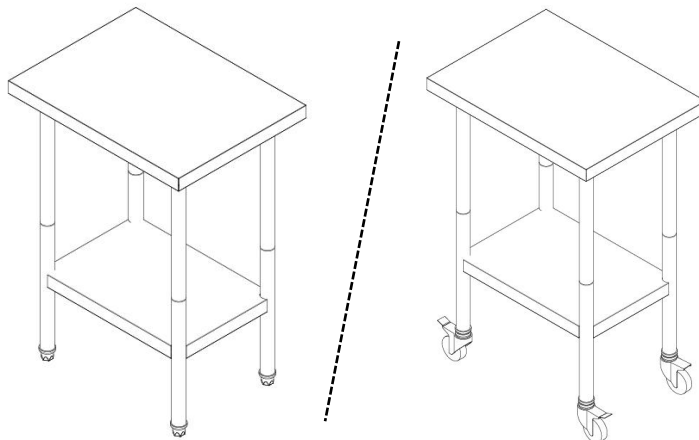

Note: If the workbench does not need to be moved. Please hold the brakes on the wheels to ensure that the table does not move.

The workbench has a maximum weight limit, please be careful not to exceed the maximum weight

Note: Below installation steps only for HET-24*24-3L

1. Install the flapper-1 on the workbench in the correct orientation (please refer to the logo direction), then tighten it with M5*12 screws and M5 flat pads, and fasten the baffle-1 on the workbench.

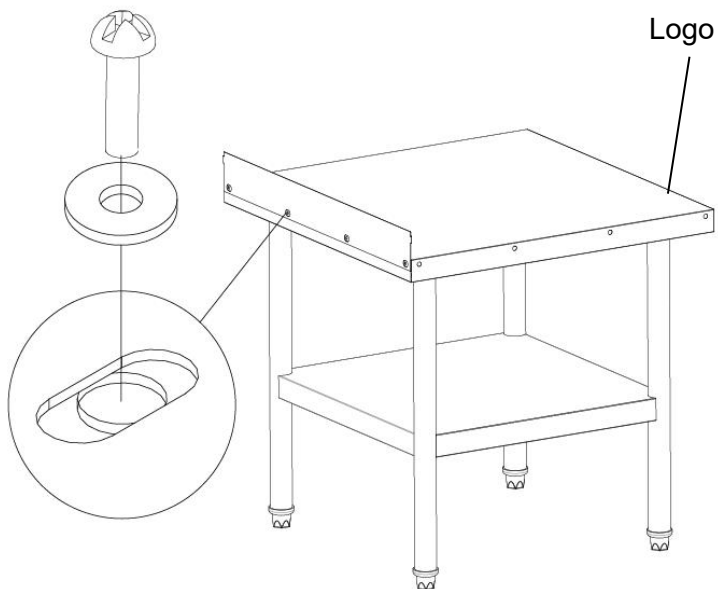

2.The baffle-2 and the baffle-1 are buckled and correctly placed on the workbench, and then fastened with M5*12 screws and M5 flat pads, and the baffle plate 1 is fastened on the workbench. (The installation steps of Bezel-3 are similar, please refer to this step)

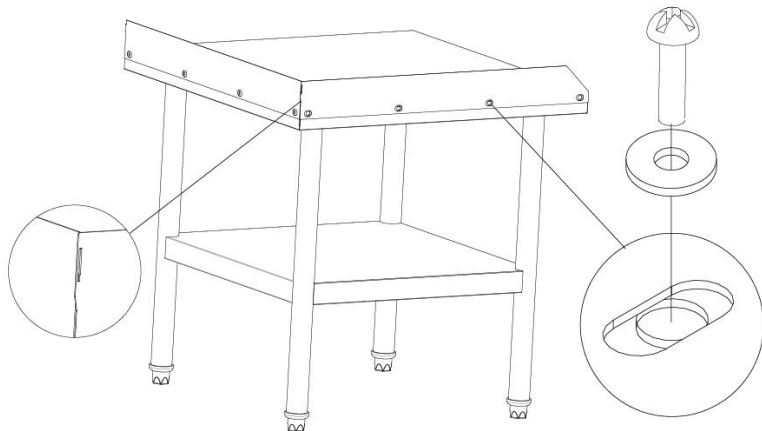

3. Finished product drawing HET-24*24-3L

