

TV Stand

Assembly Instructions - Please keep for future reference

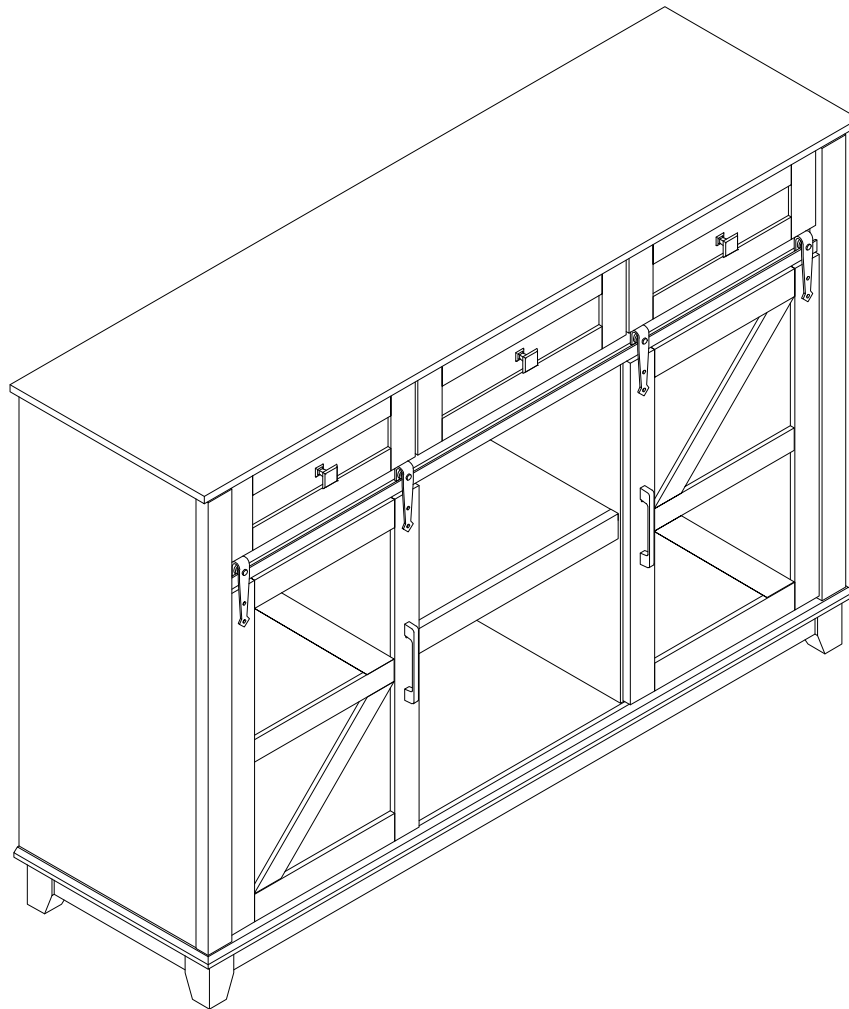

Dimensions

Width - 59 inch
Depth - 15.7 inch
Height - 34 inch

Important – Please read these instructions fully before starting assembly



Safety and Care Advice

Important – Please read these instructions fully before starting assembly

- Check you have all the components and tools listed on the following pages.
- Remove all fittings from the plastic bags and separate them into their groups.
- Keep children and animals away from the work area, small parts could choke if swallowed.
- Make sure you have enough space to layout the parts before starting.

- During assembly do not stand or put weight on the product, this could cause damage.
- Assemble the item as close (room) as possible.
- Assemble on a soft level surface to avoid damaging the unit or your floor.
- Parts of the assembly will be easier with 2 people.

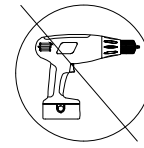

- To reduce the likelihood of damaging your product please ensure that your power drill is set on a low torque setting.

Care and maintenance

- Only clean using a damp cloth and mild detergent, do not use bleach or abrasive cleaners.
- From time to time check that there are no loose screws on this unit.
- This product should not be discarded with household waste. Take to your local authority waste disposal centre.

Handy Hints

- Assemble all parts and bolts loosely during assembly, only once the product is complete should you fully tighten the bolts
- Regularly check and ensure that all bolts and fittings are tightened properly.

WARNING In order to help prevent overturning – please follow these instructions

To help prevent product toppling over please follow the below steps:-

- Use the anti tip strap or wall fixing method provided (if applicable)
- Do not allow children to climb or hang on the furniture
- Do not open more than one drawer at a time
- Do not place heavy items in the top drawers
- Do not place heavy items on top of the furniture, unless the furniture has been designed for this purpose

You will need to provide wall plugs and screws applicable for your wall type

Components - Panels

Please check you have all the panels listed below

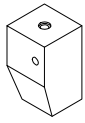

1 (85X50X50mm)X4

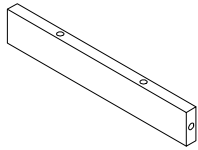

2 (283X45X14mm)X2

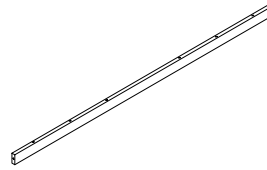

3 (1366X45X14mm)X2

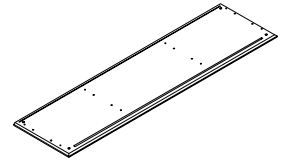

4 (1500X400X14mm)X1

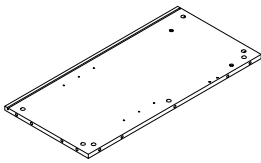

5 (736X358X12mm)X1

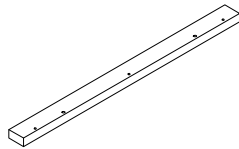

6 (736X50X24mm)X2

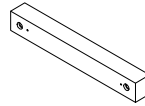

7 (300*40X34mm)X2

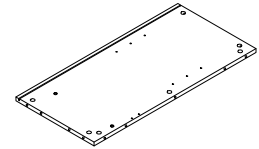

8 (736X358X12mm)X1

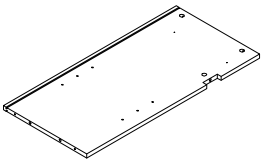

9 (736X356X14mm)X1

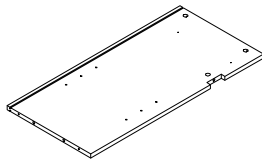

10 (736X356X14mm)X1

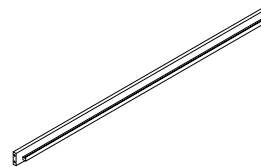

11 (1434X64X30mm)X1

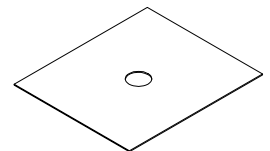

12 (431X372X2.5mm)X4

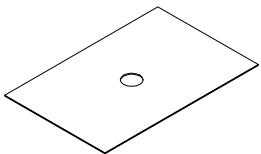

13 (568X372X2.5mm)X2

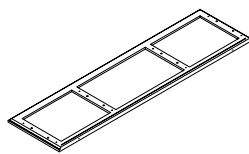

14 (1500X400X24mm)X1

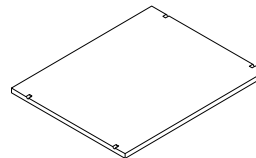

15 (418X334X12mm)X2

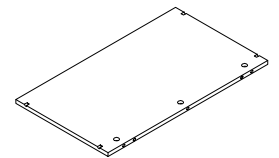

16 (555X320X12mm)X1

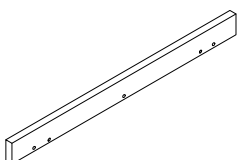

17 (555X45X14mm)X1

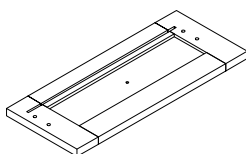

18 (400X163X14mm)X1

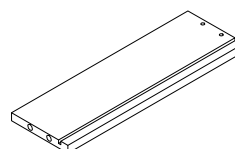

19 (300X102X12mm)X3

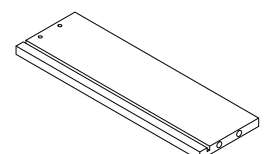

20 (300X102X12mm)X3

Components - Panels

Please check you have all the panels listed below

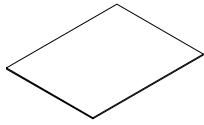

21 (347X295X2.5mm)X2

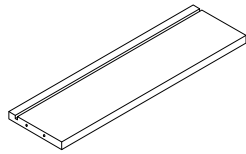

22 (339X102X12mm)X2

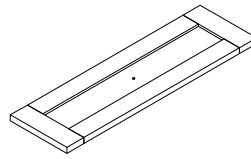

23 (554X163X14mm)X1

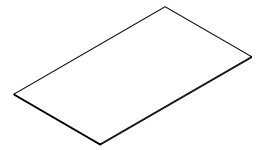

24 (518X295X2.5mm)X1

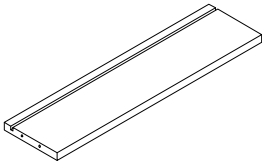

25 (510X102X12mm)X1

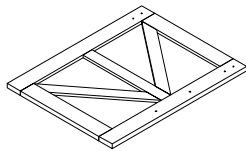

26 (507X400X14mm)X1

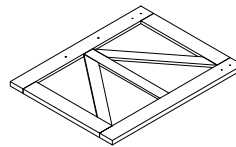

27 (507X400X14mm)X1

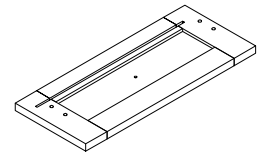













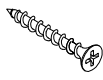



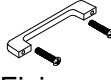

28 (400X163X14mm)X1

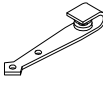
Components - Fittings

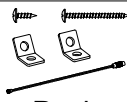
Please check you have all the fittings listed below

Note: The quantities below are the correct amount to complete the assembly. in some cases more fittings may be supplied than are required.

A  Cam Bolt x 59	B  Cam Lock x 59	C  Wooden Dowel x 26
D  Drawer slider 12" x 6	E  3.5*12mm Screw x 32	F  4*32mm Screw x 12
G  Handle & Fixings x 3	H  Back Panel Stiffener x 18	I  Protective Feet x 4
J  4*50mm Screw x 4	K  6x30mm Bolt x 8	L  Handle & Fixings x 2
M  Adjustable Foot x 2	N  Shelf Support Pin x 12	O  Pulley x 4
P  Plate x 4	Q  3.5*15mm Screw x 8	R  Wall Fixing Pack x 2
S  H bar 558mm x 1	T  H bar 421mm x 2	V  5*12mm Screw x 8

Tools required

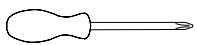

Phillips screwdriver
(medium & large)

Ruler - Use this ruler to help correctly identify the screws



The screws length is measured from the head to the point (30mm screw shown).

Using camlocks

Step 1

Connect the male camlock as directed in the assembly instructions using a screwdriver.

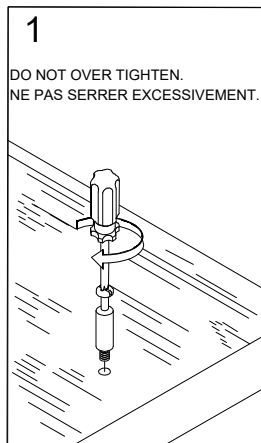

Step 2

Push the male camlock into the entry hole.

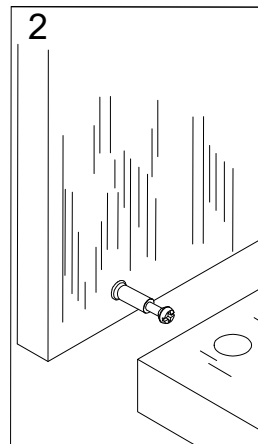

Step 3

Insert the female camlock as shown in the instructions.

Note: ensure that the arrow on the top of the camlock points towards the entry hole for the male camlock.

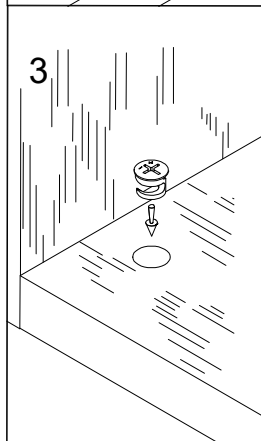

Step 4

Turn the female camlock clockwise with a screwdriver.

You should feel a click when the camlock is locked in place.

The joint is now secure.

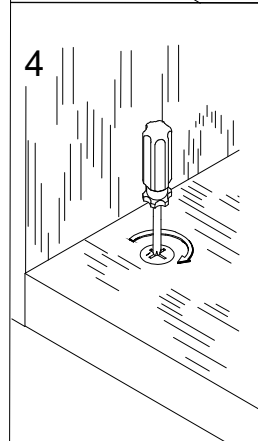

Assembly Instructions

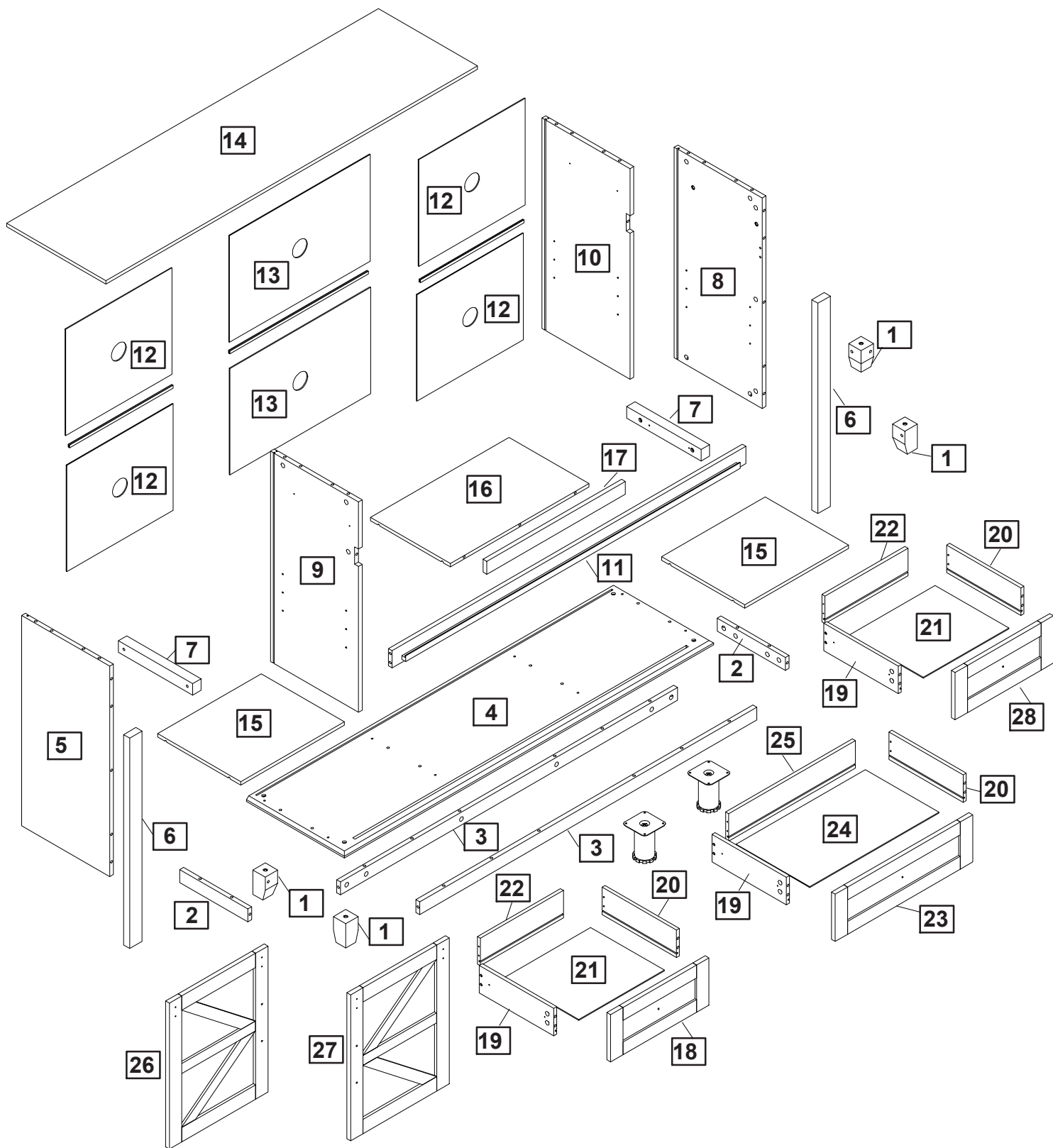

Assembly Instructions

Step 1

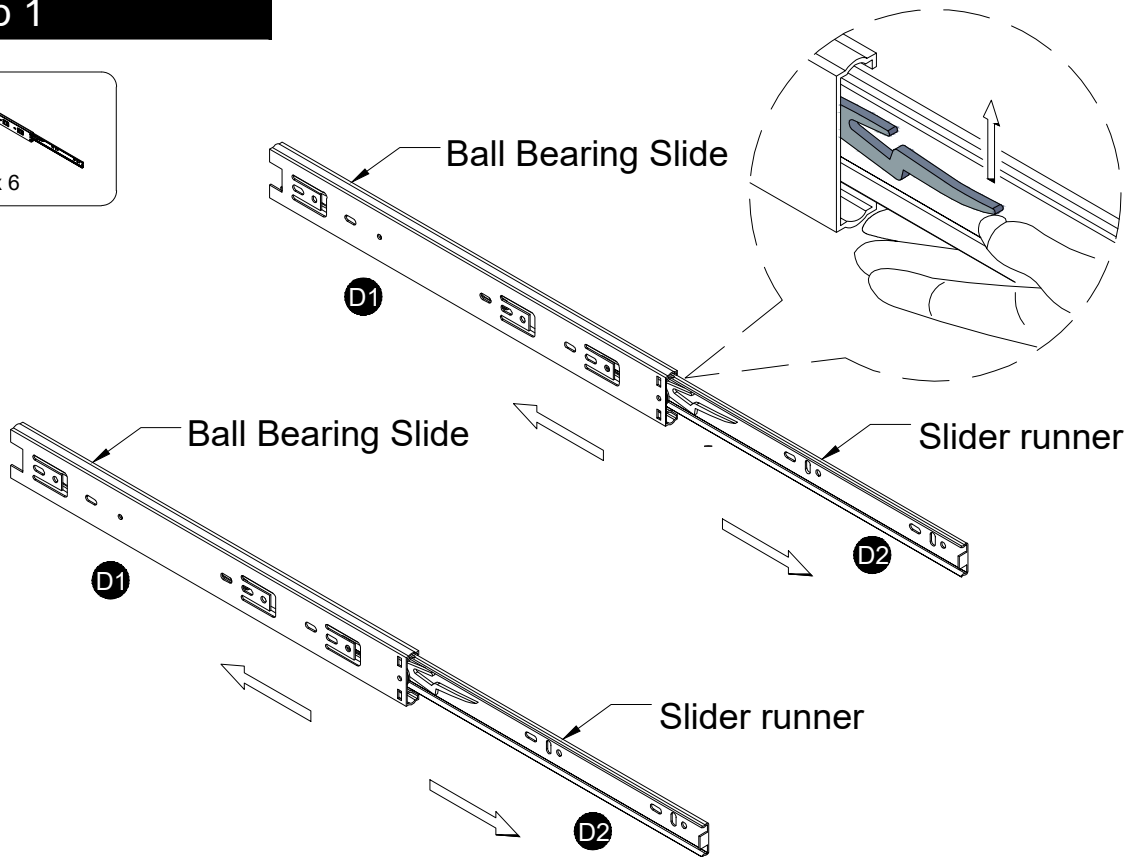
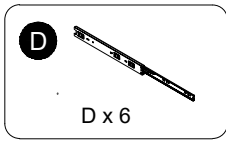

Step 2

CAM-LOCK

Tighten until shoulder is flush with panel. Do not overtighten or undertighten (see example below)

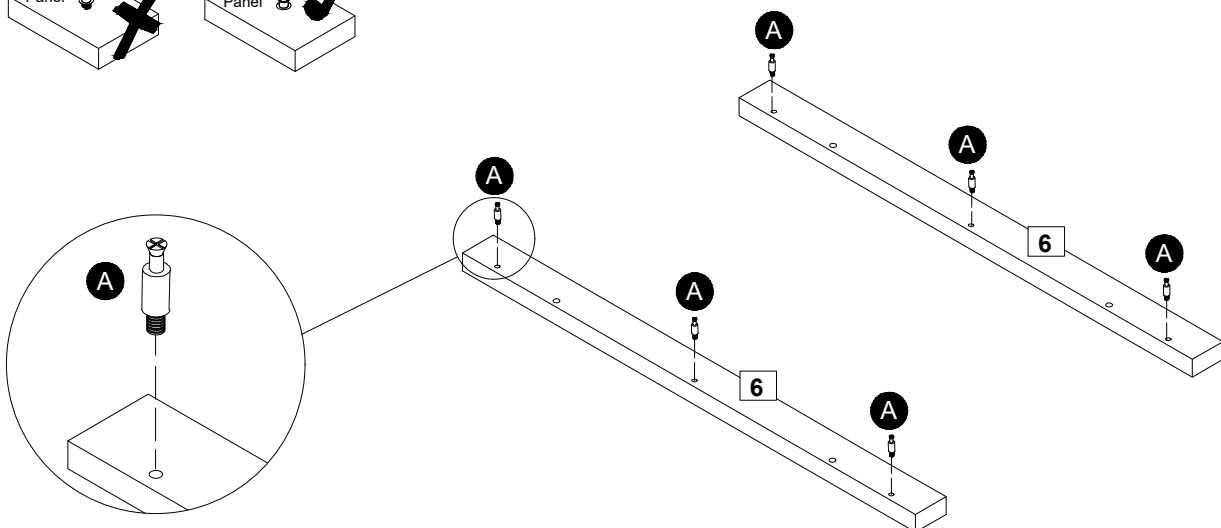
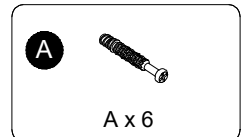
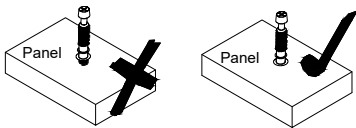
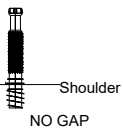

Attach cam bolt (A) to Parts (6) with a screwdriver.

Assembly Instructions

Step 3

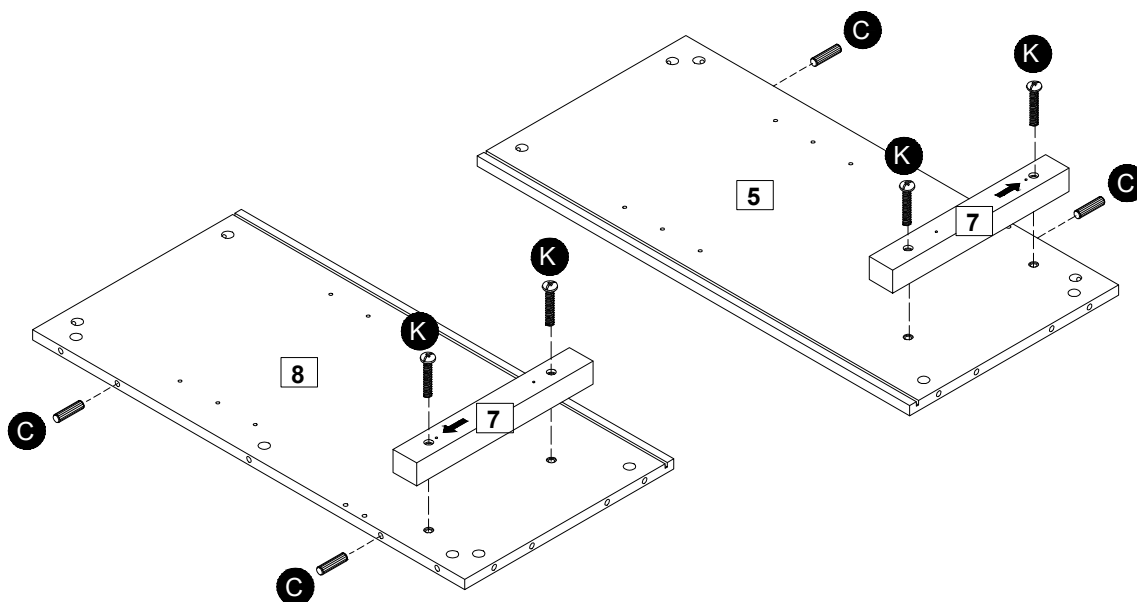
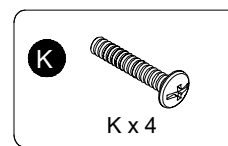
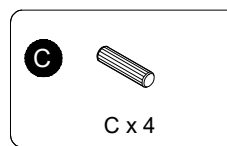

Attach Parts (7) to Parts (5, 8), using Bolt (K) with a screwdriver.
Insert wooden dowel (C) into Parts (5, 8).
Note: Pay attention to the direction of the arrow on the Parts (7).

Step 4

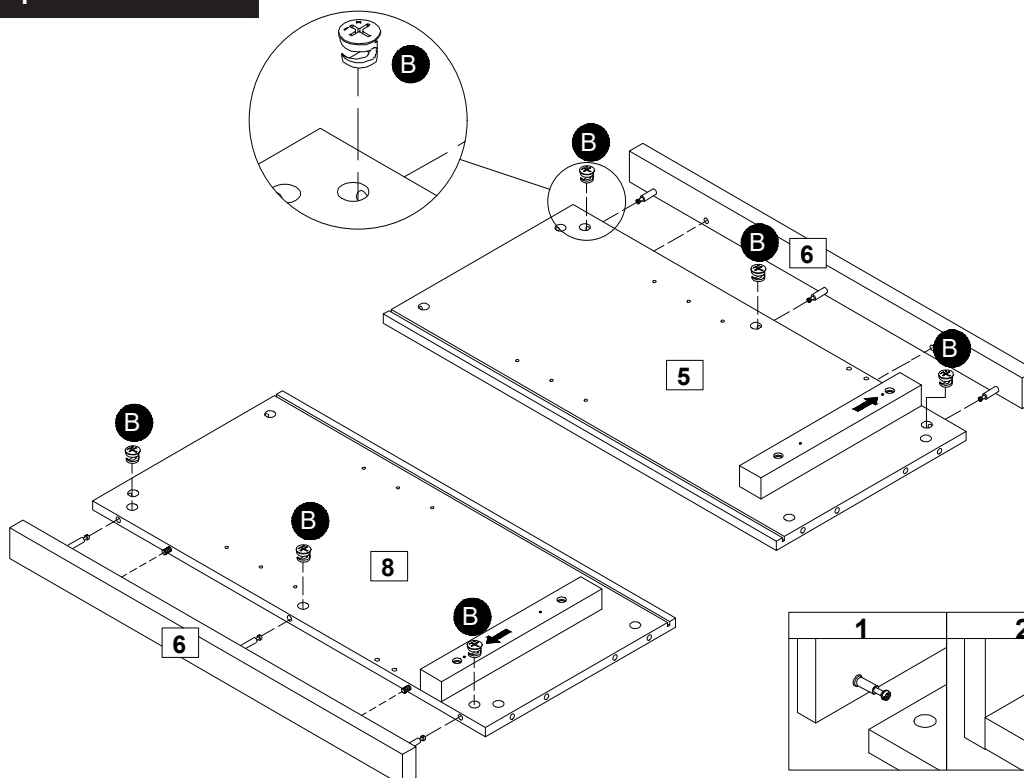

Attach Parts (6) to Parts (5, 8), then insert Female cam lock (B) and twist to secure.

Assembly Instructions

Step 5

CAM-LOCK

Tighten until shoulder is flush with panel. Do not overtighten or undertighten (see example below)

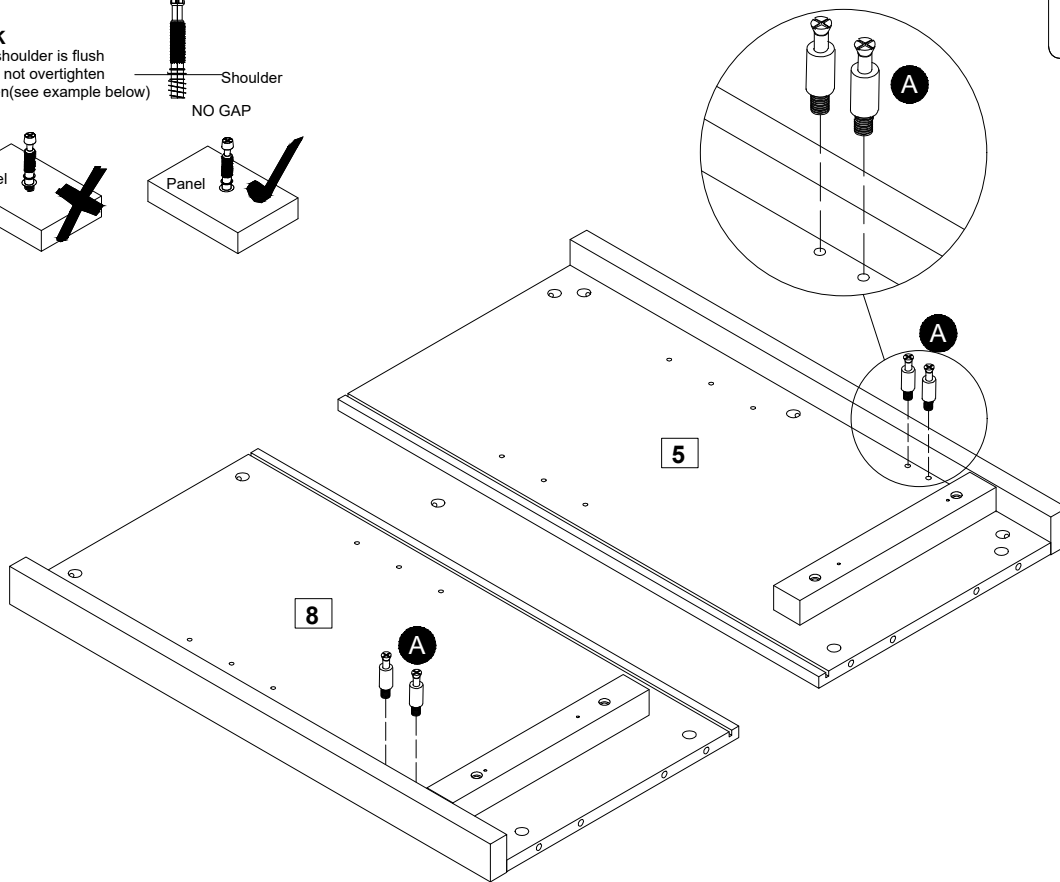
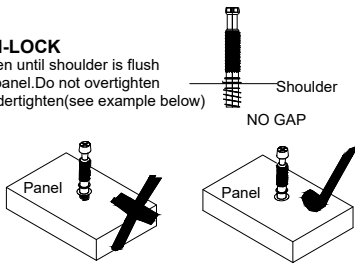

Attach cam bolt (A) to Parts (5, 8) with a screwdriver.

Step 6



E x 2



D1 x 1

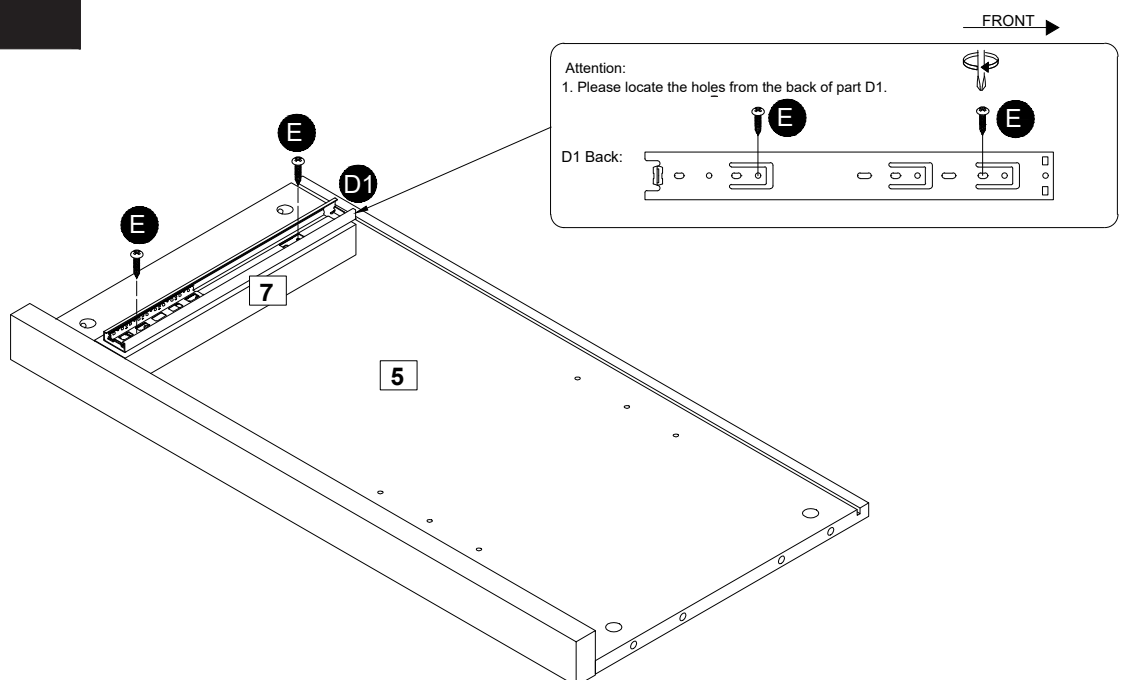

Attach Drawer slider (D1) to Part (7), align it with the pre-hole of Part (7), using Screw (E) with a screwdriver

Assembly Instructions

Step 7

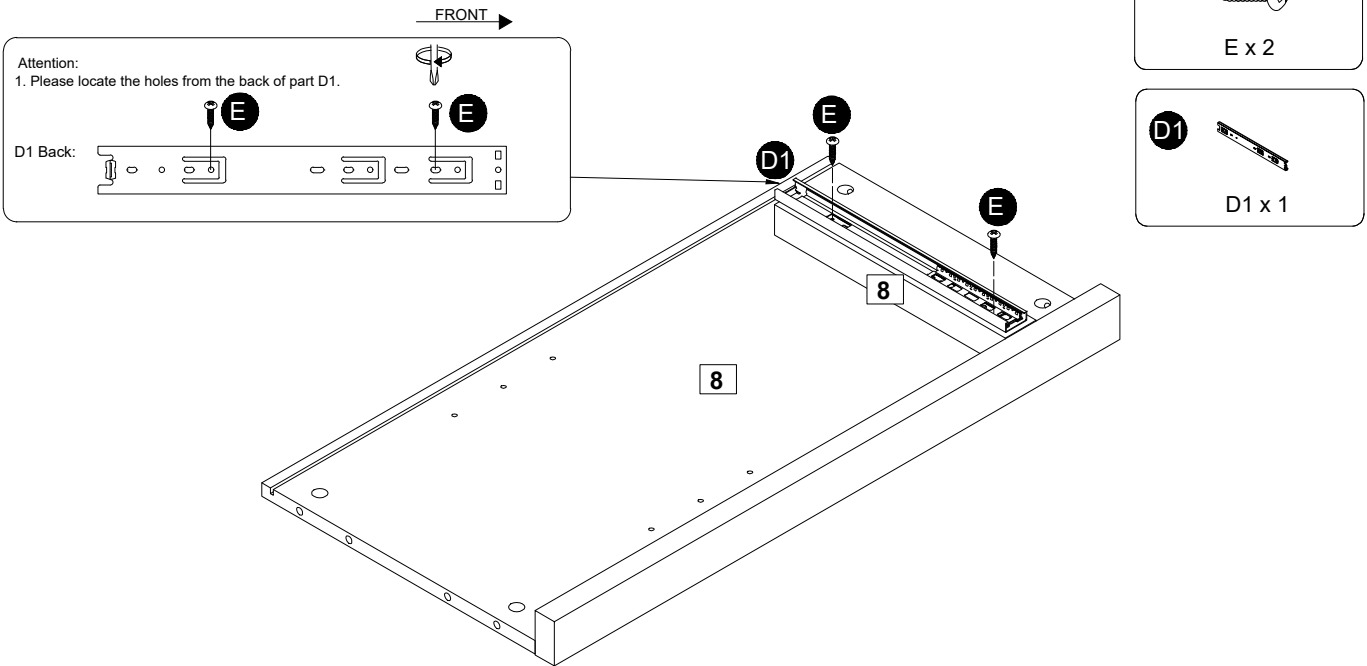

Attach Drawer slider (D1) to Part (7), align it with the pre-hole of Part (7), using Screw (E) with a screwdriver

Step 8

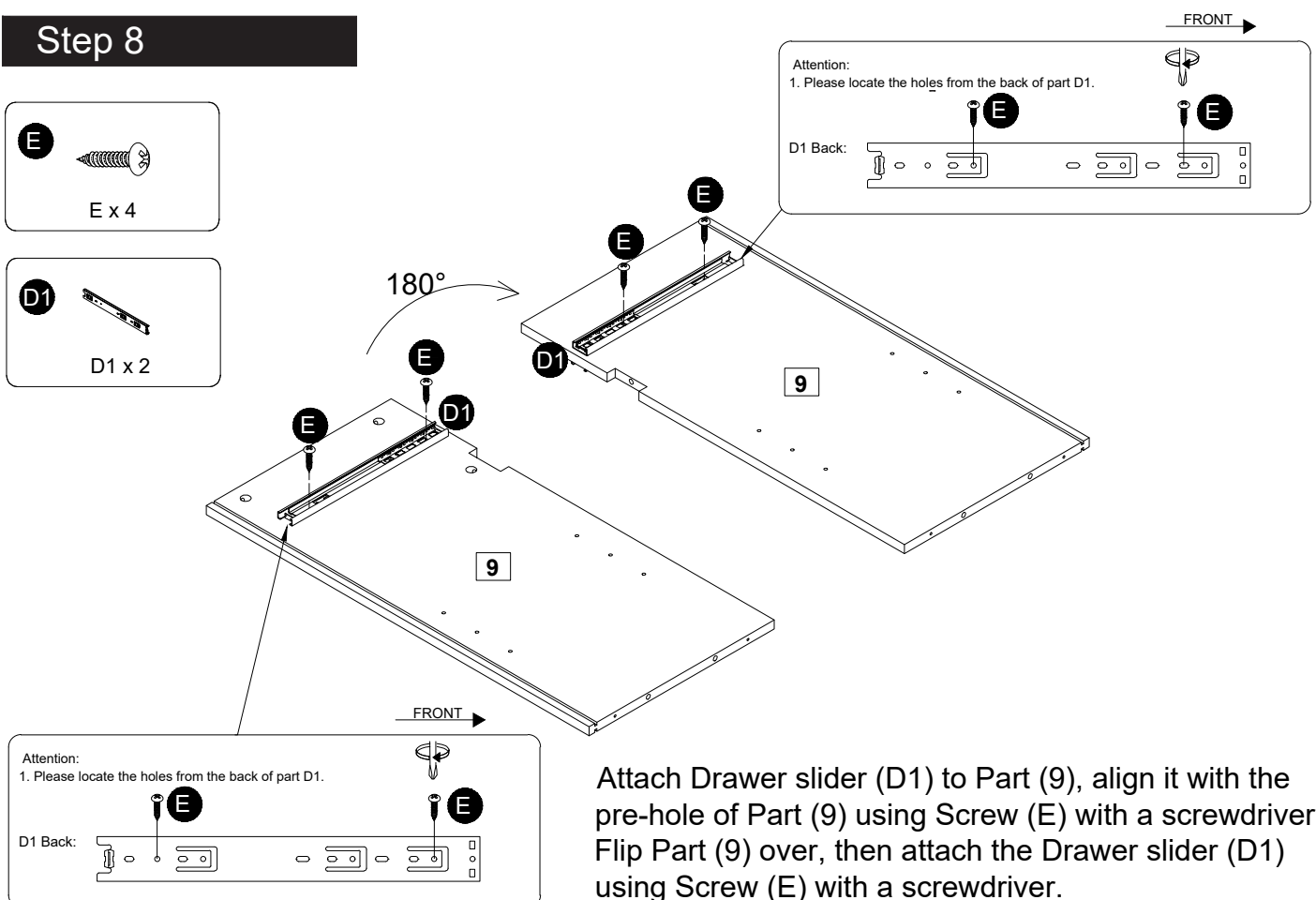

Attach Drawer slider (D1) to Part (9), align it with the pre-hole of Part (9) using Screw (E) with a screwdriver. Flip Part (9) over, then attach the Drawer slider (D1) using Screw (E) with a screwdriver.

Assembly Instructions

Step 9

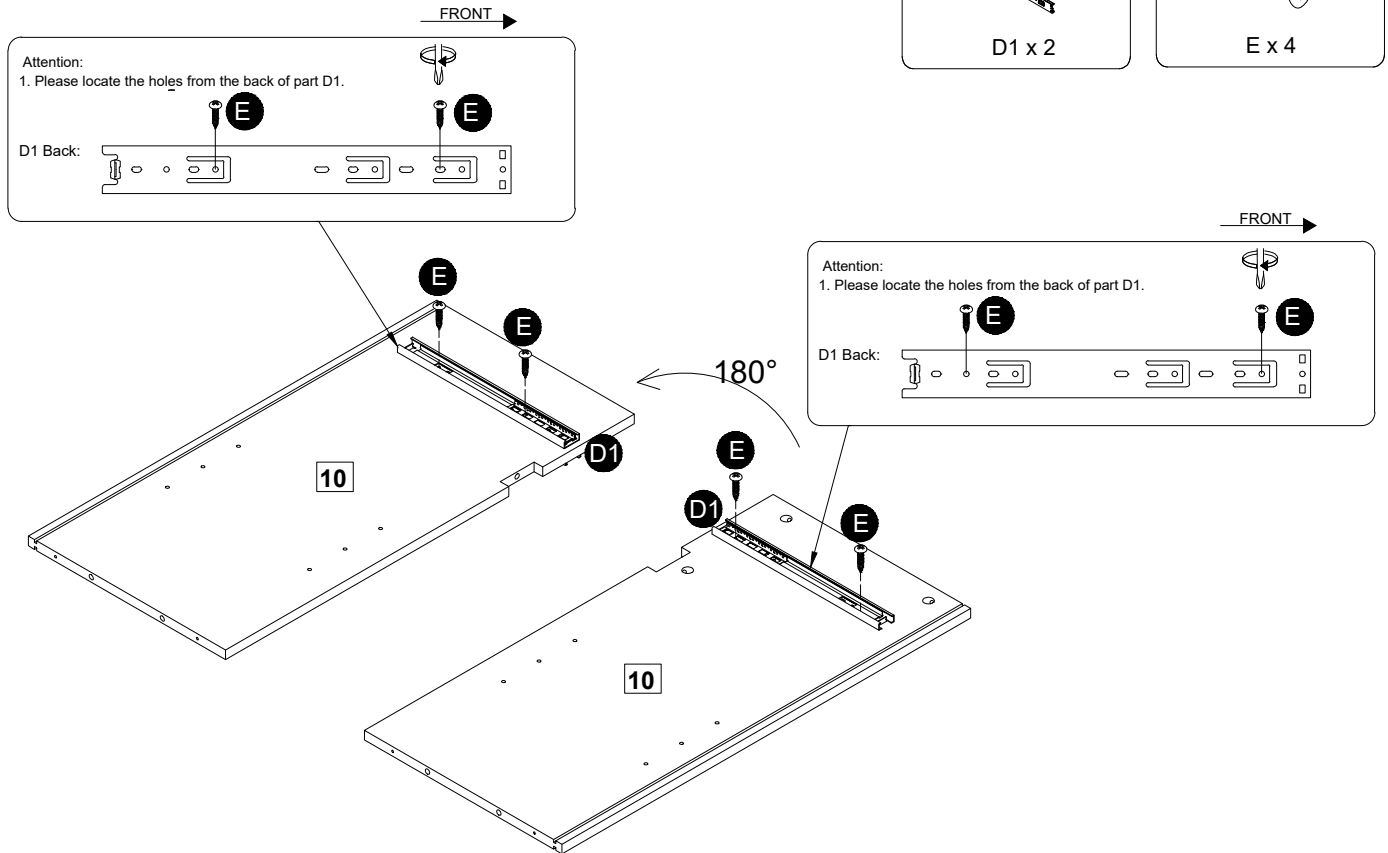

Attach Drawer slider (D1) to Part (10), align it with the pre-hole of Part (10) using Screw (E) with a screwdriver.

Flip Part (10) over, then attach the Drawer slider (D1) using Screw (E) with a screwdriver.

Step 10

CAM-LOCK

Tighten until shoulder is flush with panel. Do not overtighten or undertighten (see example below)

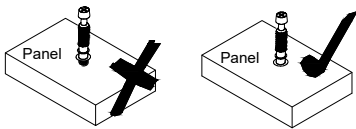
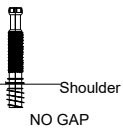

Step 10-1

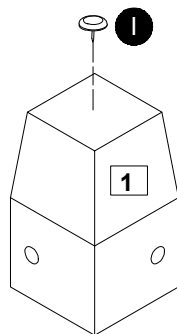

X4

Step 10-2

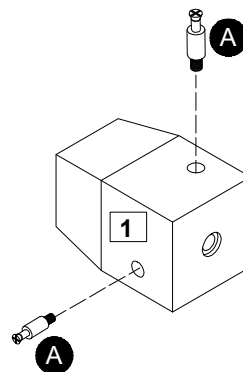

X4

Step 10-1: Insert protective feet (I)

Step 10-2: Attach Cam bolt (A) to Prts (1) with a screwdriver.

Assembly Instructions

Step 11

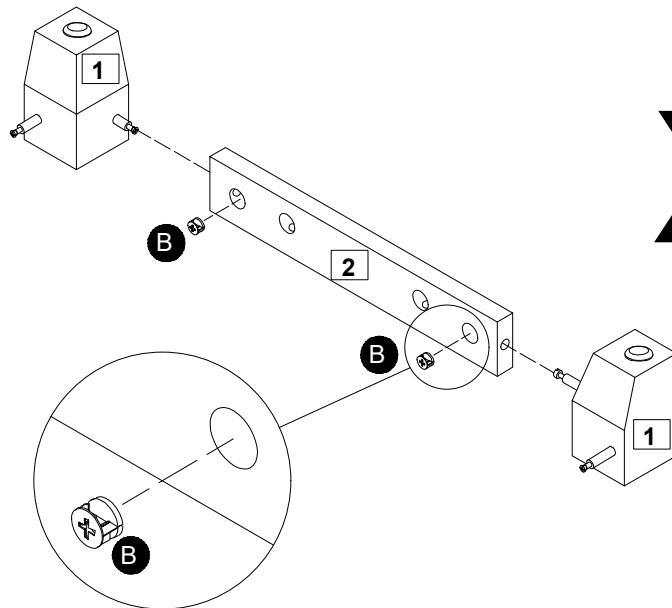

X2

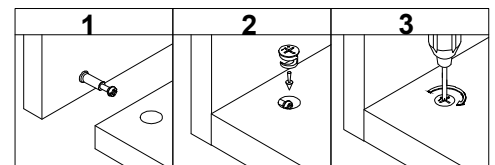

Attach Parts (1) to Part (2) then insert Female cam lock (B) and twist to secure.

Step 12

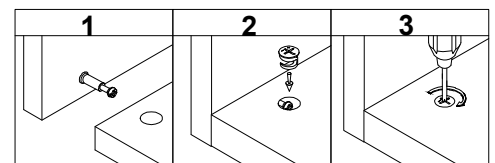
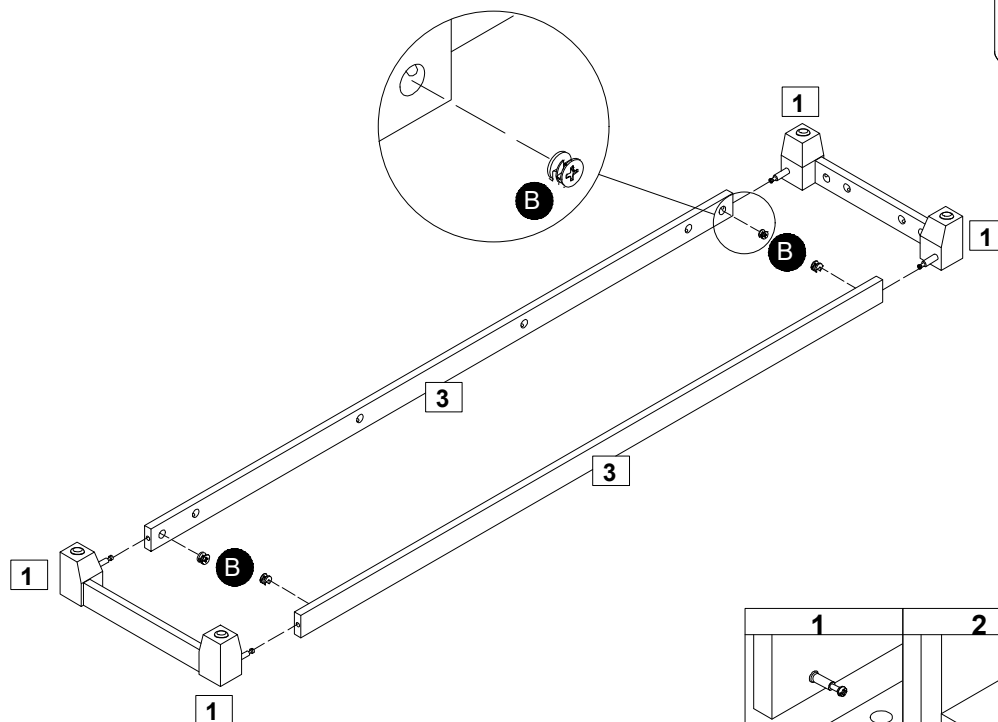

Attach Parts (1) to Parts (3), then insert Female cam lock (B) and twist to secure.

Assembly Instructions

Step 13

CAM-LOCK

Tighten until shoulder is flush with panel. Do not overtighten or undertighten (see example below)

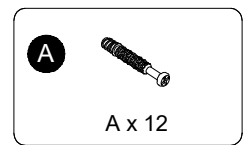
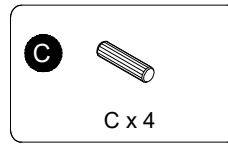
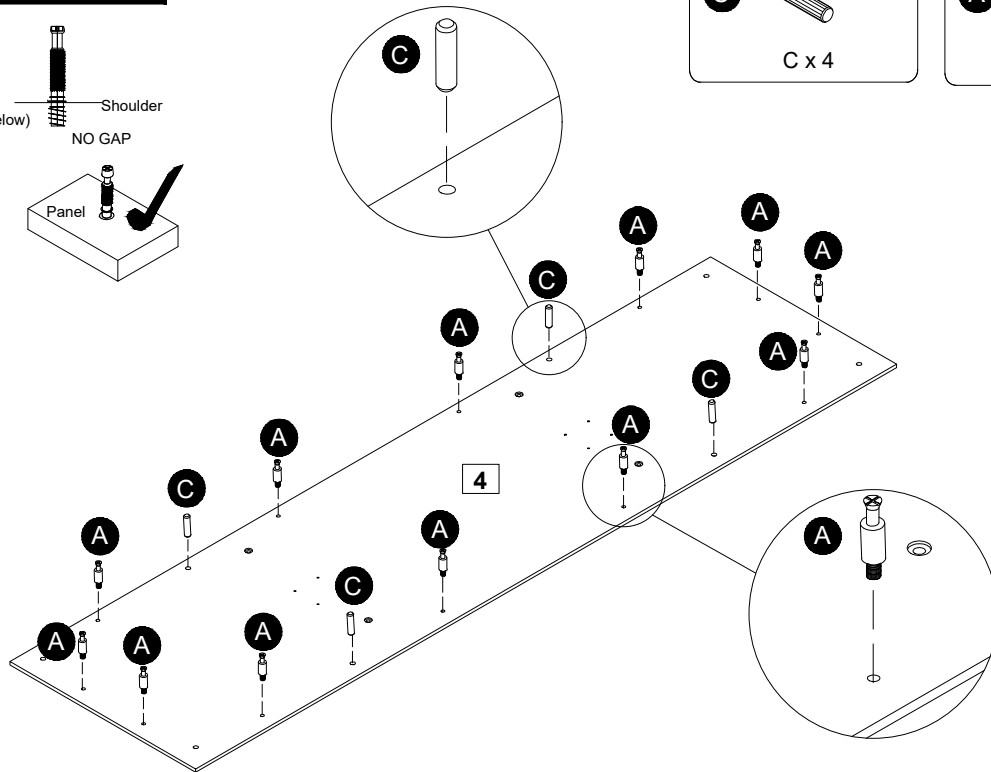
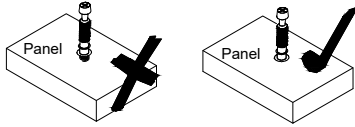
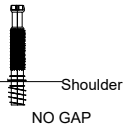

Attach Cam bolt (A) to Part (4) with a screwdriver.
Insert Wooden dowel (C) into Part (4).

Step 14

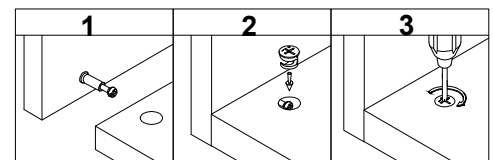
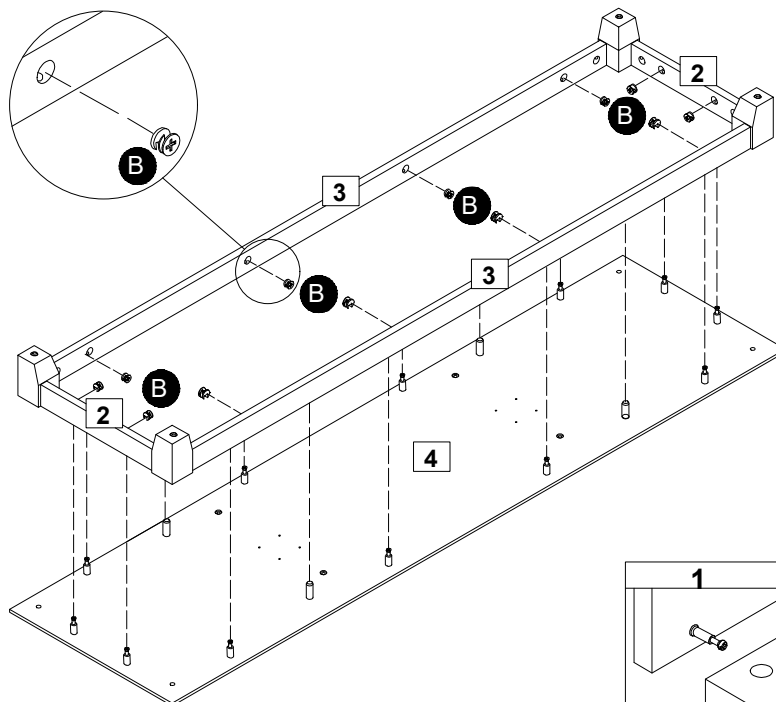

Attach Parts (2, 3) to Part (4), then insert Female cam lock (B) and twist to secure.

Assembly Instructions

Step 15

CAM-LOCK

Tighten until shoulder is flush with panel. Do not overtighten or undertighten (see example below)

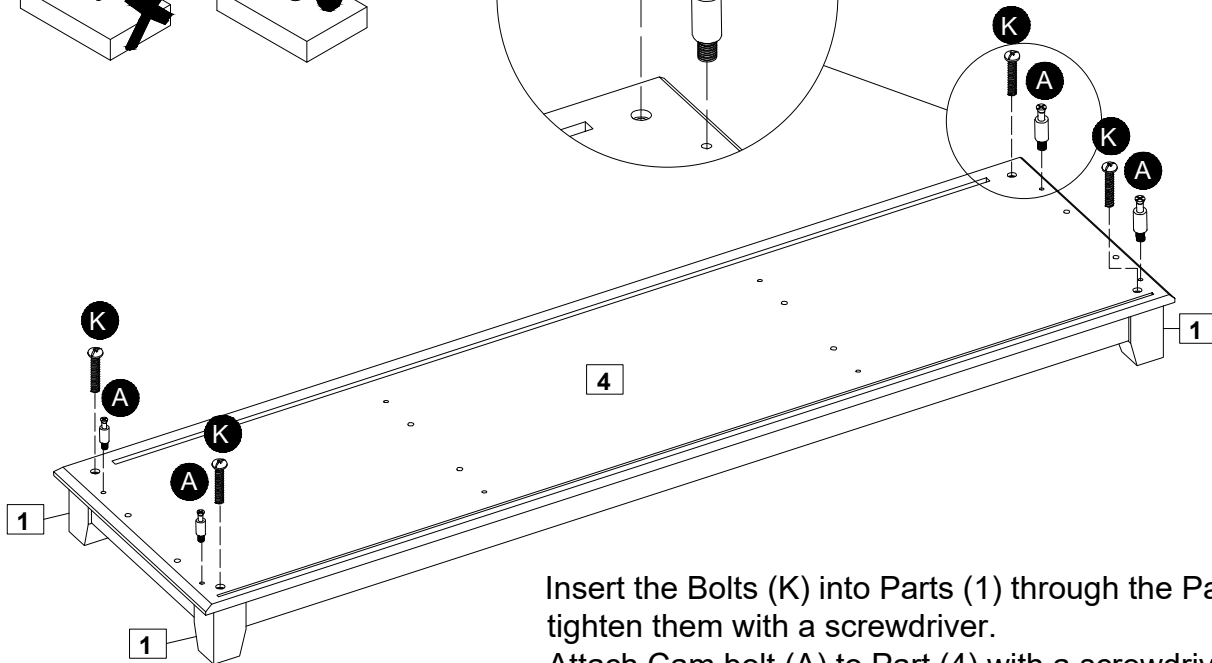
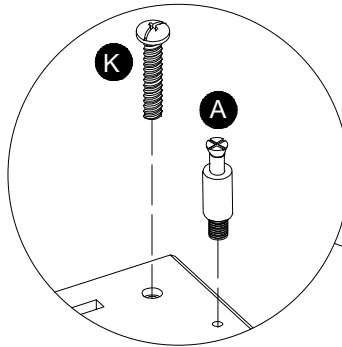
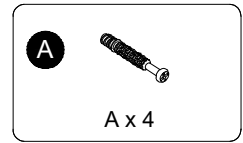
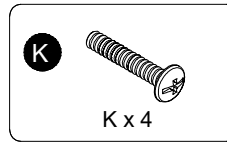
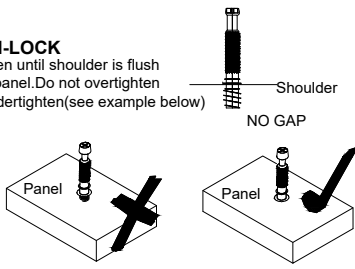

Insert the Bolts (K) into Parts (1) through the Part (4) tighten them with a screwdriver.
Attach Cam bolt (A) to Part (4) with a screwdriver.

Step 16

CAM-LOCK

Tighten until shoulder is flush with panel. Do not overtighten or undertighten (see example below)

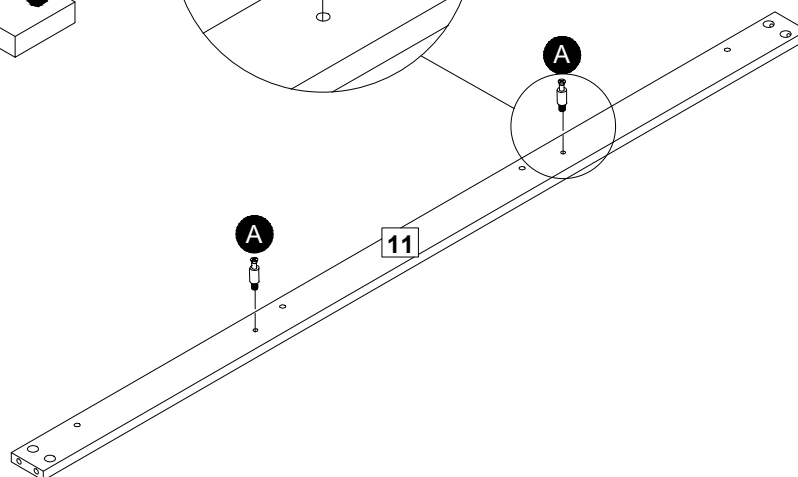
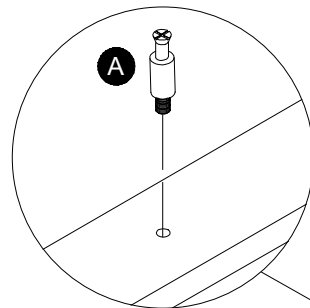
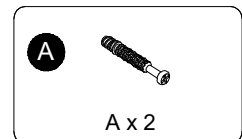
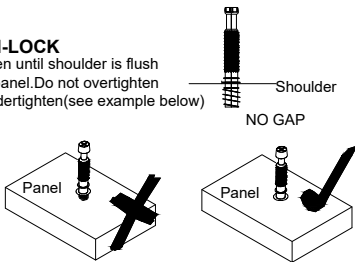

Attach Cam bolt (A) to Part (11) with a screwdriver.

Assembly Instructions

Step 17

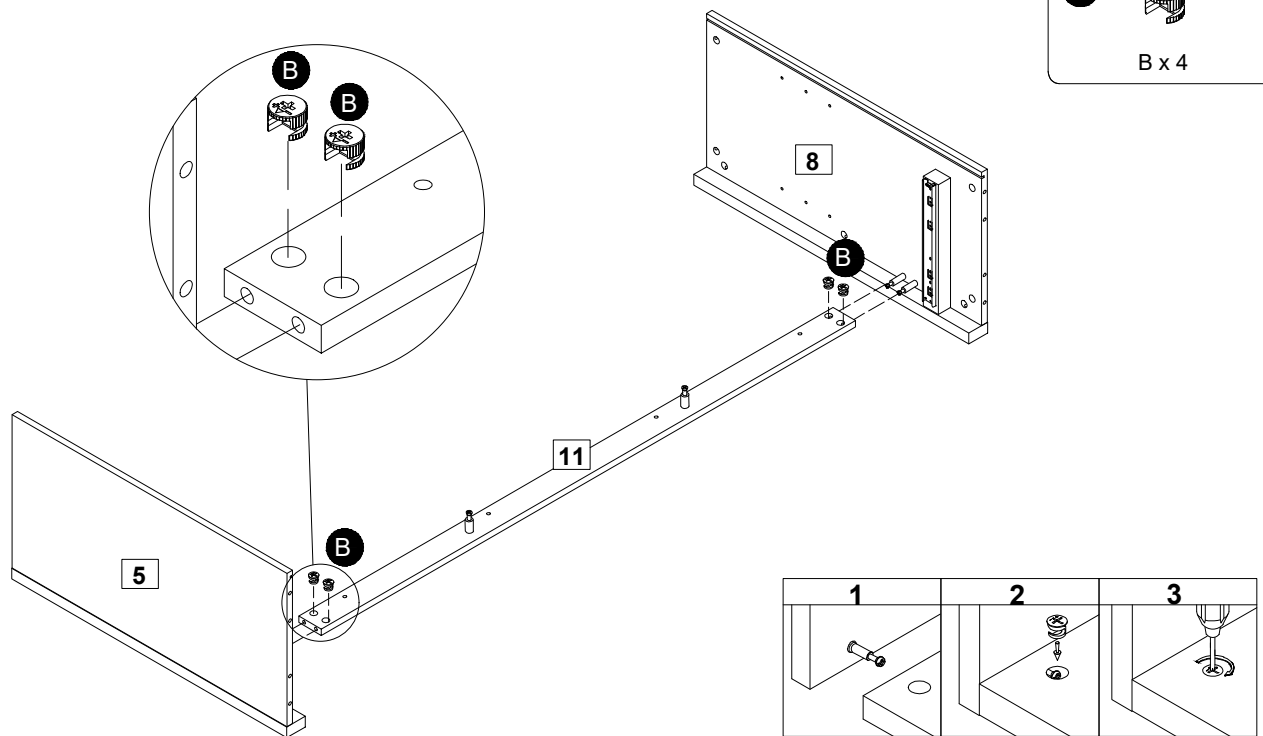

Attach Parts (5, 8) to Part (11), then insert Female cam lock (B) and twist to secure.

Step 18

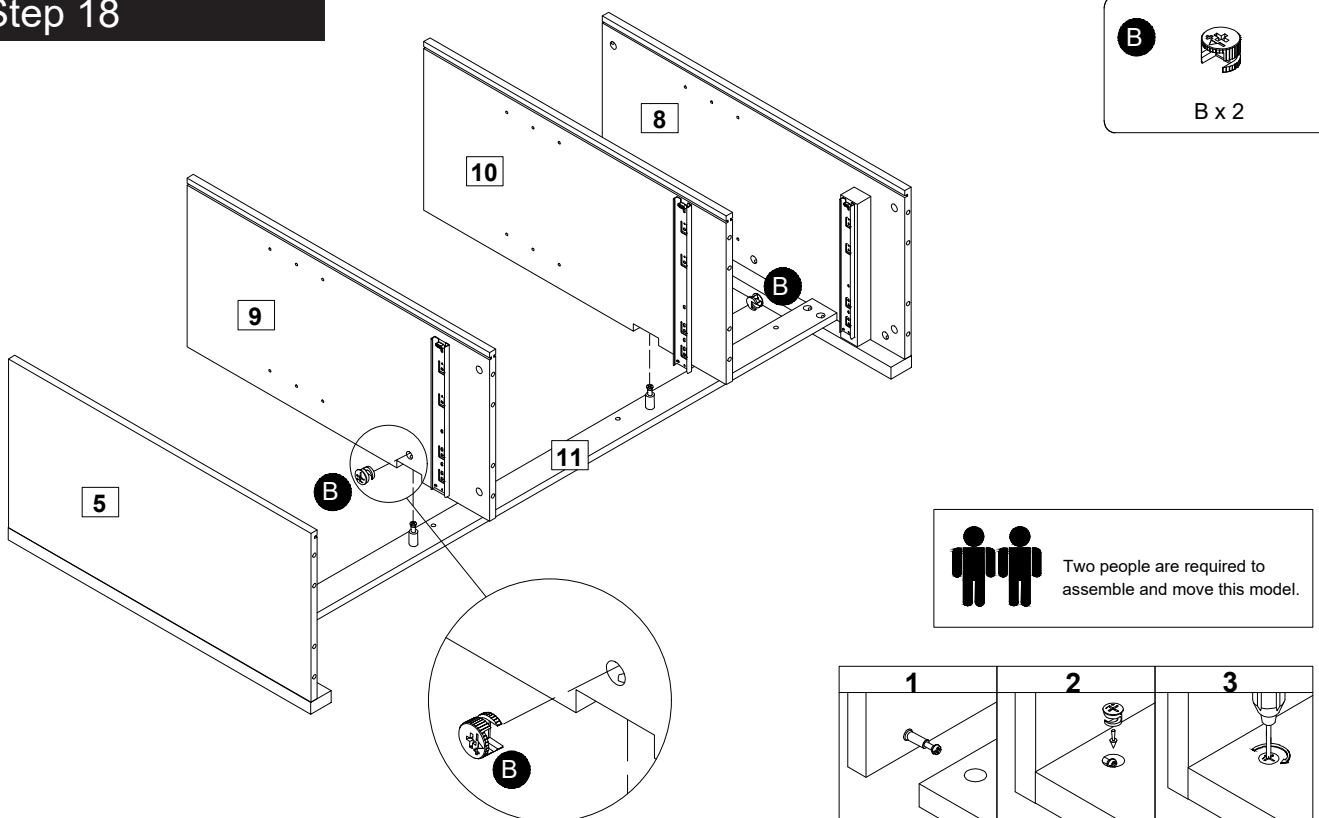

Attach Parts (9, 10) to Part (11), then insert Female cam lock (B) and twist to secure.

Assembly Instructions

Step 19

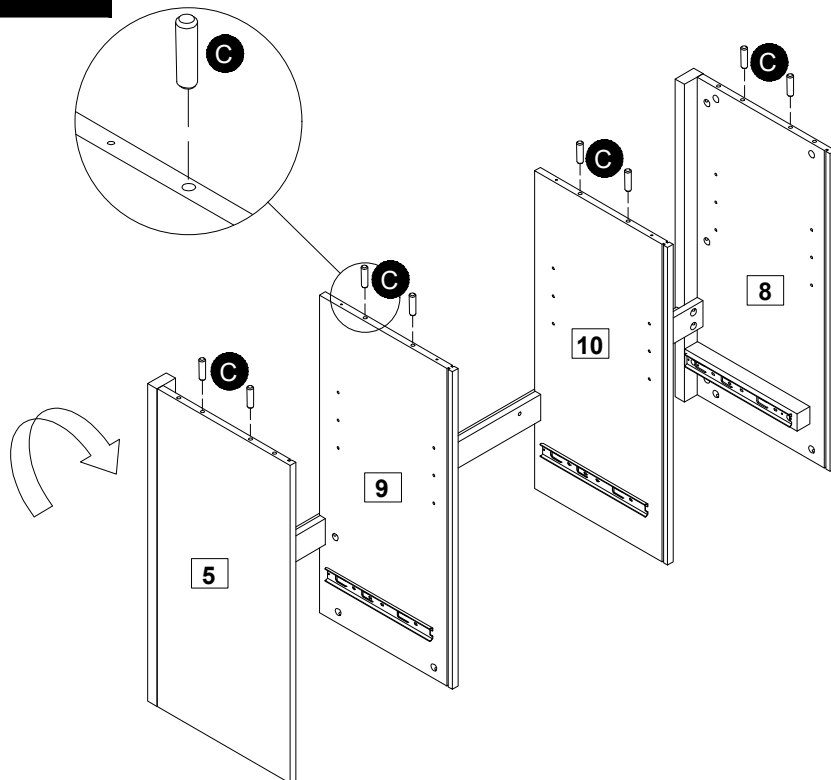

Flip over then insert Wooden dowel (C) into Part (5, 8, 9, 10).

Step 20

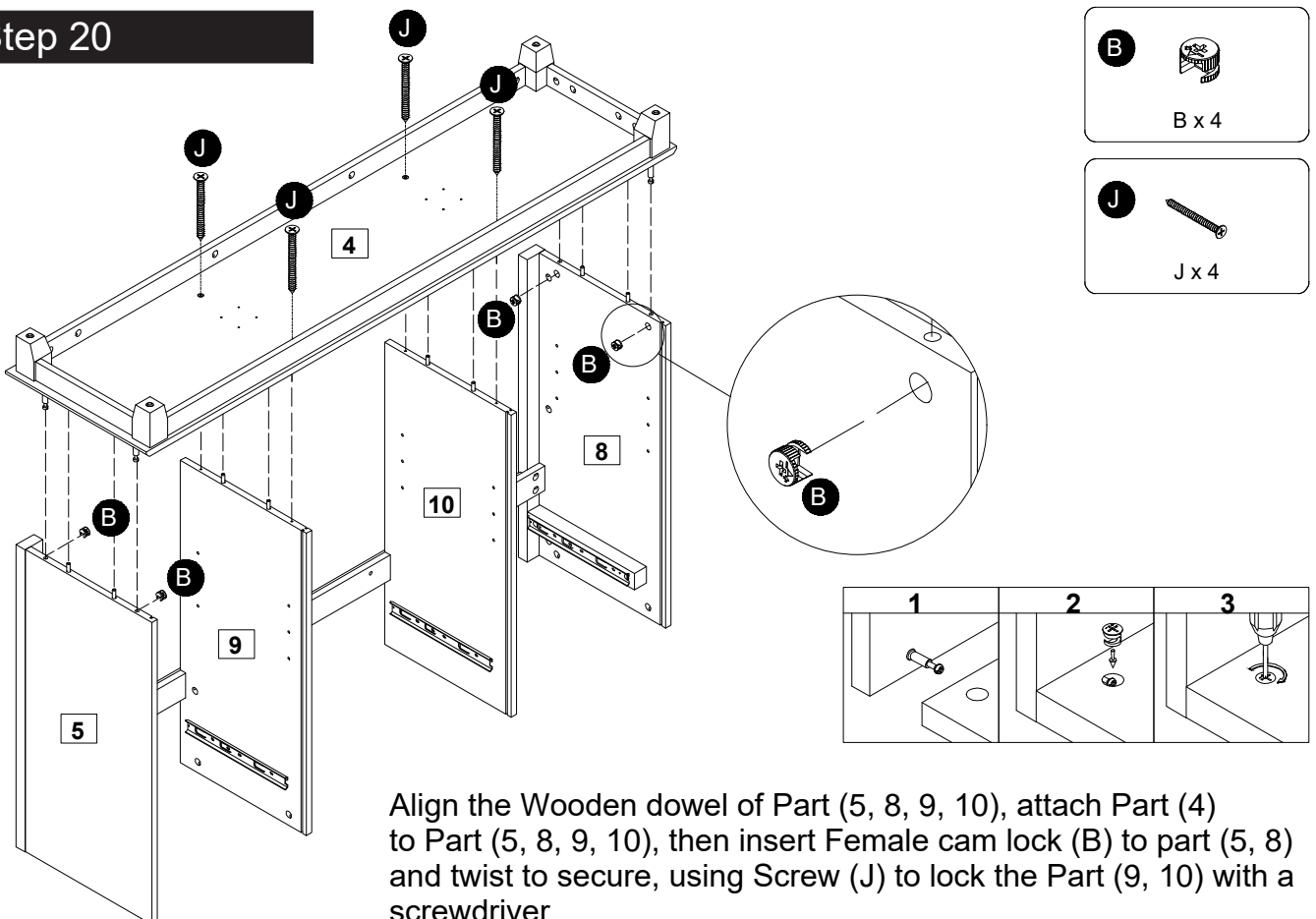

Assembly Instructions

Step 21

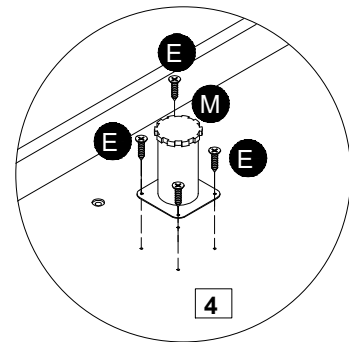
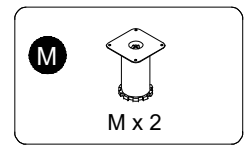
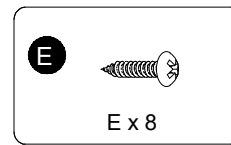
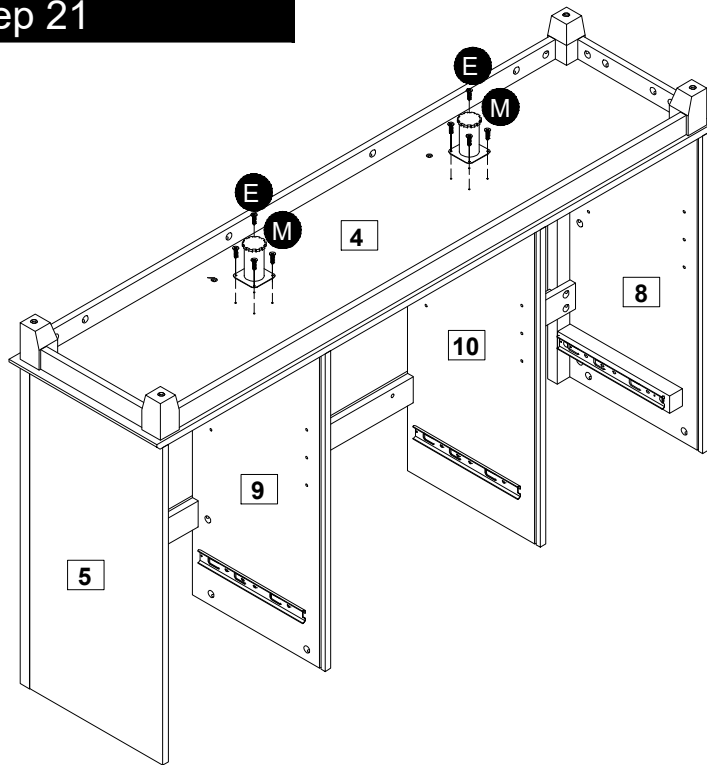

Attach Adjustable Feet (M) to Part (4) using screw (E) with a screwdriver.

Step 22

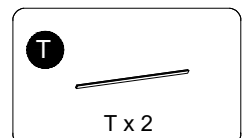
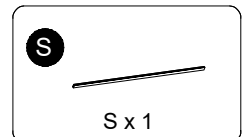
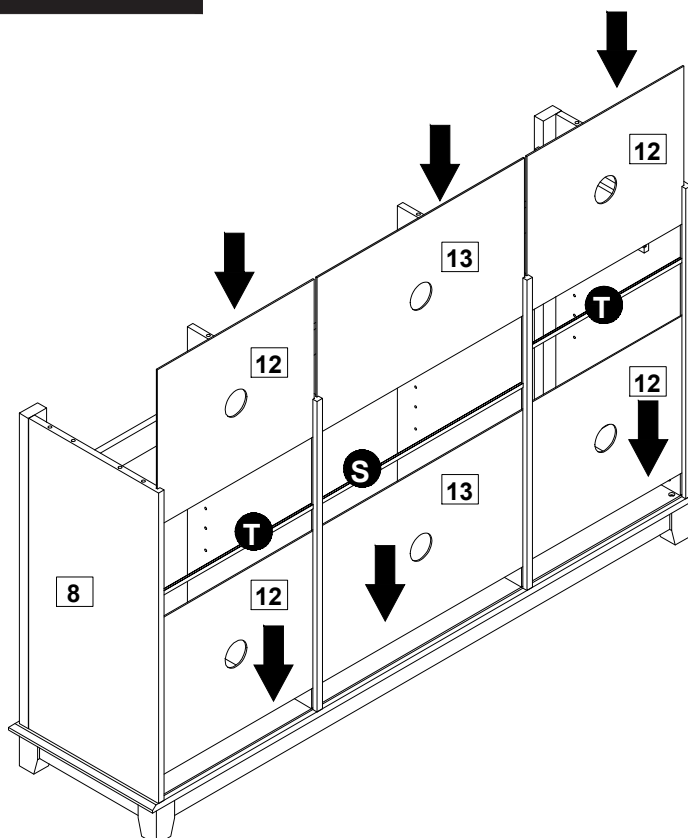

Insert the back panel (12, 13) to TV stand, and connect it with Rails (T, S) in the middle.

Assembly Instructions

Step 23

CAM-LOCK

Tighten until shoulder is flush with panel. Do not overtighten or undertighten (see example below)

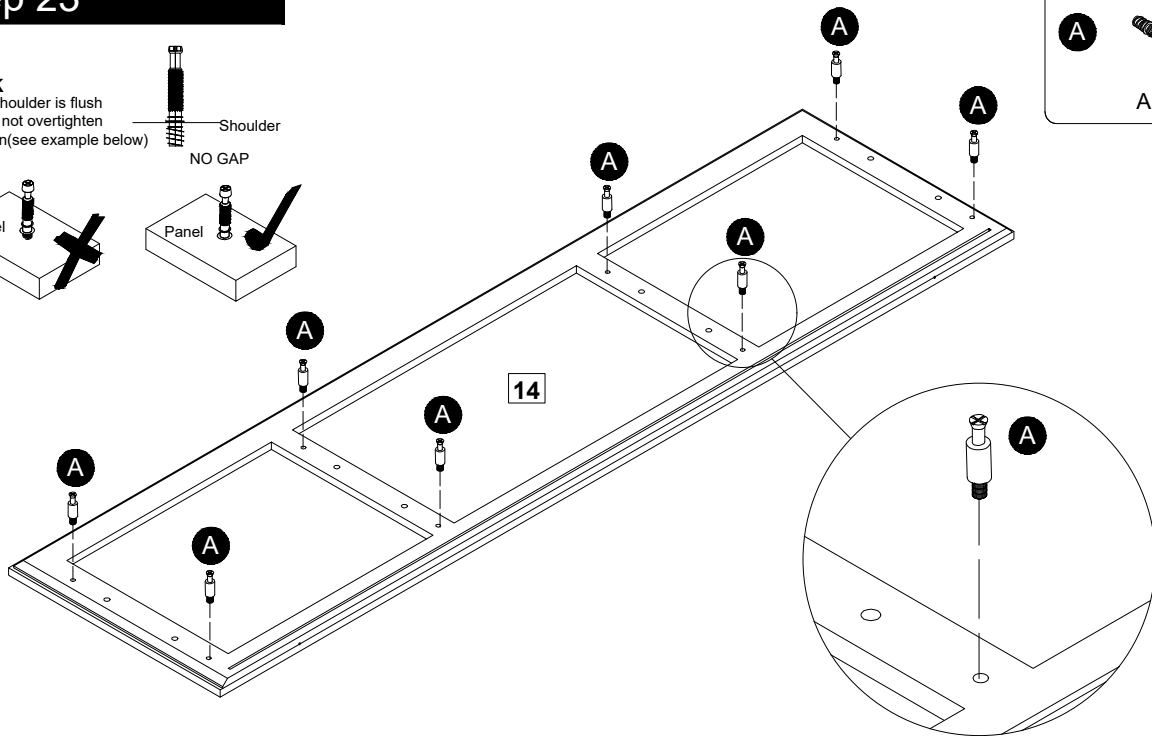
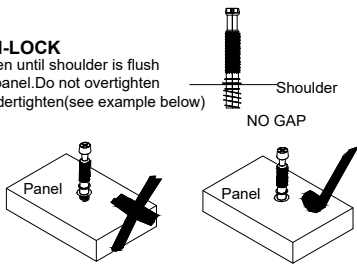

Attach cam bolt (A) to part (14) with a screwdriver.

Step 24

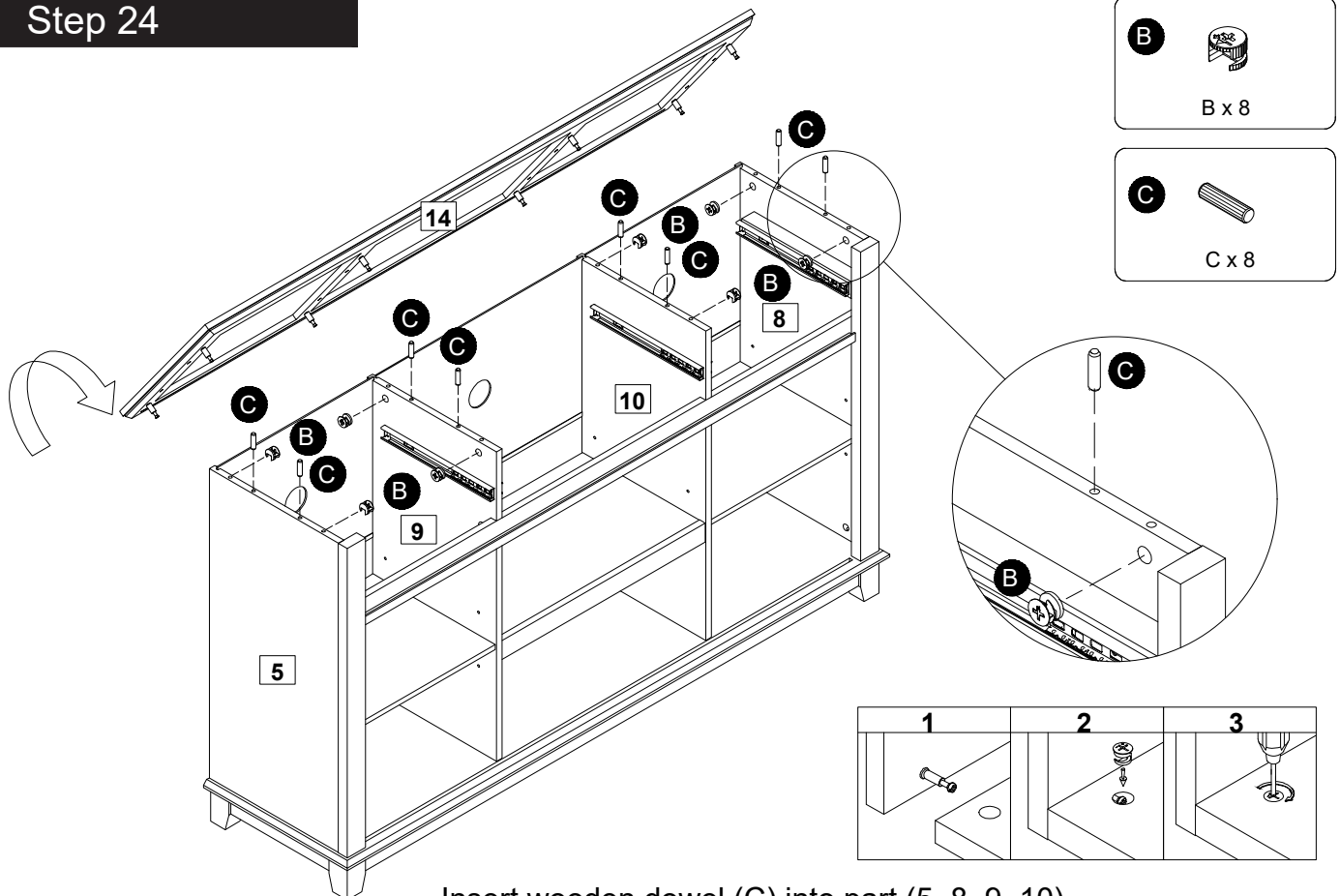

Insert wooden dowel (C) into part (5, 8, 9, 10).
Attach Part (14) to Parts (5, 8, 9, 10), Then insert
Female cam lock (B) and twist to secure.

Assembly Instructions

Step 25

CAM-LOCK

Tighten until shoulder is flush with panel. Do not overtighten or undertighten (see example below)

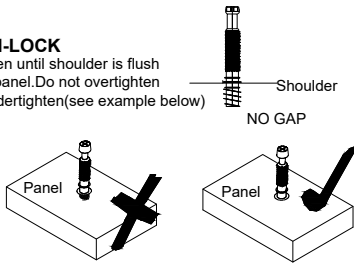

Step 25-1

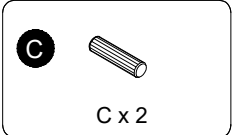
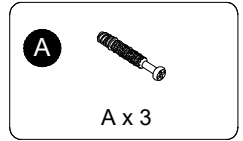
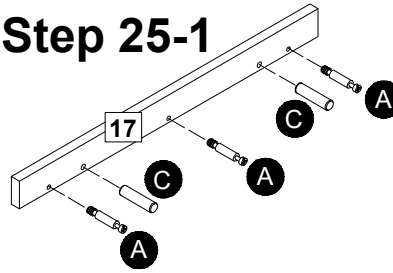

Step 25-2

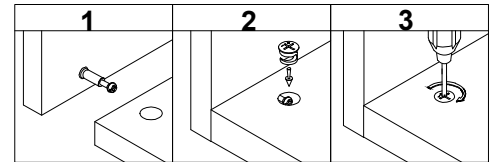
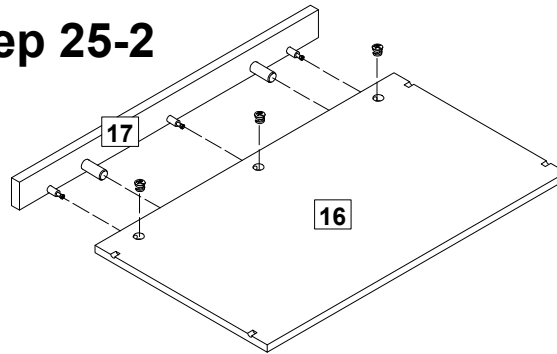

Step 25-1: Attach cam bolt (A) to part (17) with a screwdriver. Insert wooden dowel (C) into part (17).

Step 25-2: Attach part (17) to part (16), then insert Female cam lock (B) and twist to secure.

Step 26

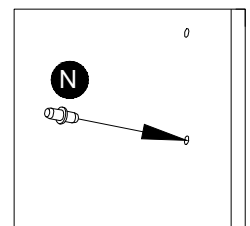
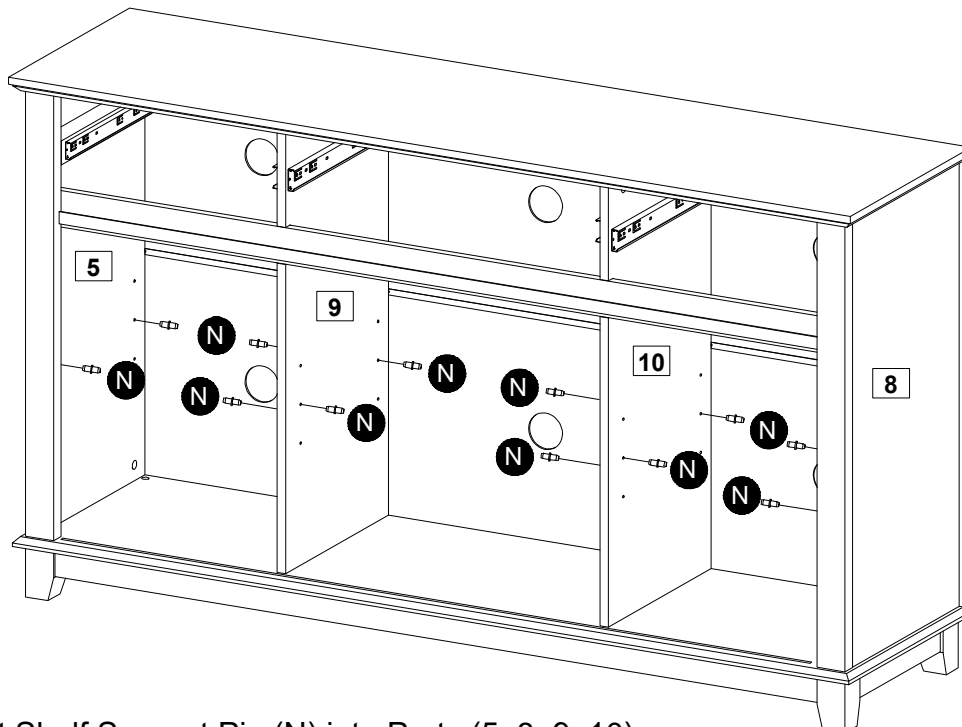
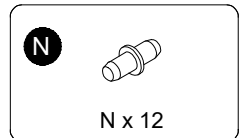

Insert Shelf Support Pin (N) into Parts (5, 8, 9, 10) there are 3 level of positions and you can choose one

Assembly Instructions

Step 27

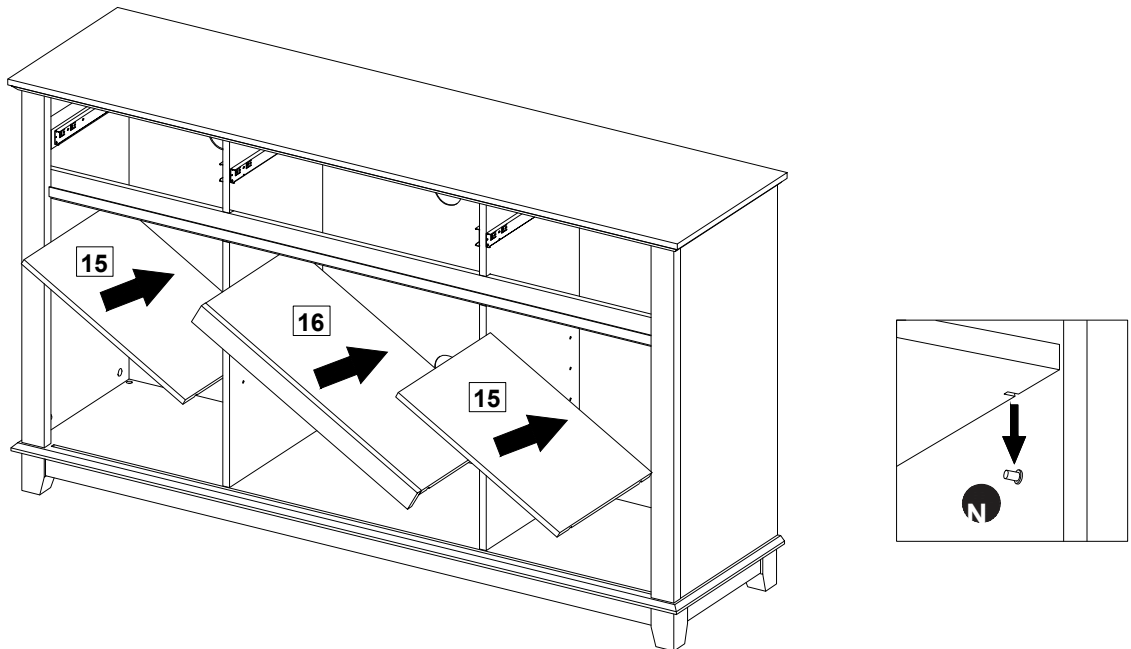

Place parts (15, 16) on top of the Support Pin. There are four grooves on each panel to fit.

Step 28

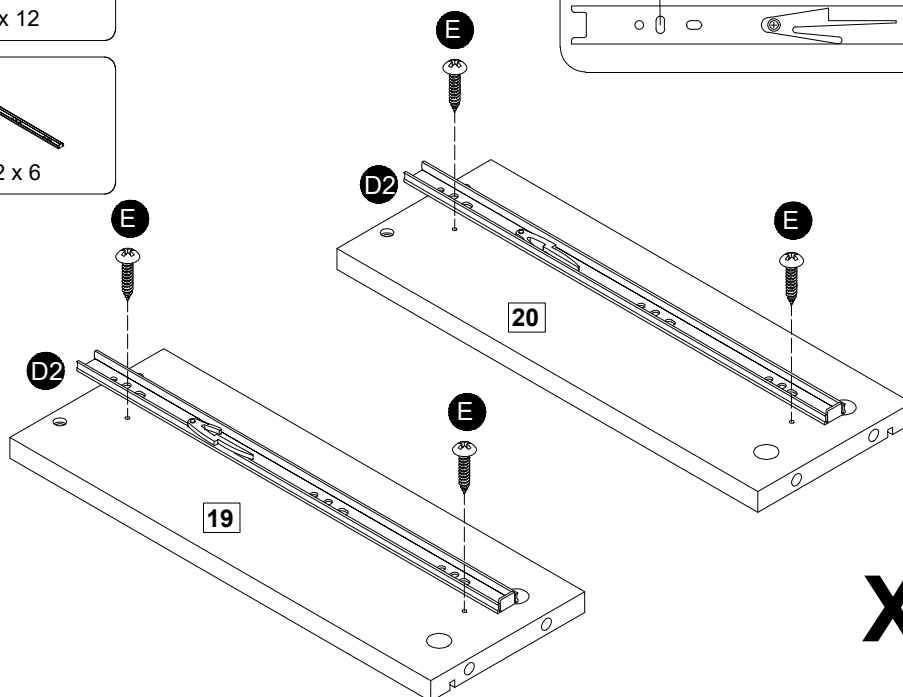
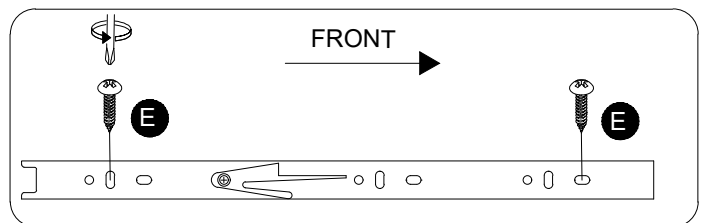
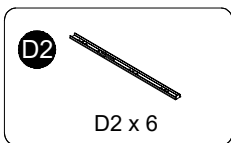
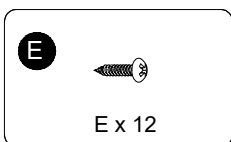

Attach Drawer slider (D2) to Parts (19, 20) align it with the Pre-drilled holes of Parts (19, 20) using Screw (E) with a screwdriver.

Assembly Instructions

Step 29

CAM-LOCK

Tighten until shoulder is flush with panel. Do not overtighten or undertighten (see example below)

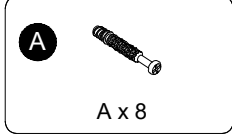
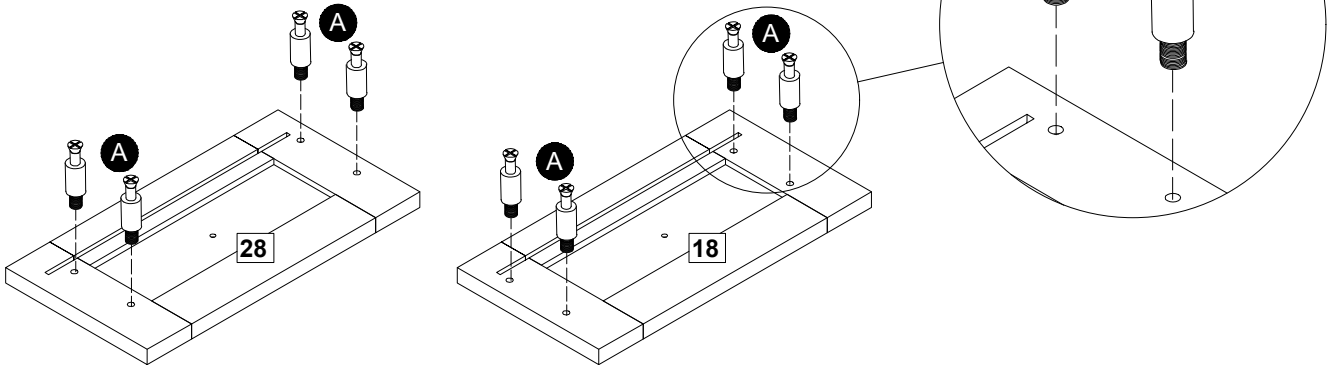
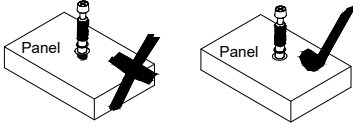
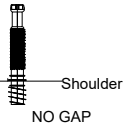

Attach cam bolt (A) to Parts (18, 28) with a screwdriver.

Step 30

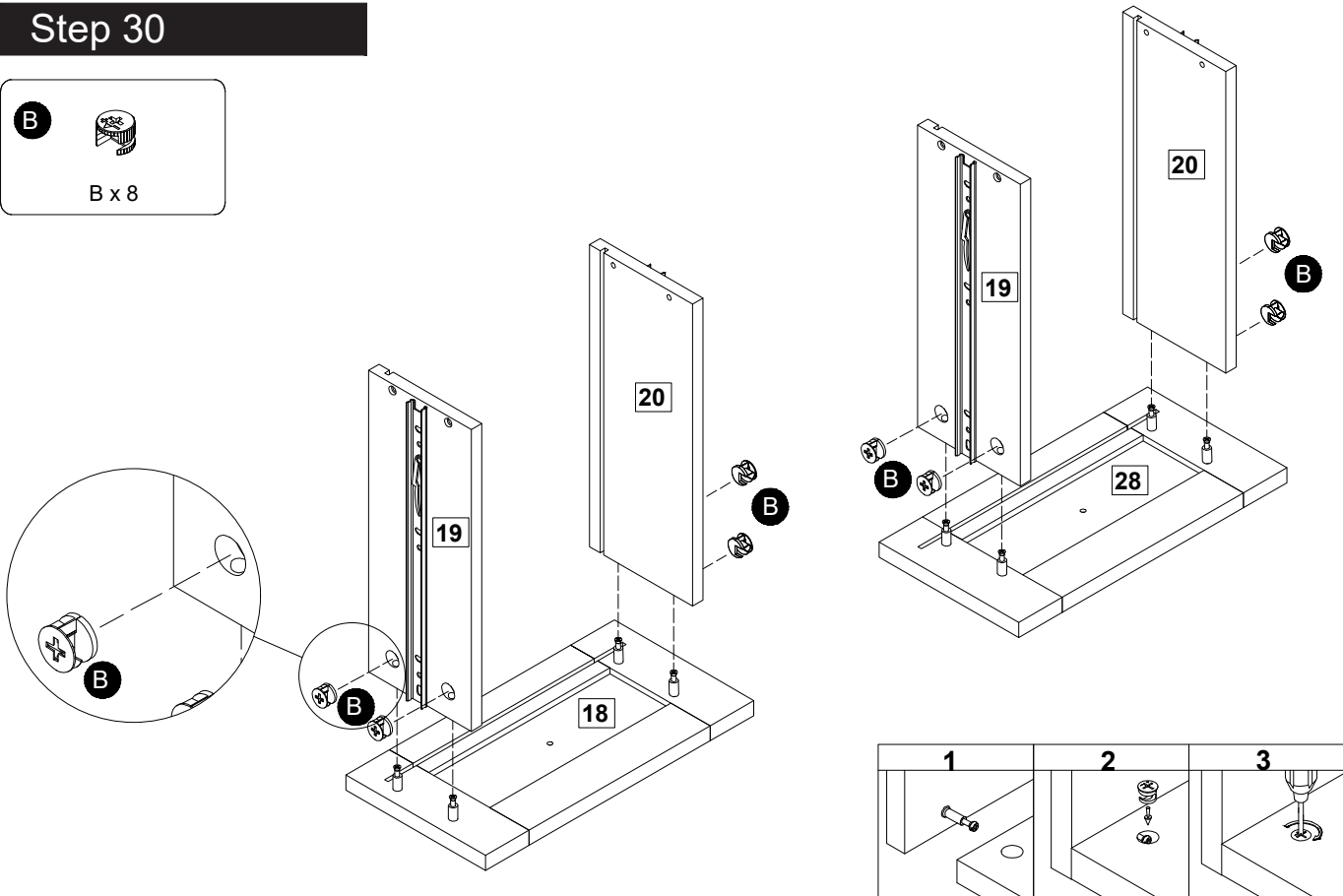

Insert Parts (19, 20) to Parts (18, 28) then insert Female Cam lock (B) and secure.

Assembly Instructions

Step 31

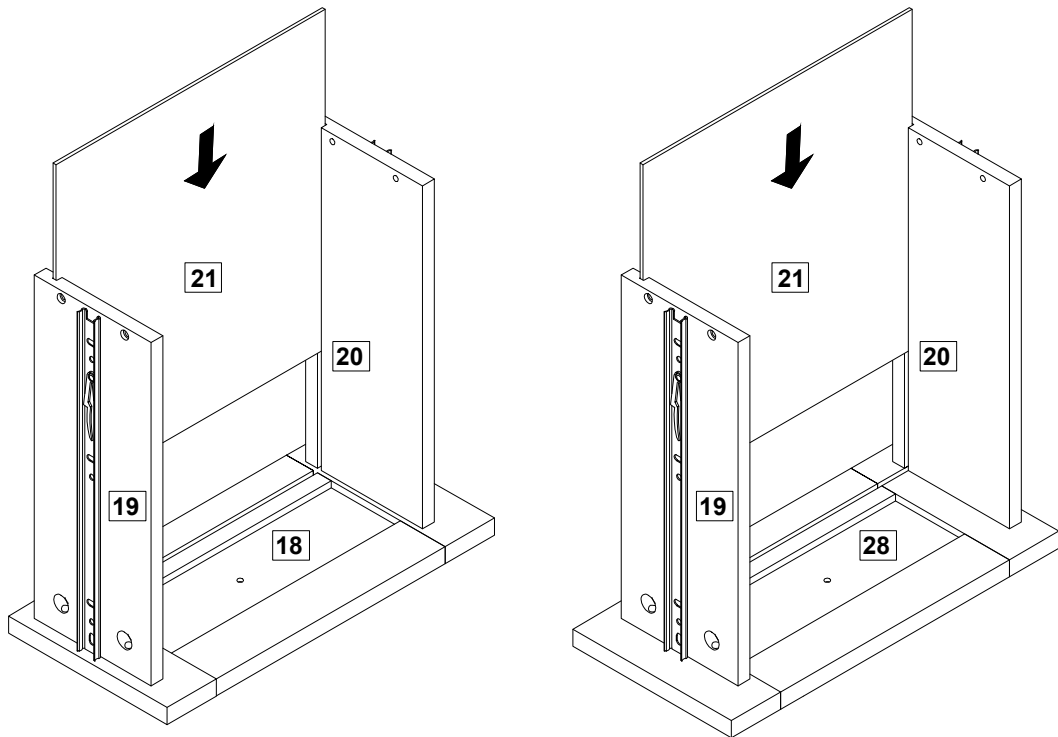

Insert Parts (21) into the groove of Parts (18, 19, 20, 28).

Step 32

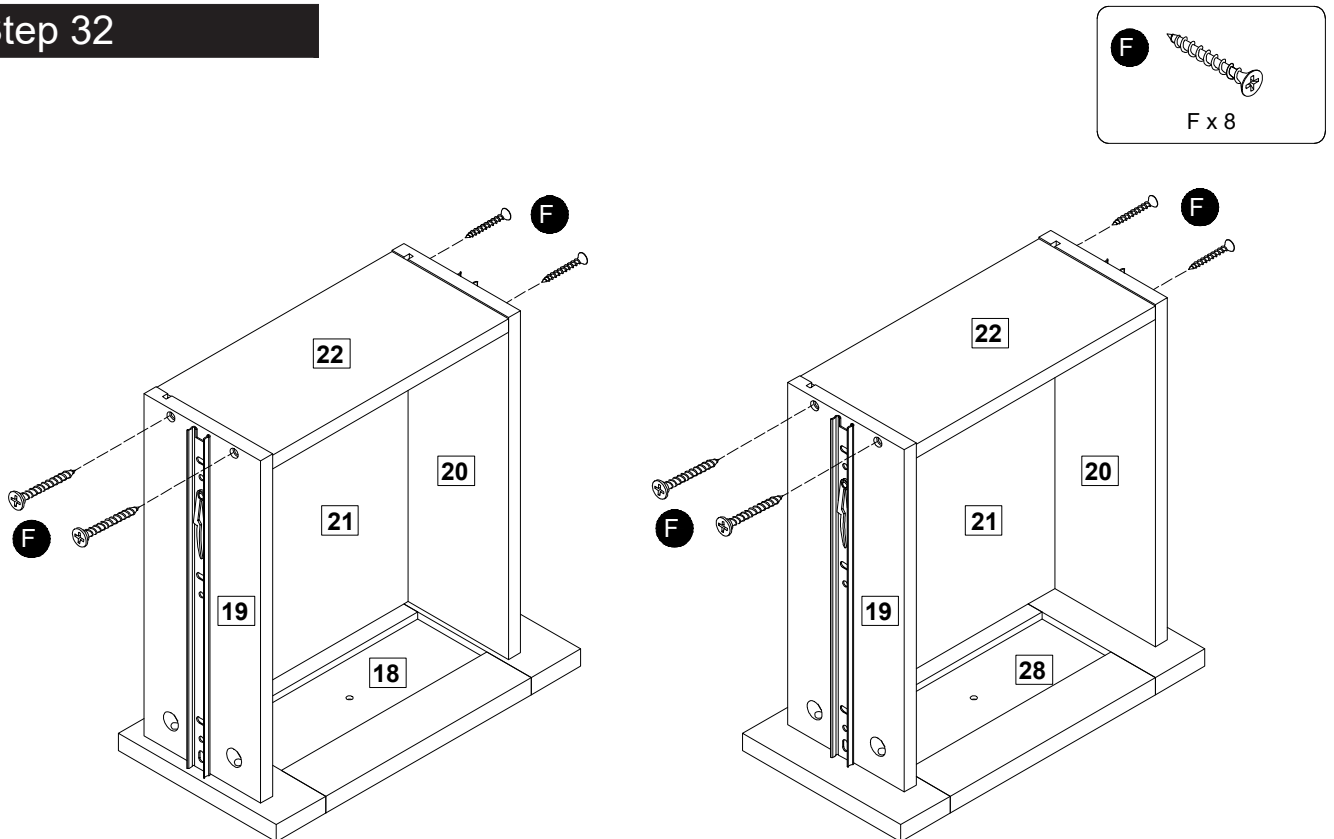

Attach Part (22) to Parts (19, 20, 21) then
Insert Screw (F) into the pre-drilled holes of Parts (19, 20), tighten it with a screwdriver.

Assembly Instructions

Step 33

CAM-LOCK

Tighten until shoulder is flush with panel. Do not overtighten or undertighten (see example below)

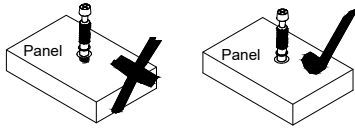
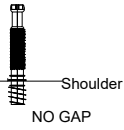

A x 4

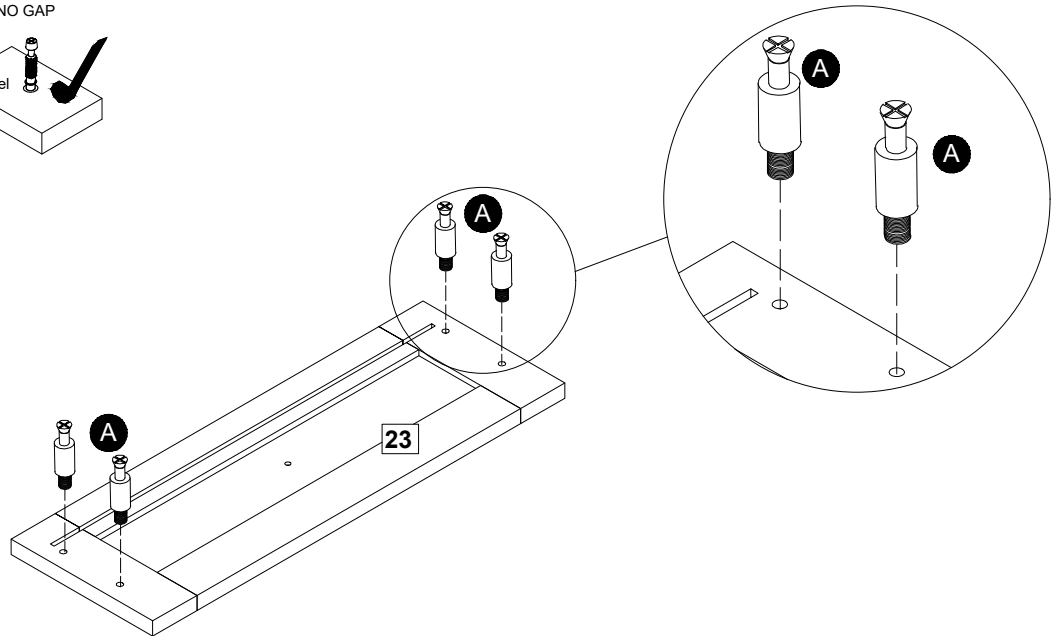

Attach cam bolt (A) to Part (23) with a screwdriver.

Step 34



B x 4

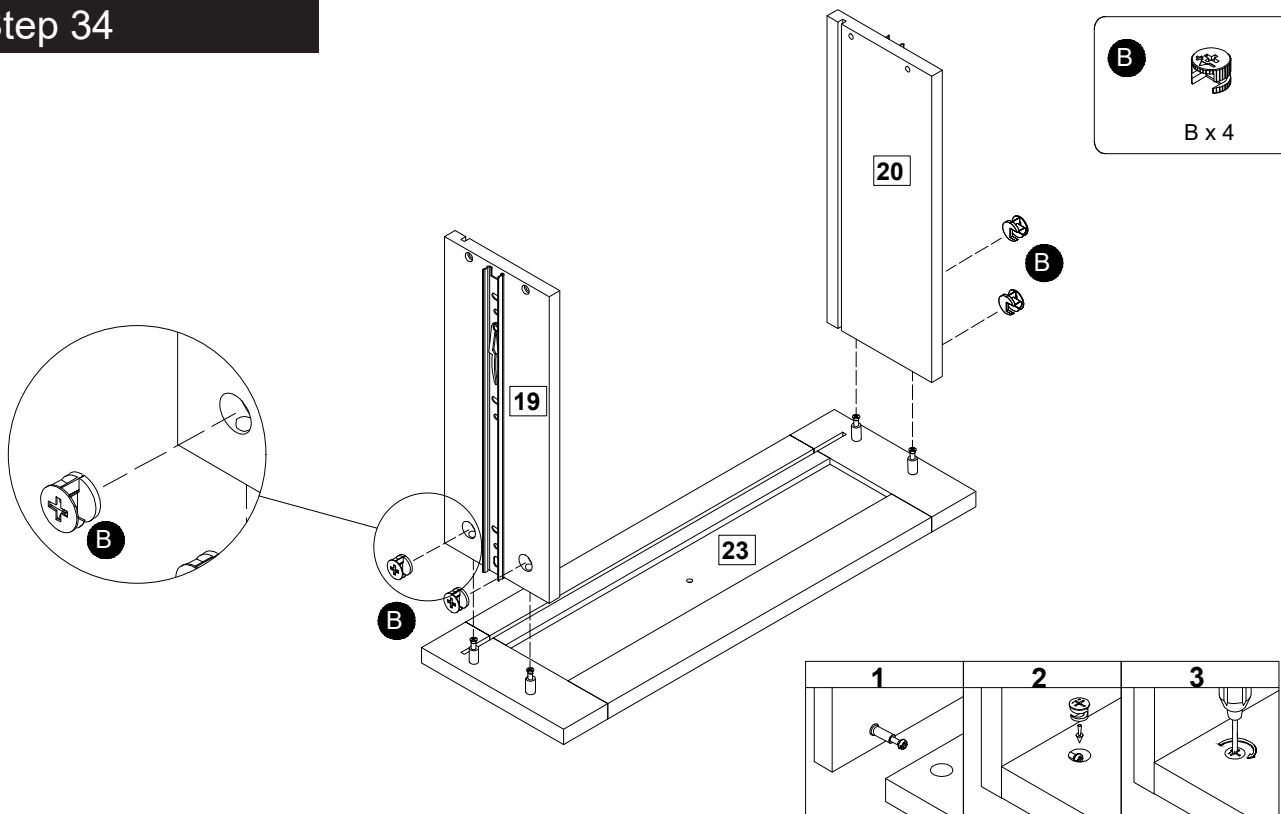

Insert Parts (19, 20) to Part (23) then insert Female Cam lock (B) and secure.

Assembly Instructions

Step 35

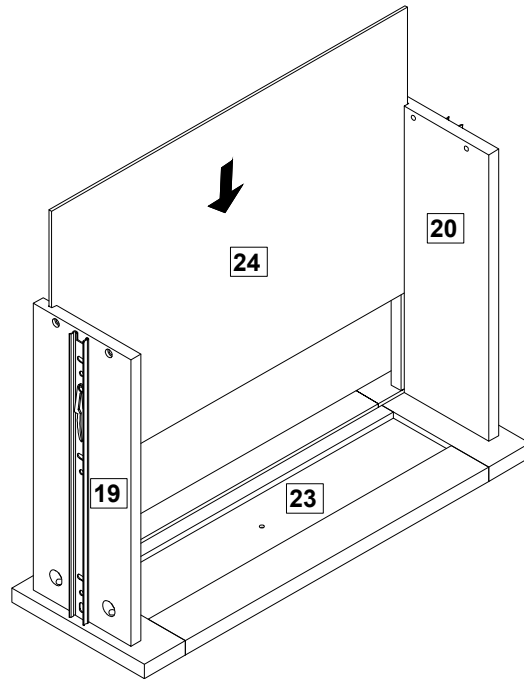

Insert Parts (24) into the groove of Parts (19, 20, 23).

Step 36

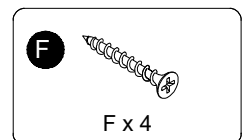
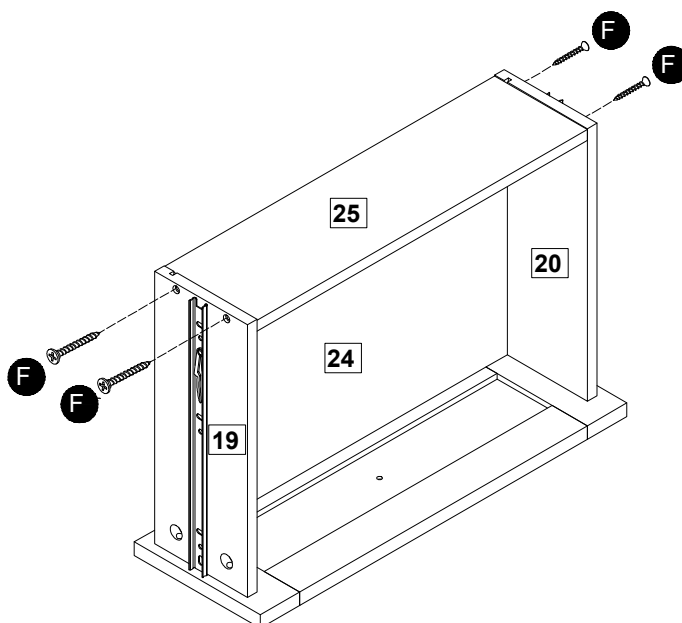

Attach Part (25) to Parts (19, 20, 24) then
Insert Screw (F) into the pre-drilled holes on Parts (19, 20), tighten it with a screwdriver.

Assembly Instructions

Step 37

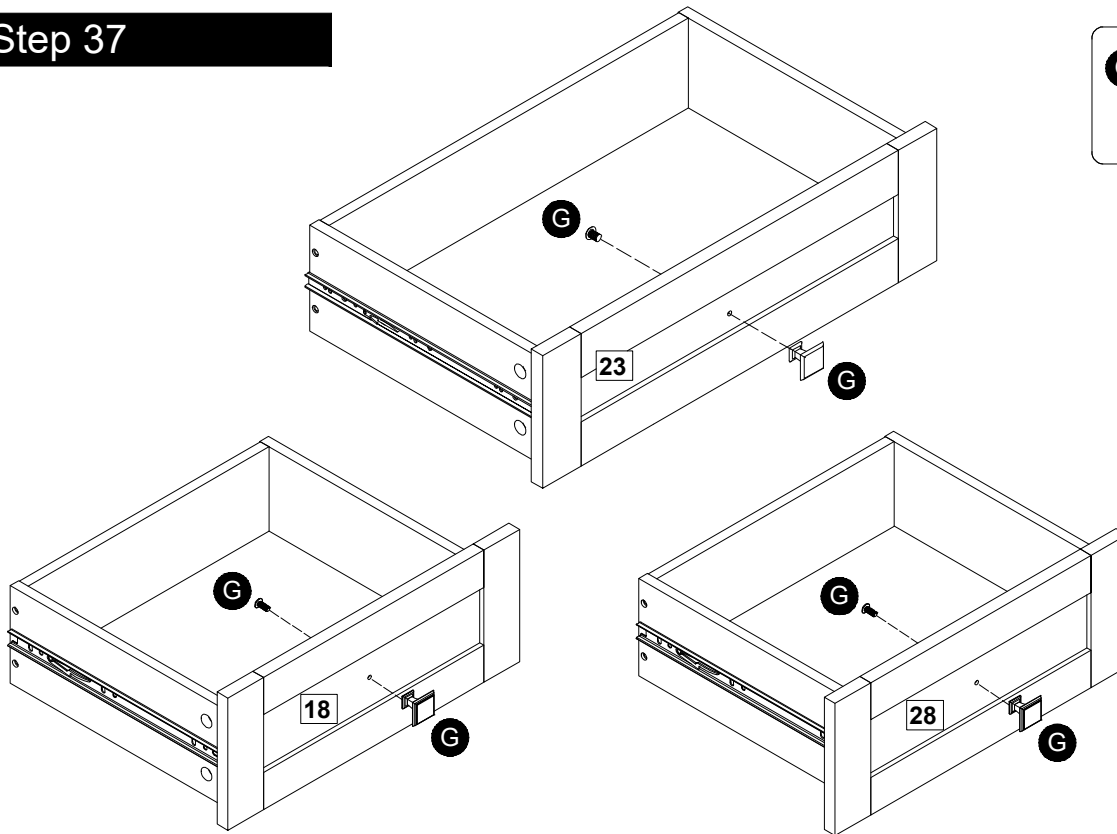

Attach Handle (G) to Parts (18, 23, 28) using Screw (G) with a screwdriver.
Please note: Handles and screws are in one plastic bag.

Step 38

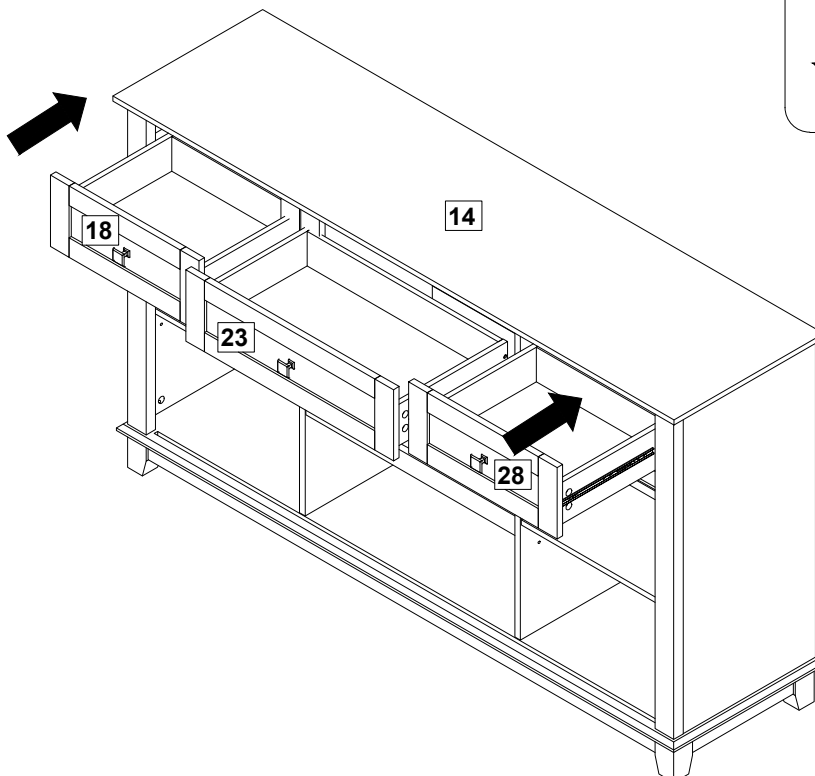

Attention:

1. Align the slide runners on the drawer with the unit and push it carefully inside until it stops.

★ If the drawer does not go in smoothly please take it out and repeat the step.

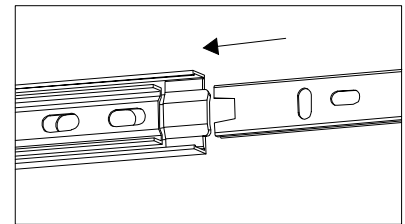

Assembly Instructions

Step 39

V



V x 8

O

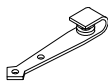

O x 4

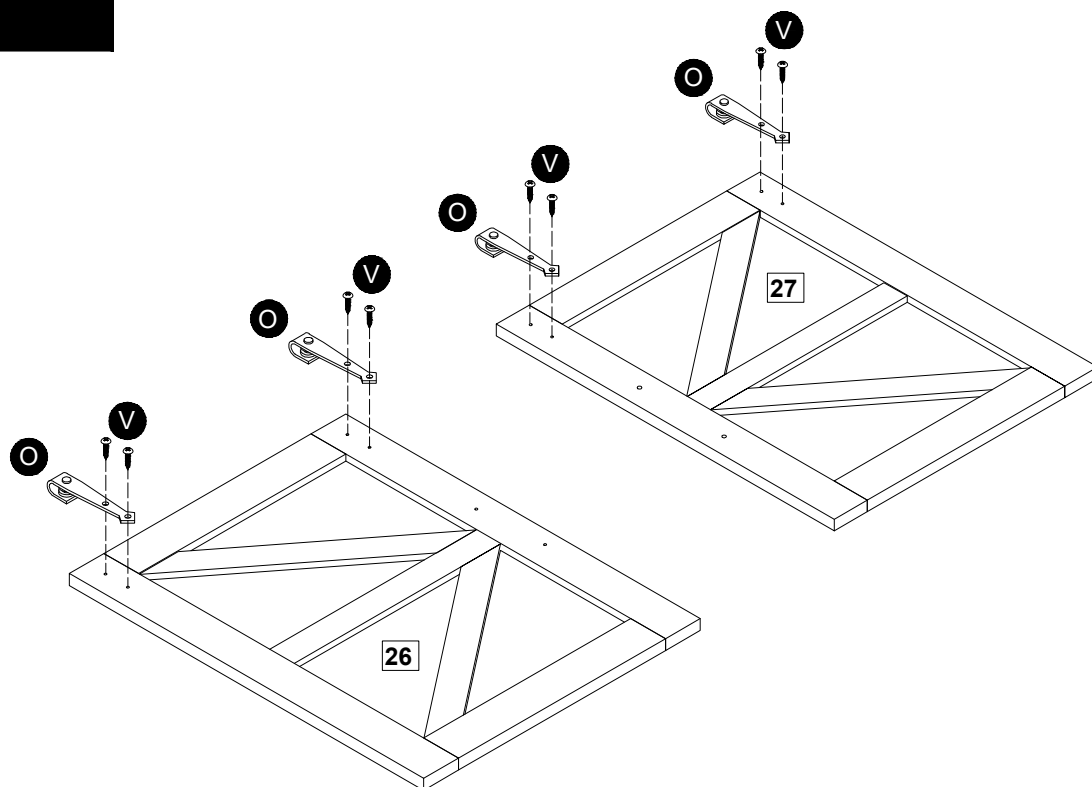

Attach Pulley (O) to Parts (26, 27) using Screw (V) with a screwdriver.

Step 40

Q



Q x 8

P



P x 4

L



L x 2

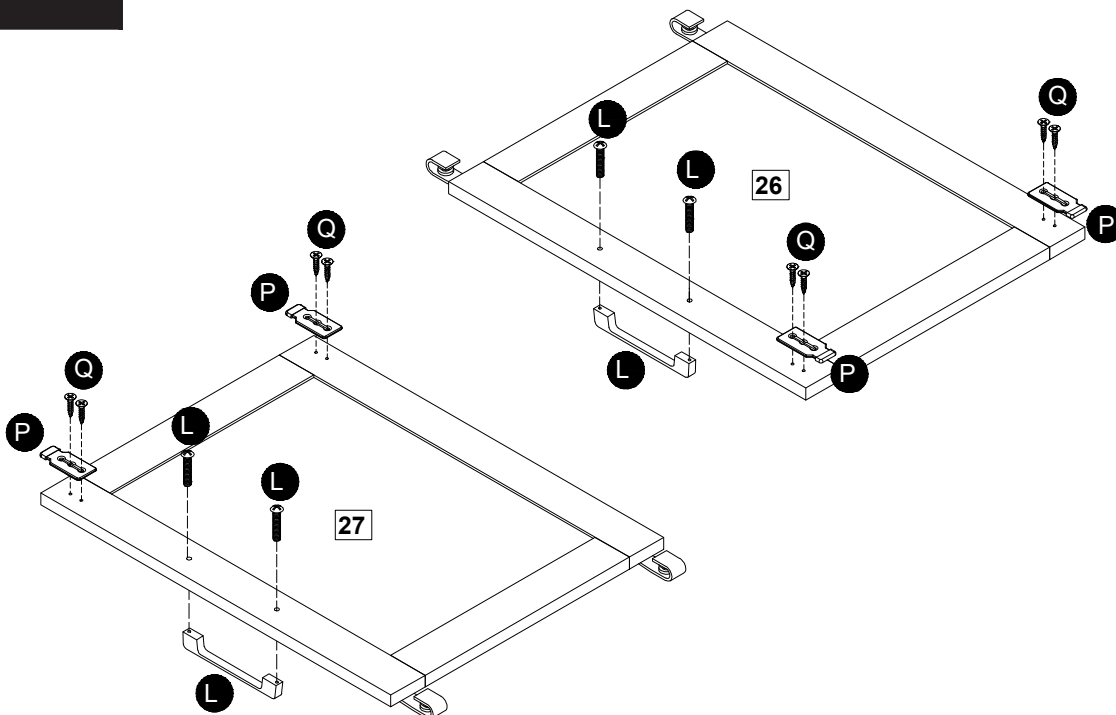

Attach Plate (P) to Parts (26, 27) using Screw (Q) with a screwdriver.
Attach Handle (L) to Parts (26, 27) using Screw (L) with a screwdriver.
Please note: Handles and screws are in one plastic bag.

Assembly Instructions

Step 41

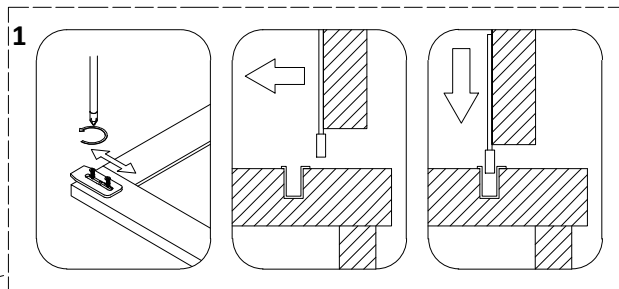
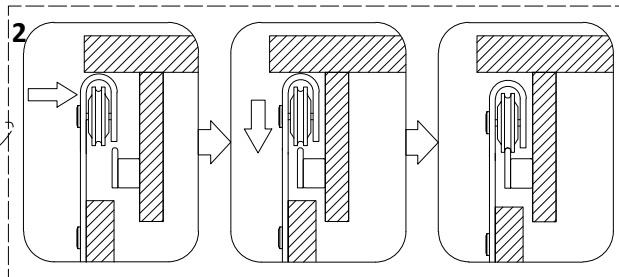
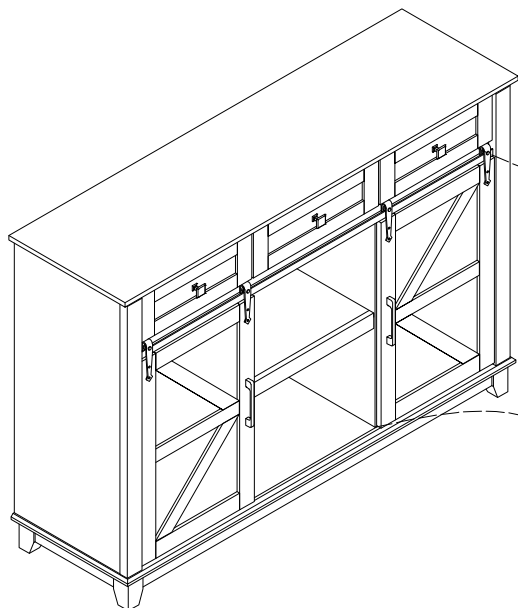

Attach bottom of doors to the sliding slot then close the doors to the sliding track.
Slightly uplift the doors and hook pulley to the sliding track.

Step 42

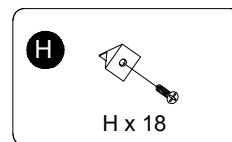
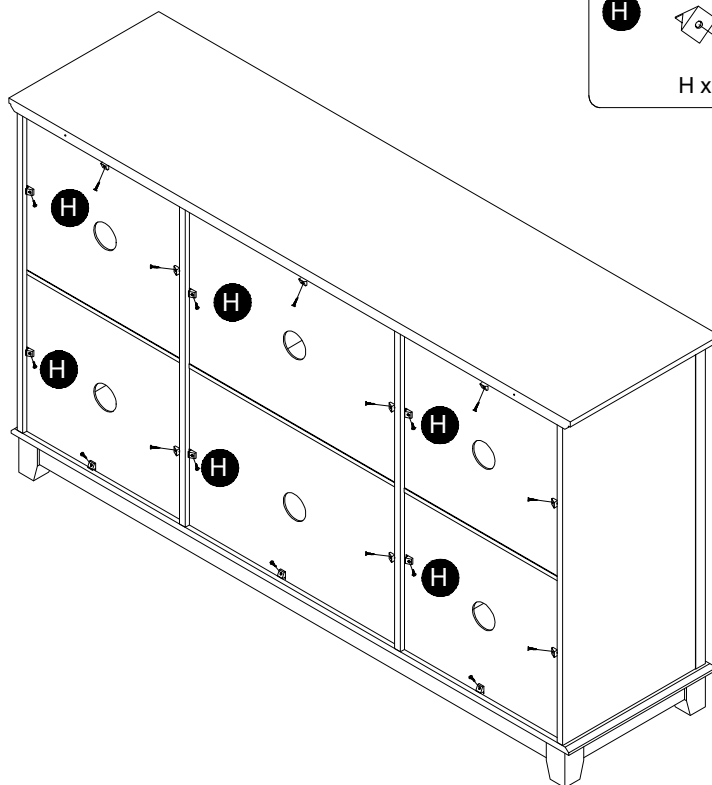
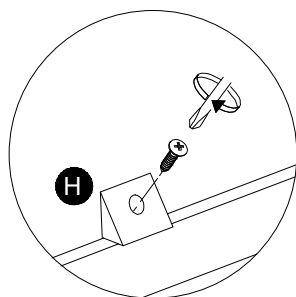
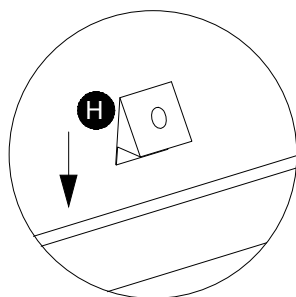

Insert Plastic wedge (H) to the back panel using Screw (H).
The position in the manual for your reference.

Assembly Instructions

Step 43

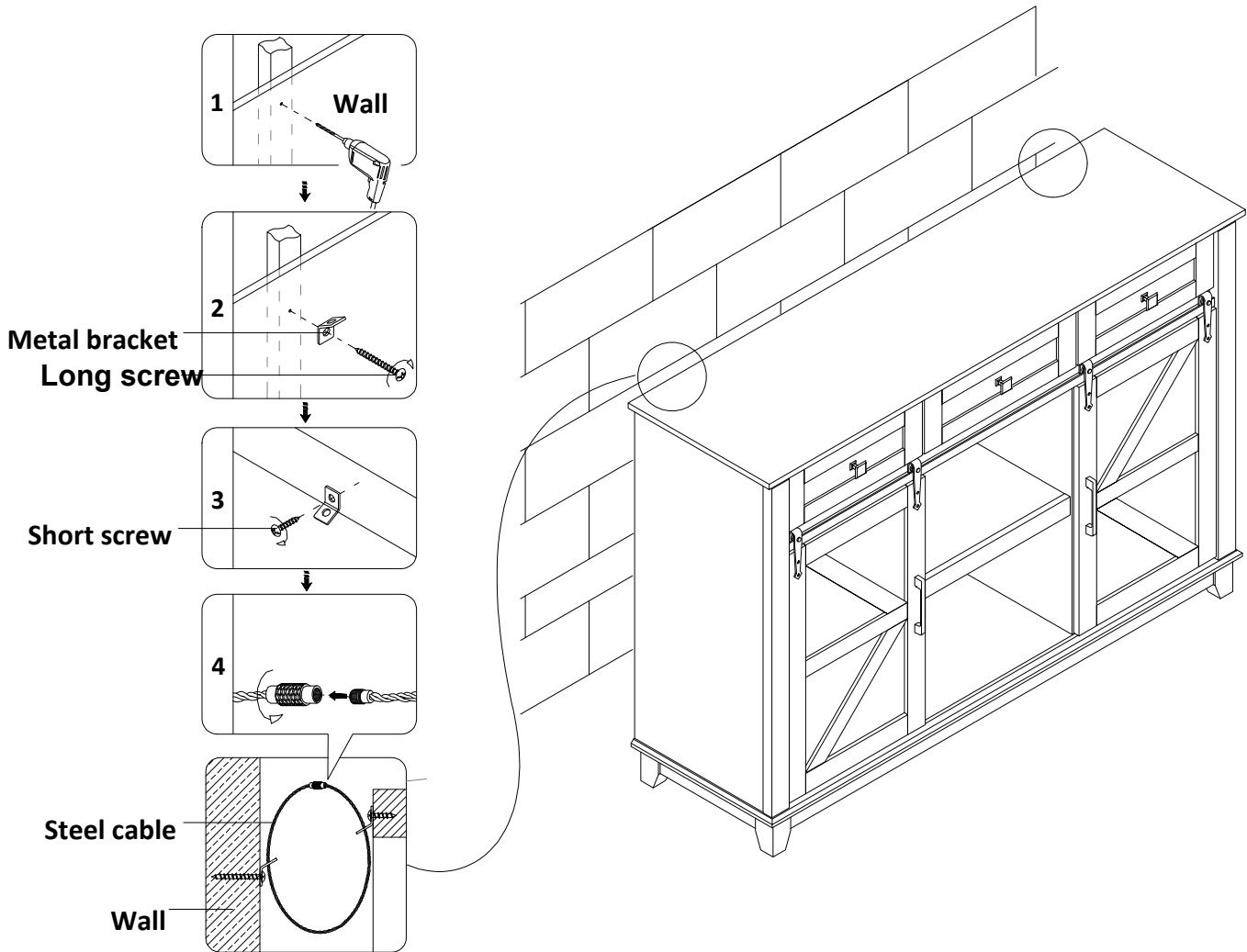
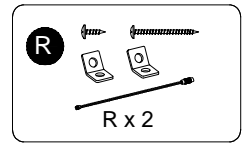

Follow the instructions printed on the plastic bag containing the Tipping Restraint Hardware to attach the tip-over restraints to the unit and the wall.

Assembly is complete.

A Guide to Wall Mounting & Fixings

Important note:

If plastic wall plugs (rawl plugs) are supplied with your product, e.g.:



- these are only suitable for use in masonry walls.

If you are in any doubt about the correct wall plugs for your wall, seek professional advice.

Failure of the product due to using the incorrect fixings is the responsibility of the installer.



Important: when drilling into walls always check that there are no hidden wires or pipes etc.

Make sure that the screws and wall plugs being used are suitable for **supporting your unit**. **Consult a qualified tradesperson if you are unsure.**

Hints:

- 1: General rule:  always use a larger screw and wall plug if you are not sure.
- 2: Ensure you use the recommended drill bit to match the wall plug and hole size.
- 3: Ensure you drill the hole horizontally; do not force the drill or enlarge the hole.
- 4: Take extra care when drilling high walls, ceilings and ceramic tiles. Ensure wall plugs are inserted beyond the thickness of the ceramic tiles to avoid the tiles splitting or cracking.
- 5: Ensure wall plugs are well fitted and are a tight fit in the drilled hole.

Types of walls

You can use one of the following types of wall plug if your walls are made of brick, breeze block, concrete, stone or wood.

No.1 "General Purpose" wall plug

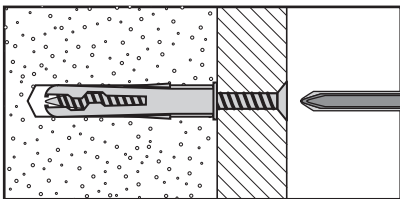

Generally aerated blocks should not be used to support heavy loads, use a specialist fitting in this case. For light loads, general purpose wall plugs can be used.

No.3 "Cavity Fixing" wall plug

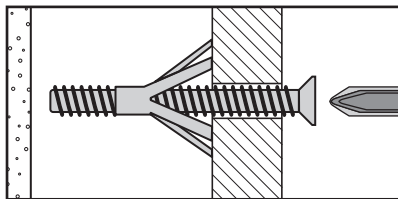

For use with plasterboard partitions or hollow wooden doors.

No.5 "Hammer Fixing" wall plug

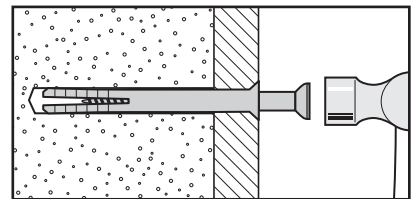

For use with walls stuck with plasterboard. The hammer fixing allows it to be fixed to the wall rather than the plasterboard. Always check the fixing is secure to the retaining wall.

No.2 "Plasterboard" wall plug

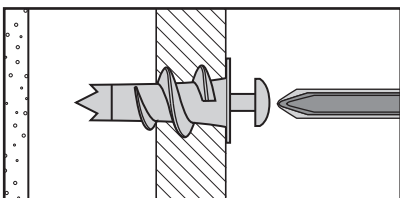

For use when attaching light loads onto plasterboard partitions.

No.4 "Cavity Fixing - Heavy Duty" wall plug

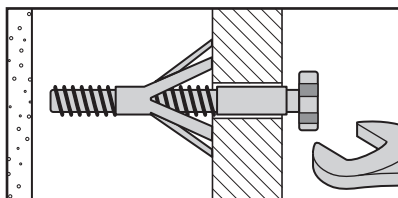

For use when fitting or supporting heavy loads such as shelving, wall cabinets and coat racks.

No.6 "Shield Anchor" wall plug - heavy loads

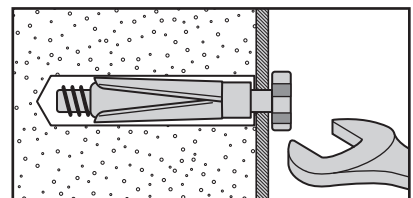

For use with heavier loads such as TV and HiFi speakers and satellite dishes etc.



Care & Maintenance

Safety: always check the fitting and location to ensure your safety in and around the home.

Fitting: from time to time check the fitting to ensure the wall plugs or screws do not become loose.