

ASSEMBLY INSTRUCTION

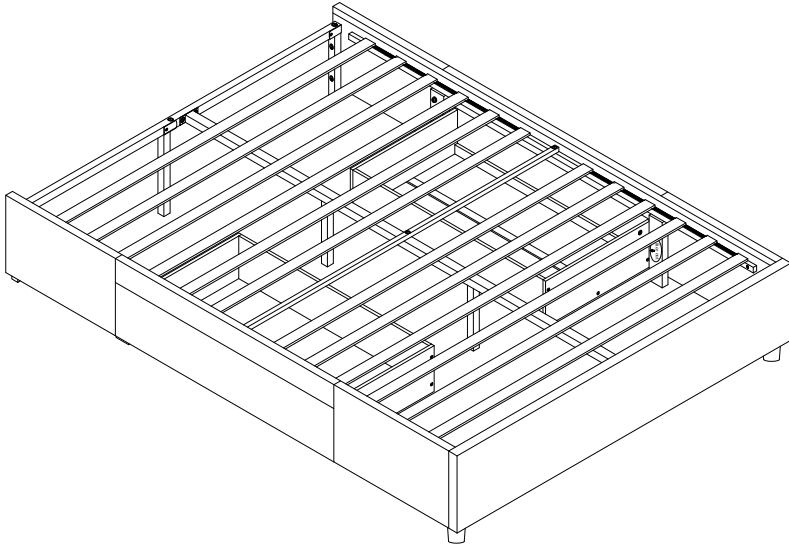

Please **TEAR OFF** this shrink film from side!
DO NOT USE CUTTER!

ITEM NUMBER:196

IMPORTANT NOTE

1. For the protection of your furniture, place all parts on a clean and smooth surface to prevent any damage.
2. Keep fittings out of children's reach and keep children well away from construction area.
3. When moving your assembled bed. it is best to lift the bed and never to drag it.
4. Do not use this product if parts are missing, damaged or worn.
5. This product should only be used on firm, level ground.
6. Please periodically check all fittings and re-tighten as necessary.
7. Do not use the bed unless all bolts and screws are firmly secured.
8. For further assistance, please provide a screenshot of your order and contact us via email at kjbed@outlook.com

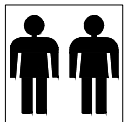

Minimum two
person assembly

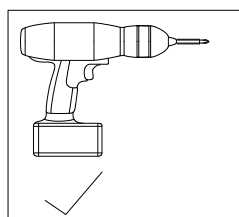



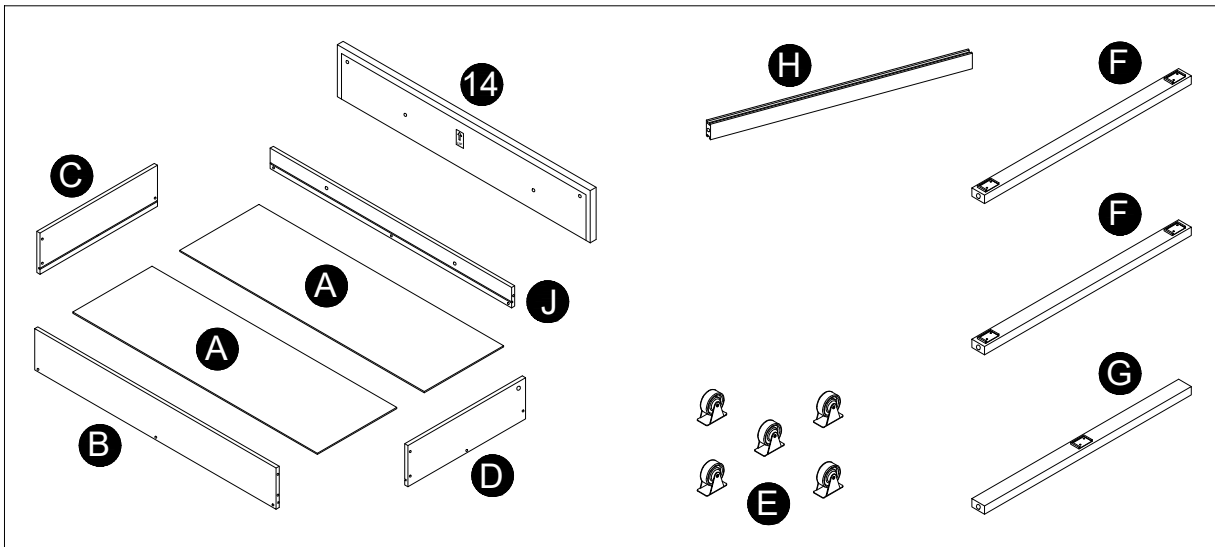
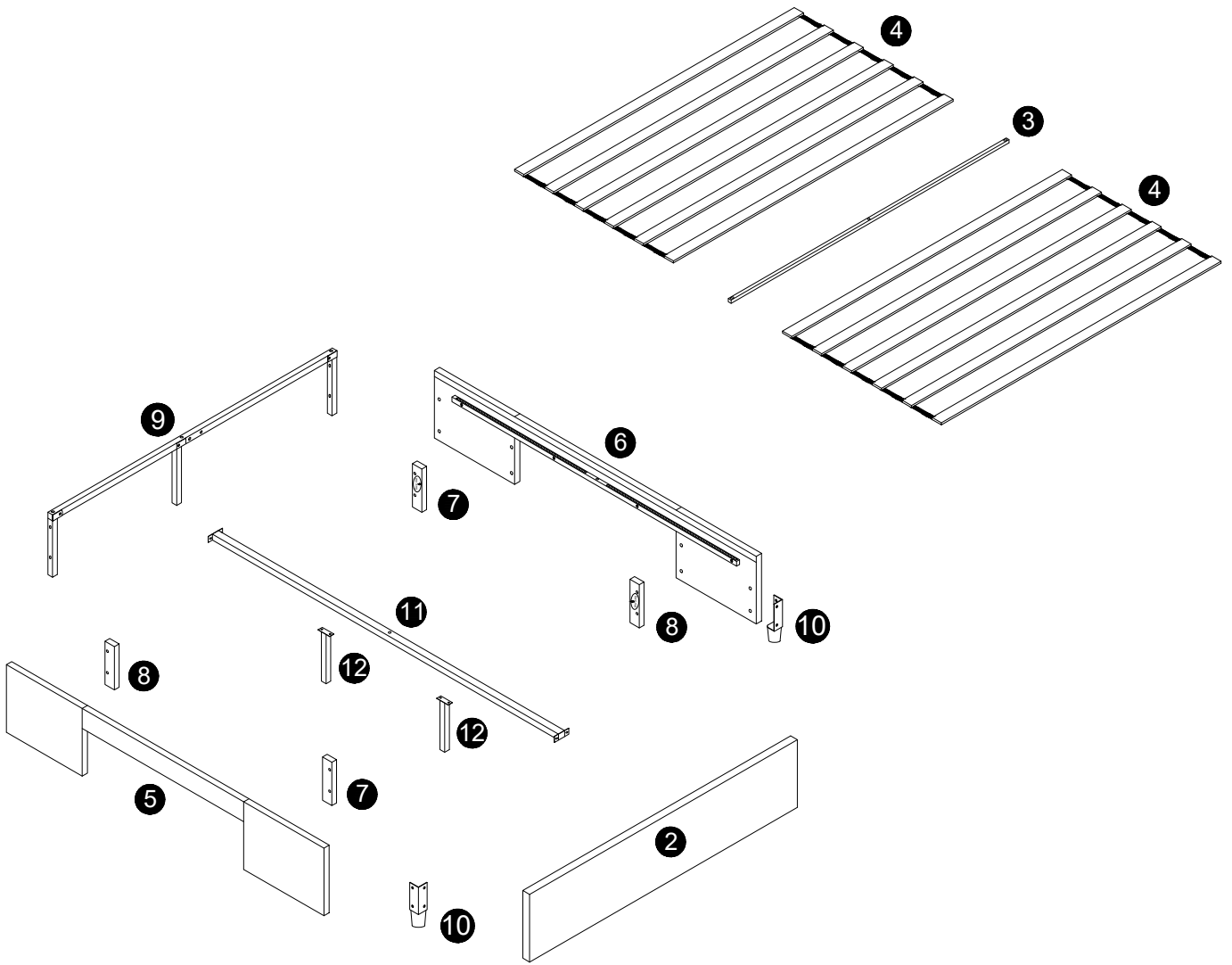



PART LIST

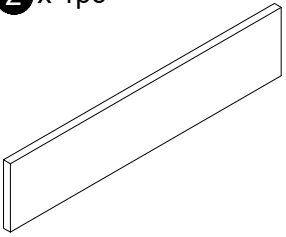
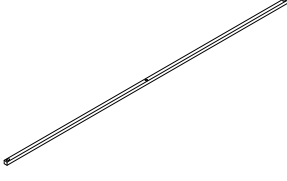
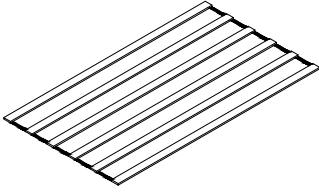
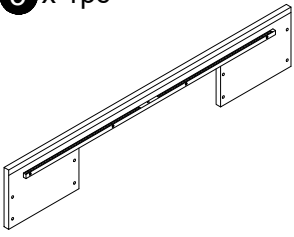
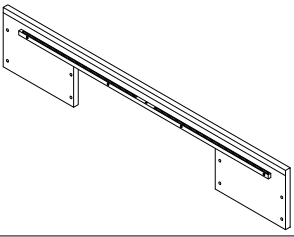
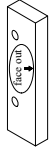

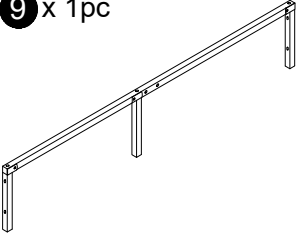

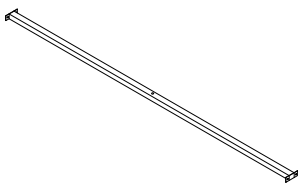
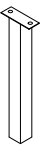
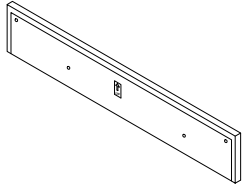
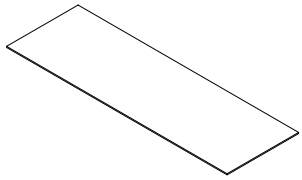
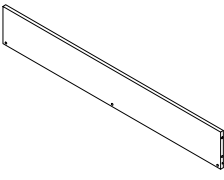
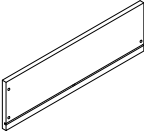
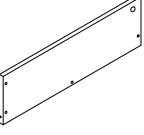

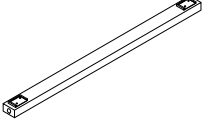
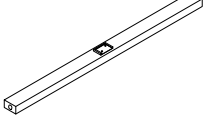
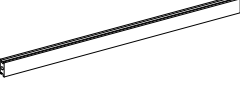
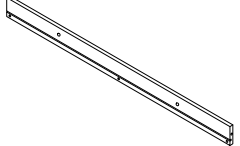



x2

PART LIST

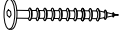
2 x 1pc 	3 x 1pc 	4 x 2pcs 	5 x 1pc 	
6 x 1pc 	7 x 2pcs 	8 x 2pcs 	9 x 1pc 	
10 x 2pcs 	11 x 1pc 	12 x 2pcs 	14 x 2pcs 	
A x 4pcs 	B x 2pcs 	C x 2pcs 	D x 2pcs 	
E x 10pcs 	F x 4pcs 	G x 2pcs 	H x 2pcs 	J x 2pcs 

HARDWARE LIST

 H1 M5 x 1pc	 H2 M8x20mm x 16pcs	 H3 M8x30mm x 4pcs	 H4 M8x40mm x 14pcs	
 H5 M8x45mm x 4pcs	 H10 M6x45mm x 28pcs	 H11 M4 x 1pc	 H12 x 4pcs	 H13 x 4pcs

Please ensure to thoroughly inspect the small inner cardboard box containing the hardware, which are tied with a red string, before disposing of the box.

1

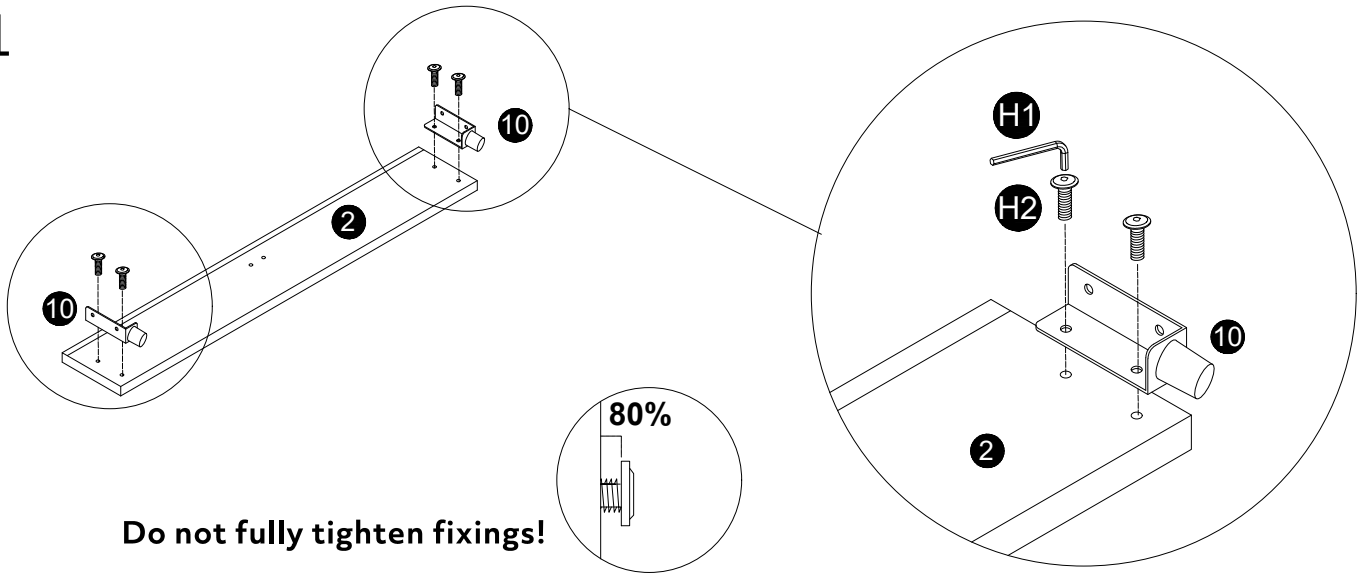

2

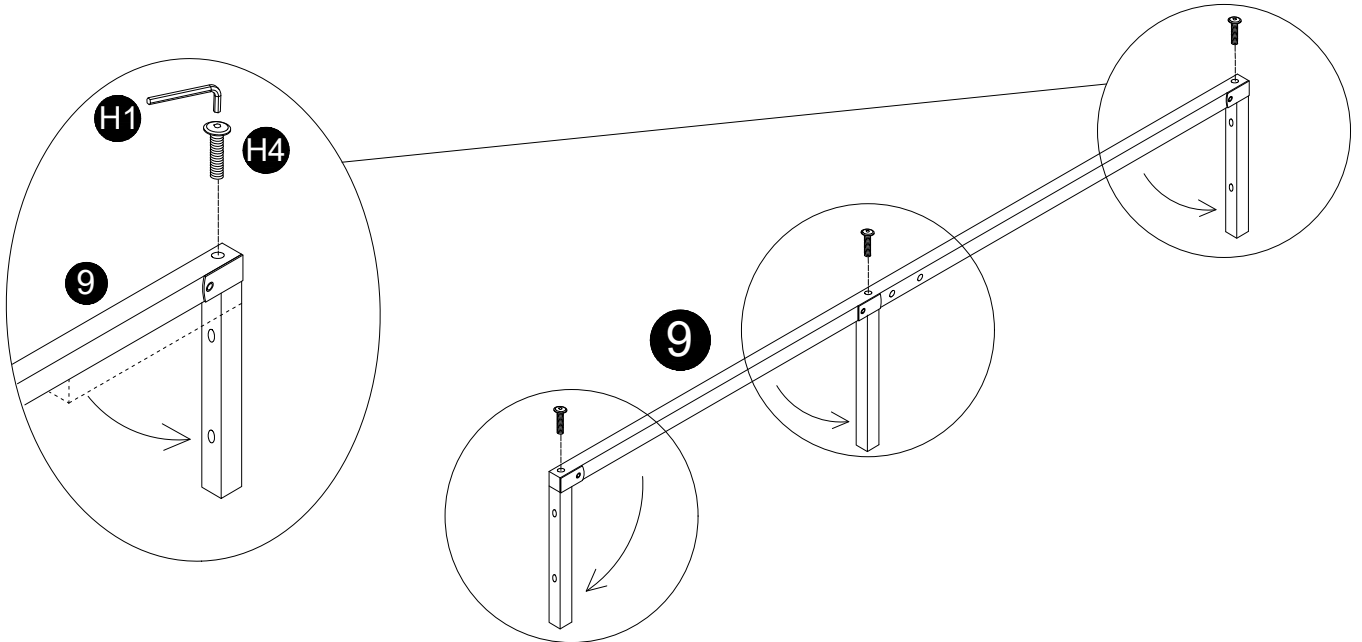

3

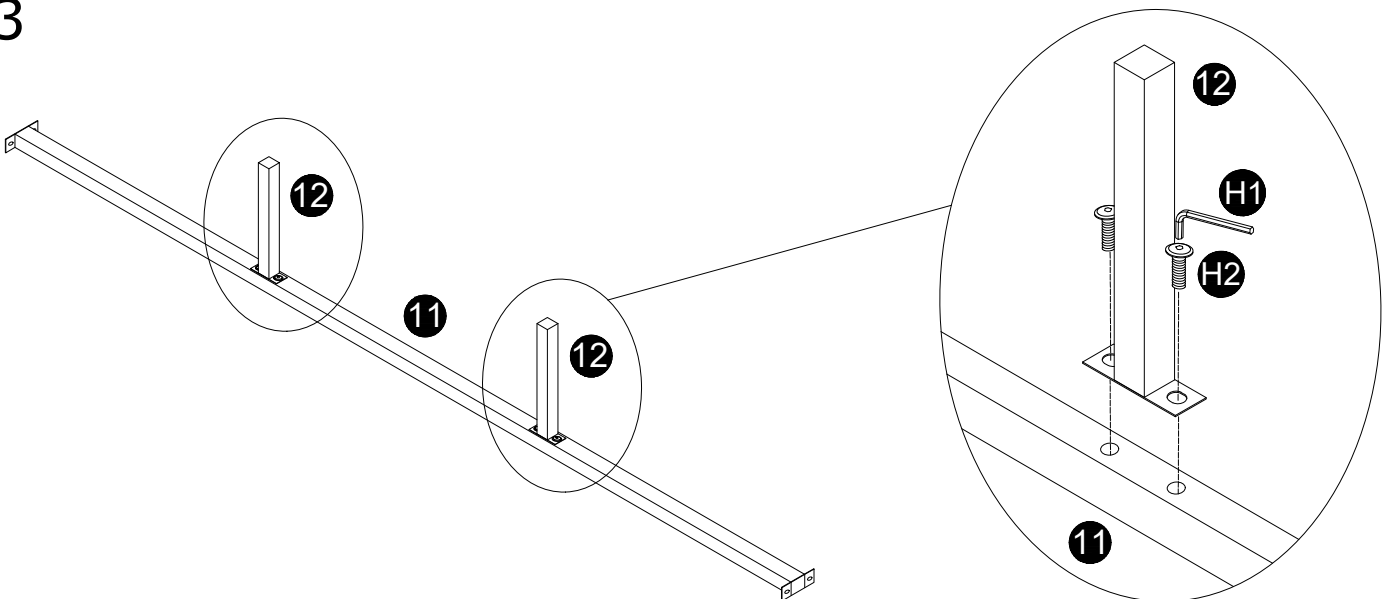

4

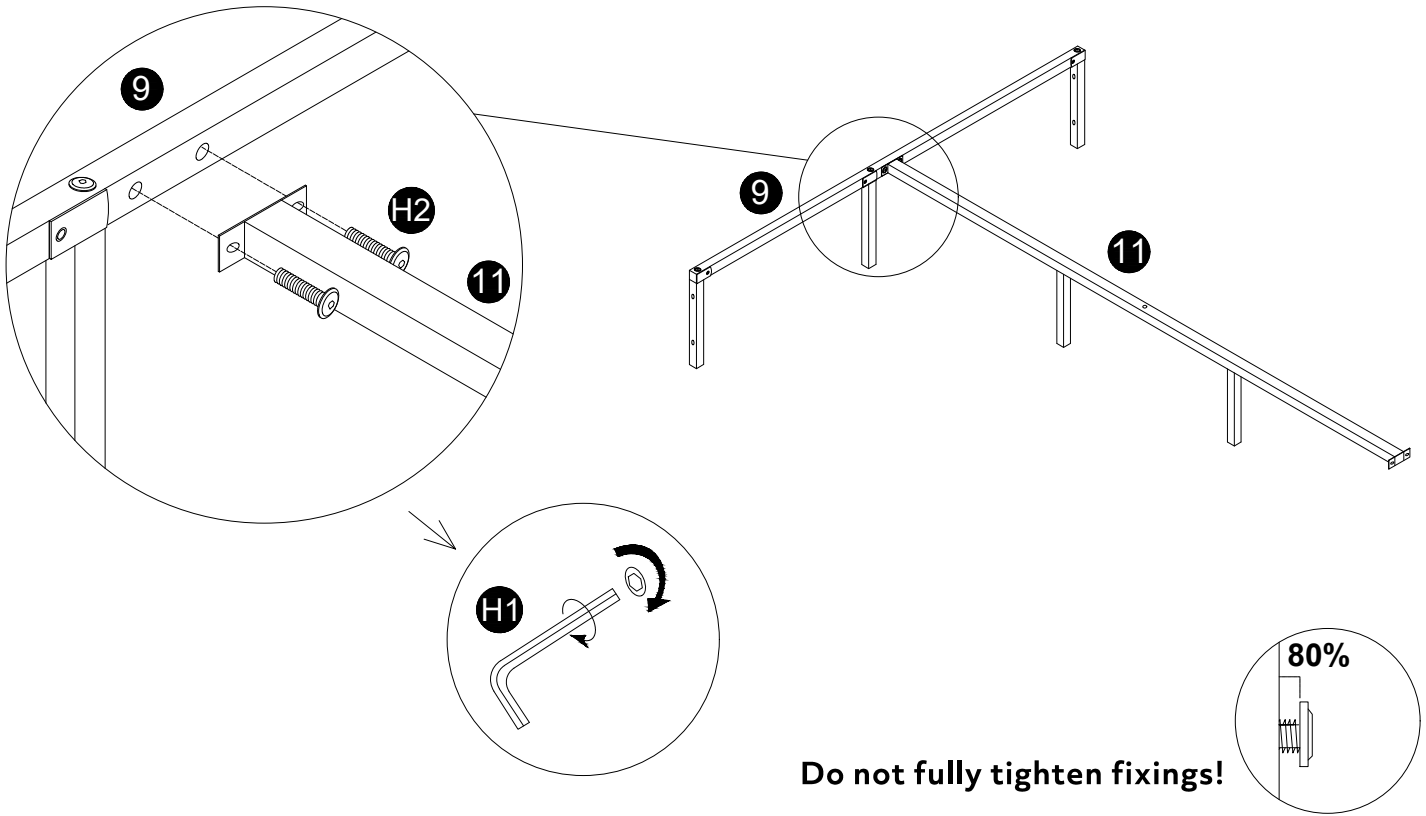

5

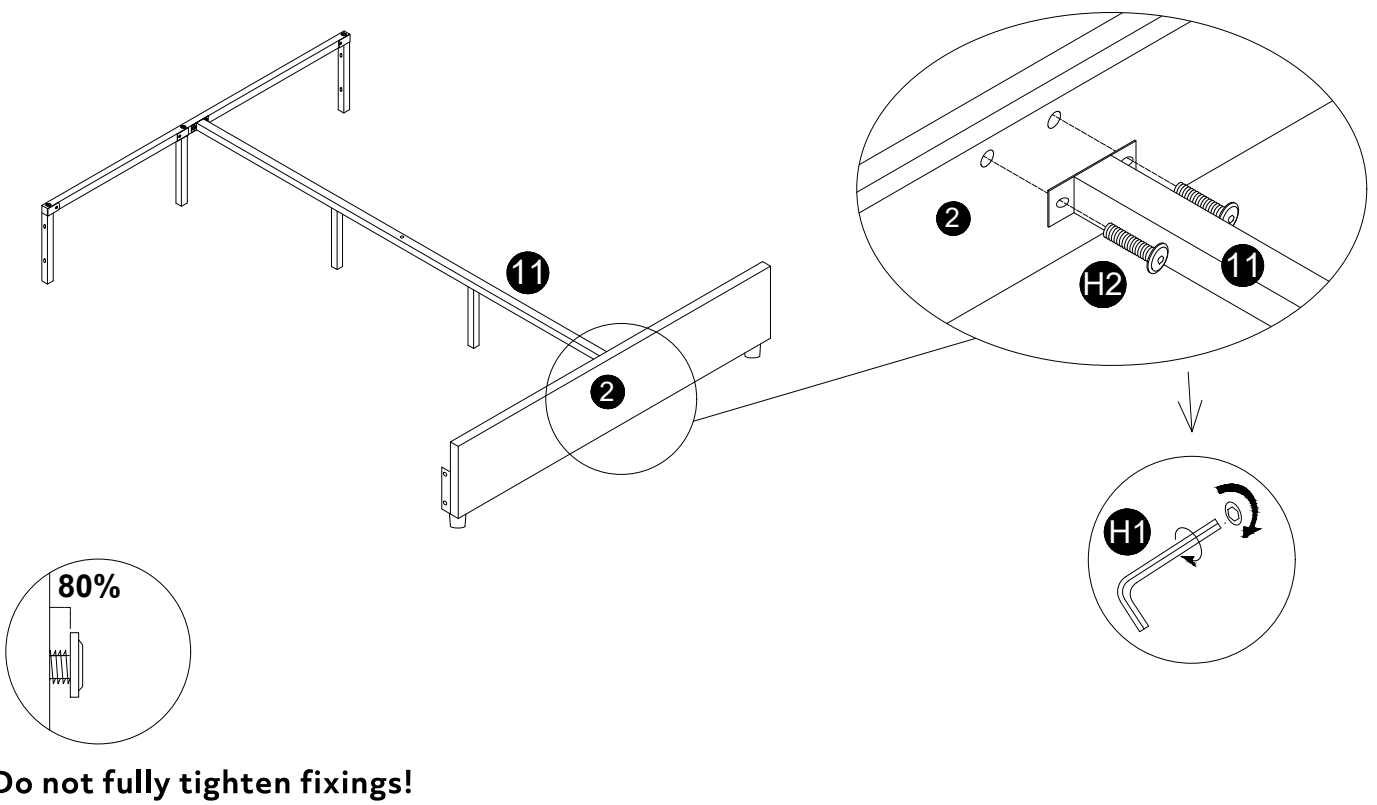

6

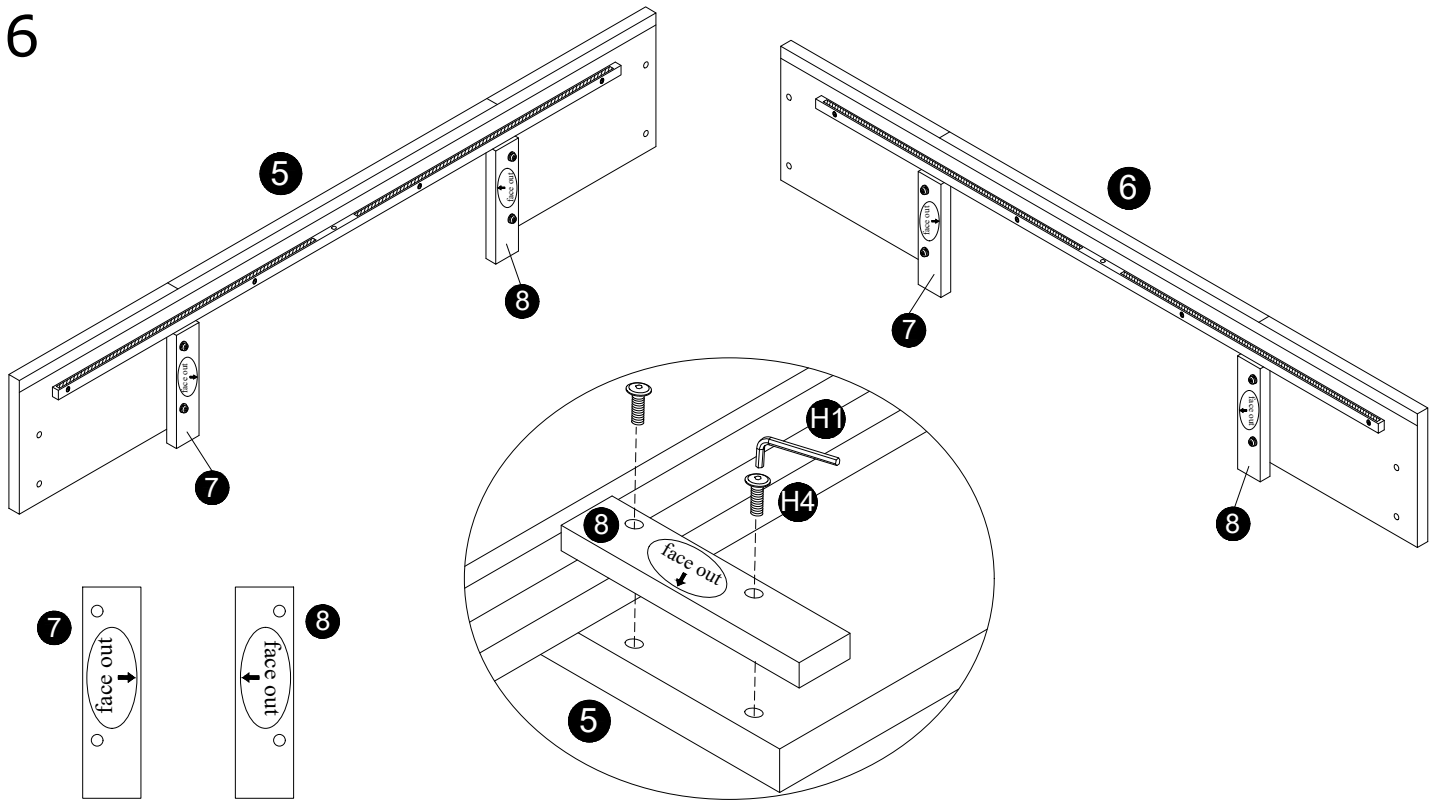

7

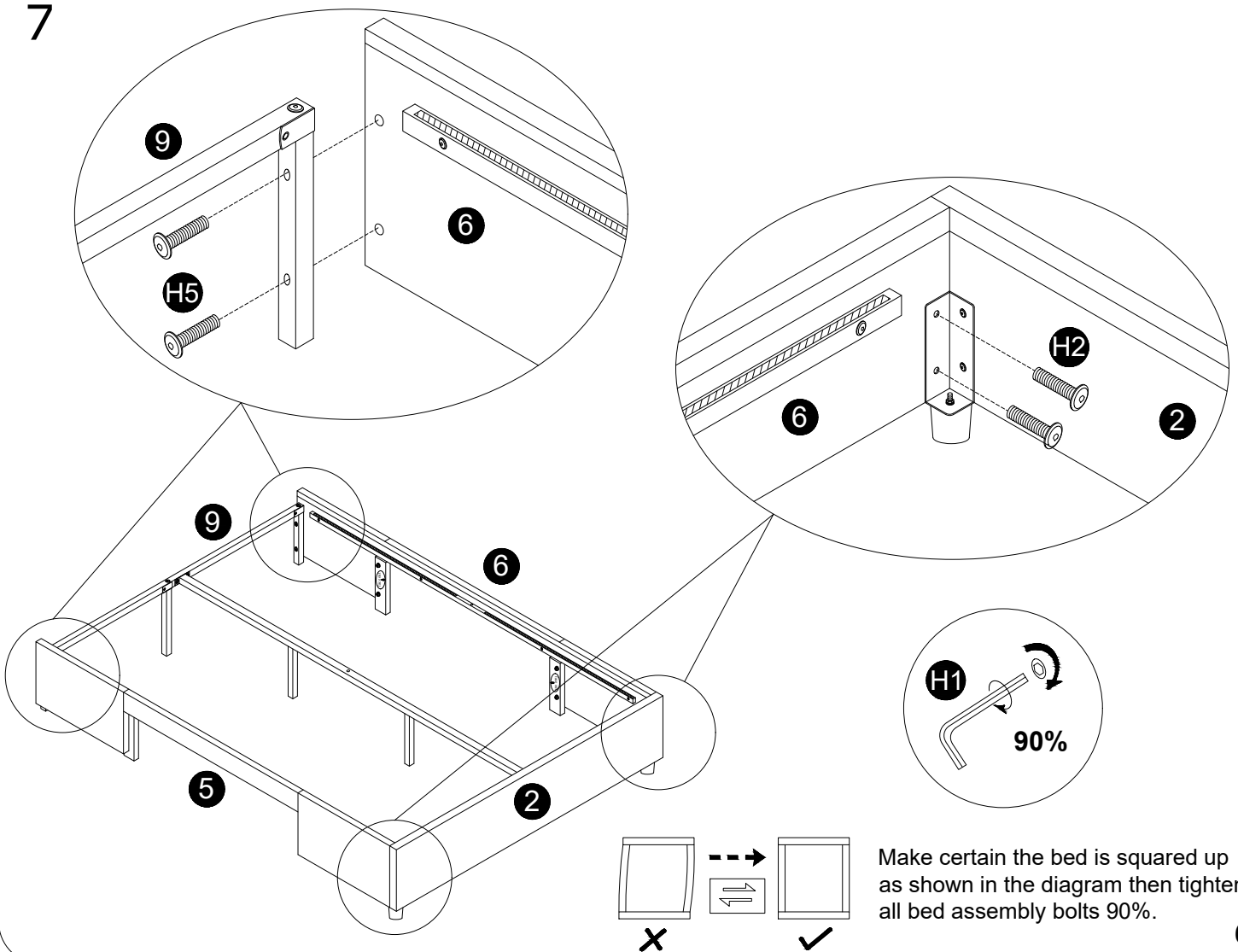

Make certain the bed is squared up as shown in the diagram then tighten all bed assembly bolts 90%.

8

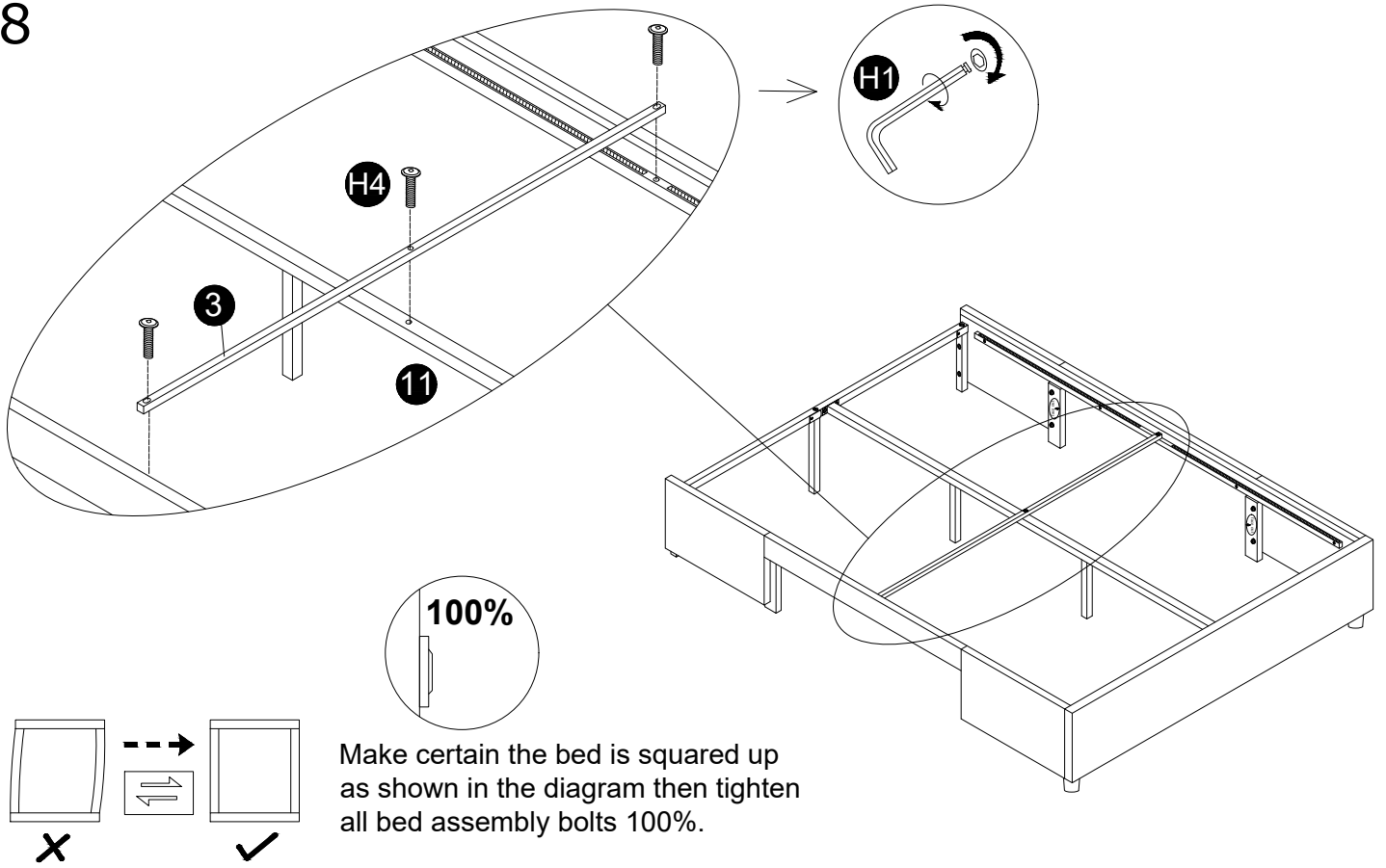

9

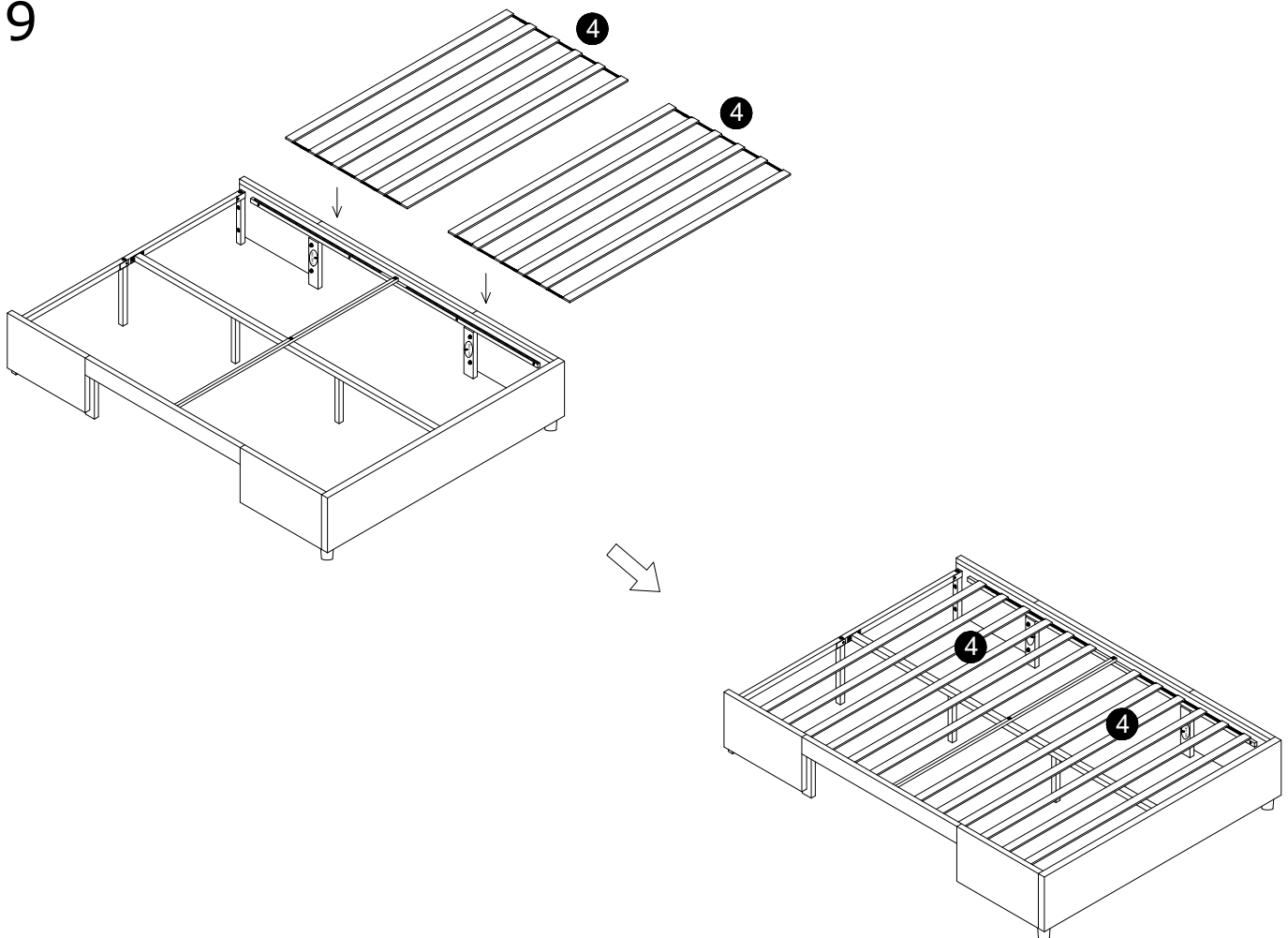

10

Grooves to align

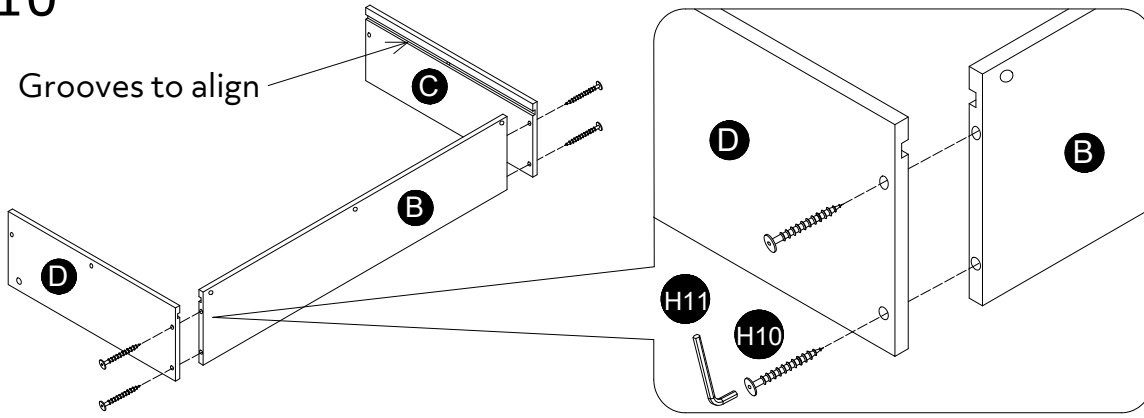

x2

11

a:

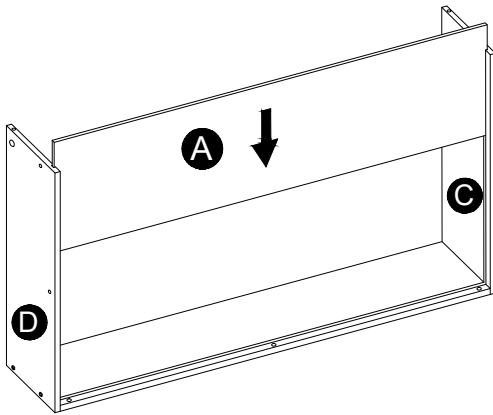

x2

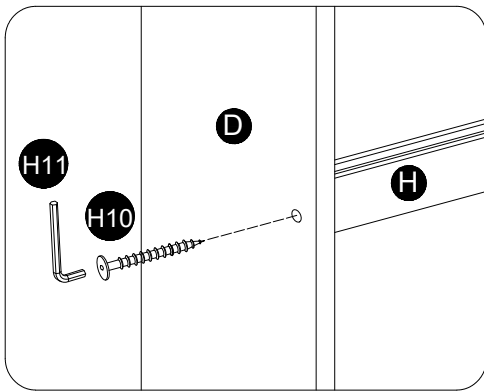

b:

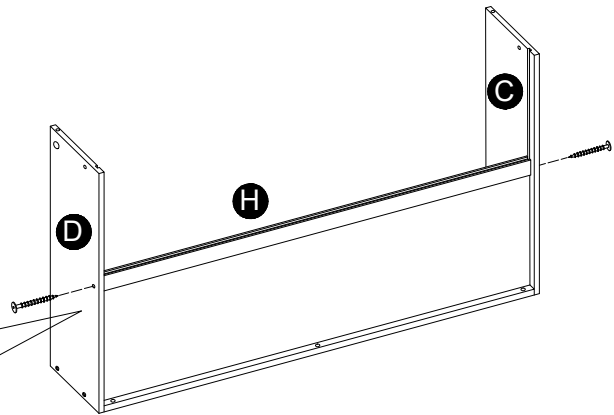

c:

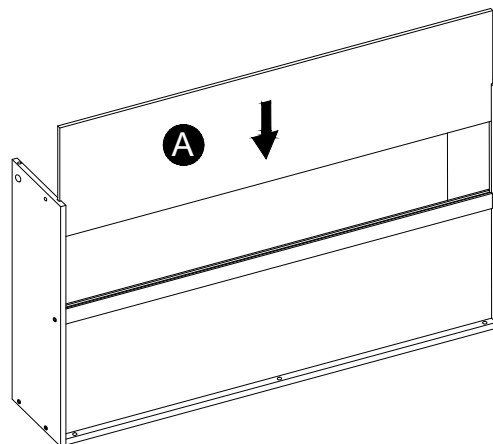

12

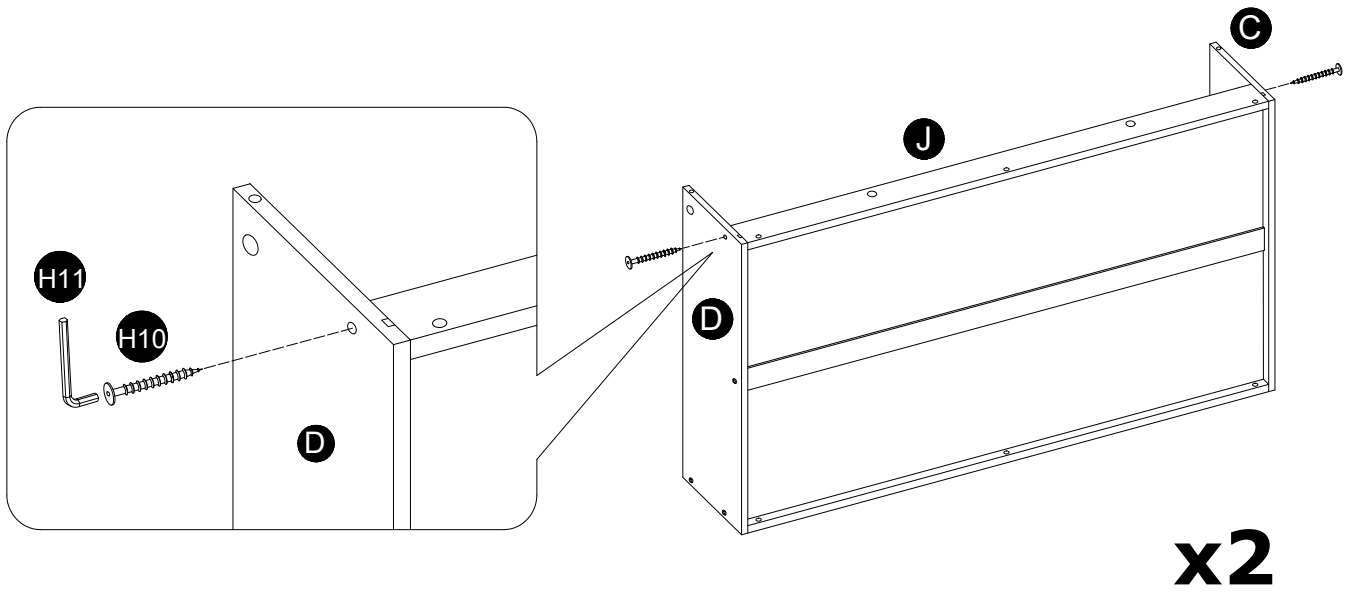

13

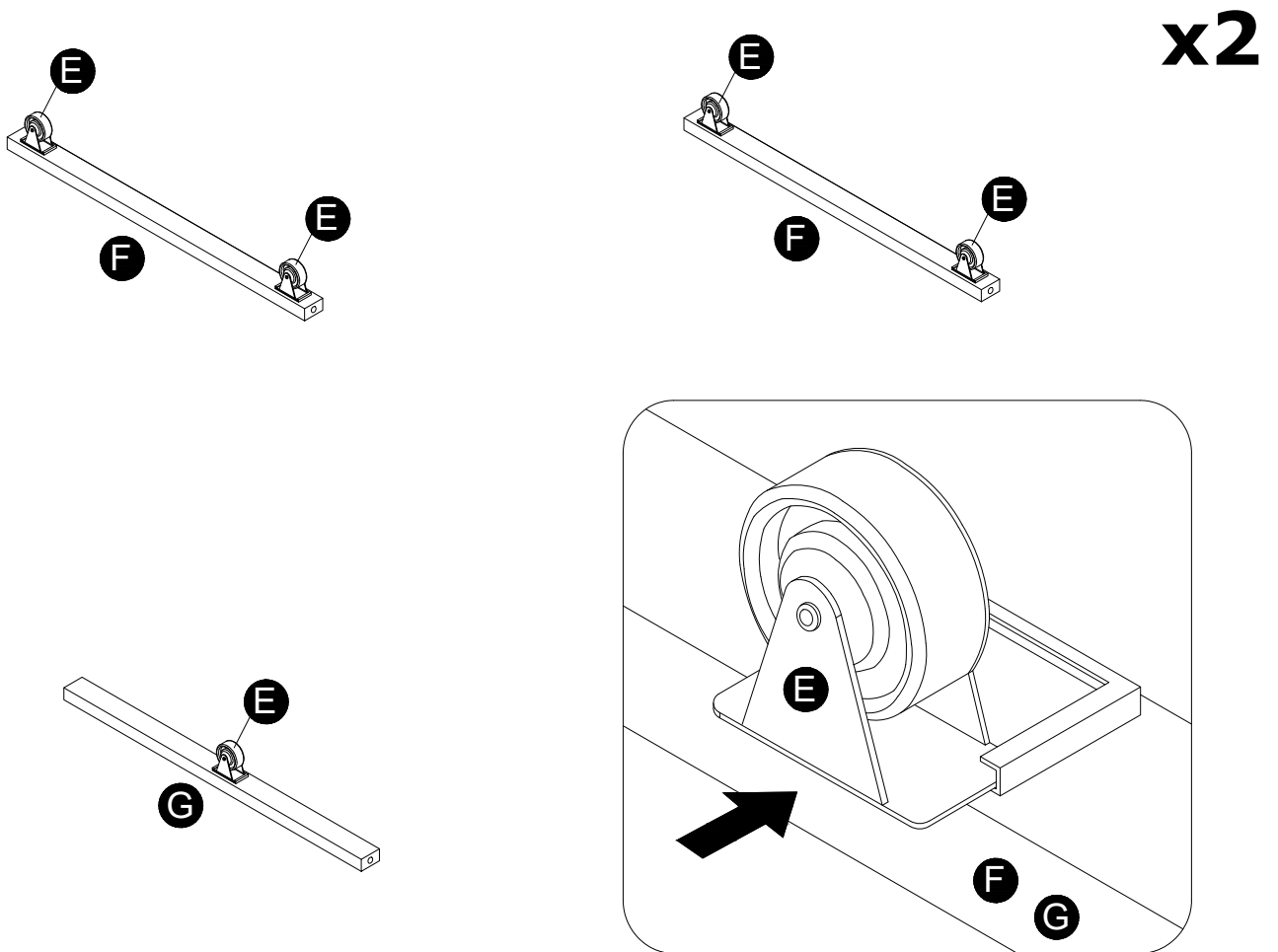

14 **x2**

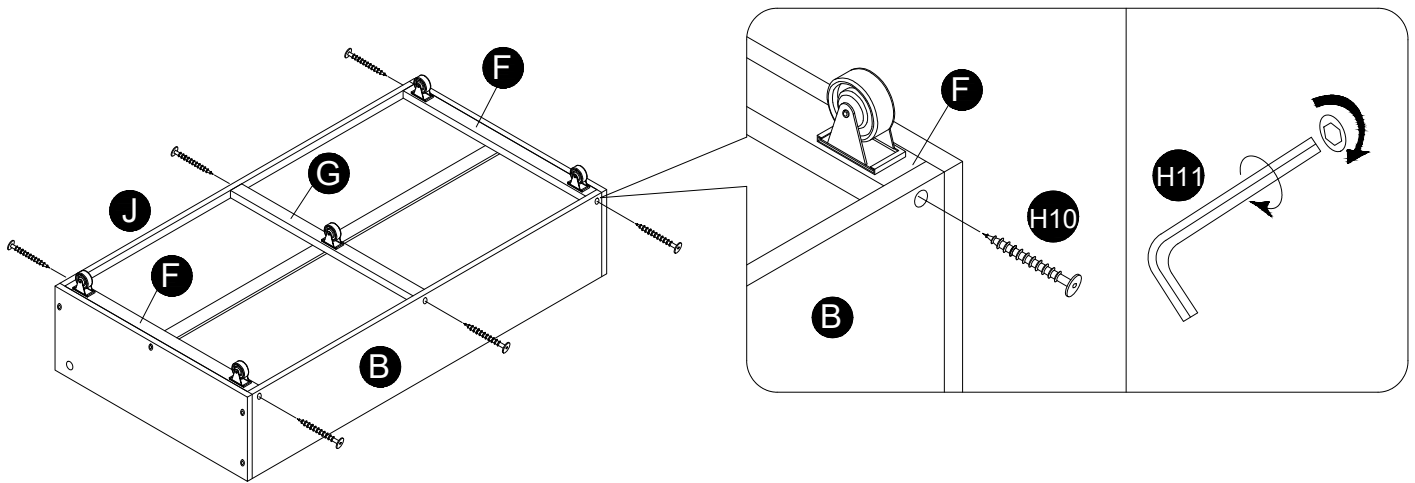

15 **x2**

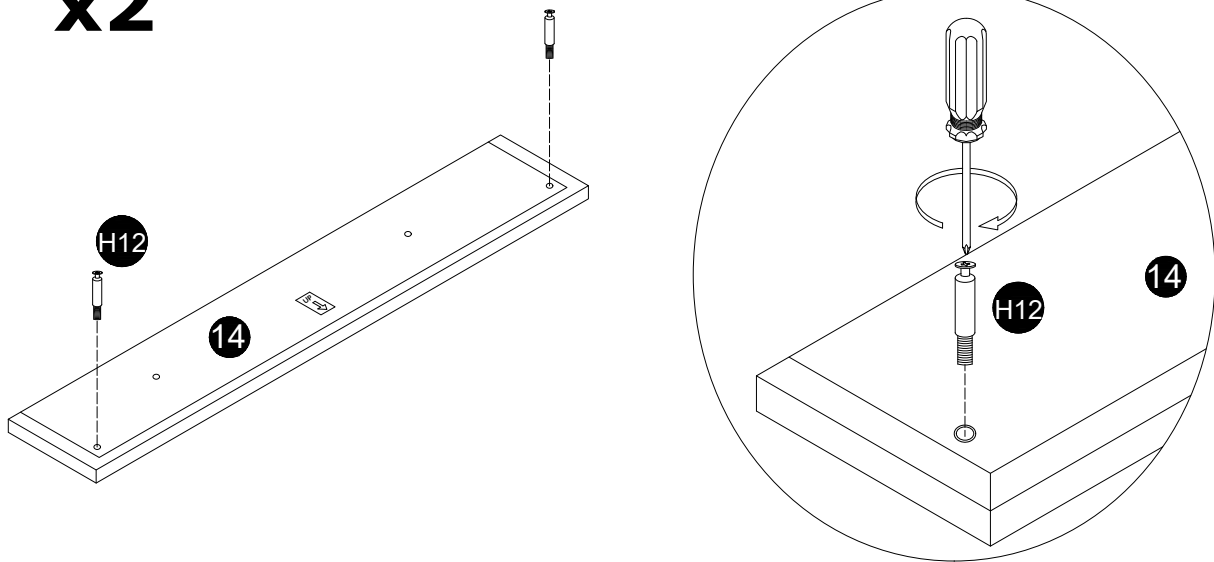

16 **x2**

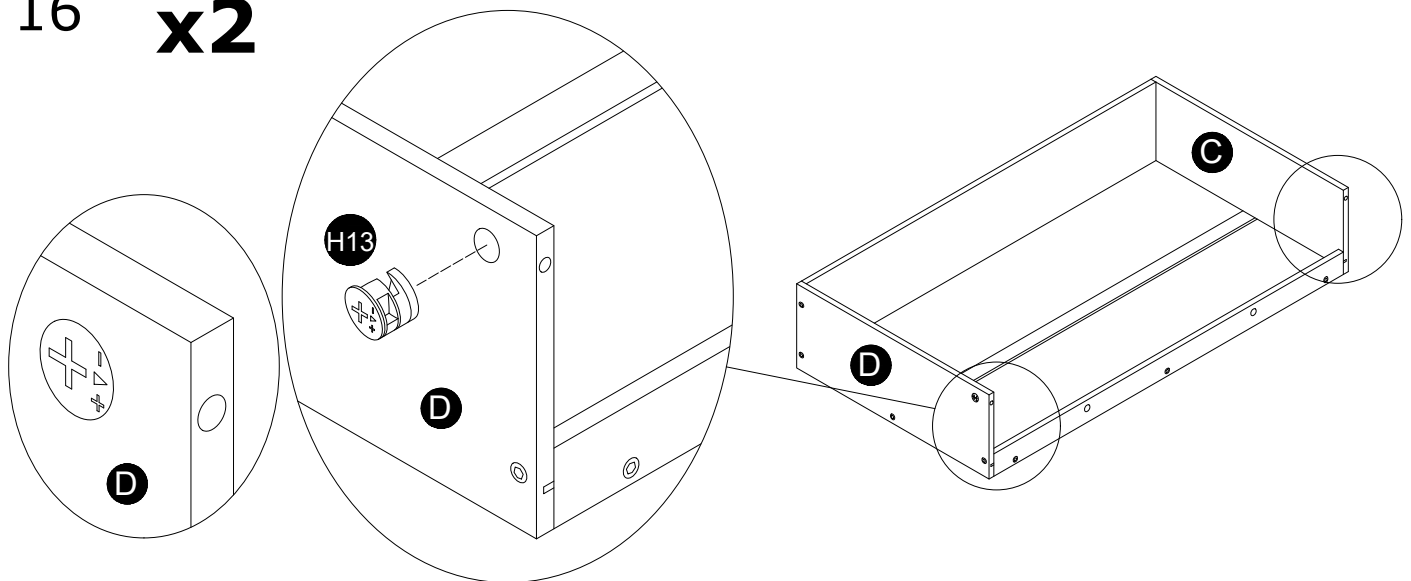

17 **x2**

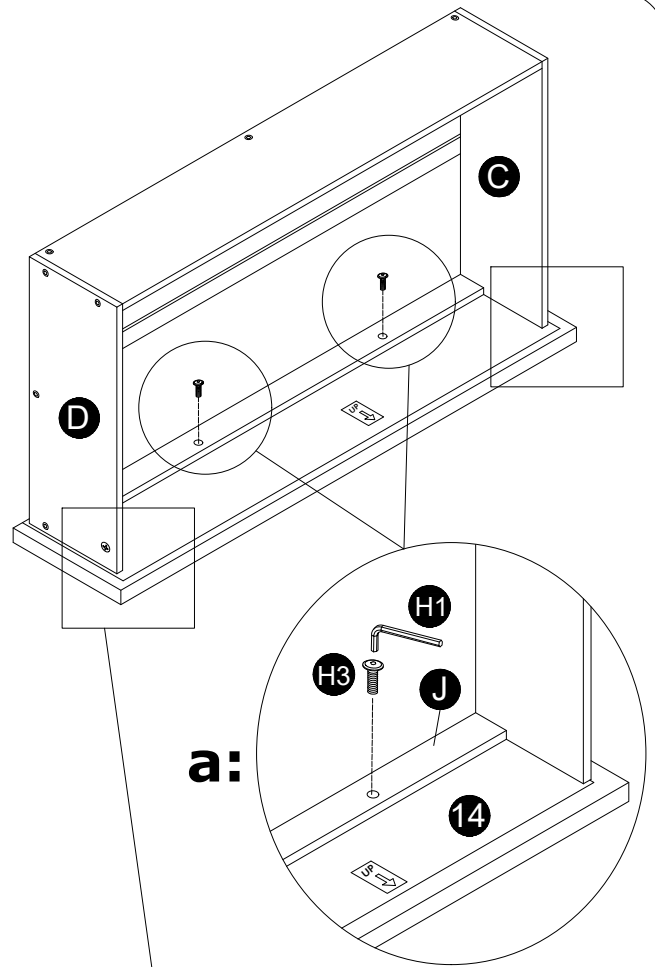
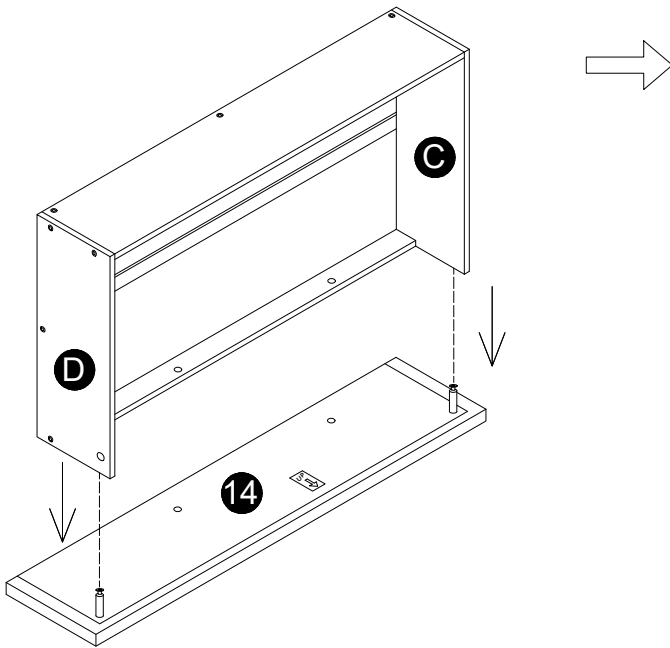

PUSH THE TWO PANELS TOGETHER ALLOWING THE DOWEL TO ALIGN WITH THE HOLE

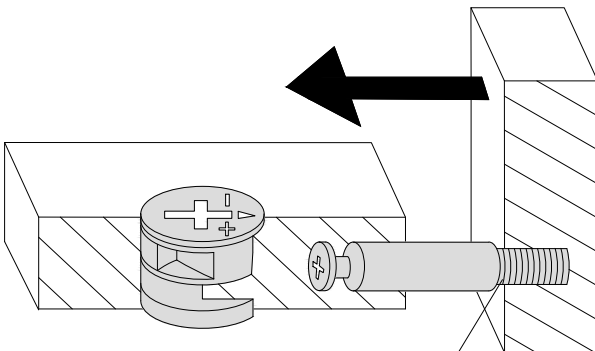

If H12 cannot lock into H13, you can adjust H12 outward by 2mm.

TURN THE CAM IN A CLOCKWISE DIRECTION

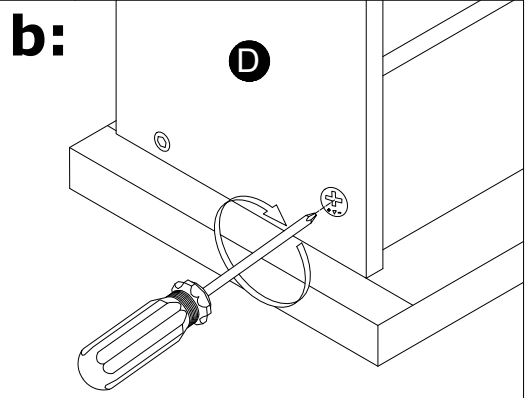
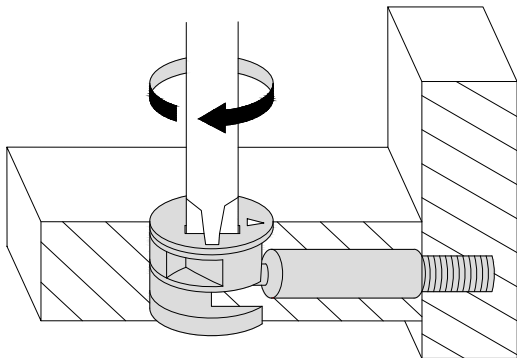

DON'T STOP UNTIL THE 2 O'CLOCK LOCK
TURN THE CAM IN A CLOCKWISE DIRECTION UNTIL THE ARROW POINTS IN THE POSITIONS SHOWN IN THE DIAGRAMS BELOW

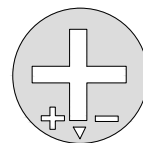

OPEN

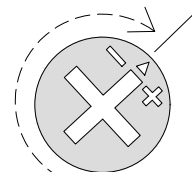

LOCKED

Job Complete !

In the interest of our environment please dispose of all packaging thoughtfully.