

## PATIO RECLINER CHAIR

---

If you have any questions about the Functional Recliner Kit, please feel free to contact us.

Customer Service Email: [Service@alaulm.com](mailto:Service@alaulm.com)

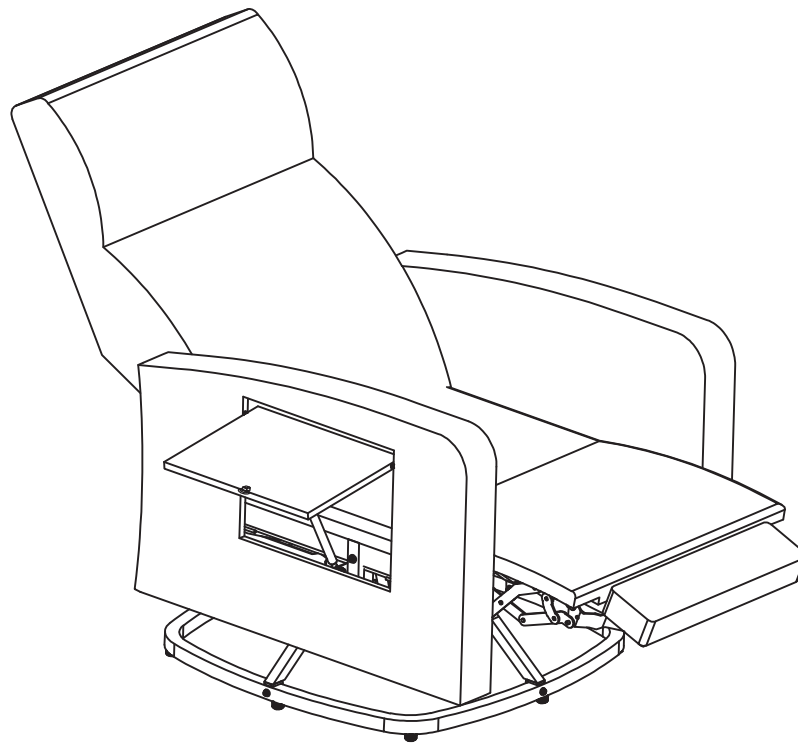

# P25068-D1

**IMPORTANT**

**PLEASE READ BEFORE YOU COMMENCE ASSEMBLY**

Follow the guidelines in this user guide to ensure correct assembly and care for this product.

# Catalog

Specifications..... 01

Catalog..... 02

Care & Instructions ..... 03

Part List And Screw Set List..... 04

Extra .....04

How to Use The PATIO RECLINER CHAIR .....06

# Before You Begin

## **Assembly Instructions:**

Instructions are supplied in this manual and contain all appropriate information for your building model.

Review all instructions before you begin and during assembly, follow the step sequence carefully for correct results.

## **Parts and Parts List:**

Check to be sure that you have all the necessary parts for building.

Separate contents of the carton by the part number while reviewing parts list.

Familiarize yourself with the hardware and fasteners for easier use during construction.

The first few steps show how to join related parts which is to obtain larger sub-assemblies be used later.

All parts are packaged within the carton.

Note that extra fasteners have been supplied for your convenience.

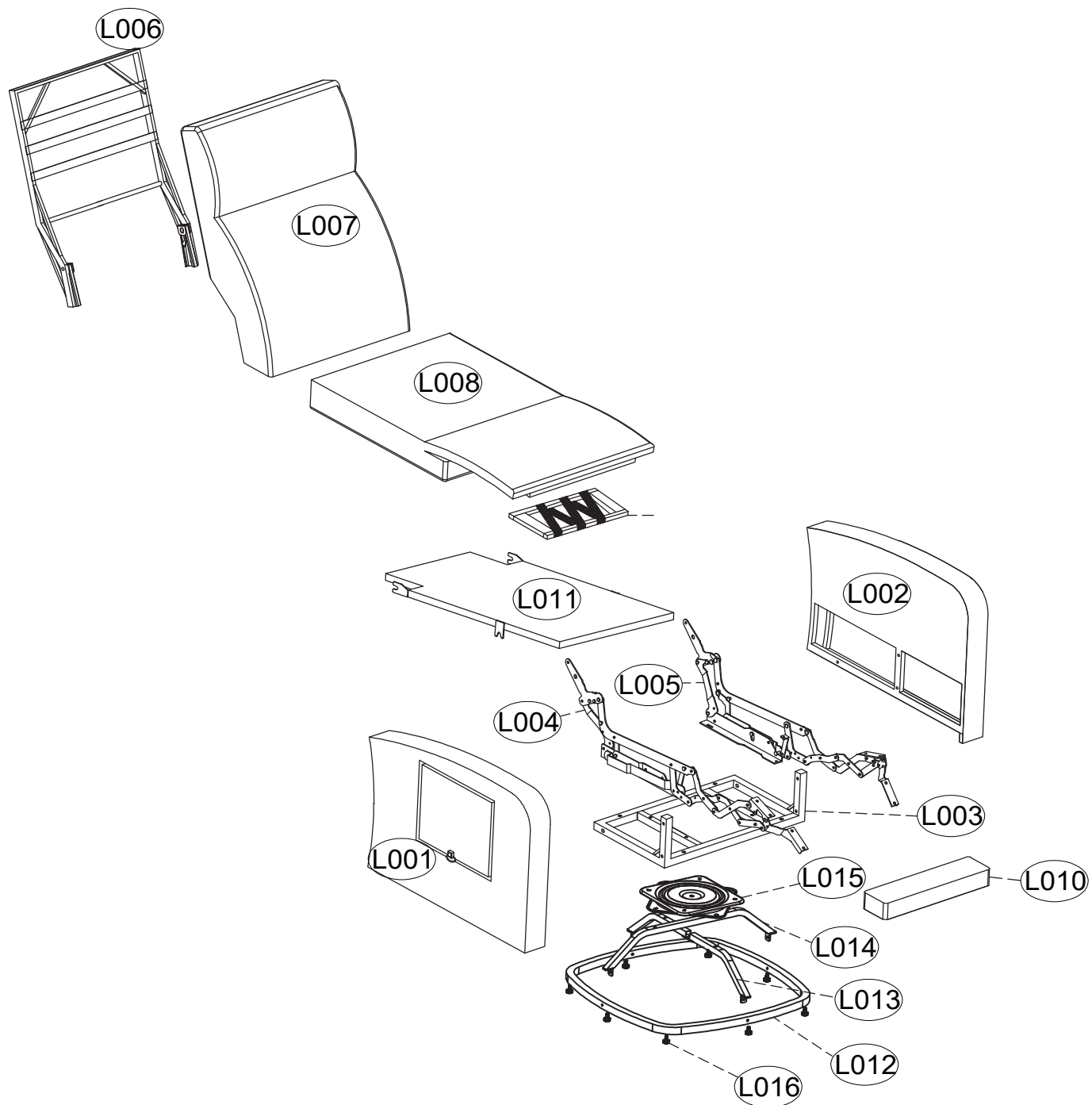

## How to assemble a recline

Illustration of the installation position of each component





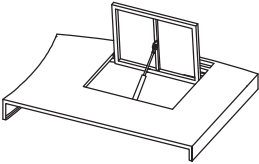
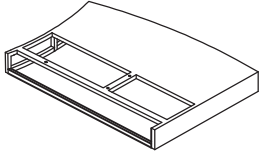
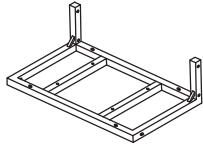
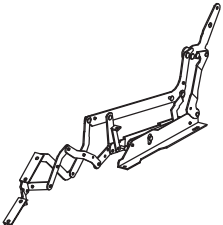
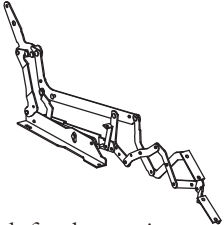
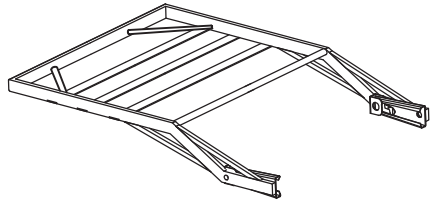
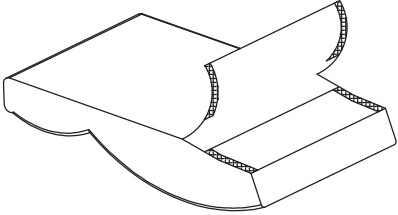
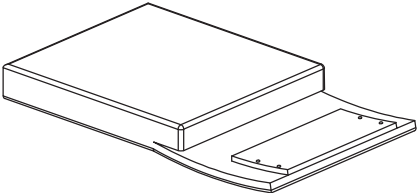

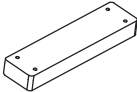
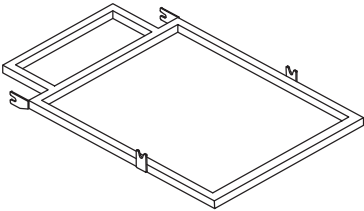
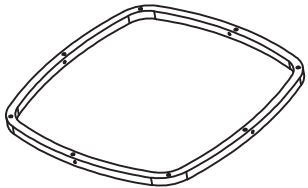
# PART LIST

## Parts List



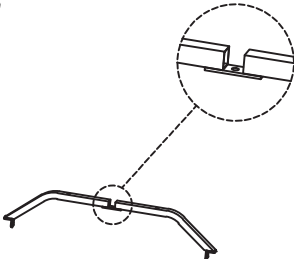



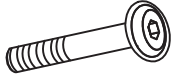

<p>(L001)</p>  <p>right handrail</p>	<p>(L002)</p>  <p>left handrail</p>	<p>(L003)</p>  <p>rackmount</p>
<p>1 PC</p>	<p>1 PC</p>	<p>1 PC</p>
<p>(L004)</p>  <p>Right telescopic arm</p>	<p>(L005)</p>  <p>left telescopic arm</p>	<p>(L006)</p>  <p>Backrest Support Frame</p>
<p>1 PC</p>	<p>1 PC</p>	<p>1 PC</p>
<p>(L007)</p>  <p>Back Cushion</p>	<p>(L008)</p>  <p>Seat Cushion</p>	<p>(L009)</p>  <p>connection</p>
<p>1 PC</p>	<p>1 PC</p>	<p>1 PC</p>
<p>(L010)</p>  <p>footrest</p>	<p>(L011)</p>  <p>Cushion holder</p>	<p>(L012)</p>  <p>foundation</p>
<p>1 PC</p>	<p>1 PC</p>	<p>1 PC</p>

# PART LIST

## Parts List

<p>(L013)</p>  <p>chair leg</p>	<p>(L014)</p>  <p>chair leg</p>	<p>(L015)</p>  <p>disk shaft</p>
<p>1 PC</p>	<p>1 PC</p>	<p>1 PC</p>
<p>(L016)</p>  <p>adjustable feet</p>		
<p>8 PCS</p>		

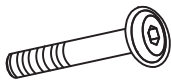
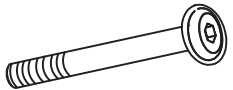
# PART LIST

Screw Set A List		
<p>(A)</p>  <p>M6*15mm</p>	<p>(B)</p>  <p>M6*35mm</p>	<p>(C)</p>  <p>M6*50mm</p>
9 PCS	16 PC	6 PC
<p>(D)</p>  <p>M6mm</p>	<p>(E)</p>  <p>Allen Key(M6mm)</p>	<p>(F)</p>  <p>Wrench(M6)</p>
22 PC	1 PC	1 PC
Extra (Screw Set A)		
<p>(A)</p>  <p>M6*15mm</p>	<p>(B)</p>  <p>M6*35mm</p>	<p>(C)</p>  <p>M6*50mm</p>
1 PC	2 PCS	1 PC
<p>(D)</p>  <p>M6mm</p>		
2 PCS		

# SPECIFICATIONS

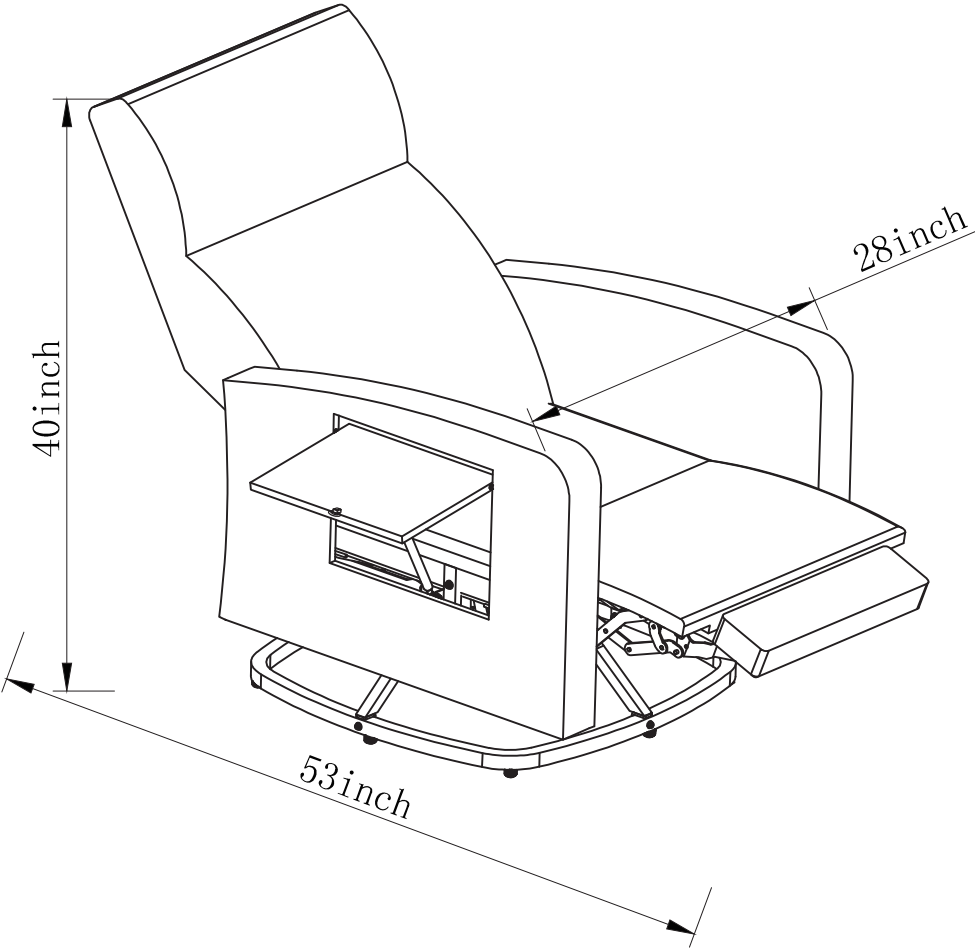

## How to assemble a recline

**Step 1:** Connect the adjusting foot (L016) to the base (L012)

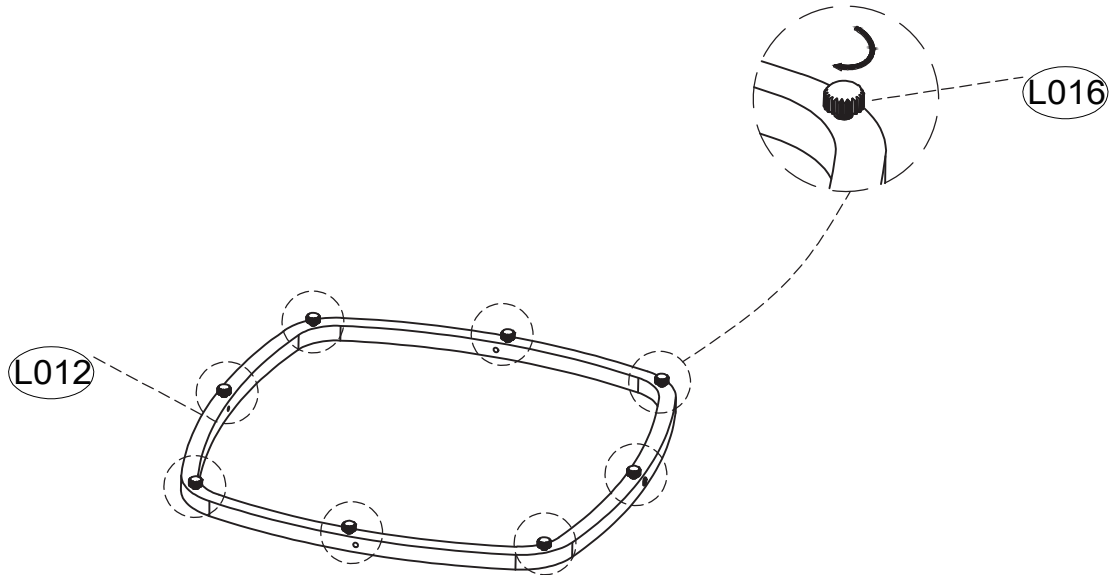

L012

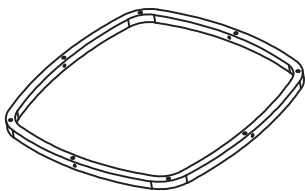

x1

L016



x8

**Step 2:** Attach the chair legs (L013) and chair feet (L014) with screws (A)  
**NOTE:** Do not tighten the screws all the way.

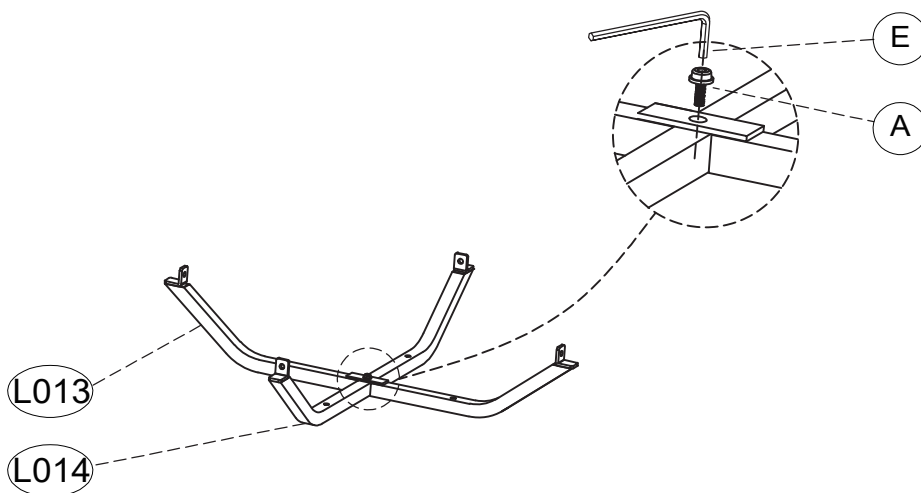

L013

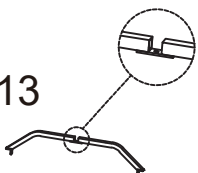

x1

L014



x1

E



x1

Allen Key(M6mm)

A



x1

M6\*15mm

## How to assemble a recline

**Step 3:** Attach the base (L012) and chair legs (L013, L014) with screws (B) and nuts (D).

**NOTE:** Do not tighten the screws all the way.

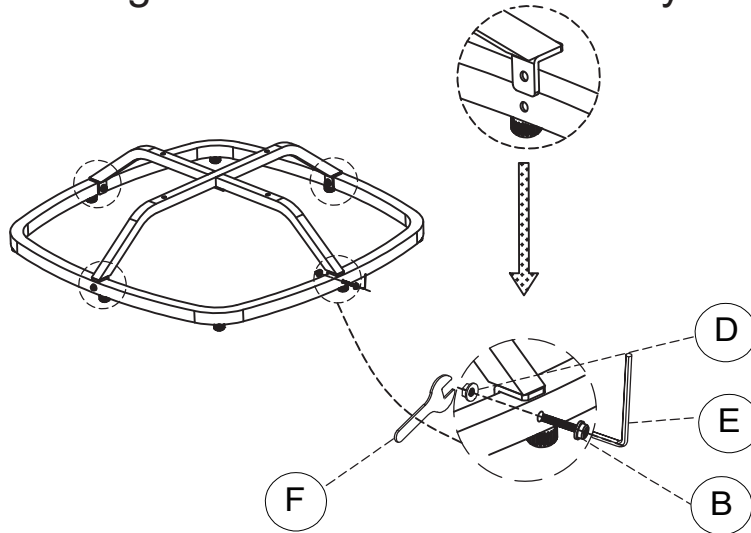

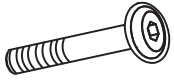
B  x4  
M6\*35mm

D  x4  
M6mm

E  x1  
Allen Key(M6mm)

F  x1  
Wrench(M6)

**Step 4:** Attach chair legs (L013, L014) and disc shaft (L015) with screws (B) and nuts (D)

**NOTE:** Do not tighten the screws all the way.

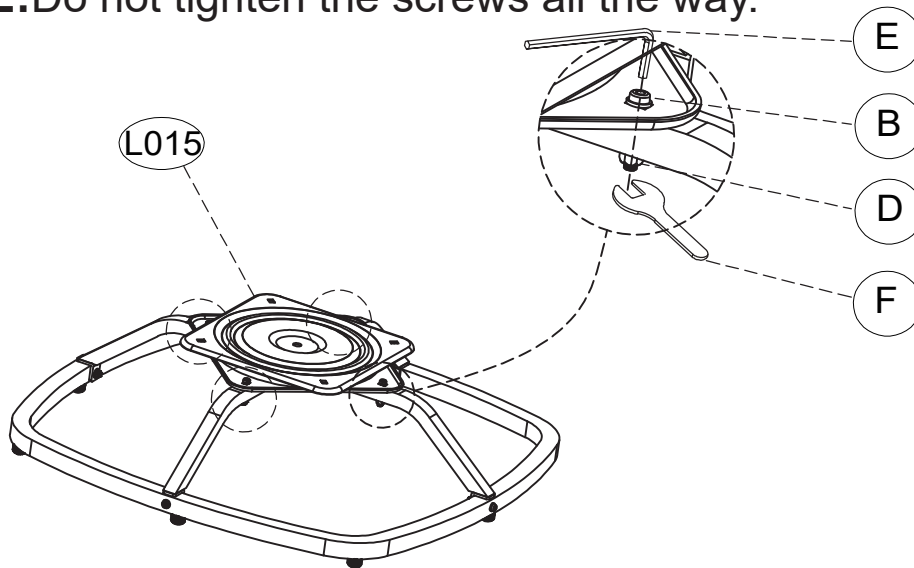

L015  x1

B  x4  
M6\*35mm

E  x1  
Allen Key(M6mm)

D  x4  
M6mm





F  x1  
Wrench(M6)

## How to assemble a recline

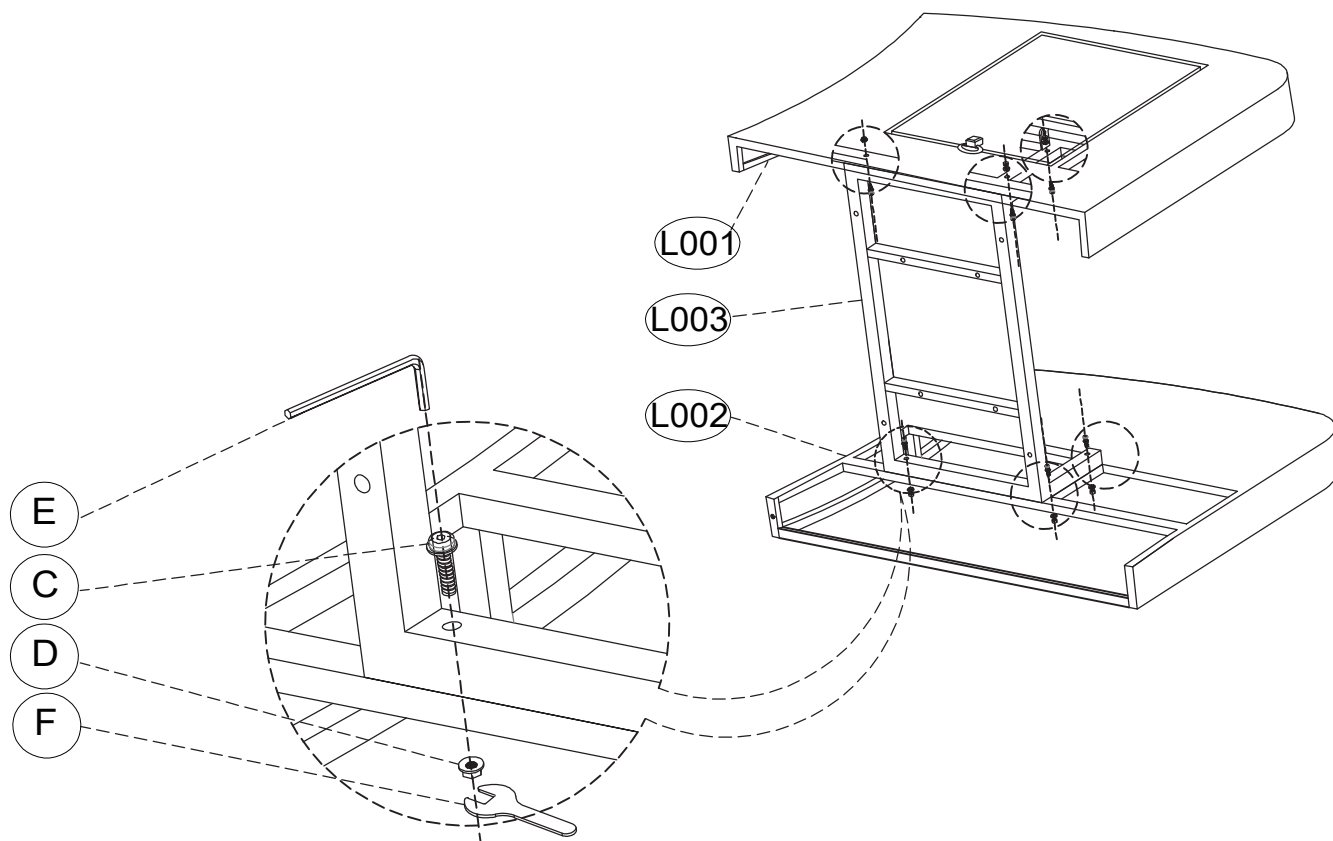
**Step 5:** Connect the left armrest (L002) and right armrest (L001) to the frame (L003) with screws (C) and nuts (D)

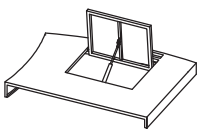
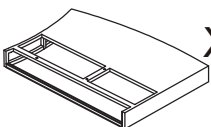
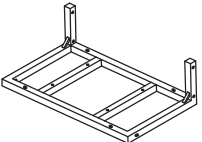
**NOTE:** Do not tighten the screws all the way.



L001  X1	L002  X1	L003  X1	C  X6 M6*50mm
D  X6 M6mm	E  X1 Allen Key(M6mm)	F  X1 Wrench(M6)	

### How to assemble a recline

**Step6 :**

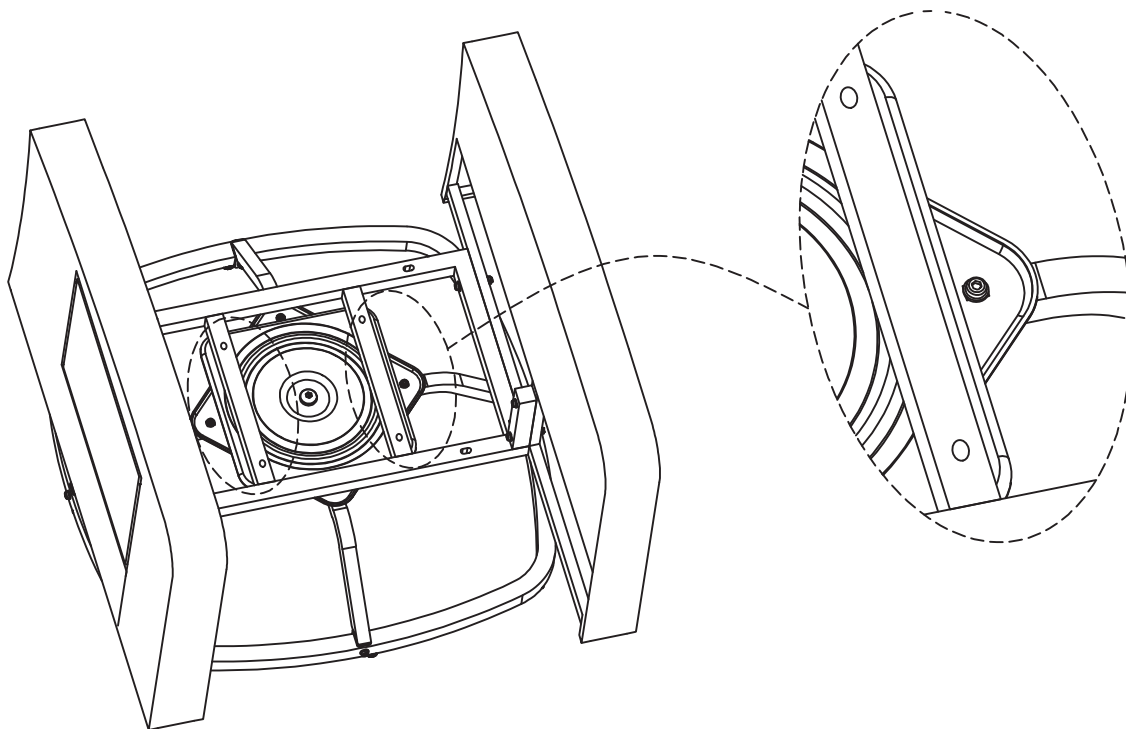

**1:Place the rack on the chassis**

**2:Rotate it to the appropriate position before proceeding with the next installation step**

## How to assemble a recline

**Step7 :** Connect the base (L012) to the frame (L003) via the disk shaft (L015) with screws (B) and nuts (D)

**NOTE:** Do not tighten the screws all the way.

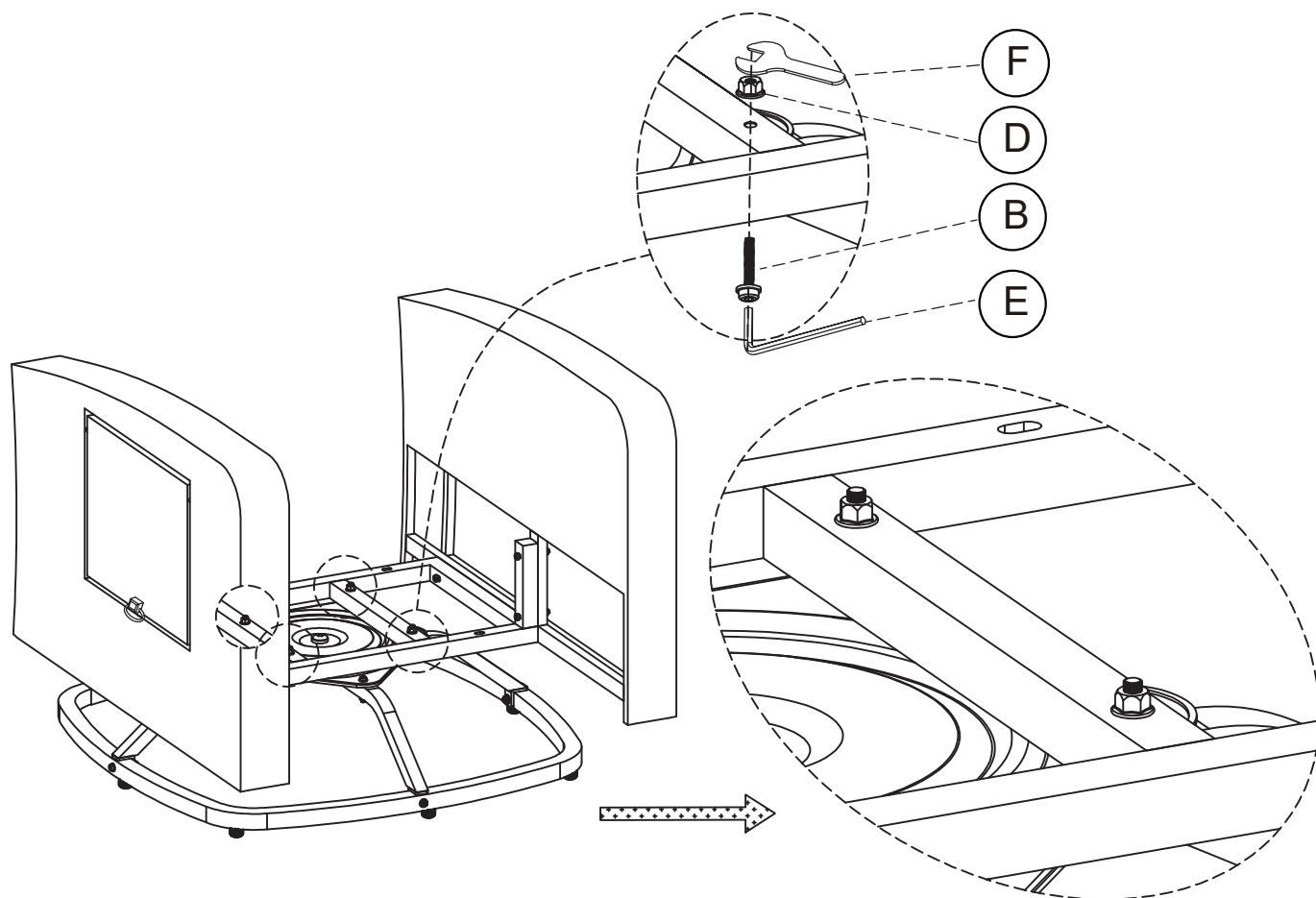

F  X1  
Wrench(M6)

D  X4  
M6mm

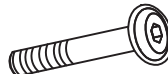



B  X4  
M6\*35mm

E  X1  
Allen Key(M6mm)

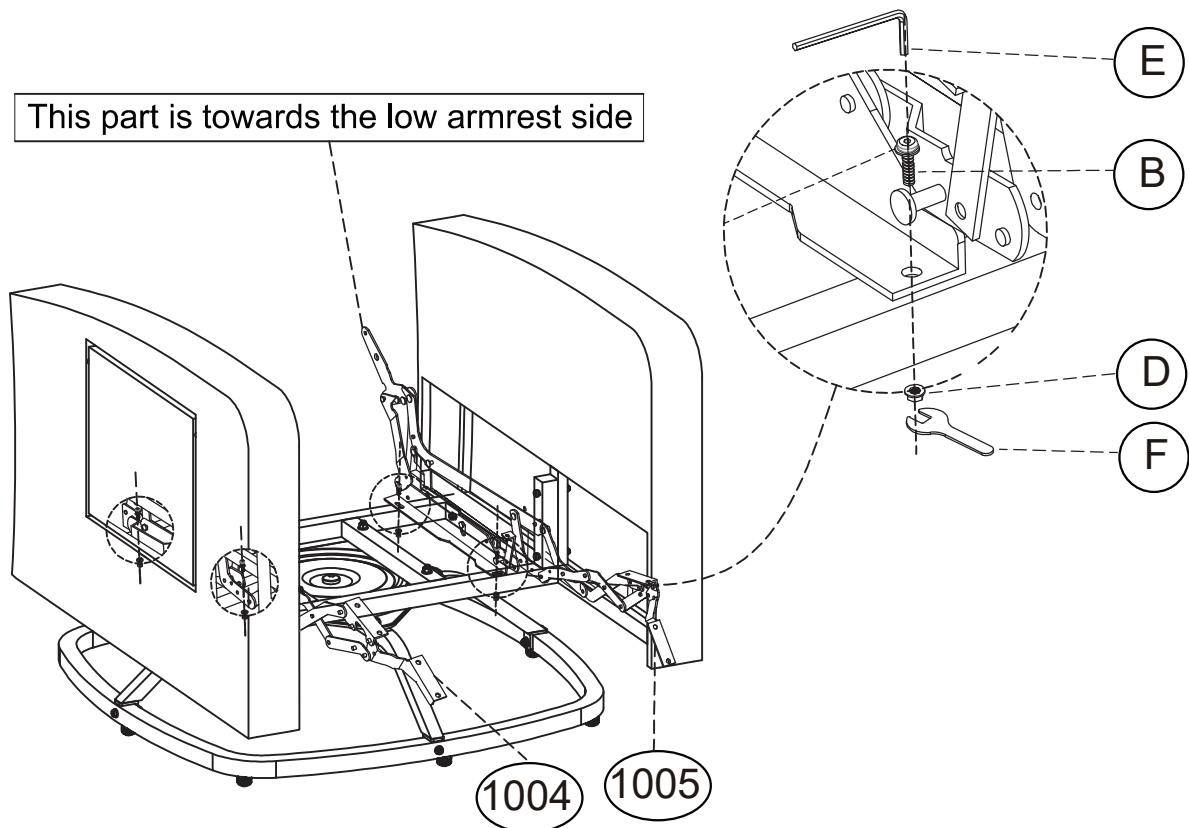
## How to assemble a recline

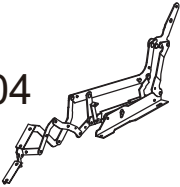
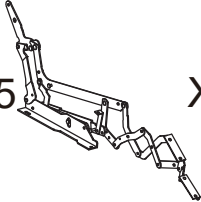
**Step8 :** Connect the telescopic arms (L004, L005) and the frame (L003) with screws (B) and nuts (D).

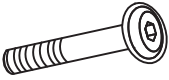

<p>1004 X1</p> 	<p>1005 X1</p> 	<p>E X1</p>  <p>Allen Key(M6mm)</p>	<p>B X4</p>  <p>M6*35mm</p>
<p>D X4</p>  <p>M6mm</p>	<p>F X1</p>  <p>Wrench(M6)</p>		

## How to assemble a recline

**Step9** : Install the cushion brackets (L011) onto the front and rear telescoping arms (L004, L005).

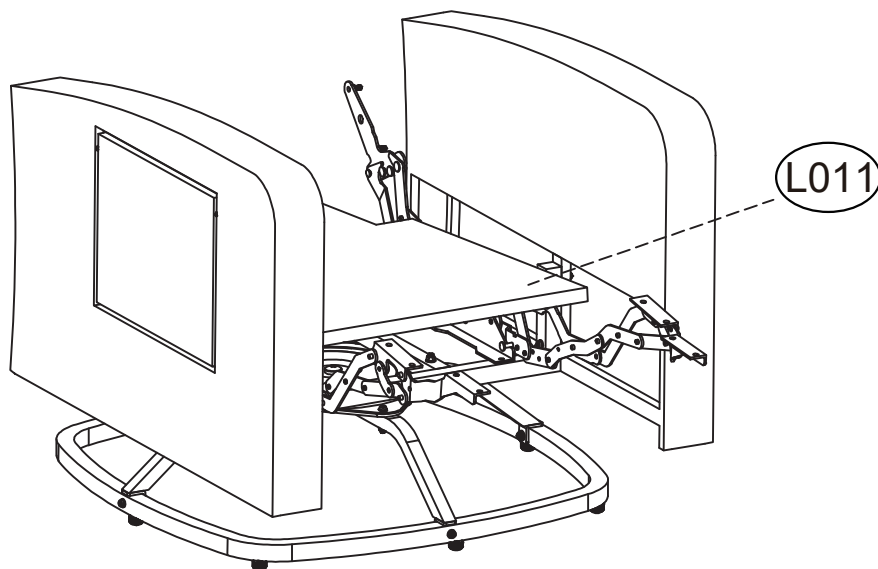

### Assembly diagram breakdown

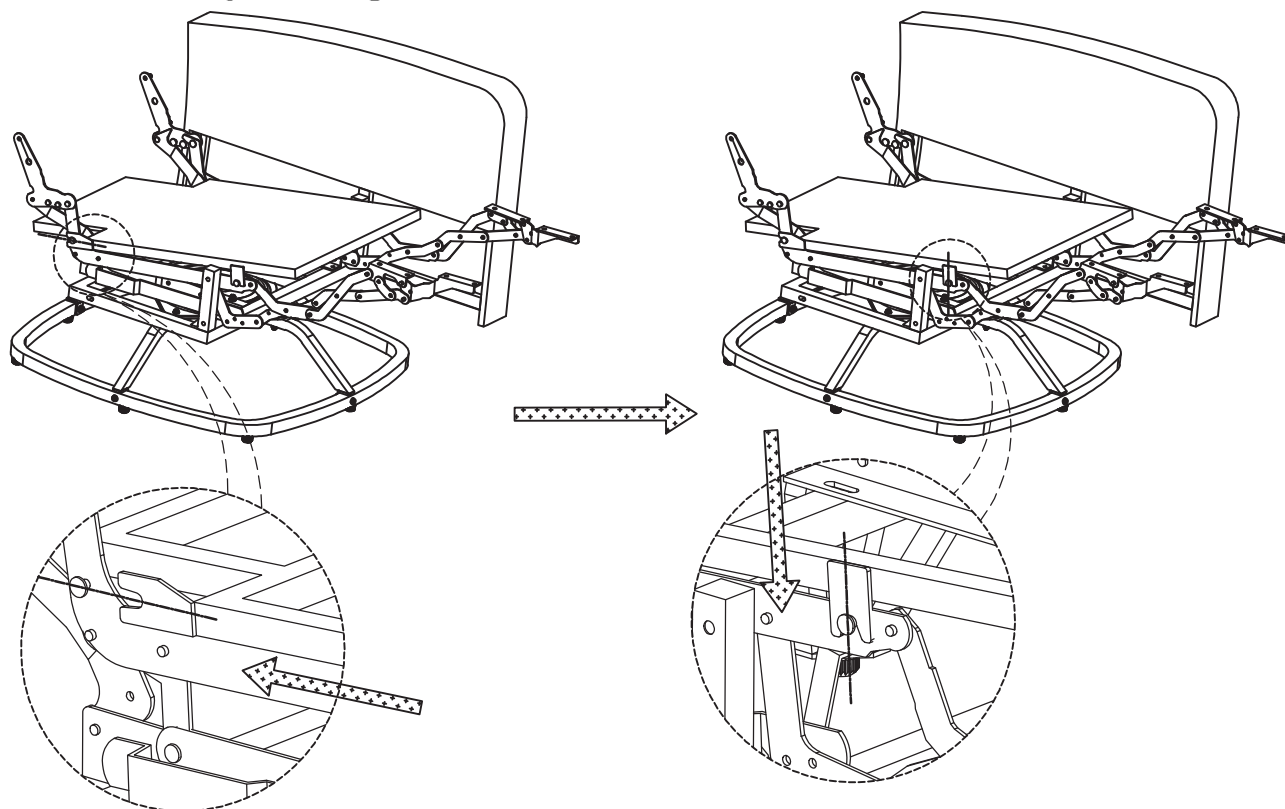

1011

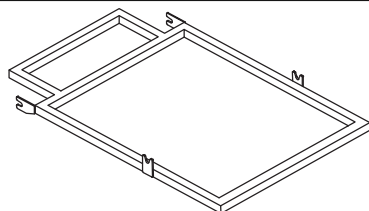

X1

## How to assemble a recline

**Step10** : Fit the connector (L009) inside the cushion (L008) and secure.

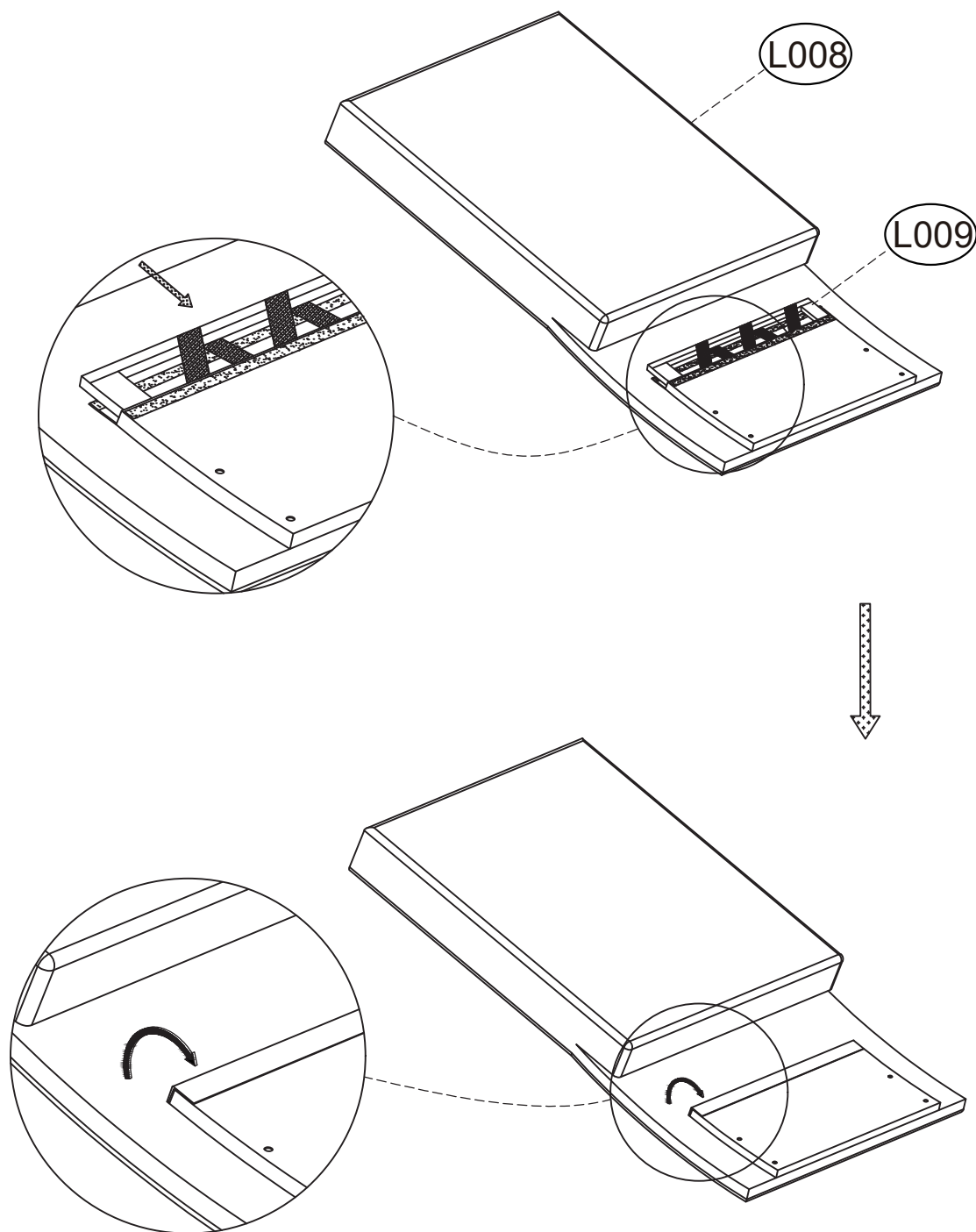

1008

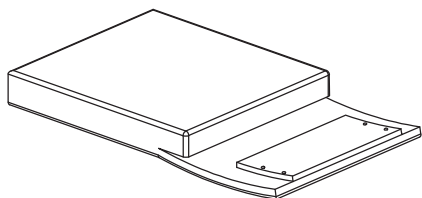

X1

1009



X1

## How to assemble a recline

**Step11** : Attach the Cushion (L008) and the Telescopic Arm (L004, L005) with the screws (A)

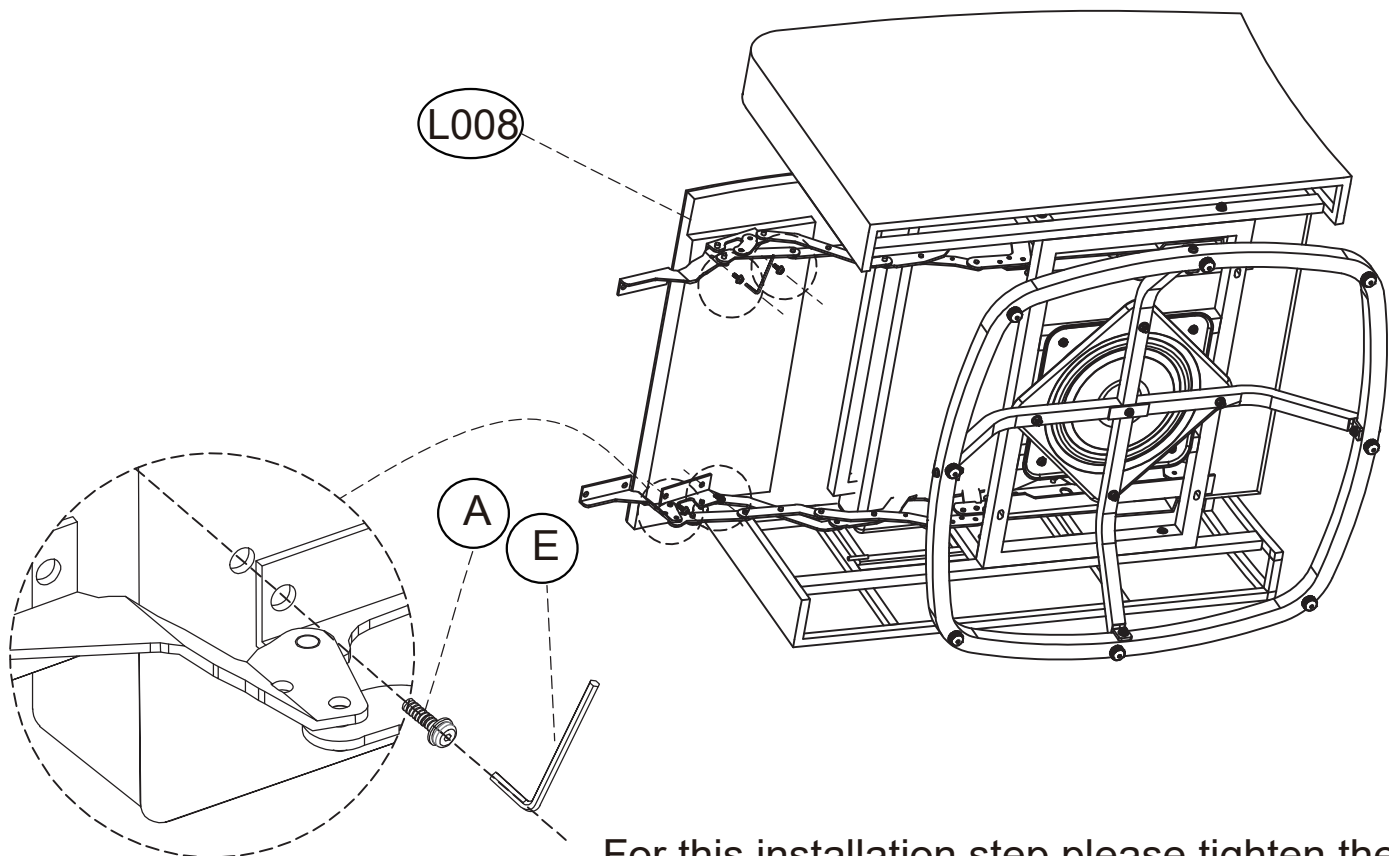

For this installation step, please tighten the screws to 100%

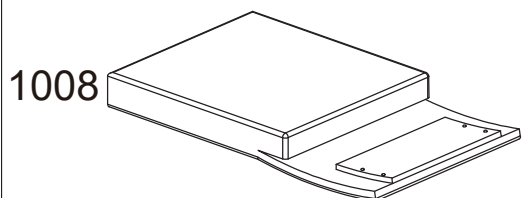

1008

X1

A



M6\*15mm

X4

E



Allen Key(M6mm)

X1

## How to assemble a recline

**Step12** : Attach the footrest (L010) and telescopic arm (L004, L005) with screws (A)

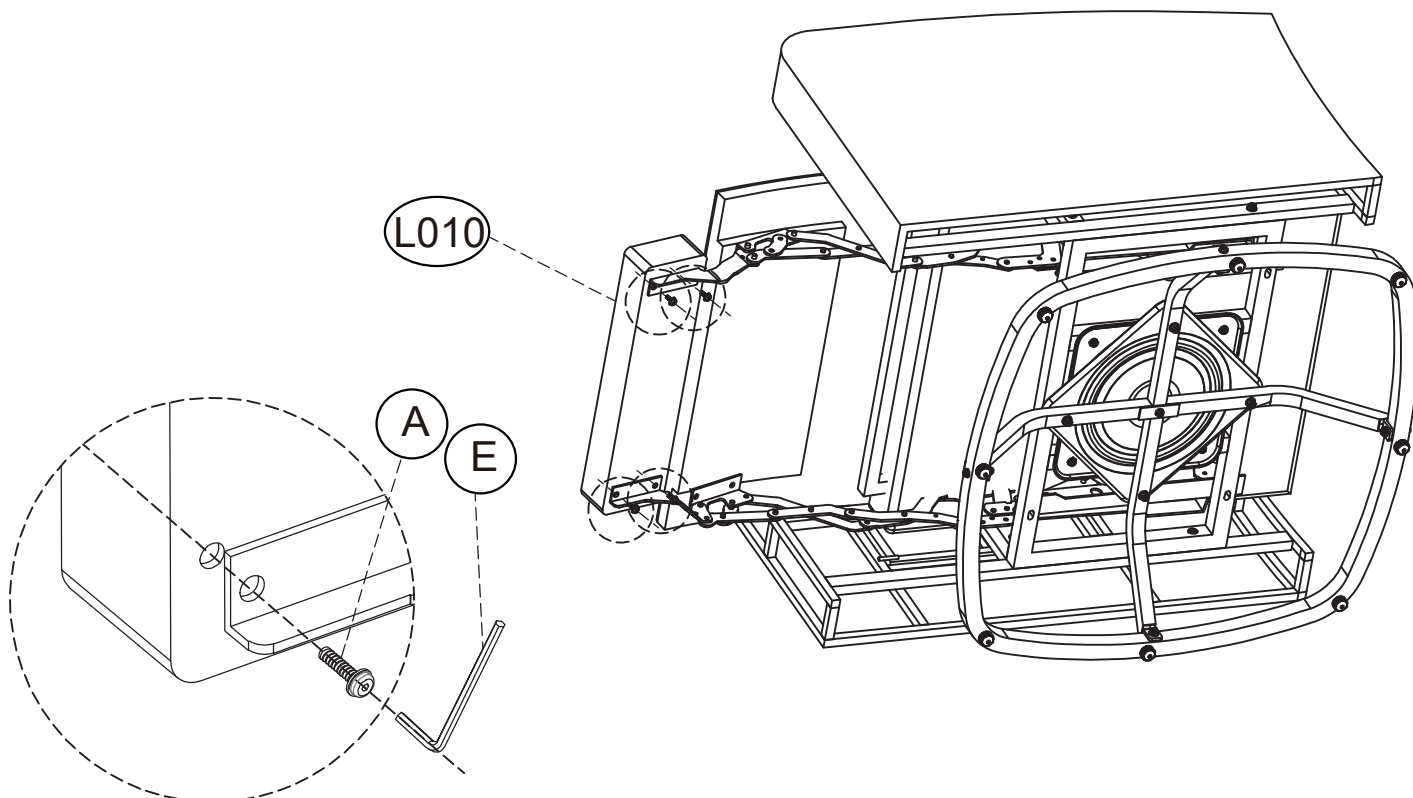

For this installation step, please tighten the screws to 100%

1010

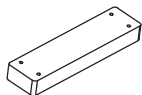

X1

A



M6\*15mm

X4

E



Allen Key(M6mm)

X1

## How to assemble a recline

**Step13** : Fixing the cushion (L007) and the backrest support frame (L006) together.

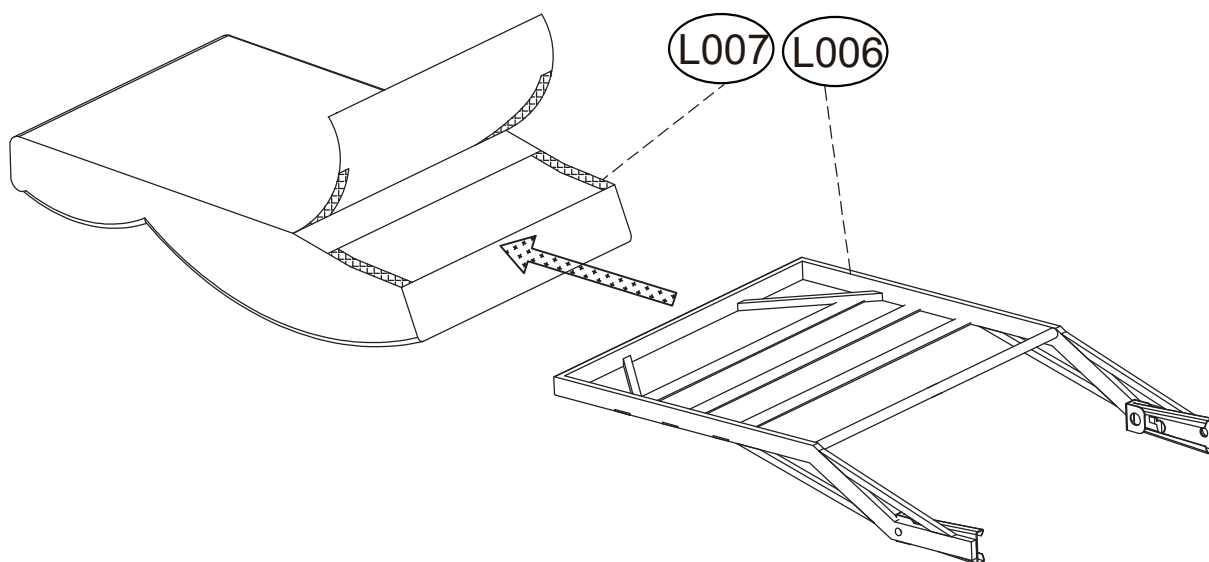

1007

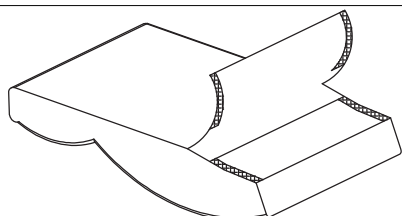

X1

1006

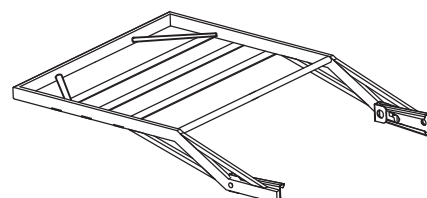

X1

## How to assemble a recline

**Step14 :** Connect and fix the backrest bracket (L006) and telescopic arm (L004,L005), then lower the cushion cover.

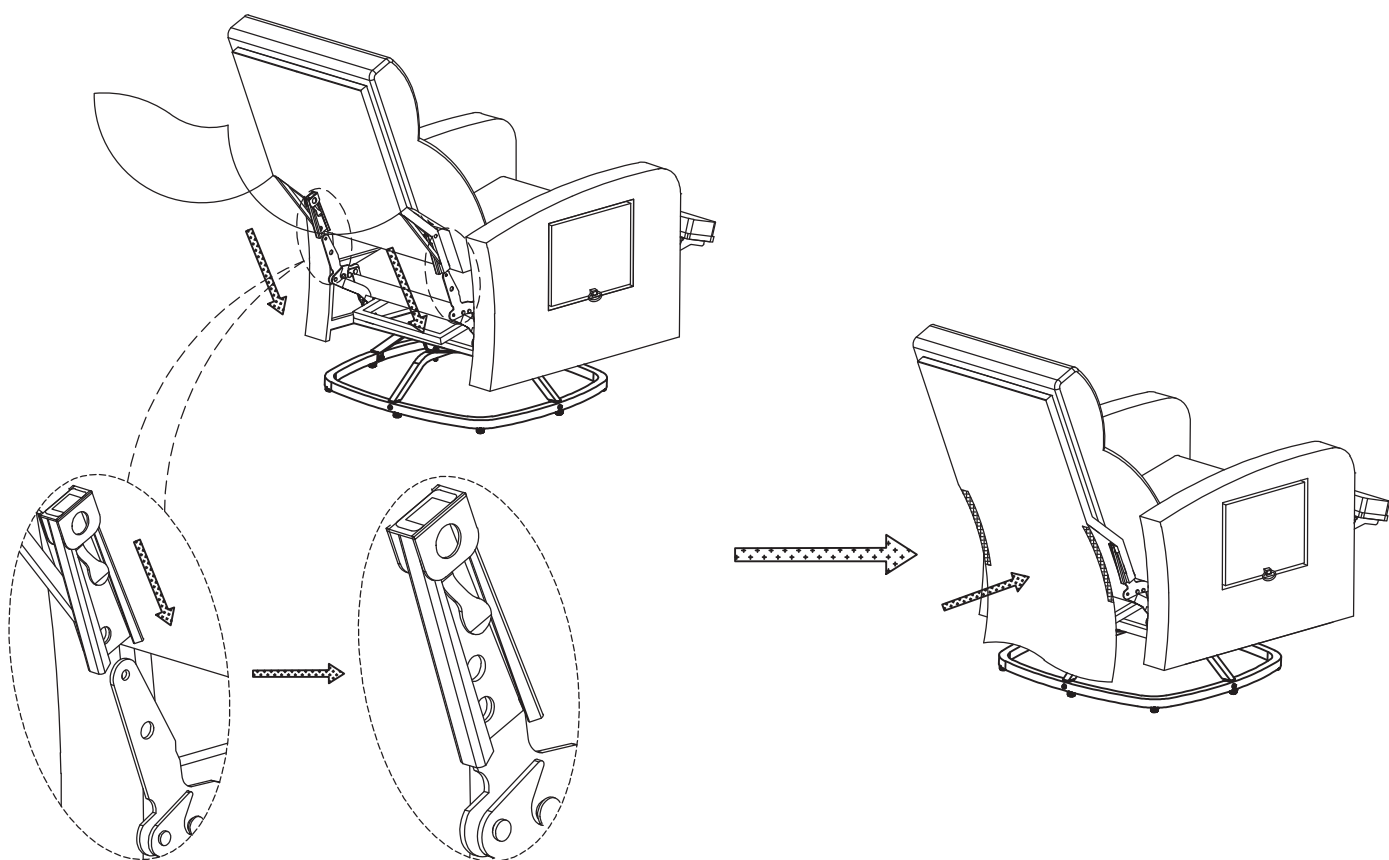

1007

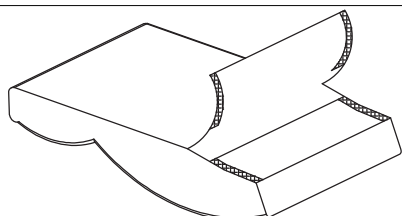

X1

1006

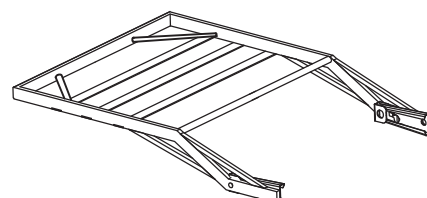

X1

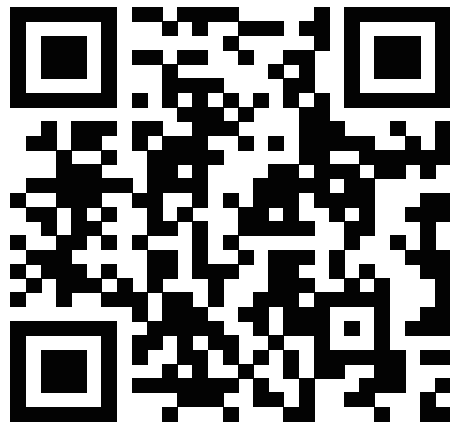

[www.alaulm.com](http://www.alaulm.com)

Make your life much better.

## FAUTEUIL DE JARDIN INCLINABLE

---

Si vous avez des questions sur le kit de relaxation fonctionnelle, n'hésitez pas à nous contacter.

Courriel du service clientèle : [Service@alaulm.com](mailto:Service@alaulm.com)

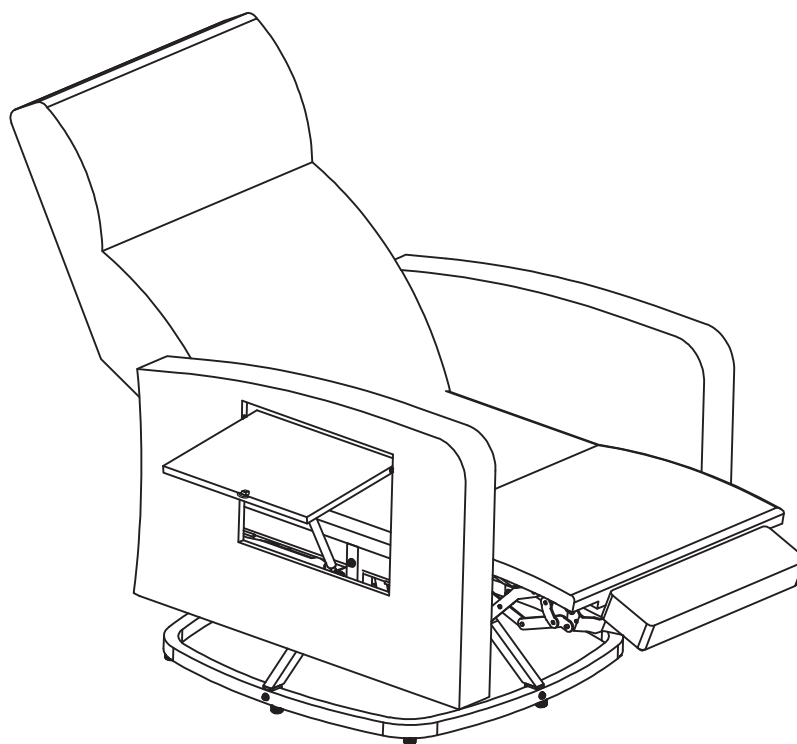

### P25068-D1

**IMPORTANT**

**À LIRE AVANT DE COMMENCER L'ASSEMBLAGE**

Suivez les instructions de ce guide de l'utilisateur pour garantir une utilisation correcte de l'appareil.

assemblage et entretien de ce produit

## catalogue

Specifications.....	01
Catalogue.....	02
Soins et instructions.....	03
Liste des pièces et des jeux de vis.....	04
Extra .....	04
comment faire utiliser le CHAISE LONGUE DE PATIO .....	06



# Avant de commencer

## **Instructions de montage:**

Les instructions sont fournies dans ce manuel et contiennent toutes les informations appropriées pour votre modèle de construction.

Lisez toutes les instructions avant de commencer et pendant l'assemblage suivre l'ordre des étapes soigneusement pour obtenir des résultats corrects.

## **Parts and Parts List:**

Vérifiez que vous disposez de toutes les pièces nécessaires à la construction.

Séparer le contenu du carton en fonction du numéro de pièce lors de l'examen de la liste des pièces.

Familiarisez-vous avec la quincaillerie et les fixations pour faciliter leur utilisation pendant la construction..

Les premières étapes montrent comment assembler des pièces apparentées afin d'obtenir des sous-ensembles plus importants.

être utilisé ultérieurement.

Toutes les pièces sont emballées dans le carton.

Notez que des fixations supplémentaires ont été fournies pour votre commodité.

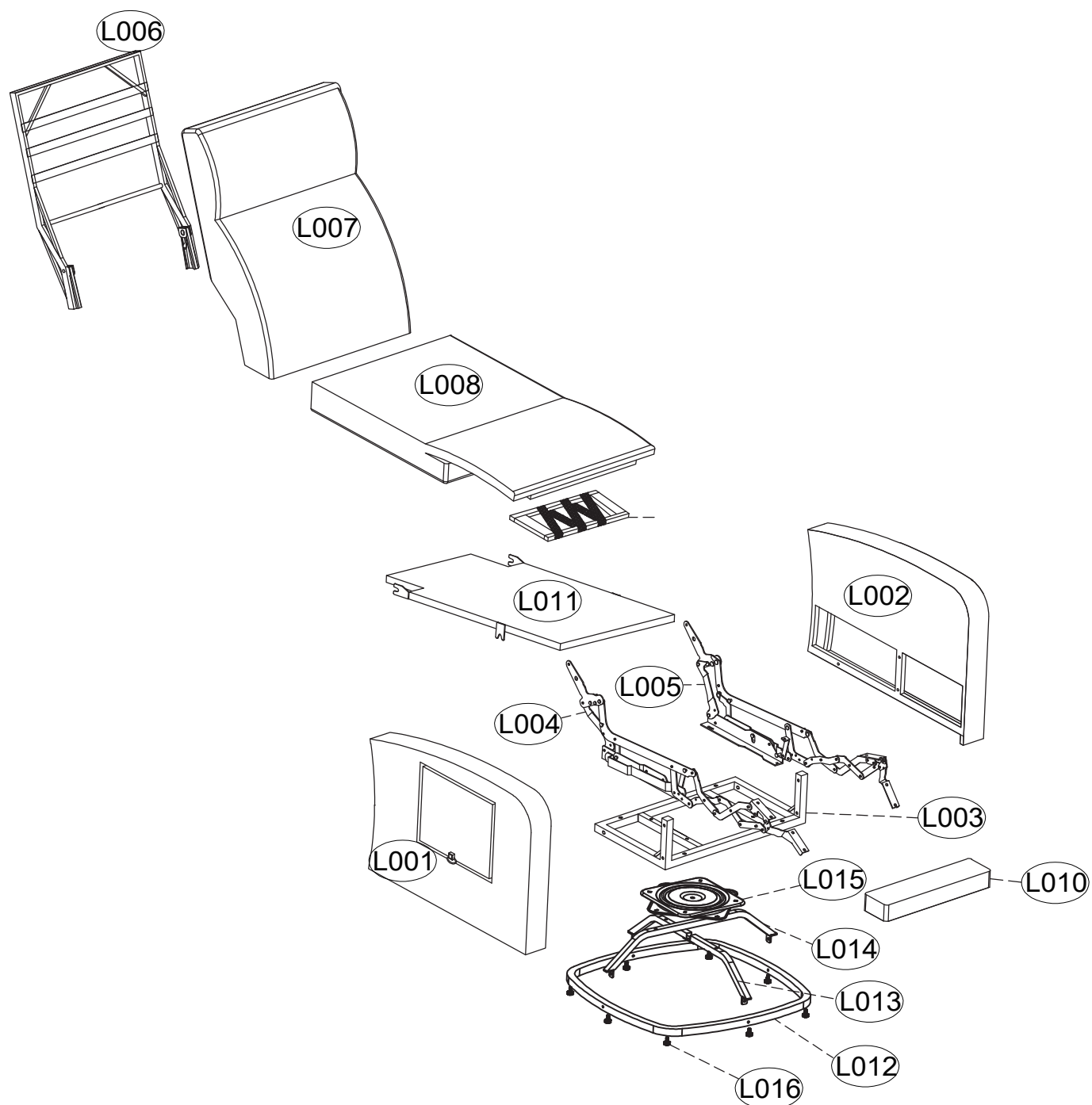

## Comment assembler un fauteuil inclinable

Illustration de la position d'installation de chaque composant





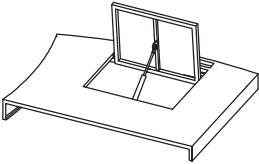
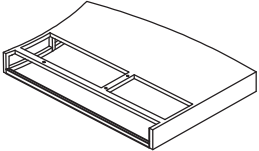
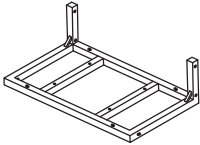
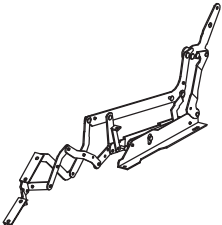
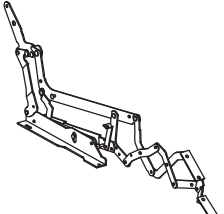
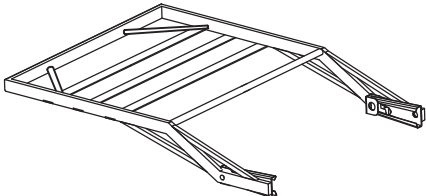
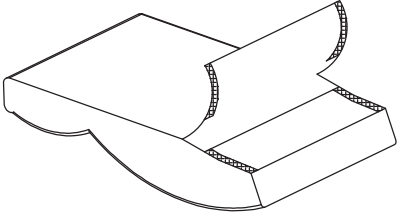
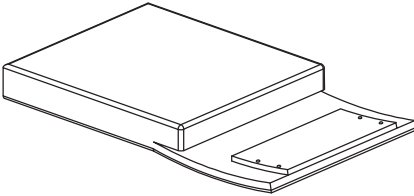

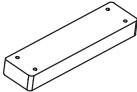
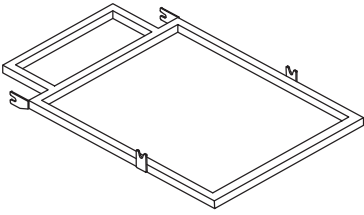
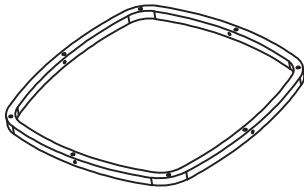
# LISTE DES PARTIES

## Liste des pièces

<p>(L001)</p>  <p>main courante droite</p>	<p>(L002)</p>  <p>main courante gauche</p>	<p>(L003)</p>  <p>montage en rack</p>
<p>1 PC</p>	<p>1 PC</p>	<p>1 PC</p>
<p>(L004)</p>  <p>Bras t é lescopique droit</p>	<p>(L005)</p>  <p>bras t é lescopique gauche</p>	<p>(L006)</p>  <p>Cadre de support du dossier</p>
<p>1 PC</p>	<p>1 PC</p>	<p>1 PC</p>
<p>(L007)</p>  <p>coussins</p>	<p>(L008)</p>  <p>Si è ge (moto)</p>	<p>(L009)</p>  <p>connexion</p>
<p>1 PC</p>	<p>1 PC</p>	<p>1 PC</p>
<p>(L010)</p>  <p>repose-pieds</p>	<p>(L011)</p>  <p>Support de coussin</p>	<p>(L012)</p>  <p>fondation</p>
<p>1 PC</p>	<p>1 PC</p>	<p>1 PC</p>

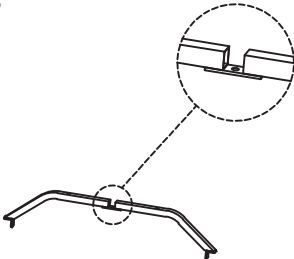



# LISTE DES PARTIES

## Liste des pièces

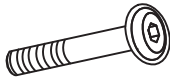
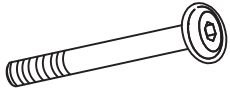

<p>(L013)</p>  <p>ped de chaise</p>	<p>(L014)</p>  <p>ped de chaise</p>	<p>(L015)</p>  <p>arbre à disque</p>
<p>1 PC</p>	<p>1 PC</p>	<p>1 PC</p>
<p>(L016)</p>  <p>pieds r é glables</p>		
<p>8 PCS</p>		

# LISTE DES PARTIES

## Liste des jeux de vis A

<p>(A)</p>  <p>M6*15mm</p>	<p>(B)</p>  <p>M6*35mm</p>	<p>(C)</p>  <p>M6*50mm</p>
<p>9 PCS</p>	<p>16 PC</p>	<p>6 PC</p>
<p>(D)</p>  <p>M6mm</p>	<p>(E)</p>  <p>Clé Allen(M6mm)</p>	<p>(F)</p>  <p>(M6) Clé à molette</p>
<p>22 PC</p>	<p>1 PC</p>	<p>1 PC</p>

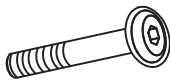
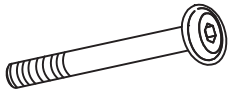
## Extra (Screw Set A)

<p>(A)</p>  <p>M6*15mm</p>	<p>(B)</p>  <p>M6*35mm</p>	<p>(C)</p>  <p>M6*50mm</p>
<p>1 PC</p>	<p>2 PCS</p>	<p>1 PC</p>
<p>(D)</p>  <p>M6mm</p>		
<p>2 PCS</p>		

## SPECIFICATIONS

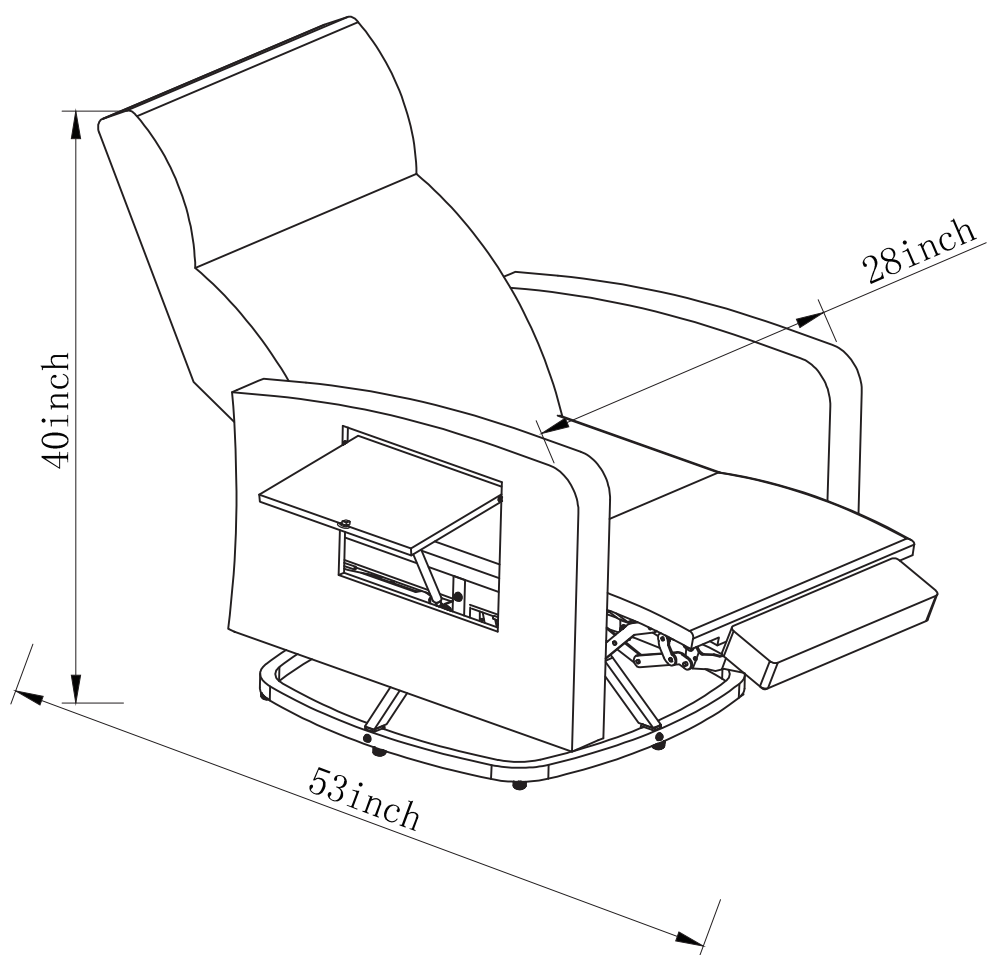

## Comment assembler un fauteuil inclinable

**Étape 1:** Connecter le pied de réglage (L016) à la base (L012).

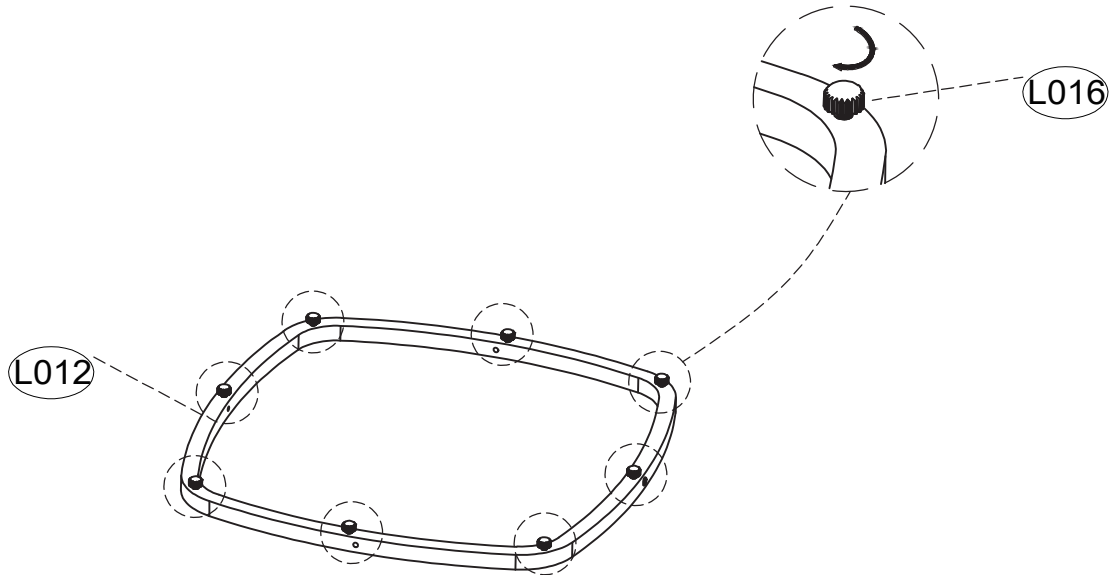

L012

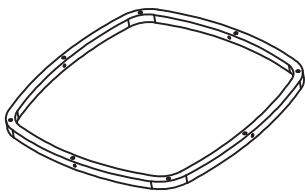

x1

L016



x8

**Étape 2:** Fixer les pieds de la chaise (L013) et les pieds de la chaise (L014) à l'aide des vis (A).

**NOTE:** Ne pas serrer les vis à fond.

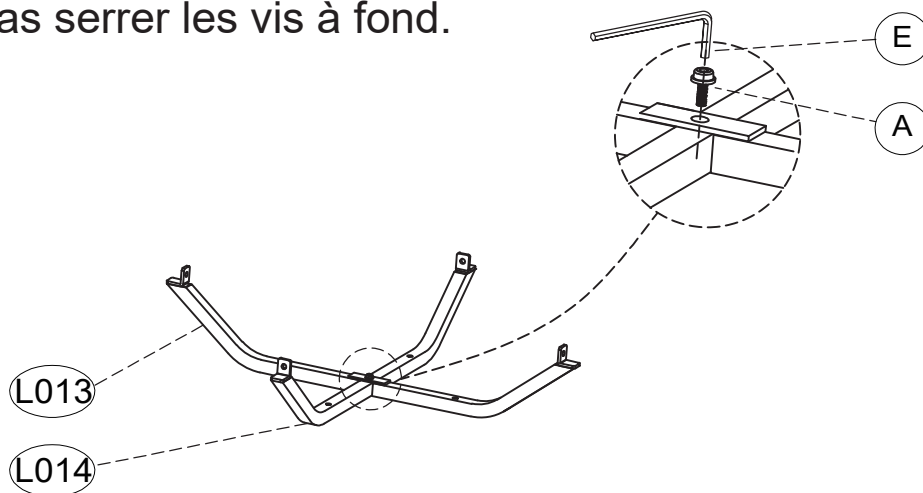

L013

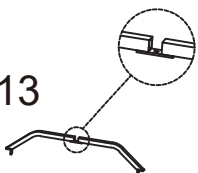

x1

L014



x1

E



x1

A



x1

Clé Allen (M6mm)

M6\*15mm

## Comment assembler un fauteuil inclinable

**Étape 3:** Fixez la base (L012) et les pieds de la chaise (L013, L014) à l'aide des vis (B) et des écrous (D) de

**NOTE:** Ne pas serrer les vis à fond.

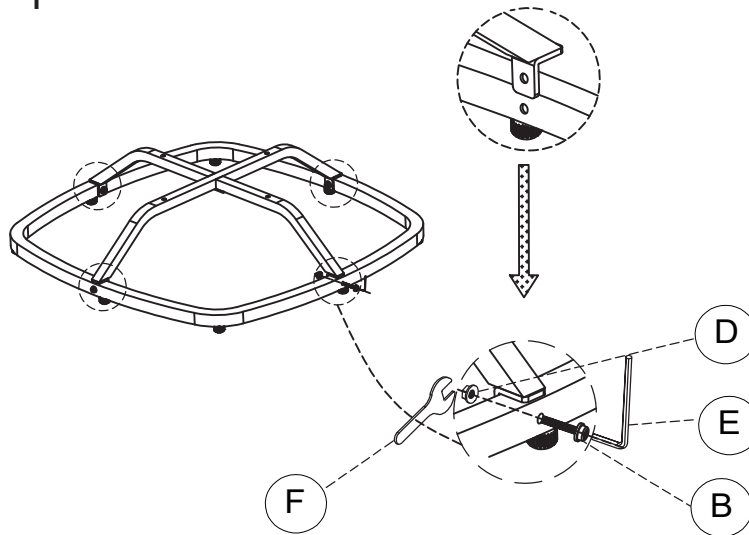

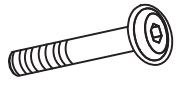
B  x4  
M6\*35mm

D  x4  
M6mm

E  x1  
Clé Allen(M6mm)

F  x1  
Clé à molette

**Étape 4:** Fixer les pieds de la chaise (L013, L014) et l'arbre du disque (L015) avec les vis (B) et les écrous (D) de

**NOTE:** Ne pas serrer les vis à fond.

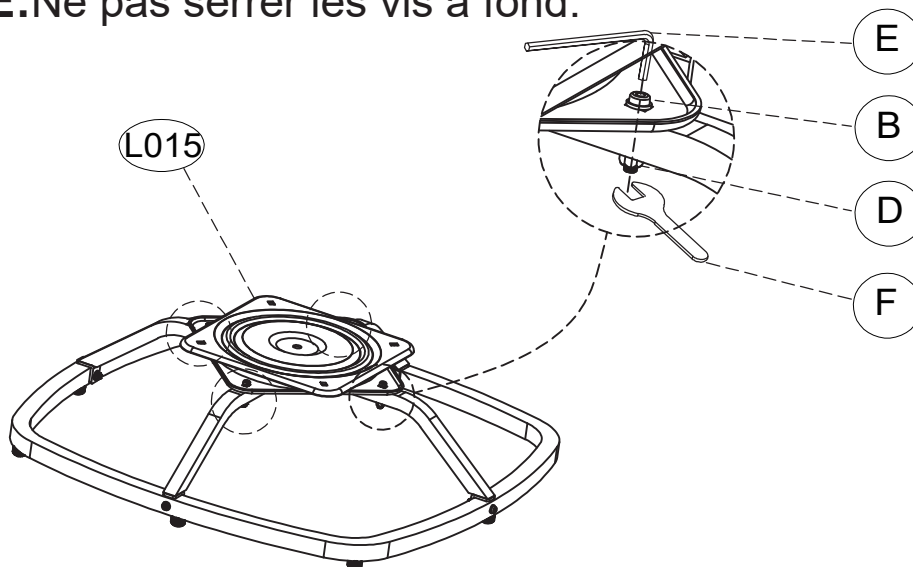

L015  x1

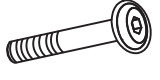
B  x4  
M6\*35mm

E  x1  
Clé Allen(M6mm)

D  x4  
M6mm





F  x1  
Clé à molette(M6)

## Comment assembler un fauteuil inclinable

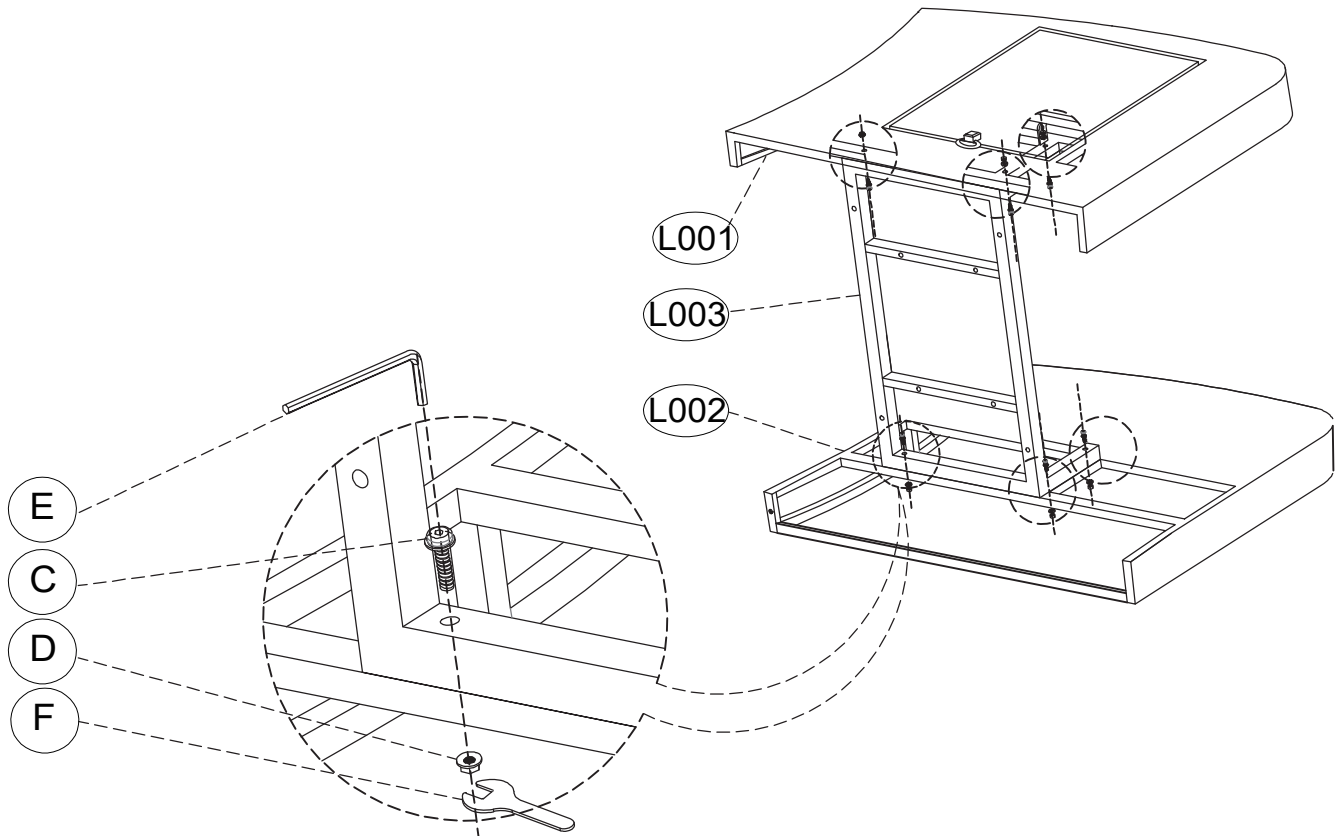
**Étape 5:** Relier l'accoudoir gauche (L002) et l'accoudoir droit (L001) au cadre (L003) à l'aide de vis (C) et d'écrous (D).

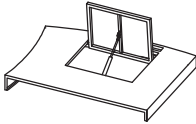
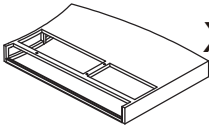
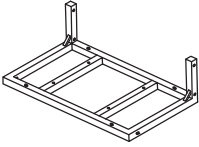
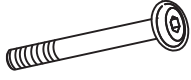
**NOTE:** Ne pas serrer les vis à fond.



<p>L001 X1</p> 	<p>L002 X1</p> 	<p>L003 X1</p> 	<p>C X6</p>  <p>M6*50mm</p>
<p>D X6</p>  <p>M6mm</p>	<p>E X1</p>  <p>Clé Allen(M6mm)</p>	<p>F X1</p>  <p>Clé à molette(M6)</p>	

## Comment assembler un fauteuil inclinable

Étape 6 :

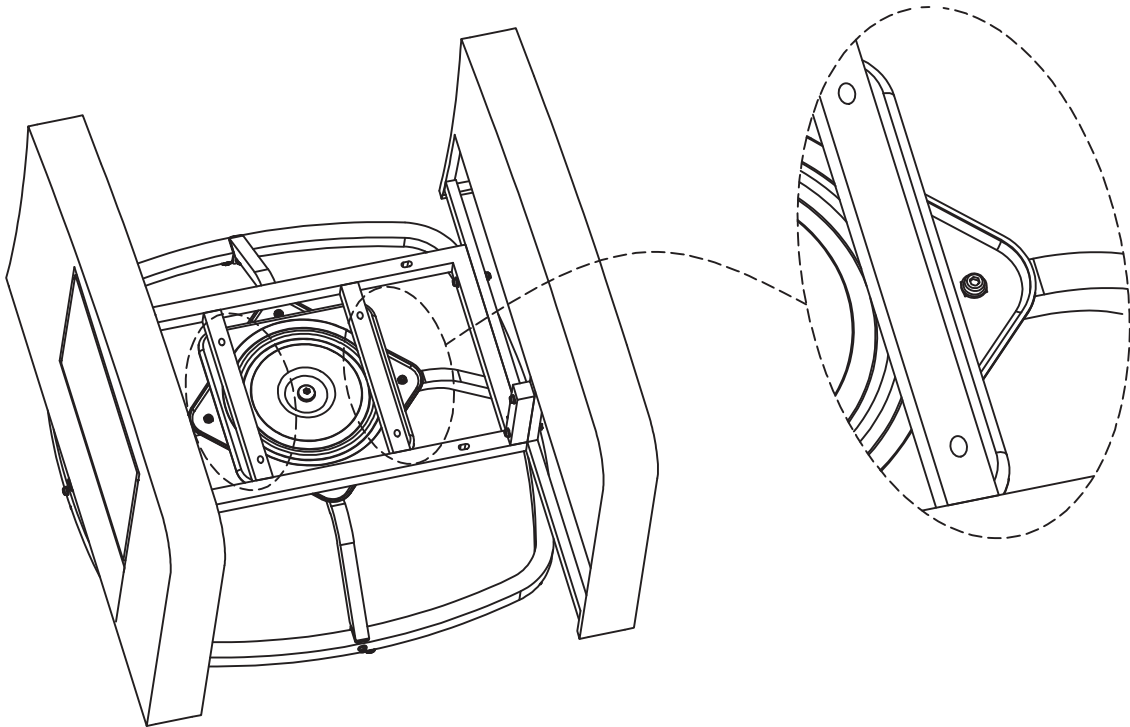

**1:Placez le rack sur le châssis**

**2:Faites-le pivoter dans la position appropriée avant de passer à l'étape d'installation suivante.**

## Comment assembler un fauteuil inclinable

**Étape 7 :** Relier la base (L012) au cadre (L003) via l'arbre du disque (L015) à l'aide des vis (B) et des écrous (D).

**NOTE:** Ne pas serrer les vis à fond.

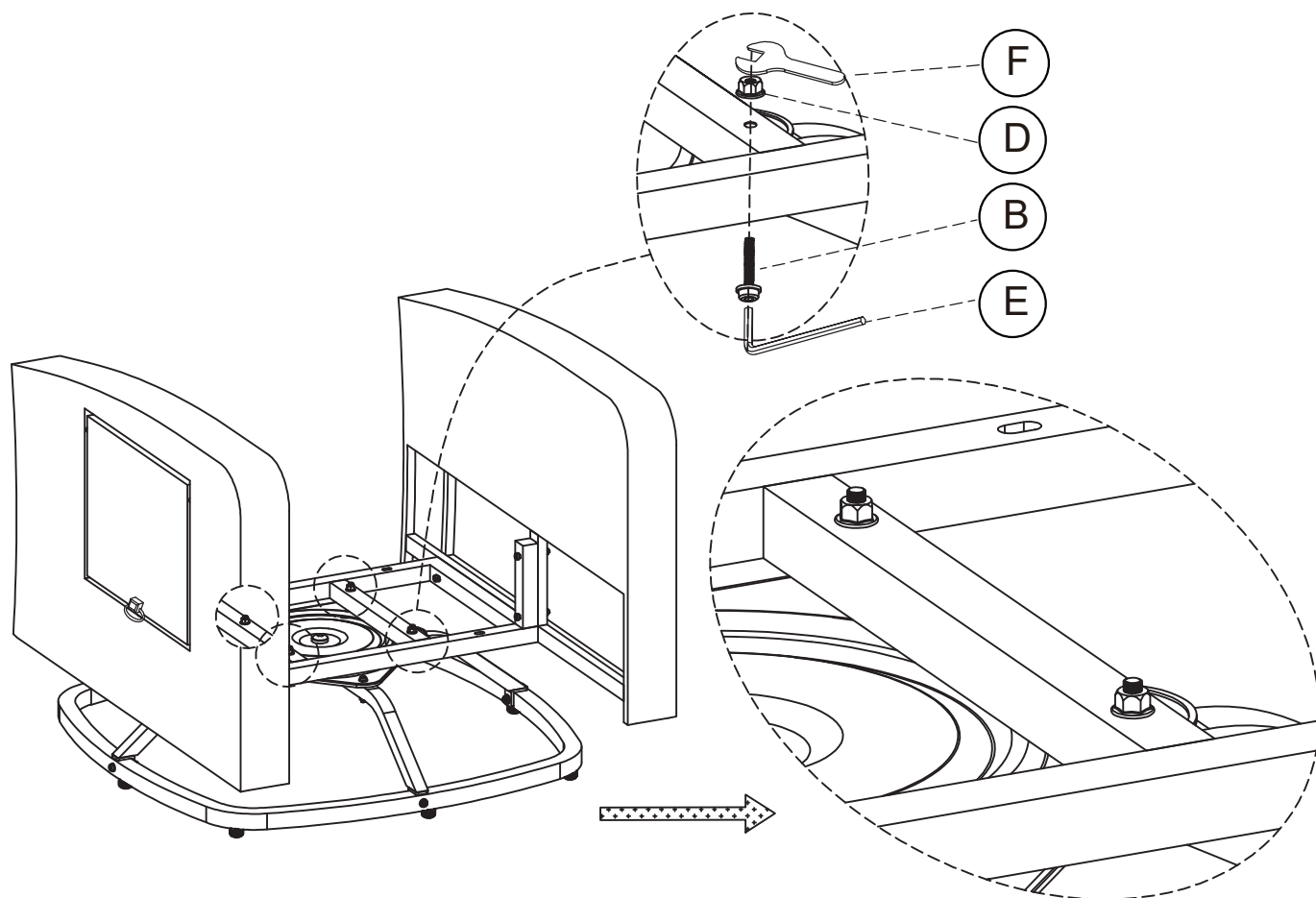

F  X1  
Clé à molette(M6)

D  X4  
M6mm

B  X4  
M6\*35mm

E  X1  
Clé Allen(M6mm)

## Comment assembler un fauteuil inclinable

**Étape 8 :** Relier les bras télescopiques (L004, L05) et le cadre (L003) à l'aide de vis (B) et d'écrous (D).

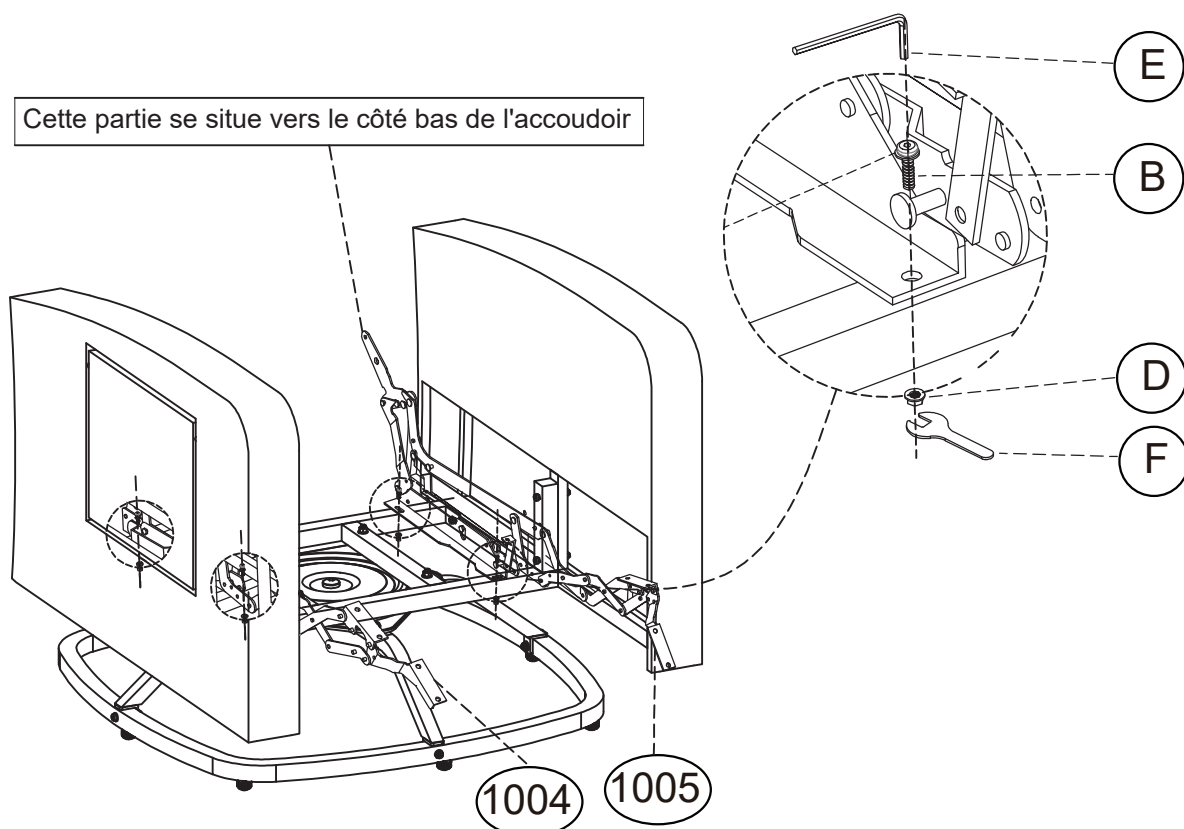

<p>1004 X1</p>	<p>1005 X1</p>	<p>E X1</p> <p>Clé Allen(M6mm)</p>	<p>B X4</p> <p>M6*35mm</p>
<p>D X4</p> <p>M6mm</p>	<p>F X1</p> <p>Clé à molette(M6)</p>		

## Comment assembler un fauteuil inclinable

**Étape 9** : Installez les supports de coussin (L011) sur les bras télescopiques avant et arrière de (L004, L05).

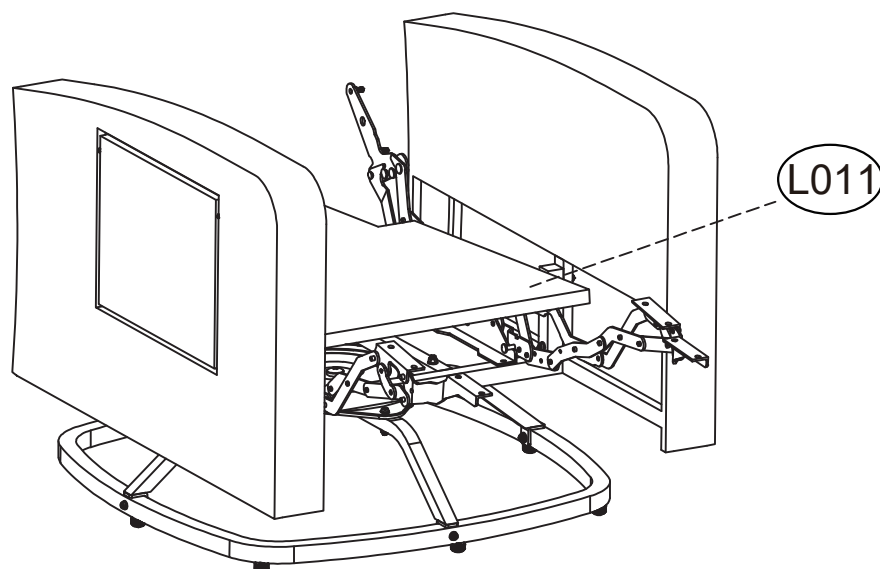

### Décomposition du schéma d'assemblage

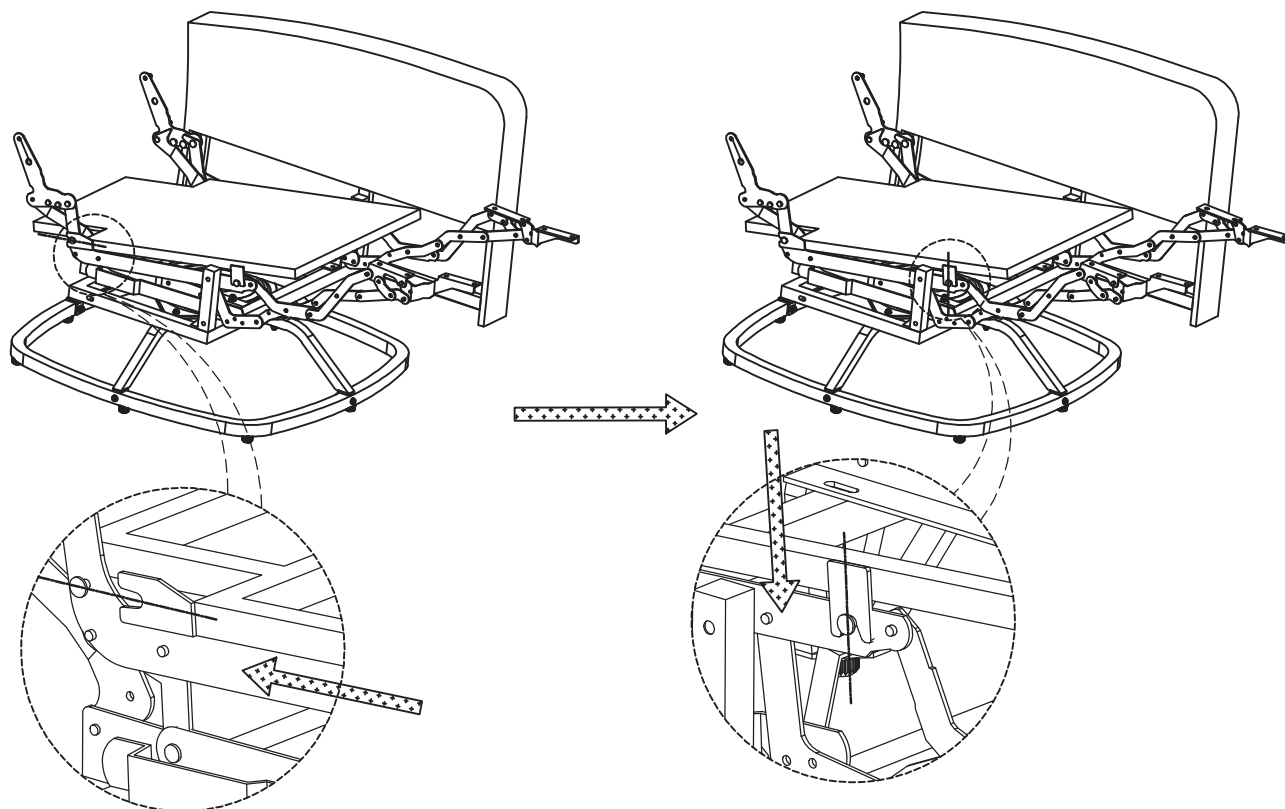

1011

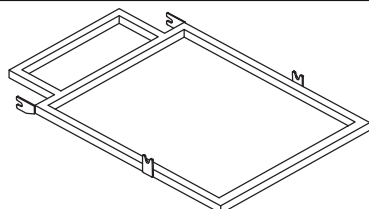

X1

## Comment assembler un fauteuil inclinable

**Étape 10** : Placer le connecteur (L009) à l'intérieur du coussin (L008) et le fixer.

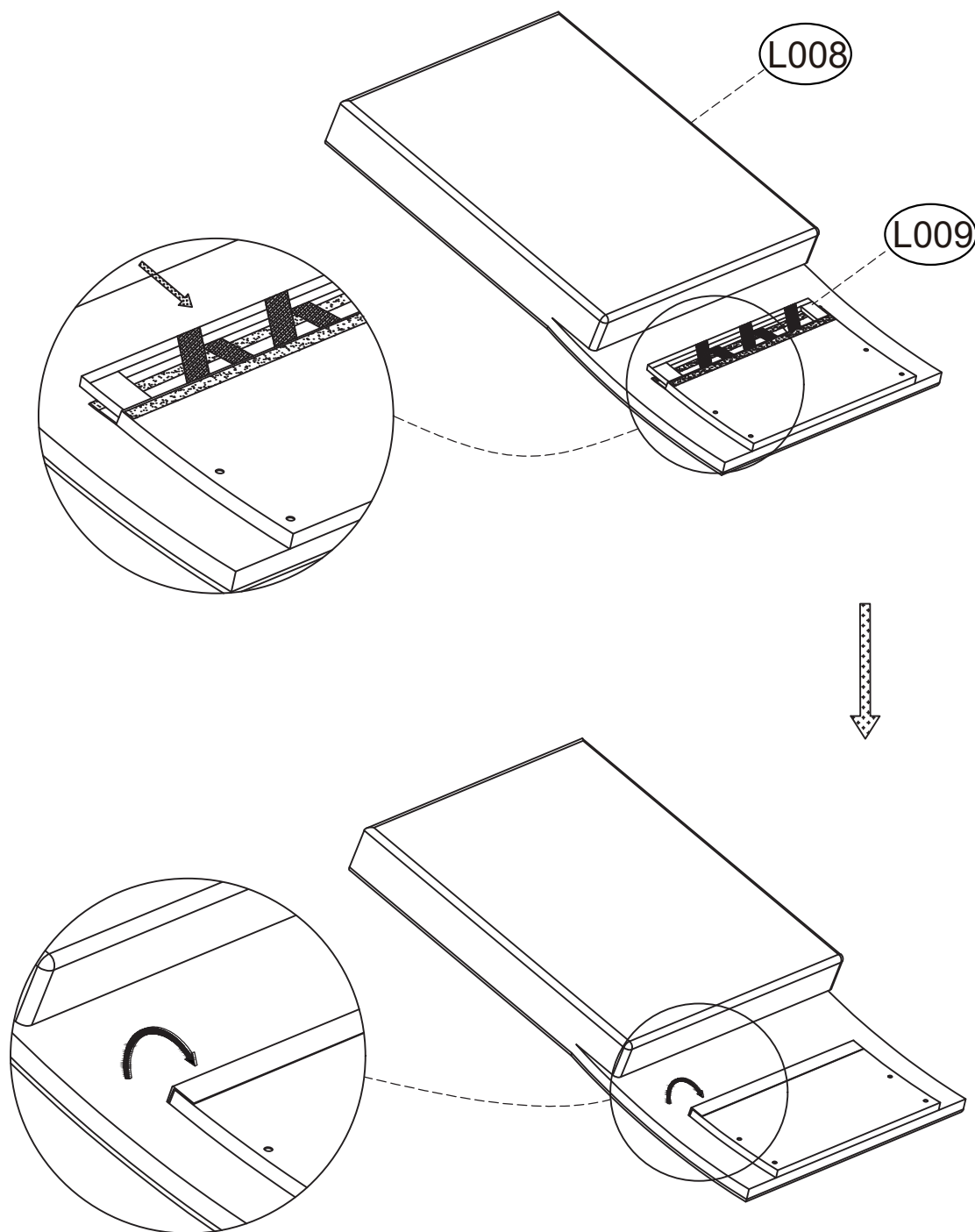

1008

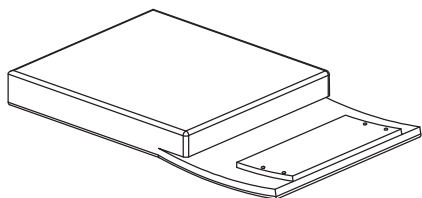

X1

1009



X1

## Comment assembler un fauteuil inclinable

**Étape 11** : Fixez le coussin (L008) et le bras télescopique (L004, L005) à l'aide des vis (A).

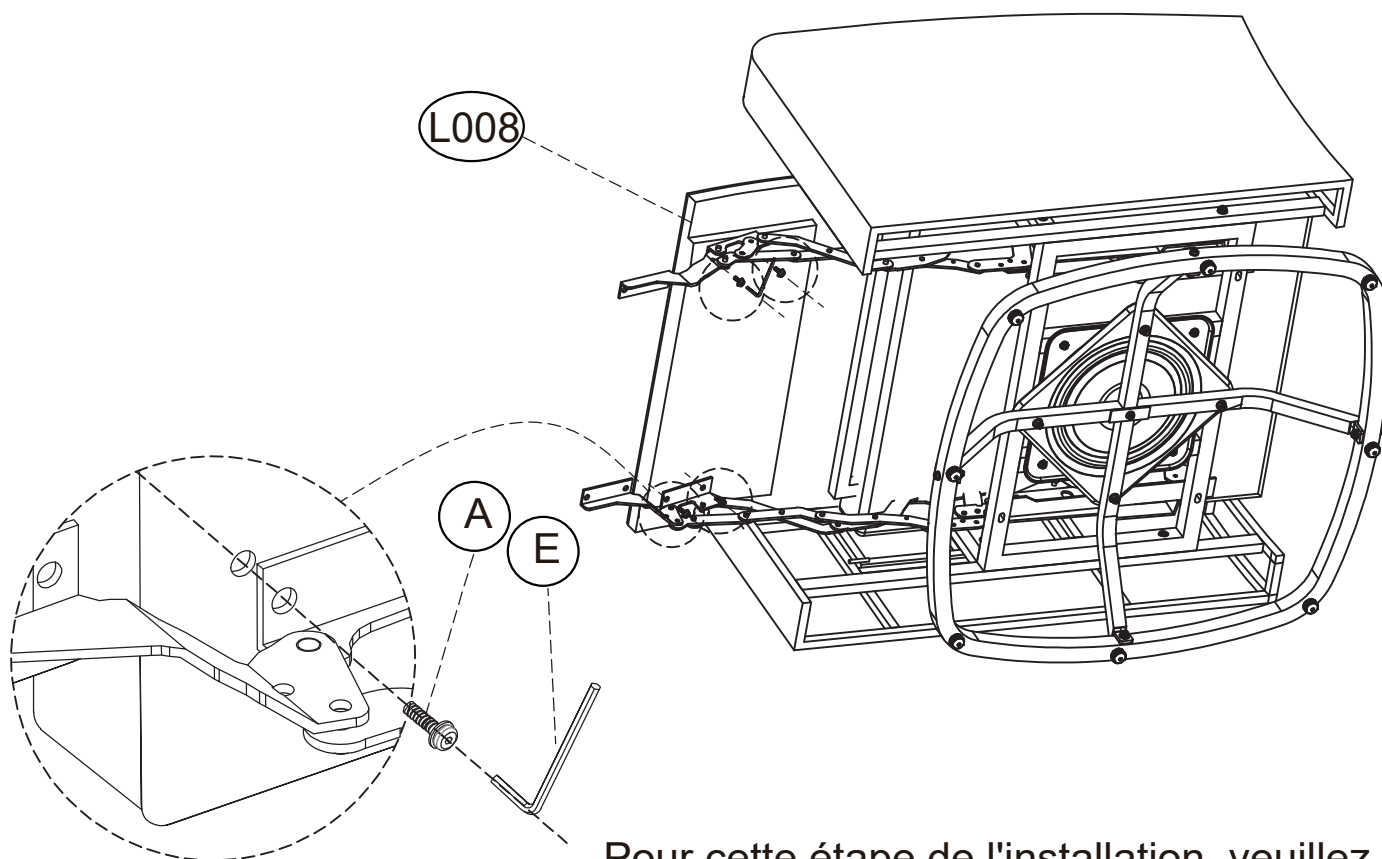

Pour cette étape de l'installation, veuillez serrer les vis à 100%

1008

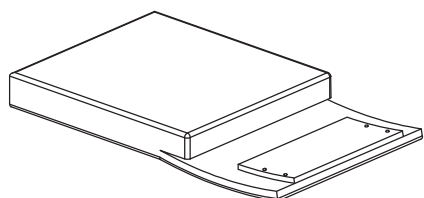

X1

A



M6\*15mm

X4

E



Clé Allen(M6mm)

X1

## Comment assembler un fauteuil inclinable

**Étape 12** : Fixer le repose-pieds (L010) et le bras télescopique (L004, L005) à l'aide des vis (A).

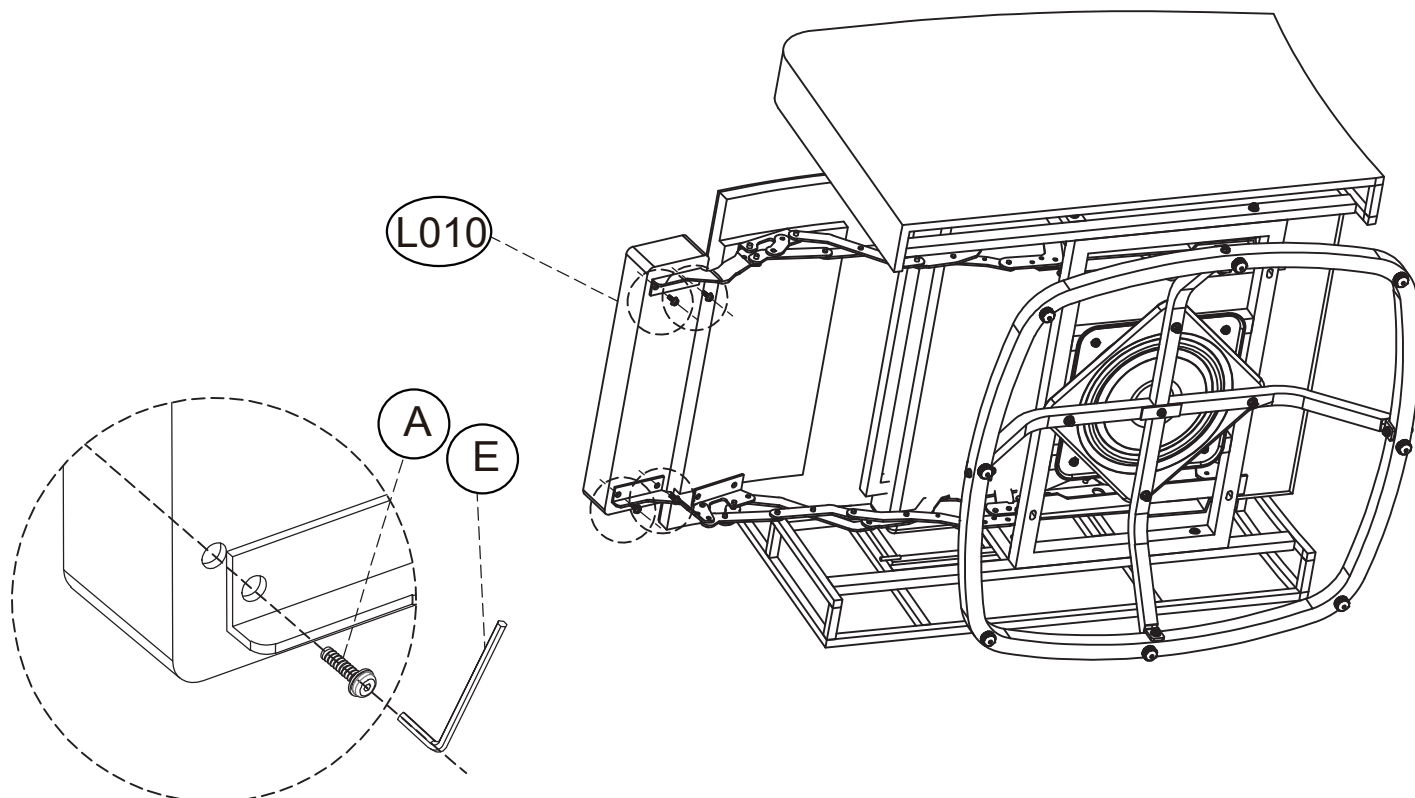

Pour cette étape de l'installation, veuillez serrer les vis à 100%

1010

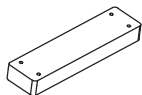

X1

A



M6\*15mm

X4

E



Clé Allen(M6mm)

X1

## Comment assembler un fauteuil inclinable

**Étape 13** : Fixer le coussin (L007) et le cadre de support du dossier (L006) ensemble.

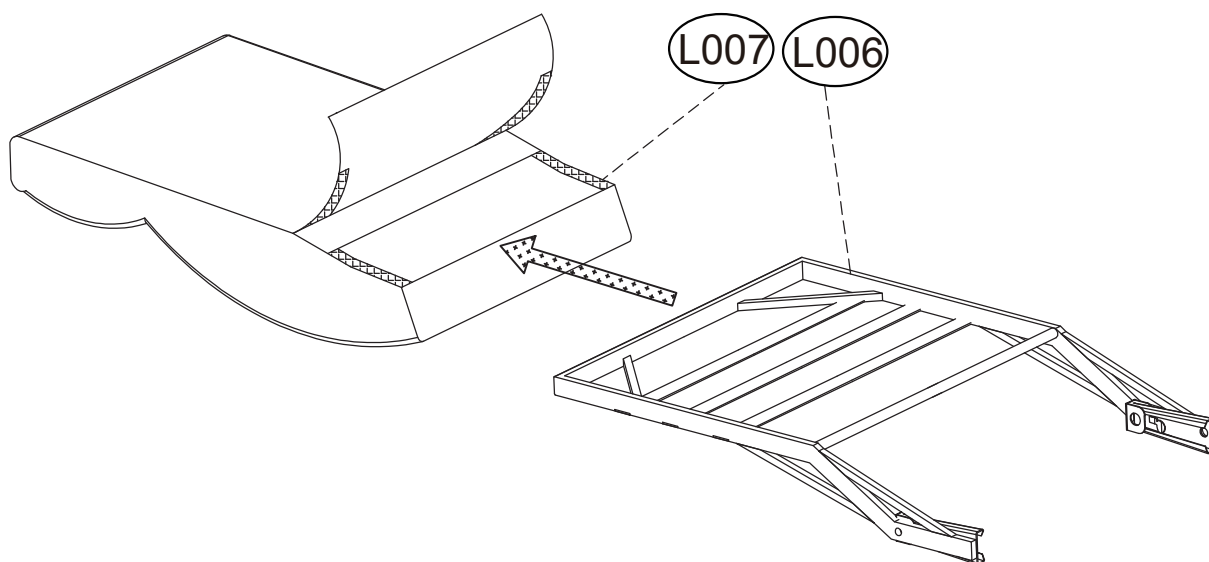

1007

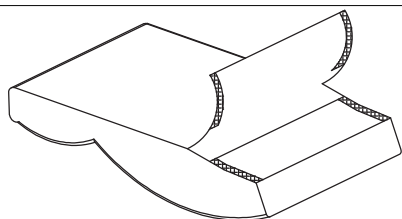

X1

1006

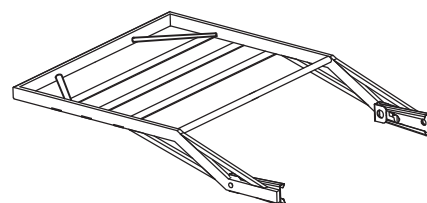

X1

## Comment assembler un fauteuil inclinable

**Étape 14 :** Connectez et fixez le support de dossier (L006) et le bras télescopique (L004,L005), puis abaissez la housse de coussin.

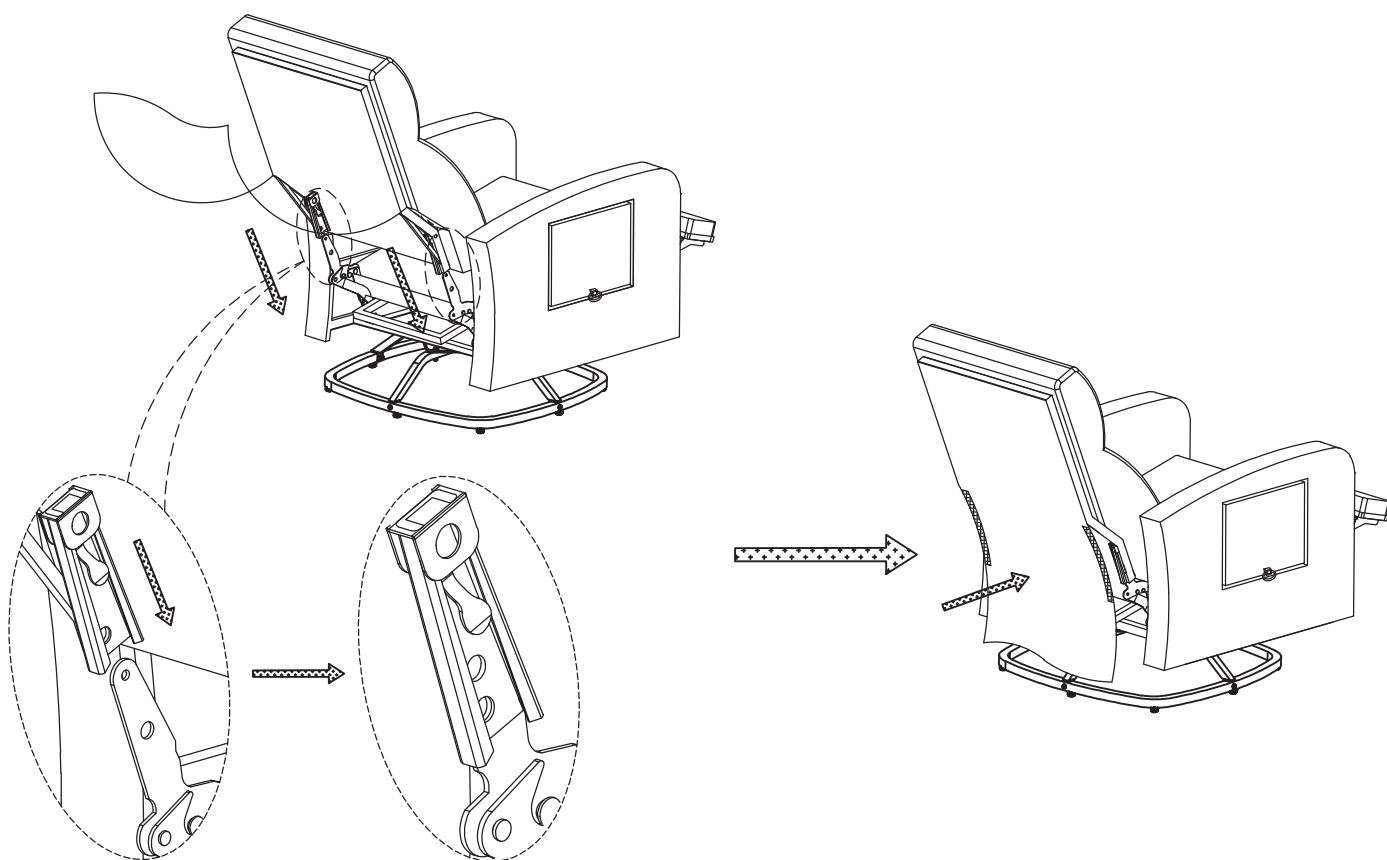

1007

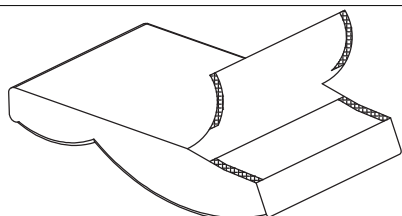

X1

1006

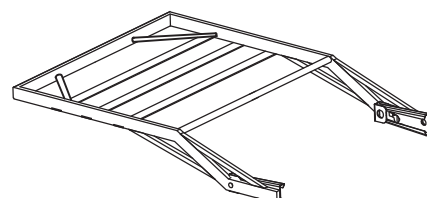

X1

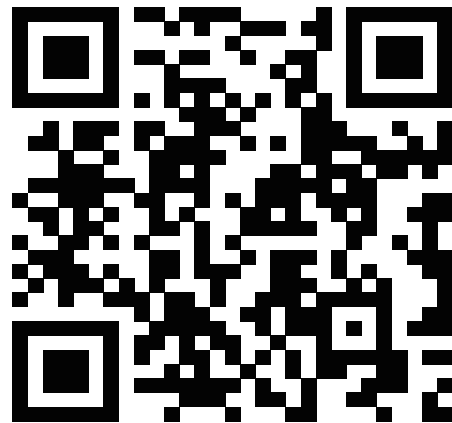

[www.alaulm.com](http://www.alaulm.com)

Améliorez votre vie