



ASSEMBLY INSTRUCTION



Read the instructions book carefully before you set up the product to avoid damaging the parts.

Spare Parts

 A Table x1	 B Screw x2	 C Wrench x1
---	---	--

Warning

1. Please do not exceed the maximum load capacity of the product. The maximum loading capacity of the table is 80kg.
2. Please tighten all bolts, screws, and knobs firmly before use.
3. Please do not tighten the screws until the item is fully assembled.
4. Please lock the parts after adjustment. The unsecured table may affect your child's safety.
5. Please recheck all bolts, screws and knobs are secure every 90 days.
6. Please do not use or store the product near open flame or flammable/combustible chemicals.
7. Please use the product in strict accordance with the instructions; otherwise, the service life of the product may be reduced or the product may be damaged.
8. The desktop is made of environmentally friendly MDF material. If you need to place high-temperature objects, such as a hot pot or hot plate, it is recommended to place a heat insulation pad. Daily cleaning can be wiped with a soft cotton cloth.
9. The lifting device can be replaced after many years of use. Generally, the service life of the lifting device is at least 5 years.
10. Please pay attention to avoid collision with hard objects in daily use. In this case, the table paint may fall off.
11. Please do not use power tools to assemble the product, otherwise, it will invalidate any claim and may damage the product and make it unsafe.
12. Please complete the installation in a flat and clean place to avoid scratching the desktop.
13. The new airlift device is powerful, and the initial height adjustment requires more pressure on the table.

1 Assemble the frame

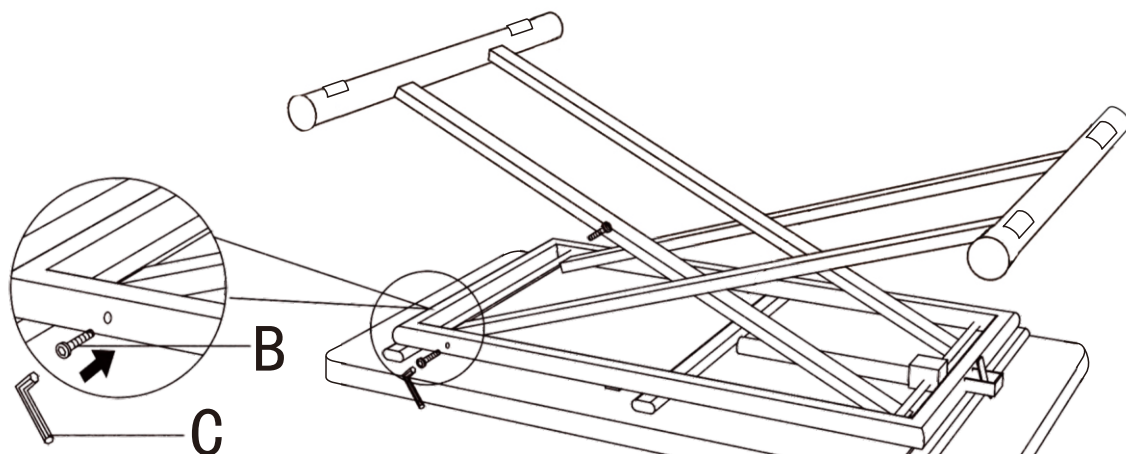

Lift the shelf to align the holes here and tighten the screws

2 Remove the location restriction screw

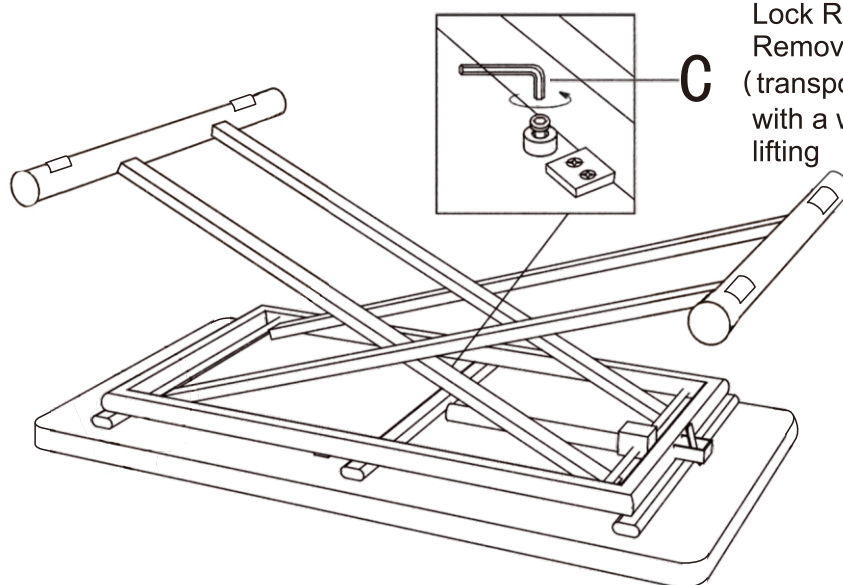

Lock Removing:
Remove the screw
(transport safety lock)
with a wrench before
lifting

3

Turn the table over as a whole
and complete the installation

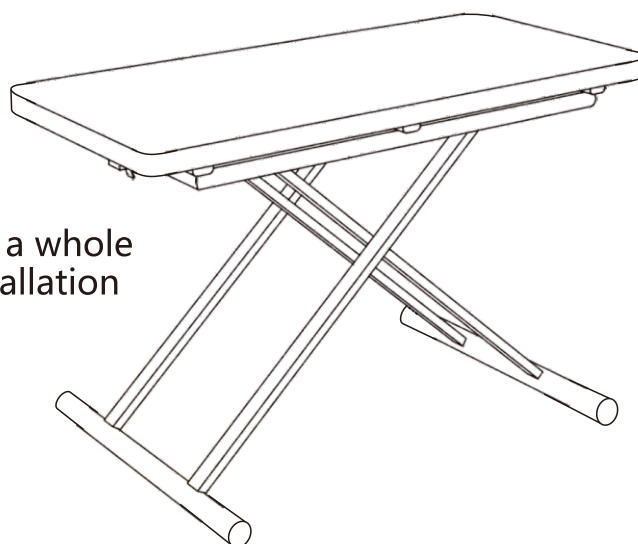

4

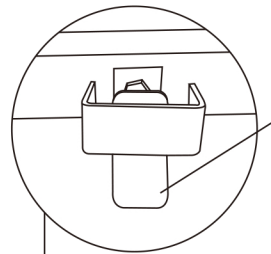

Pull up the lifting adjusting wrench and hold can adjust the height of table.

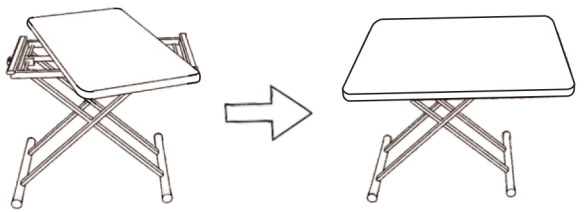

Pull the wrench to fix and loosen the caster

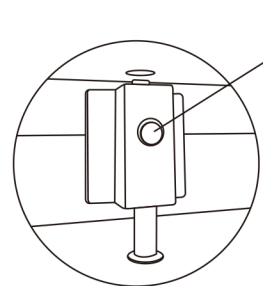

Press the desktop fixed button, and the desktop can rotate

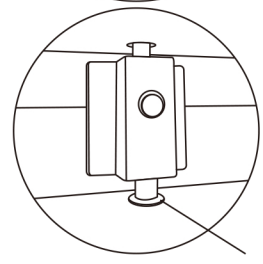

Press the desktop fixed button, and the desktop cannot be rotated

5

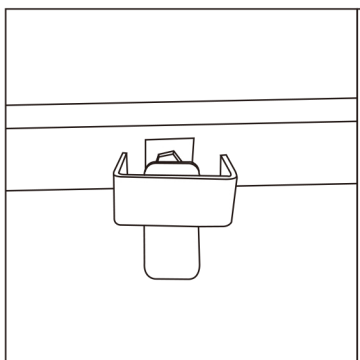

STEP1: Pull up the lifting adjusting wrench

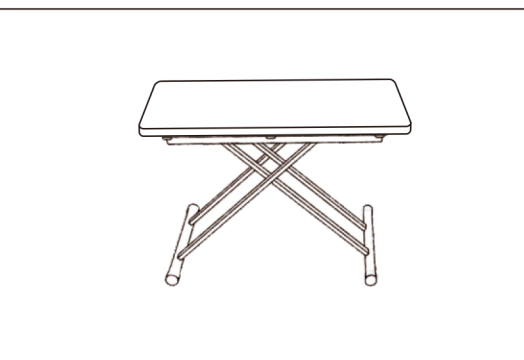

STEP2: Press the table to reduce the height of the table.



STEP3: Pull up the lifting adjusting wrench and lift the table top upward to improve the height of the table.

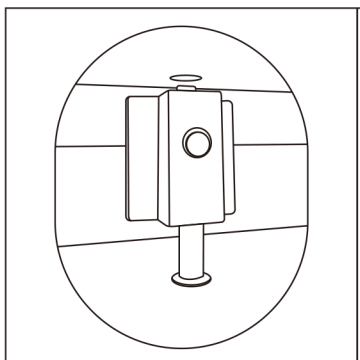

STEP1: Press the desktop fixed button to rotate the desktop, as shown in Figure 4

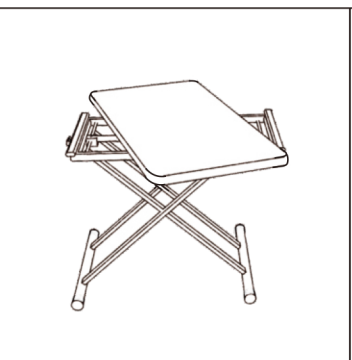

STEP2: Press the fixed button on the desktop after rotation to make the desktop non-rotatable, as shown in Figure 4

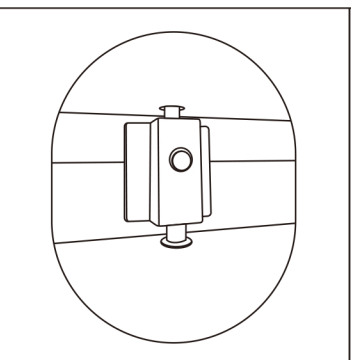

STEP3: Press the desktop fixed button, and the desktop cannot be rotated



STEP4: Rotate and open the table top to increase the size of the table top 100X110cm