

WOOD BED

ASSEMBLY INSTRUCTION

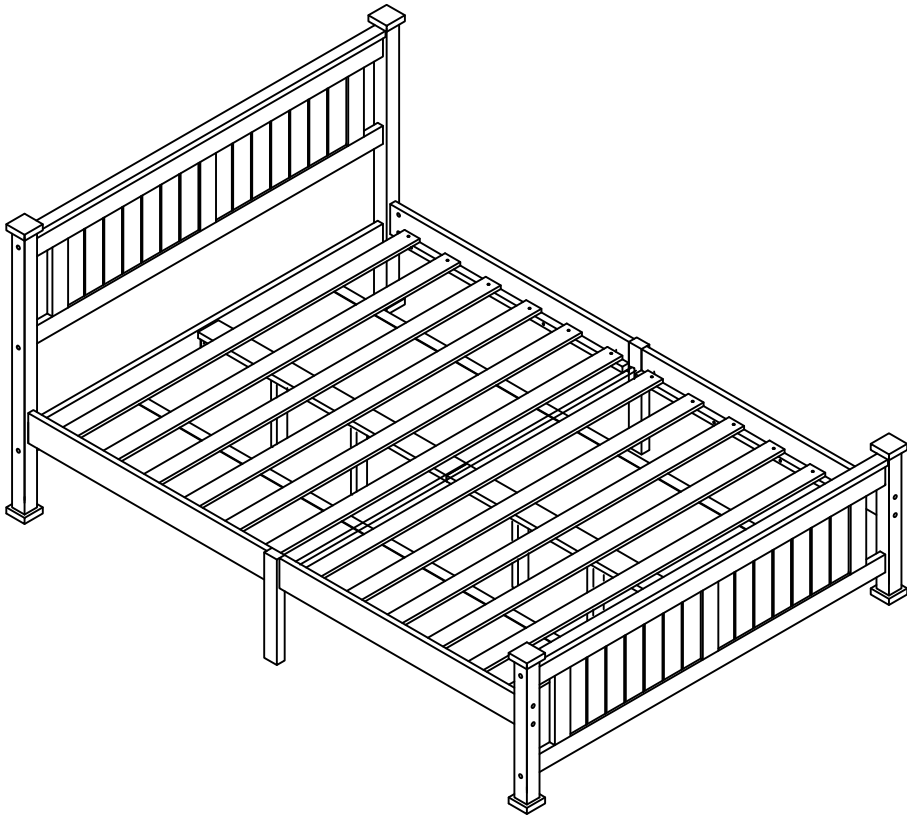

RETURN & WARRANTY

Thank you for choosing our product!

We would like to take this opportunity to thank you for choosing product.

We hope that you are completely satisfied with your purchase, and enjoy it for years to come.

Your satisfaction is our highest pursuit.

Return Policy

Production believes you will absolutely love your wood bed, but if for some reason you want to return the product, please contact us directly before you decide to return your product to the retailer. Our Customer Service organization can answer most concerns and can assist you with any questions you may have about your new product.

The item must be returned in good condition, in original box, with all original proof of purchase, parts and accessories, within the time frame specified by the retailer it was purchased from.

Warranty

Warrants this product to be free from defects in material and workmanship agrees to remedy any such defect. This warranty covers one year from the date of original purchase. This is solely limited to be repair or replacement of defective parts and no assembly labor is included.

This warranty does not apply to any product which has been improperly assembled, subjected to misuse or abuse or which has been altered or repaired in anyway.

Components repaired or replaced warranted through the remainder of the original warranty period only. The defective components will be repaired or replaced without charge, subject to the terms and conditions described above.

BEFORE STARTING

Before Using Product



- Read each step carefully before starting. It is very important that each step is performed in the correct order. If these steps are not followed in sequence, assembly difficulties will occur.



- Make sure all parts are included. Most board parts are labeled or stamped on the raw edge.

- Have the following tools.



- Recommended # of people needed for assembly: 2 (however it is always better to have an extra hand). Estimated assembly time is 2.5hours.



- Work in a spacious area and near where the unit will be used, preferably on a carpet, or use a piece of the cardboard packaging to protect your floor and product.



- For a smooth assembly process, we suggest you keep a lite tightness for all the screws during assembly. After the whole product is assembled, firmly tighten all the screws.

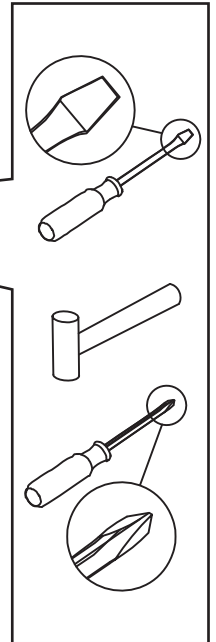

WARNING:

- Do not allow children to climb on unit
- Serious or fatal crushing injuries can occur from furniture tip-over. To prevent this furniture from tipping over, it must be permanently fixed to the wall. Fixing devices for the wall are not included since different wall materials require different types of fixing devices. Use fixing devices suitable for the walls in your home. For advice on suitable fixing systems, contact your local specialized dealer.
- Avoid sharp objects or corrosive chemicals to prevent damage to the product
- During assembly, keep parts and packaging materials away from children and pets as there could be potential injury and choking hazards.

ASSEMBLY TIPS

Applicable Model

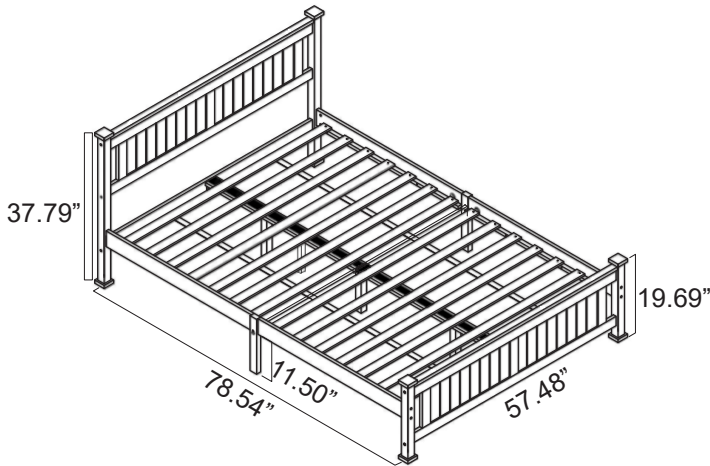

MODEL: PBOPFW

DIMENSION Outside Dimensions:
78.54"L x 57.48"W x 37.79"H
(Headboard)x 19.69"H(Footboard)
Inner Frame Size: 53.94"Wx73.94"L

FEATURES 100% Solid Pine Wood with White Paint
Load-Capacity: 286LB

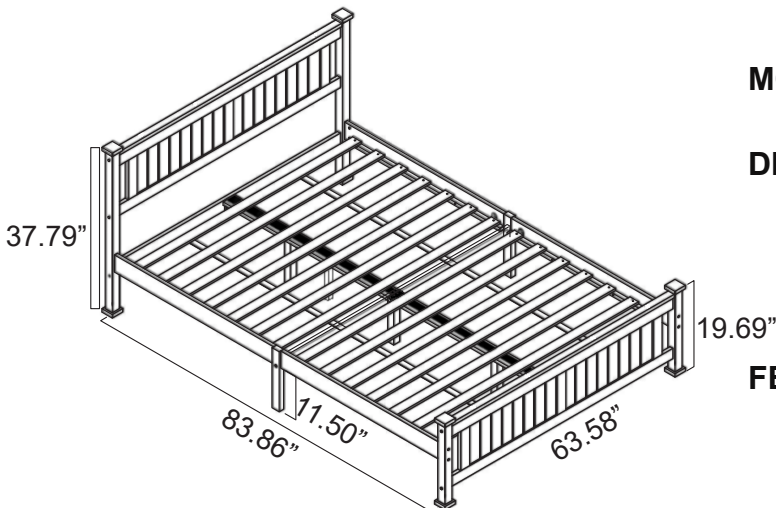

MODEL: PBOPWQW

DIMENSION Outside Dimensions:
83.86"L x 63.58"W x 37.79"H
(Headboard)x 19.69"H(Footboard)
Inner Frame Size: 60.24"Wx79.06"L

FEATURES 100% Solid Pine Wood with White Paint
Load-Capacity: 308LB



Estimated Time for Assembly

70 mins

Caution:







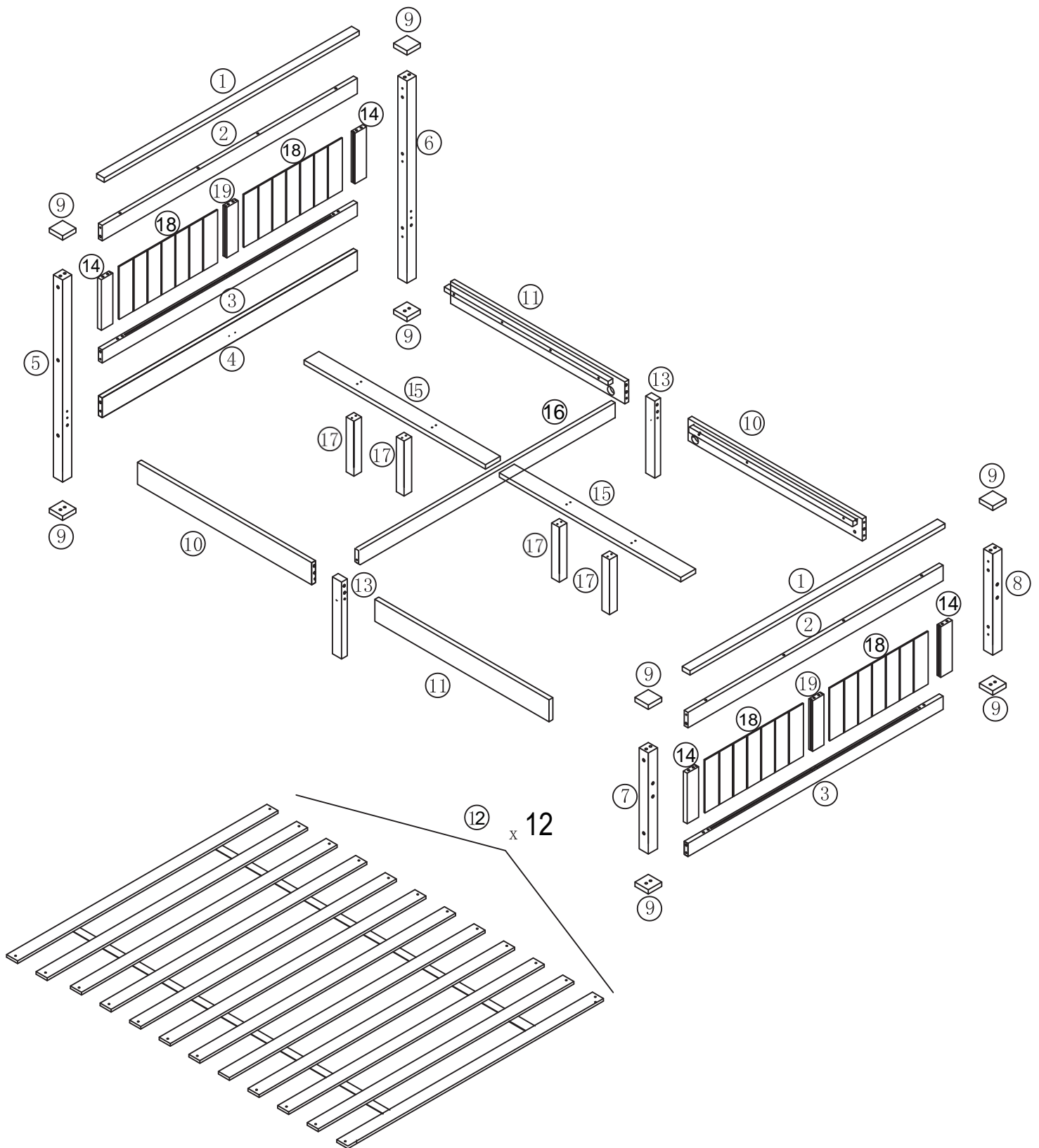



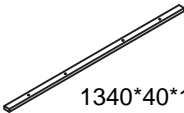
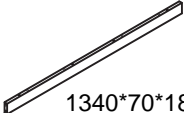
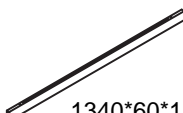
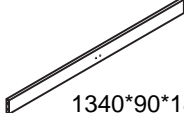





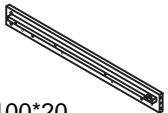
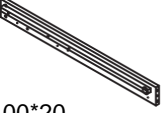



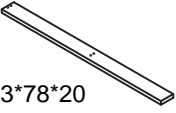
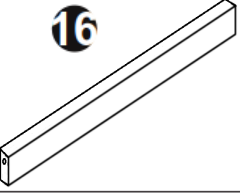

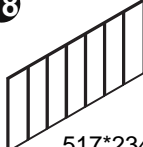



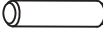

- 1.This product is designed for home use and not intended for commercial use.
- 2.This product contains small components. Please ensure that they are kept away from small children.
- 3.Becareful when using power tools to assemble your furniture. Power tools may strip or damage the parts

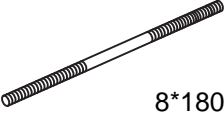
IDENTIFY PARTS

All in 1 big box!



PART LIST

| | | | | |
|--|--|---|--|---|
| <p>1</p>  <p>1340*40*18</p> <p>Headboard upper cover (x2)</p> | <p>2</p>  <p>1340*70*18</p> <p>Upper horizontal bar (x2)</p> | <p>3</p>  <p>1340*60*18</p> <p>Middle horizontal bar (x2)</p> | <p>4</p>  <p>1340*90*18</p> <p>Base cross panel(x1)</p> | <p>5</p>  <p>920*48*48</p> <p>Head left leg (x1)</p> |
| <p>6</p>  <p>920*48*48</p> <p>Head right leg (x1)</p> | <p>7</p>  <p>460*48*48</p> <p>Foot left leg (x1)</p> | <p>8</p>  <p>460*48*48</p> <p>Foot right leg (x1)</p> | <p>9</p>  <p>70*70*20</p> <p>Wood cap (x8)</p> | <p>10</p>  <p>915*100*20</p> <p>Side beams (x2)</p> |
| <p>11</p>  <p>915*100*20</p> <p>(11x2 12x2) Side beams</p> | <p>12</p>  <p>1366*60*12</p> <p>Side support bar (x1)</p> | <p>13</p>  <p>350*48*30</p> <p>Side middle support leg (x2)</p> | <p>14</p>  <p>224*60*20</p> <p>Headboard vertical bar (x4)</p> | <p>15</p>  <p>953*78*20</p> <p>Middle support beam (x2)</p> |
| <p>16</p>  <p>Middle bar(x1)</p> | <p>17</p>  <p>260*38*38</p> <p>Middle support leg (x4)</p> | <p>18</p>  <p>517*234*5</p> <p>Core board (x4)</p> | <p>19</p>  <p>224*60*20</p> <p>Headboard vertical bar (x2)</p> | |
| <p>A</p>  <p>6*90</p> <p>Screw (x18)</p> | <p>B</p>  <p>6*13</p> <p>Self-locking nut (x18)</p> | <p>C</p>  <p>10*50</p> <p>Wood dowel (x24)</p> | <p>D</p>  <p>8*30</p> <p>Wood dowel small (x24)</p> | <p>E</p>  <p>4*40</p> <p>L self-tapping screw (x4)</p> |
| <p>F</p>  <p>3*25</p> <p>M self-tapping screw (x24)</p> | <p>G</p>  <p>8*180</p> <p>Connecting rod (x2)</p> | <p>H</p>  <p>M8</p> <p>Crescent washer (x4)</p> | <p>J</p>  <p>M8</p> <p>Nut (x4)</p> | <p>K</p>  <p>4L</p> <p>Allen Key (x1)</p> |
| <p>L</p>  <p>13</p> <p>Wrench (x2)</p> | <p>M</p>  <p>20*20</p> <p>Hole cover (x18)</p> | <p>N</p>  <p>Reverse pull buckle (x24)</p> | <p>P</p>  <p>60*20</p> <p>L-shape metal panel (x2)</p> | <p>Q</p>  <p>4*16</p> <p>S self-tapping screw (x8)</p> |

PART LIST

Q



7*60

Small screw (x10)

R



Soundproof sticker
(x1)

ASSEMBLY STEPS

New panels & accessories needed in below step

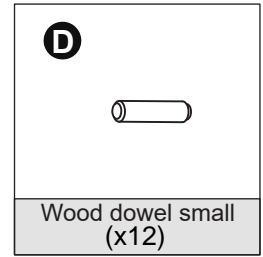
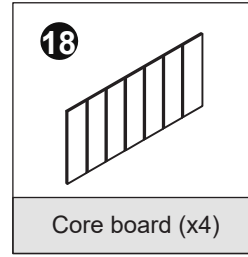
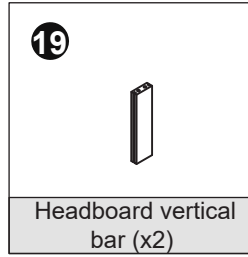
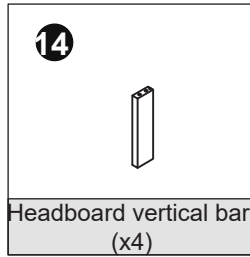
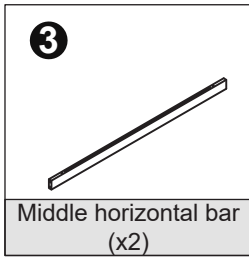

STEP 1

A. Put Headboard vertical bar(#14 ,19) insert #3 Middle horizontal bar(#14 only contains 1 side notch, while #19 has 2)And then insert #18 Core board in between bar #14 and #19 as figure shows.

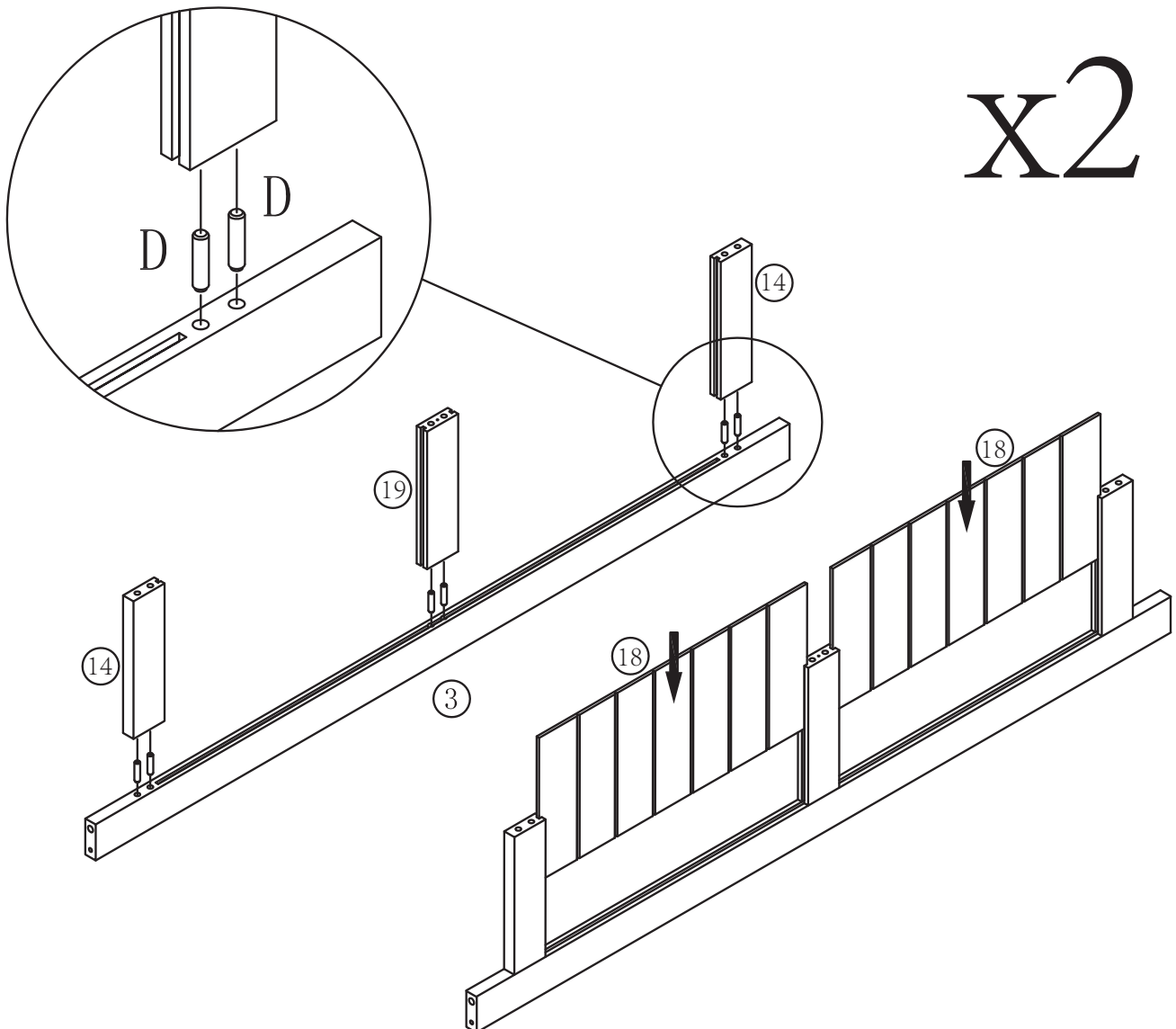

ASSEMBLY STEPS

New panels & accessories needed in below step

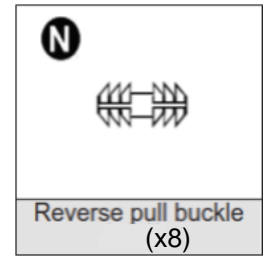
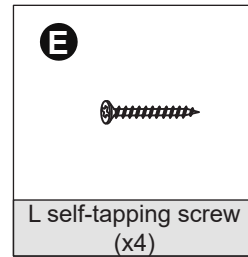
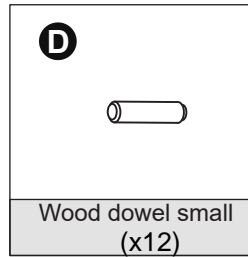
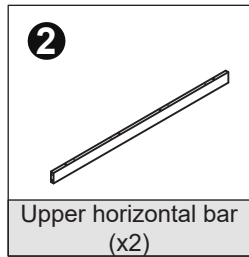
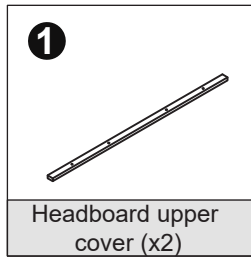

STEP2

B. Use large self-tapping screw E & small wood dowel D to fix #2 Upper horizontal bar on Headboard vertical bar (#14, #19) & #18 Core board (Tips: wood dowel (D) under bottom while screw E on the upside)

D. Fix #1 Headboard Upper Cover on #2 Upper horizontal bar (Tips: wood dowel (D) under bottom while screw E on the upside)

E. Footboard assemble step will be the same

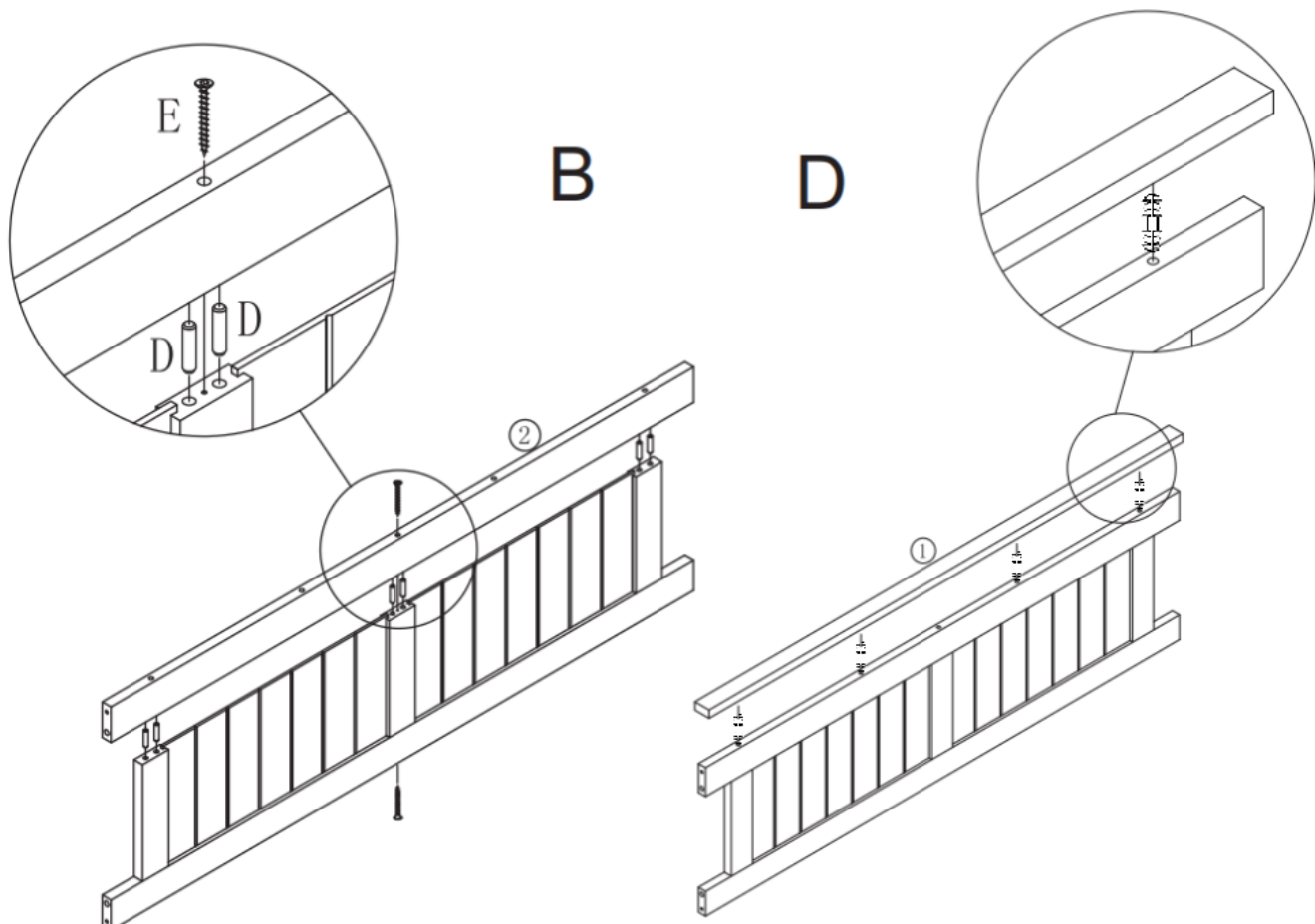

ASSEMBLY STEPS

New panels & accessories needed in below step

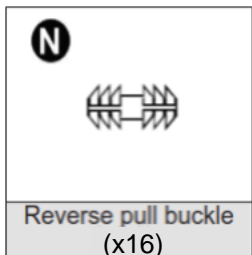
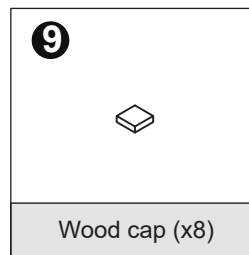
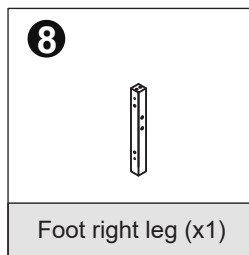
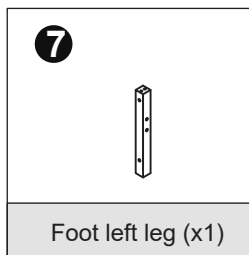
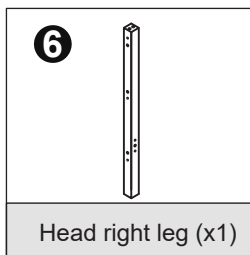
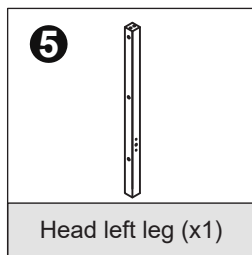

STEP3

Put wood dowel (C) insert the 2 end of bed corner legs (#5, 6, 7, 8) with glue (N), and then put #9 Wood cap on

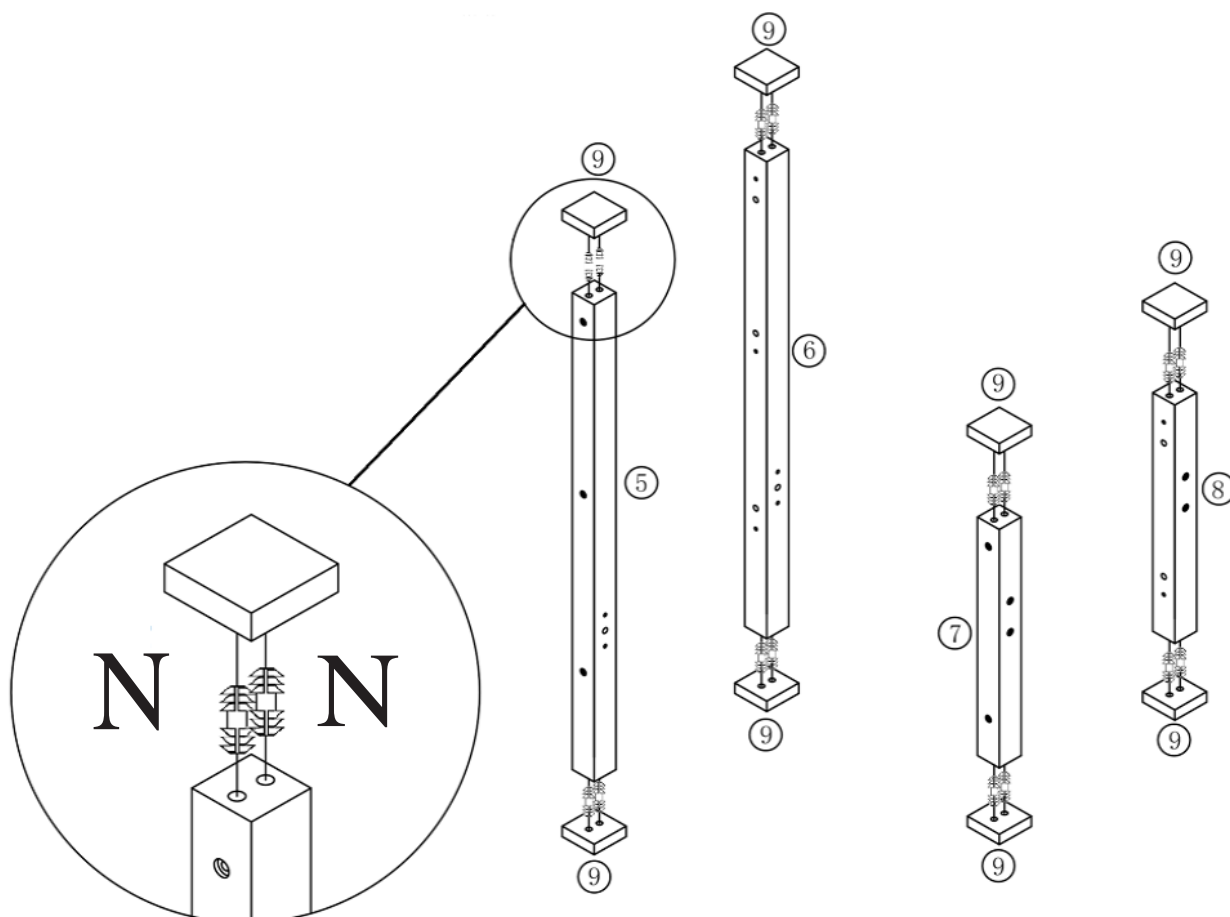

ASSEMBLY STEPS

New panels & accessories needed in below step

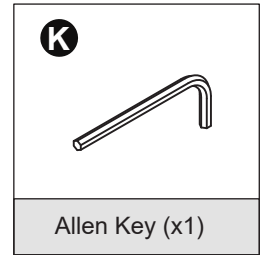
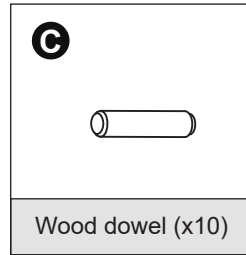
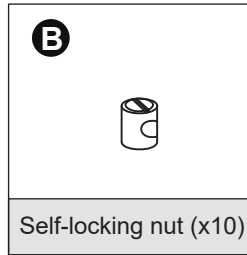
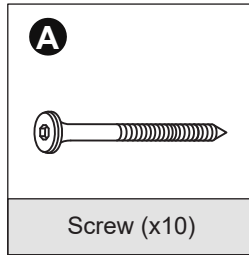
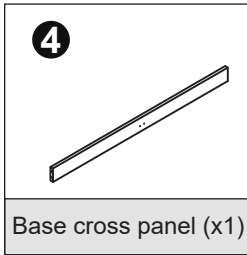

STEP4

Fix each bed corner legs (#5, 6, 7, 8) to the headboard and footboard according to the position of holes on it or the figure on IDENTIFY PARTS page

The headboard panel will need to added #4 headboard base cross panel at the same time as below figure

Methods: After figure out each position, put wood dowel (C) insert the side hole of headboard or footboard panel, and then put Self-locking nut (B) in upper hole horizontally, insert Screw (A) through the hole, and finally tight the Self-locking nut (B) to fix bed legs with the headboard or footboard panel

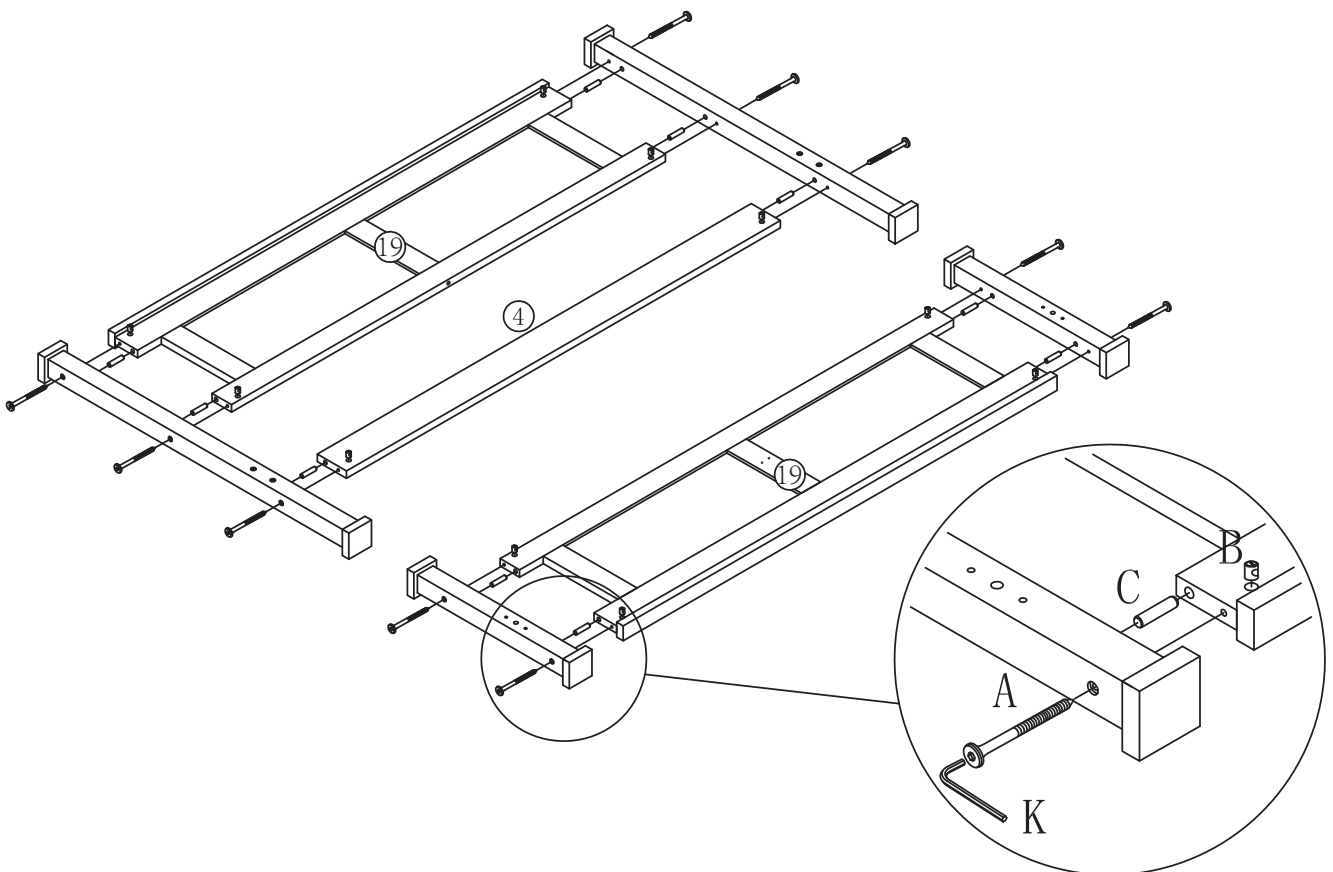

ASSEMBLY STEPS

New panels & accessories needed in below step

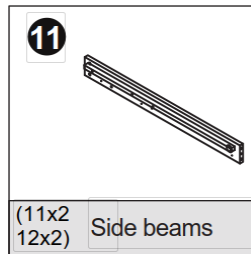
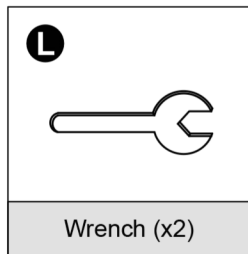
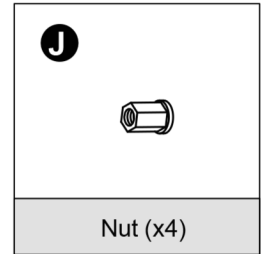
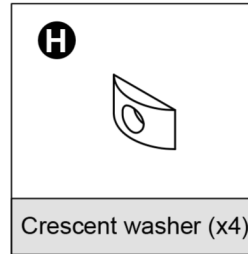
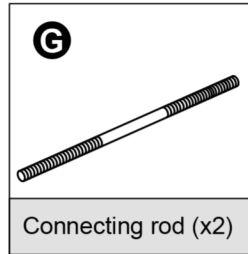
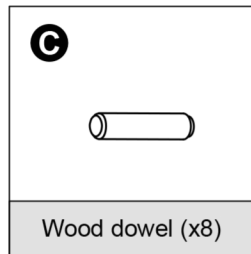
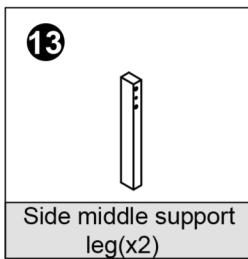

STEP6

Insert Connecting rod (G) and wood dowel (C) on #13 Middle support leg first, and then put on Side beams (#10,11) tight them by Crescent washer (H) and Nut(J) with the helping of Wrench L

(Tips: the #12 Side support bar on left And right Side beams should be in same level, and the #13 Middle support leg should be keep same level with inner side of bed side beams, in order to put on wood slat smoothly)

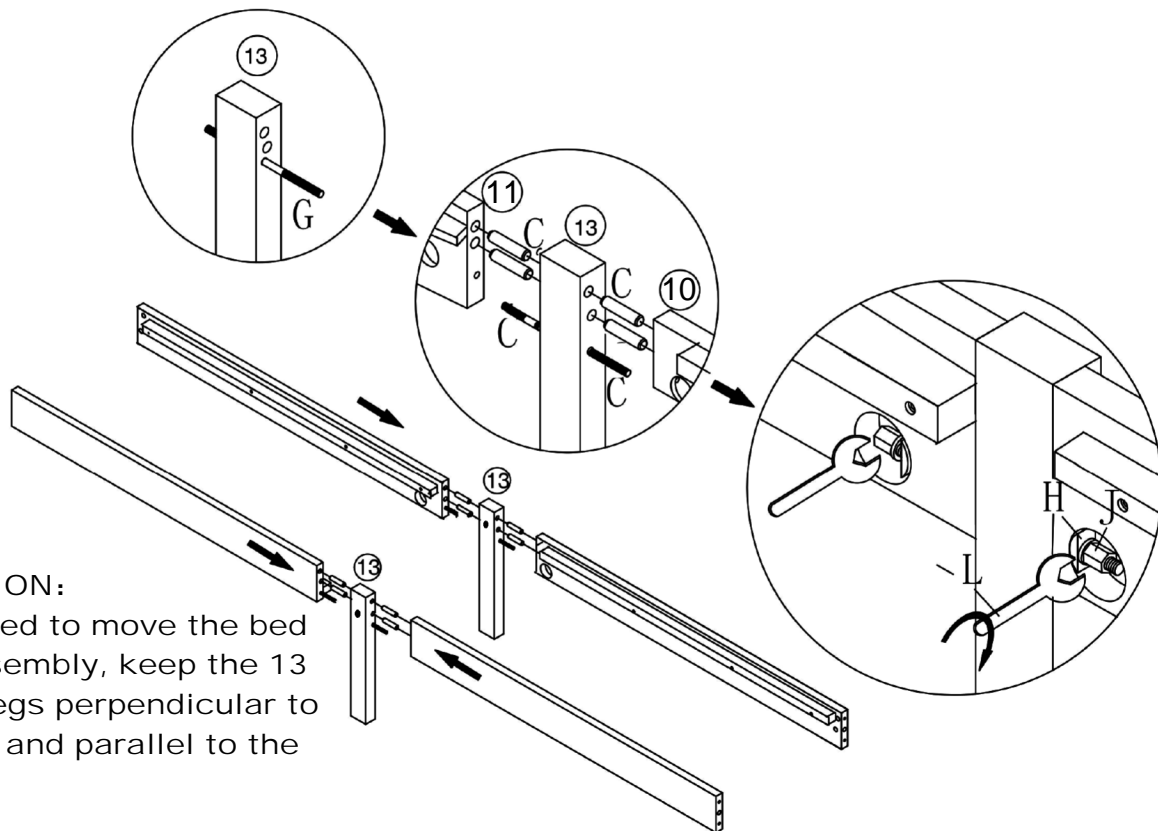

ATTENTION:

If you need to move the bed after assembly, keep the 13 middle legs perpendicular to the floor and parallel to the bed?

ASSEMBLY STEPS

New panels & accessories needed in below step

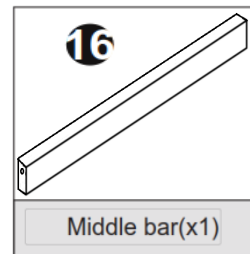
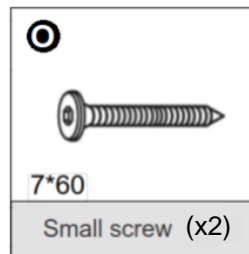
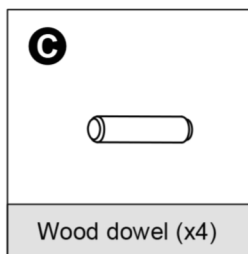
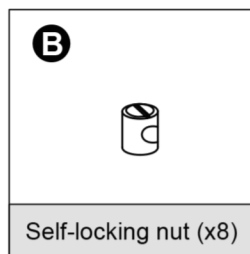
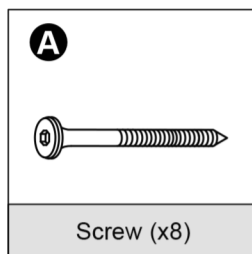

STEP 7

Put assembled bed side together with headboard and footboard

Methods: Fix one Side beams with the headboard first: put wood dowel (C) insert the side hole of headboard, and then insert 2 pcs of Self-locking nut (B) on the inner side horizontally to fix with leg of headboard, and then put screw (A) through legs to fix bed side panel. After assembled the headboard with 2 bed side panels, using same method to connect the footboard.

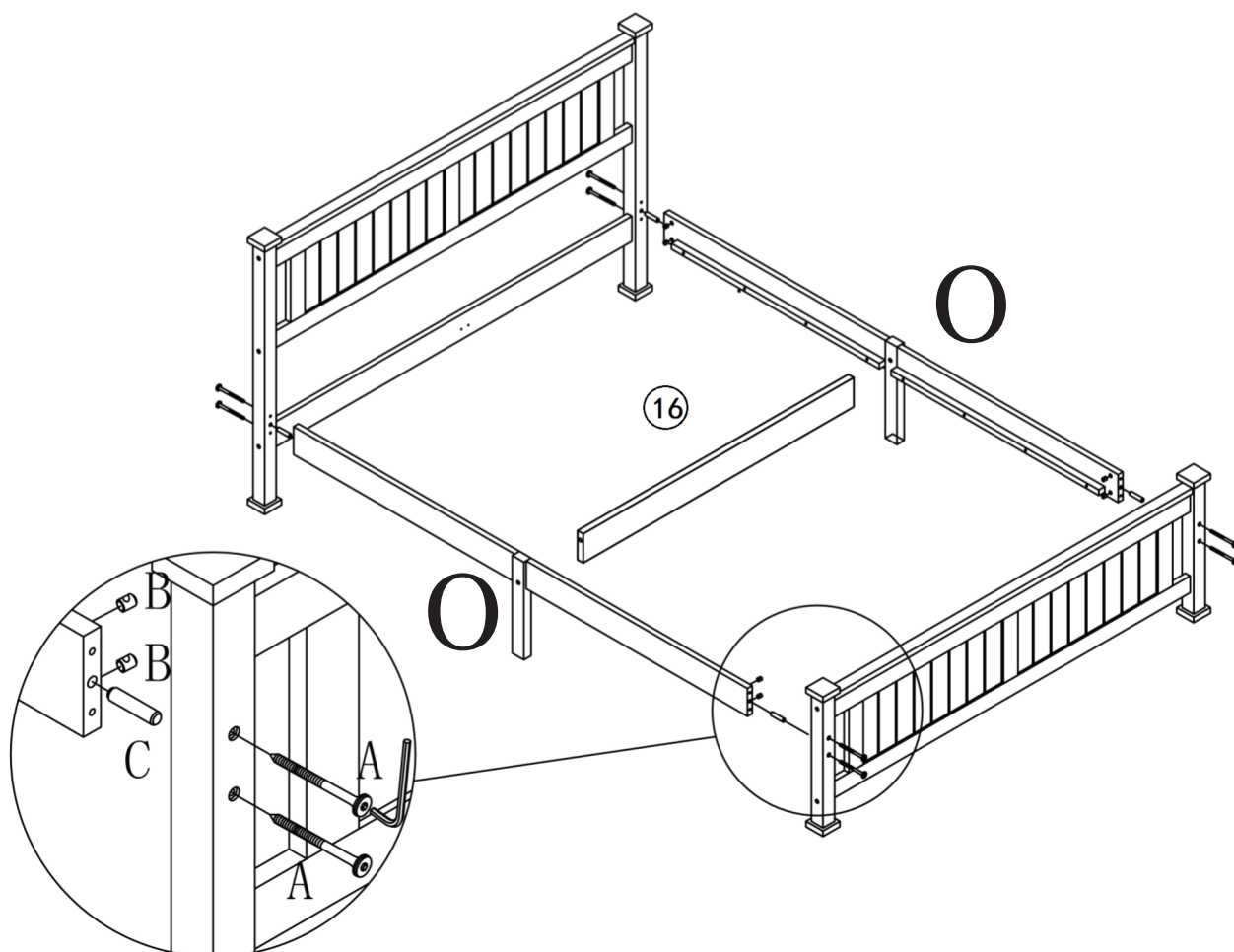

ASSEMBLY STEPS

New panels & accessories needed in below step

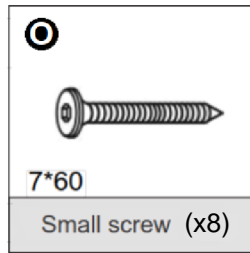
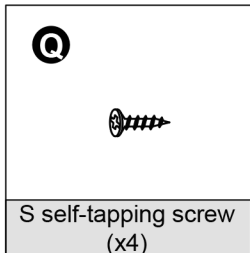
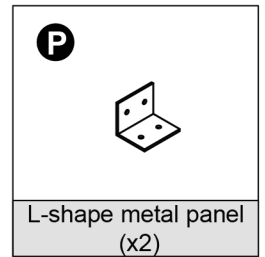
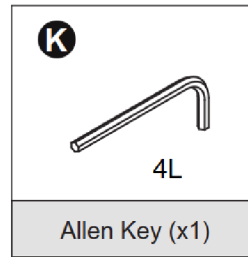
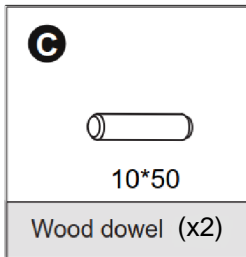
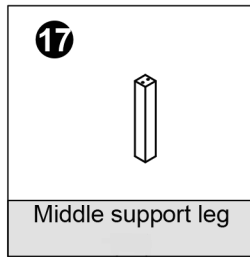
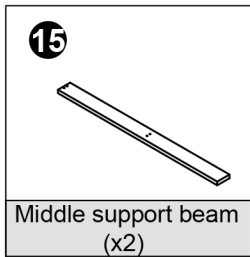

STEP8

- Fix #15 middle support beam on middle support leg(#16,17) by using self-tapping screw E
- Turn over the #15 middle support beam, and then fix L-shape metal plate P on the 2 ends of #15

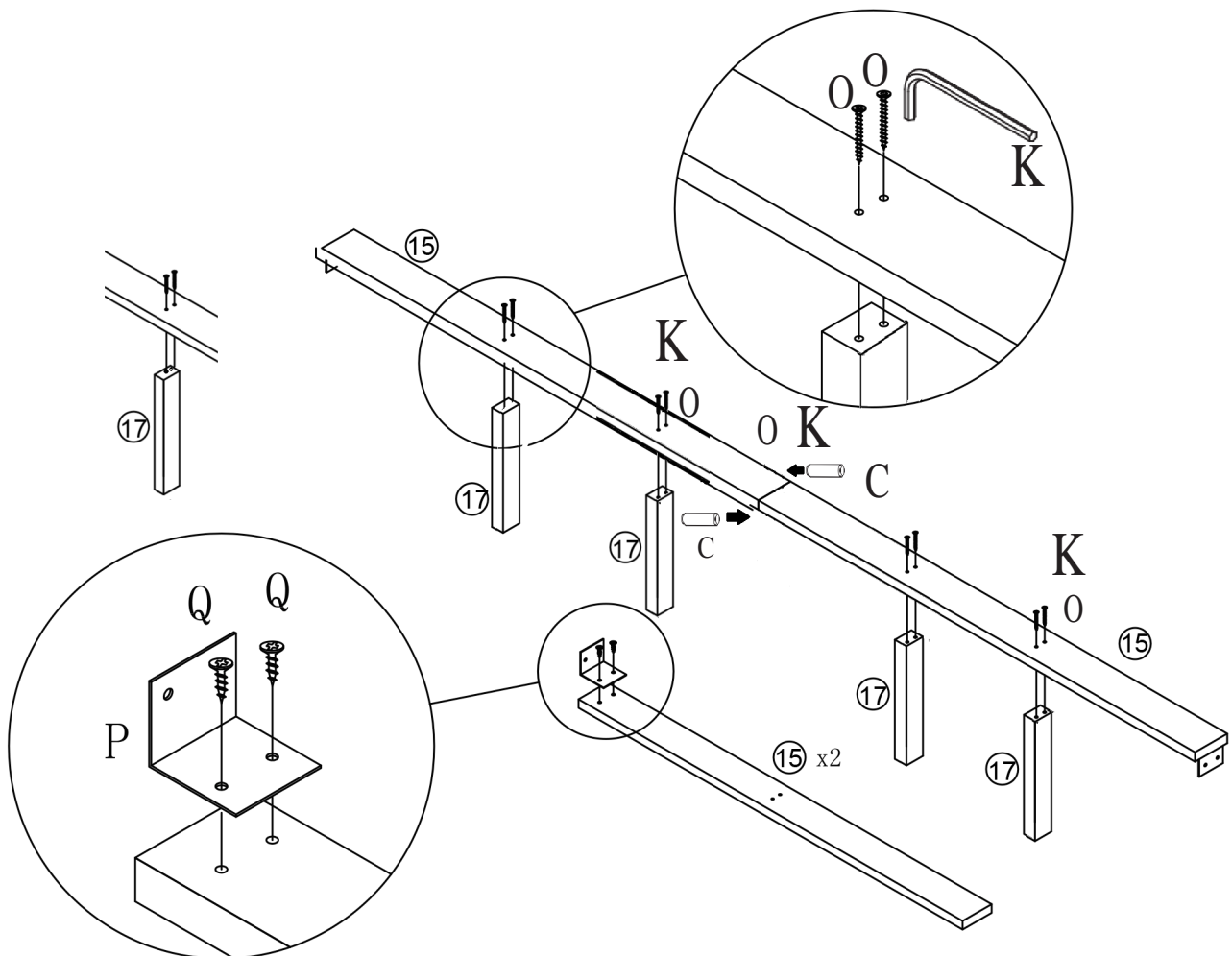

ASSEMBLY STEPS

New panels & accessories needed in below step

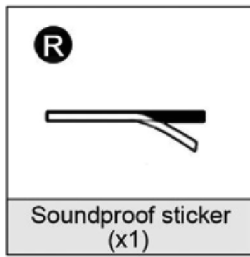
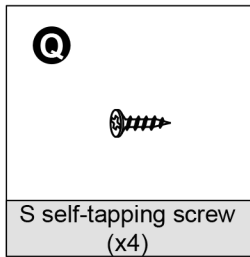

STEP 9

Fix #15 middle support beam with headboard and footboard by using self-tapping screw Q through L-shape metal plate P

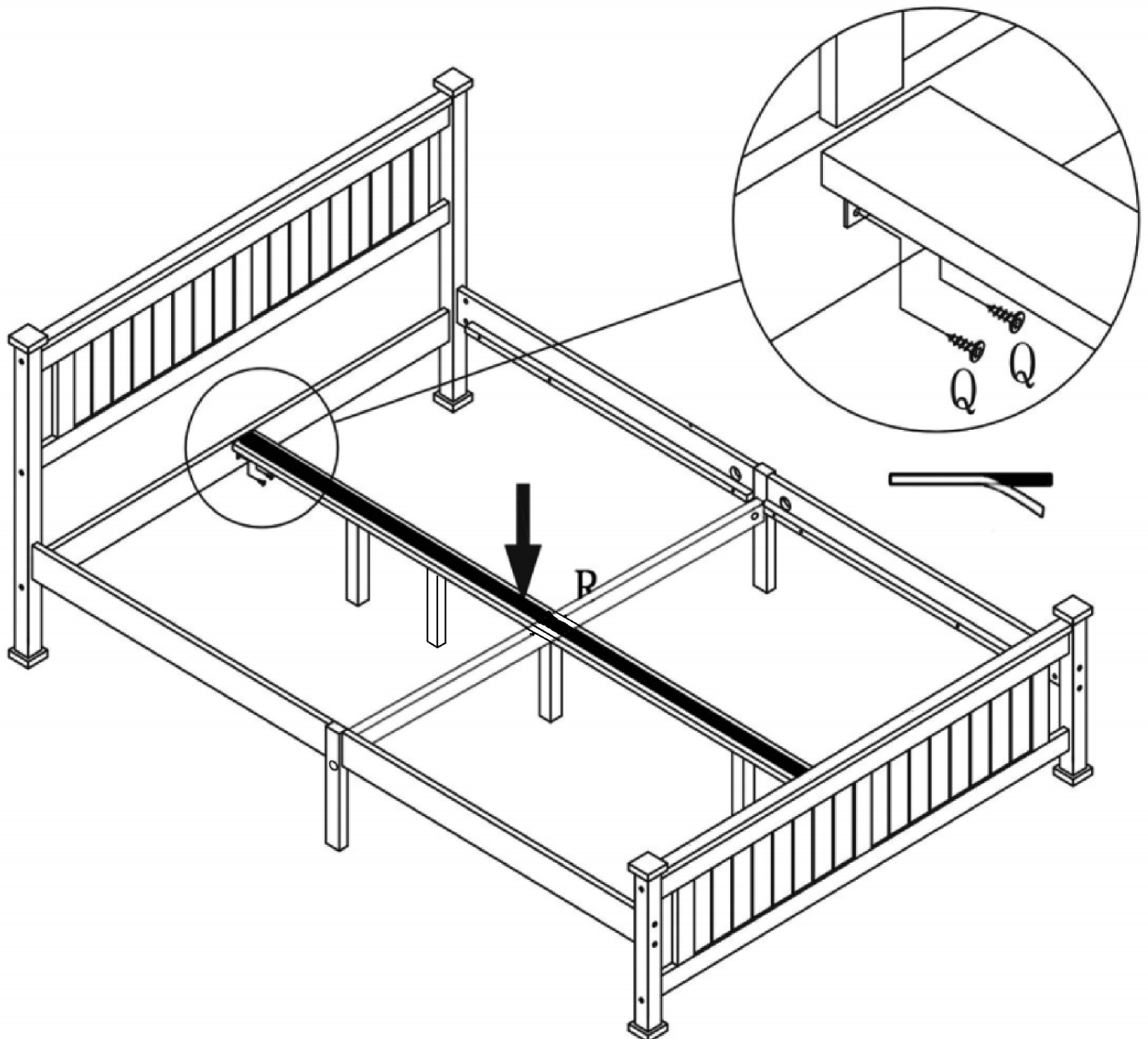

ASSEMBLY STEPS

New panels & accessories needed in below step

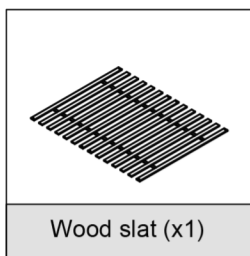

Wood slat (x1)

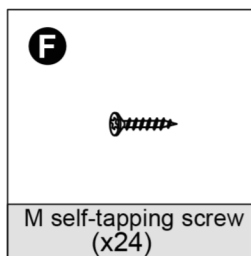

M self-tapping screw
(x24)

STEP 10

Fix wood slat on (strips side should be underneath) with self-tapping screw (F)

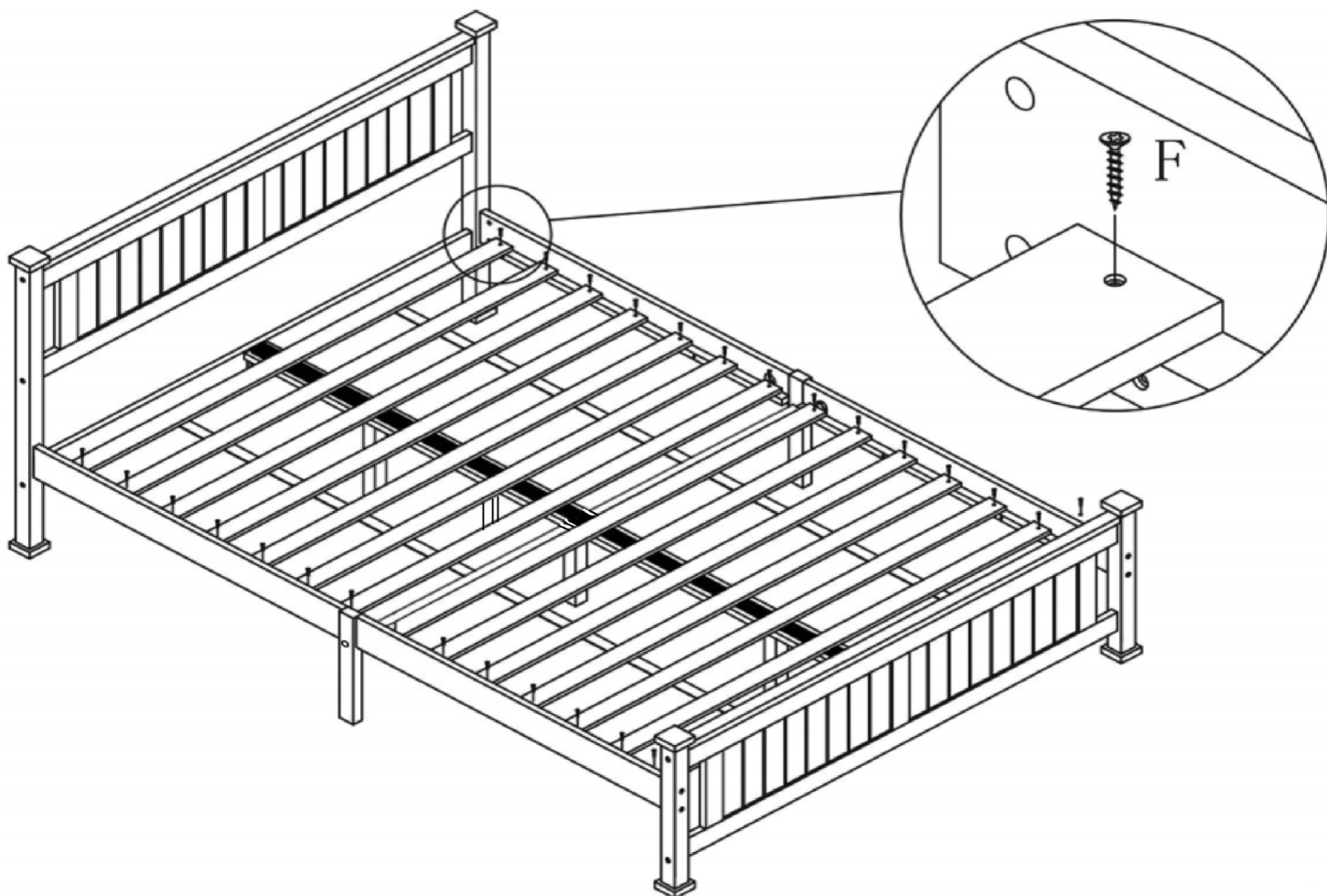

ASSEMBLY STEPS

New panels & accessories needed in below step

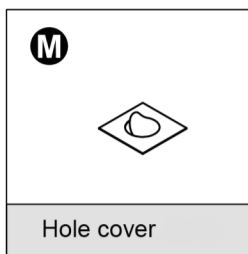

STEP11

To make the product more beautiful, paste Hole cover (M) on all the exposed screw holes.

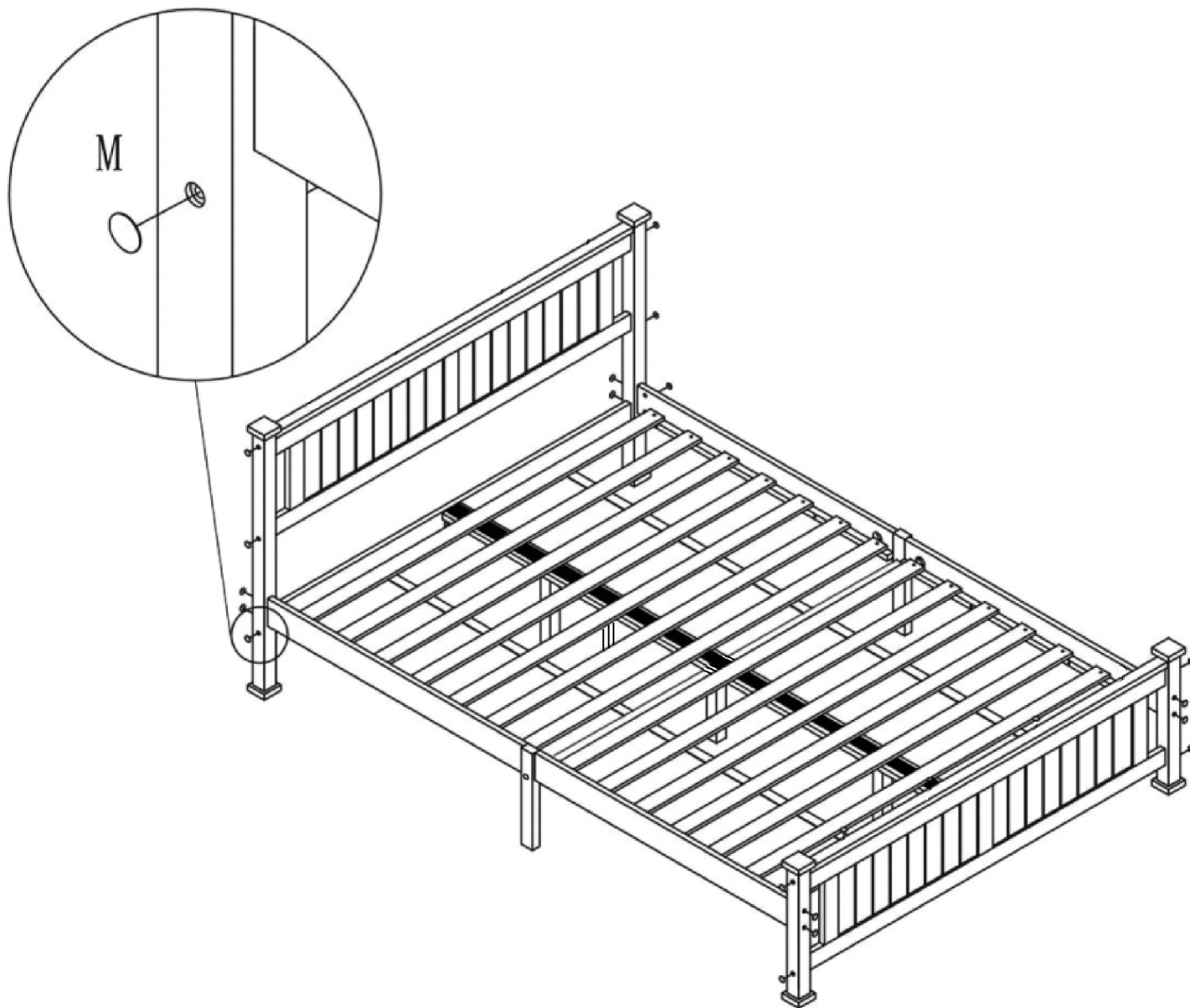

MAXIMUM LOADS

This unit has been designed to support the maximum loads shown. Exceeding these load limits could cause sagging instability, collapse, and serious injury.

Full Load-bearing:
440.92lb / 200kg

Queen Load-bearing:
551.16lb / 250kg

