

Assembly Instructions

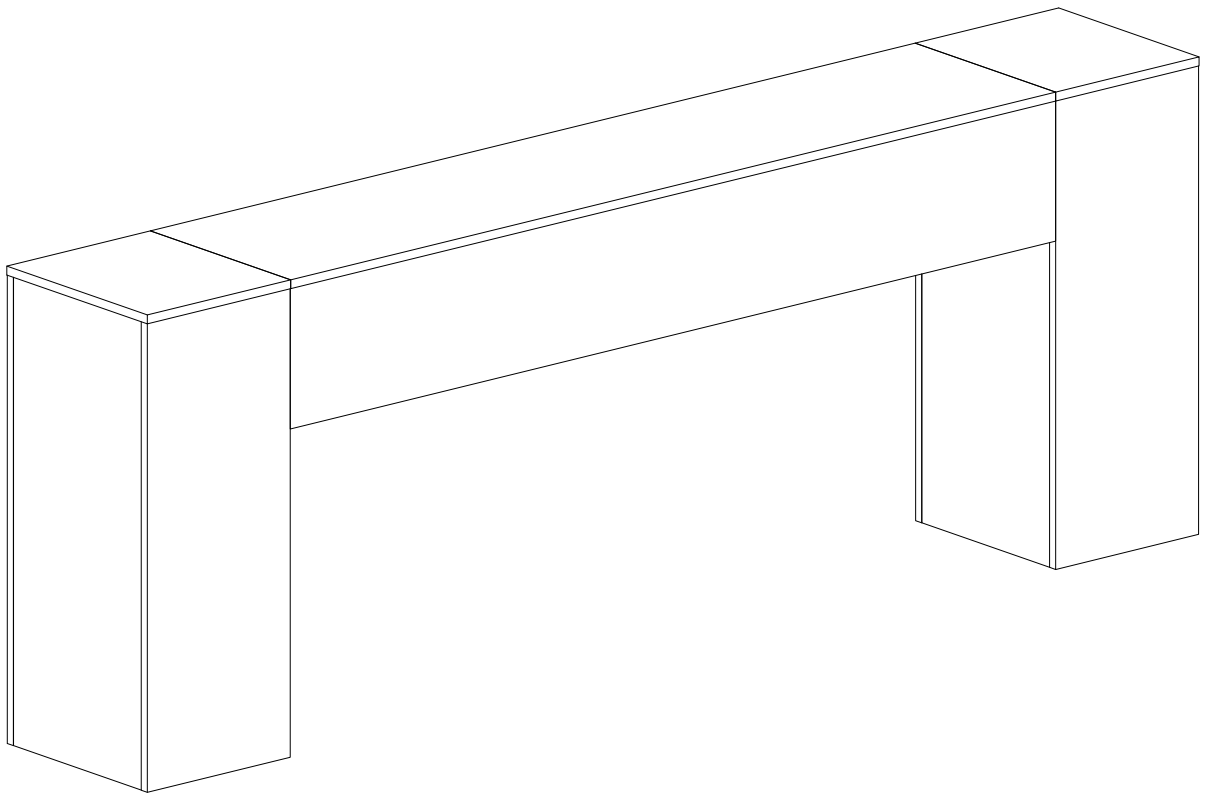

Model No. ZL-ZY0079

Contact Us

We're here to help you.



Your satisfaction is our top priority. If you encounter any issues with this product, such as missing or damaged parts, we're here to help. Please retain the original packaging and take photos of the packaging and the product, then contact us as soon as possible.

Email: support@epecoya.com

Warm Tips

1. Carefully read these instructions and keep them for future reference.
2. Check the parts list and confirm everything's there before starting assembly.
3. When assembling, put all parts on a soft, smooth surface like a carpet to avoid scratches.
4. Don't fully tighten screws until all parts are confirmed in place to avoid misalignment.

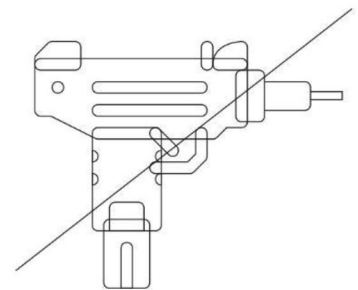
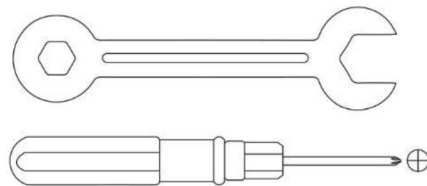
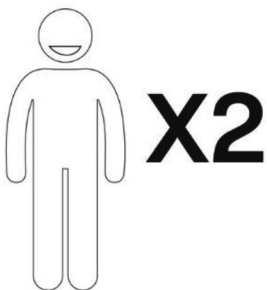

We recommend using hand tools for assembly.

If an electric screwdriver is used, reduce power and torque to avoid damage to the product.

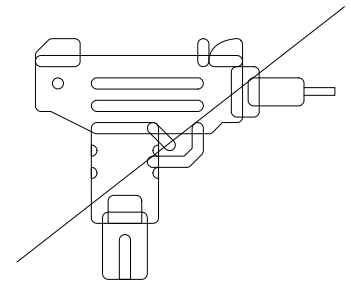
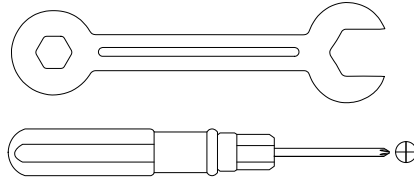
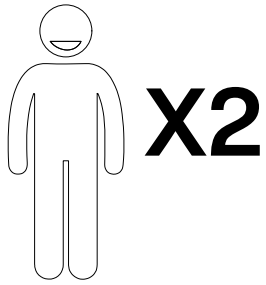

We recommend using hand tools for assembly.

If an electric screwdriver is used, reduce power and torque to avoid damage to the product.

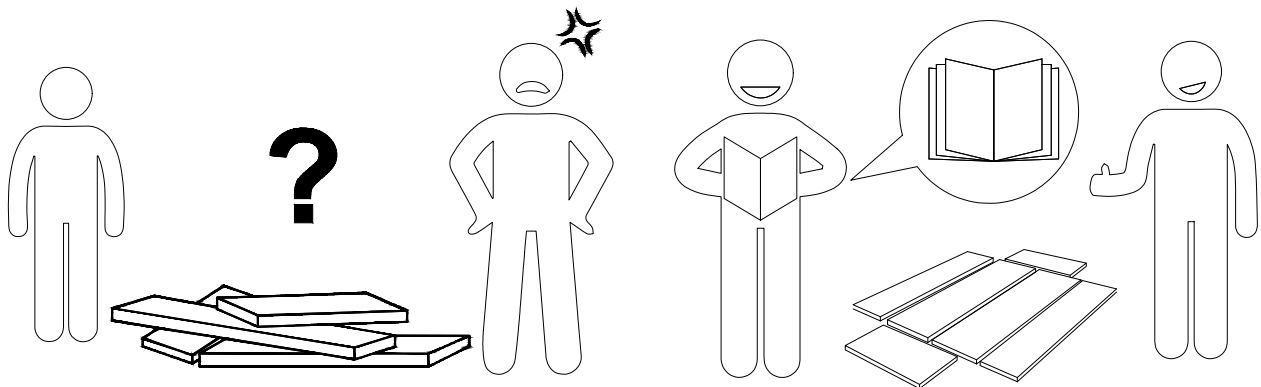

Install the Anti-Tip Straps

Using the anti-tip straps can reduce the risk of tipping over, but can not eliminate it.

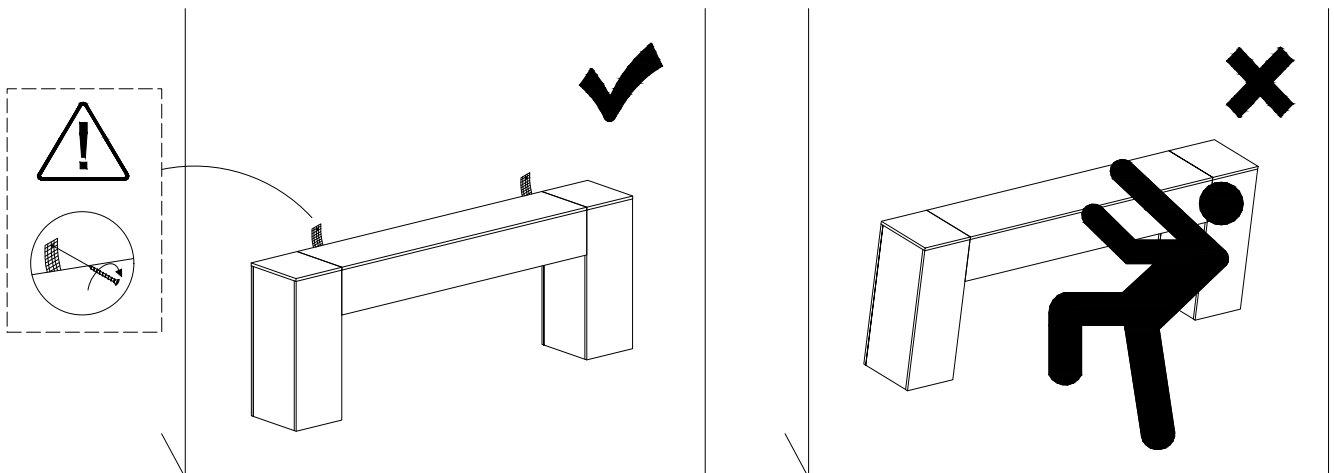

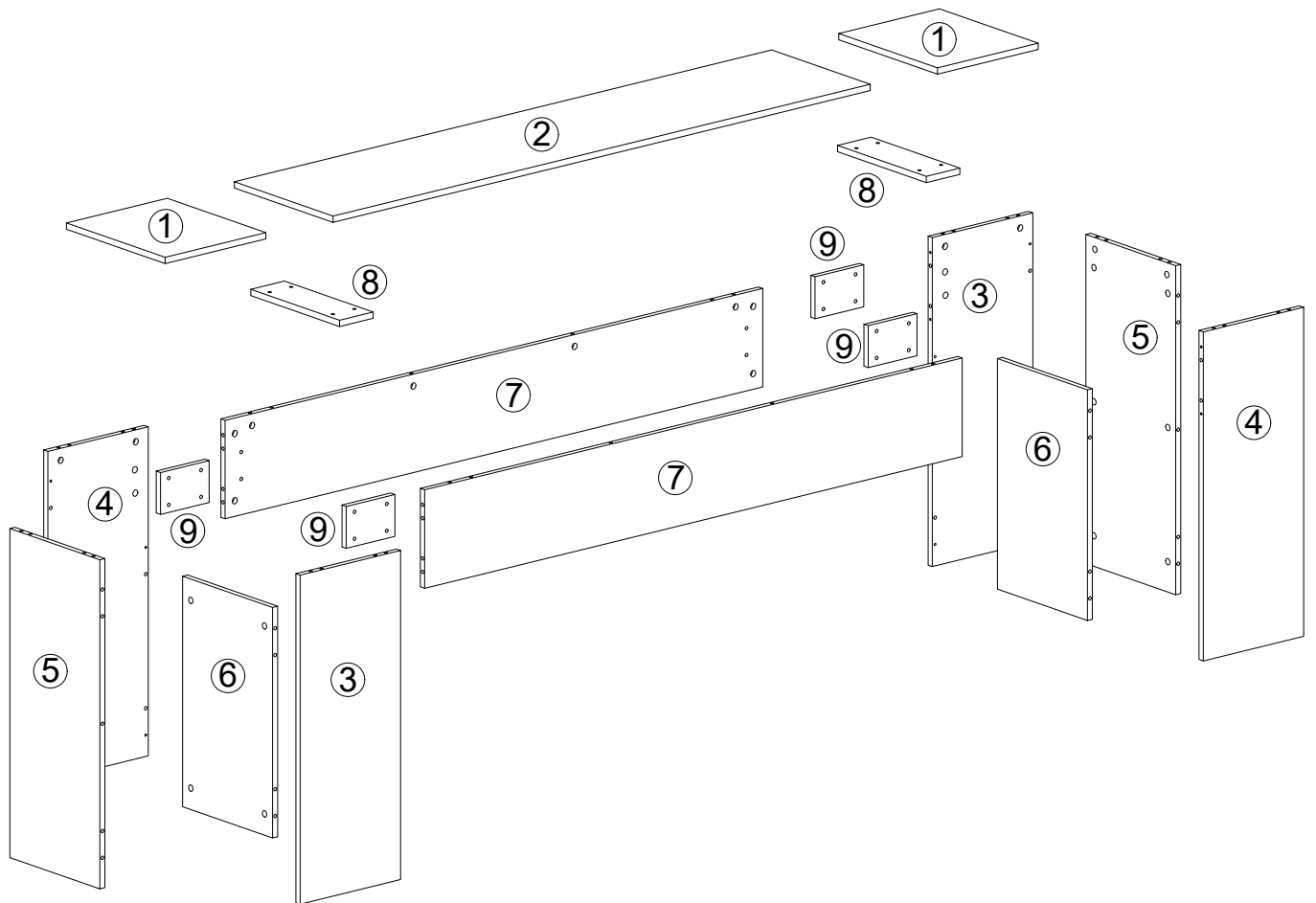





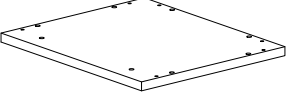
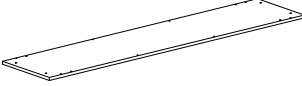
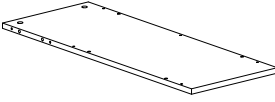
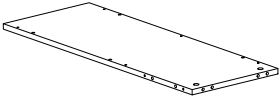
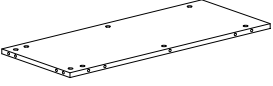
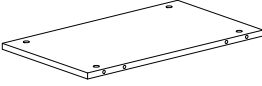
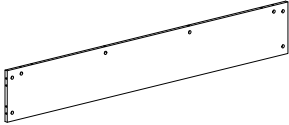
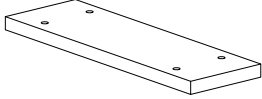
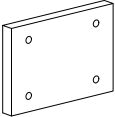

Caution

Make sure all parts are included. Most board parts are labeled or stamped on the raw edge. Contact us for a free replacement if you encounter any damaged or missing parts.

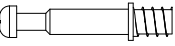
Parts List

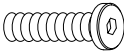
 ① 2pcs	 ② 1pc	 ③ 2pcs	 ④ 2pcs
 ⑤ 2pcs	 ⑥ 2pcs	 ⑦ 2pcs	 ⑧ 2pcs
 ⑨ 4pcs			

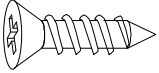
Hardware List

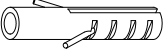
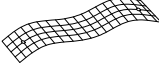
Ax48	Bx48	Cx40	Dx24	Ex1
				
Ø6X35mm	Ø15X12mm	Ø8X30mm	M6X25mm	M4X64mm
Fx2	Gx2	Hx2	Ix2	
				
Ø3.5X14mm	Ø4X35mm	Ø8X40mm	155X20mm	

Installation of Cams and Pins

Read each step carefully before starting. Each step of instruction should be performed in the correct order. If these steps are not followed in sequence, assembly difficulties may occur.

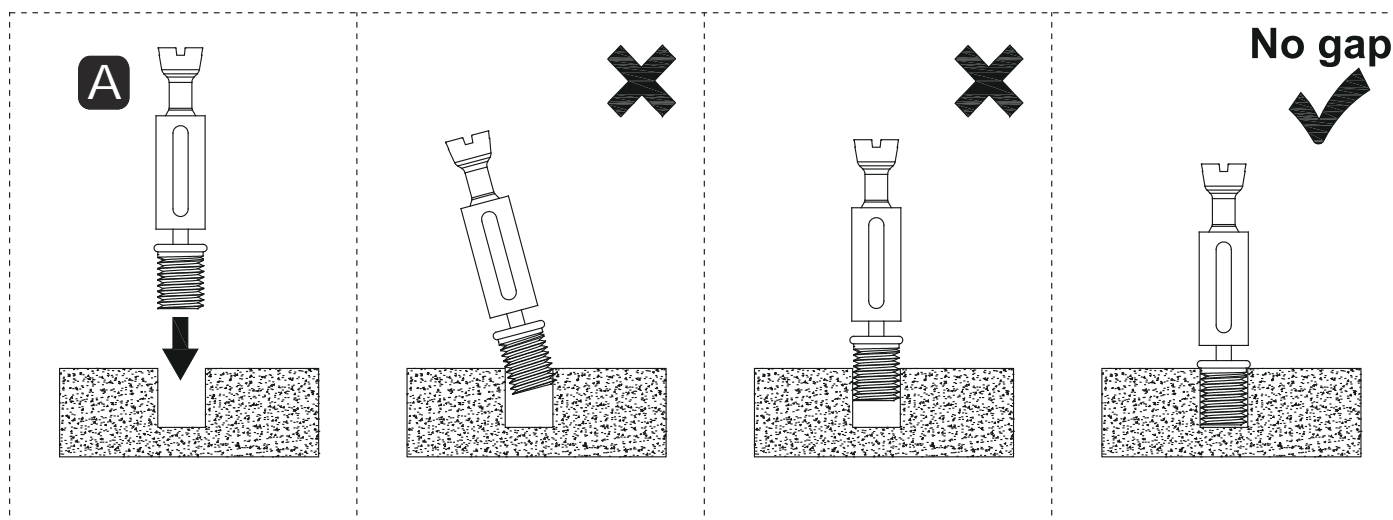
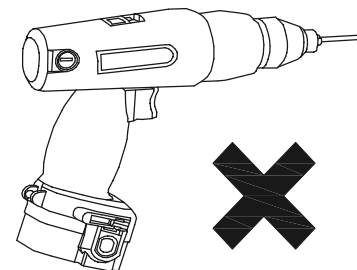

Screw the pin into the hole. Set the cams correctly by aligning the head of the cams with the lock pins. Lock the cam by turning the cam head with a screwdriver until it is tightened. Please do not use an electric screwdriver to assemble the unit.

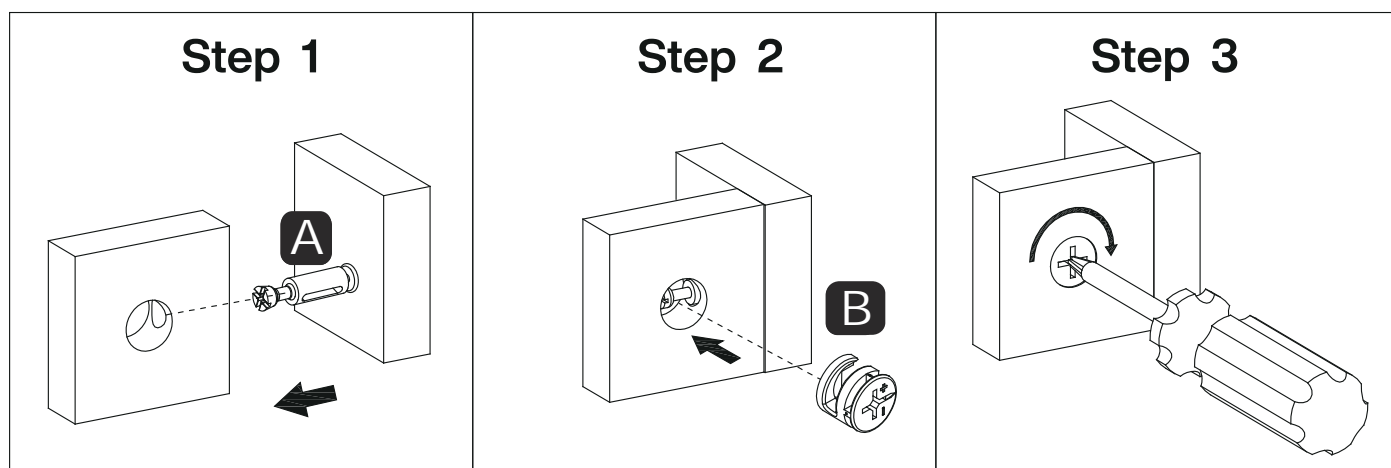

1

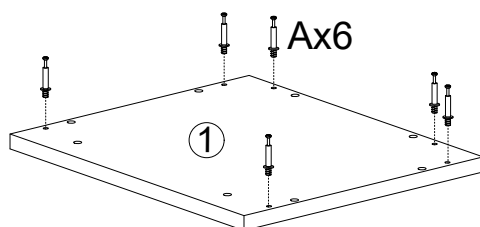
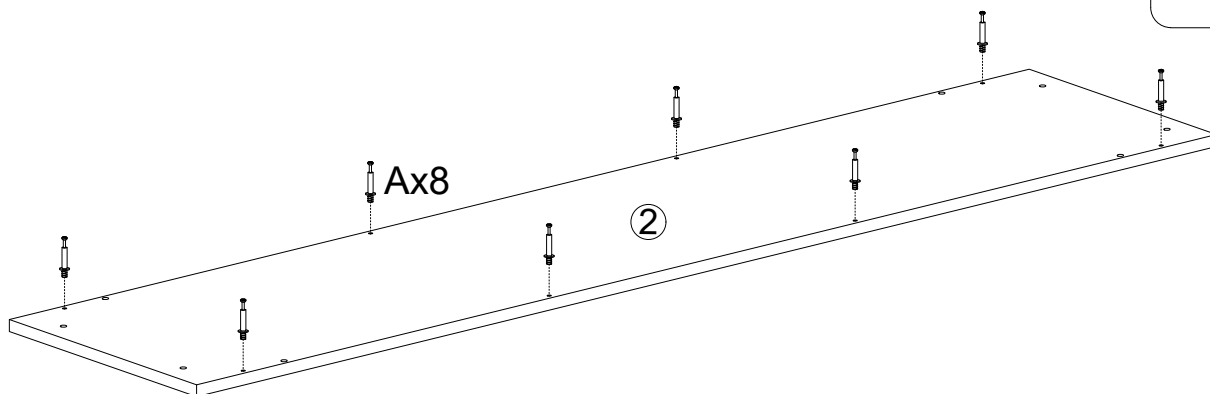
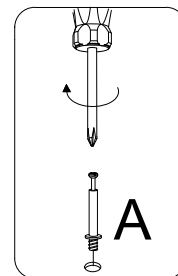

X2

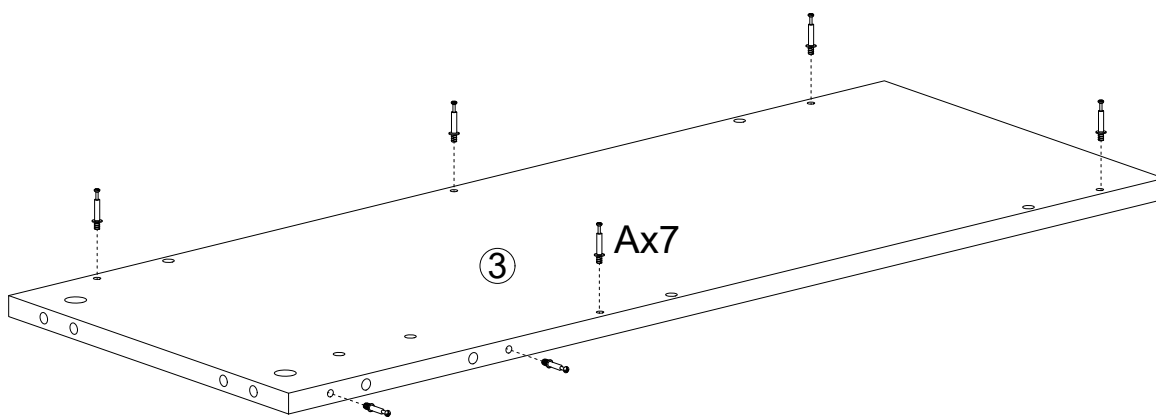

X2

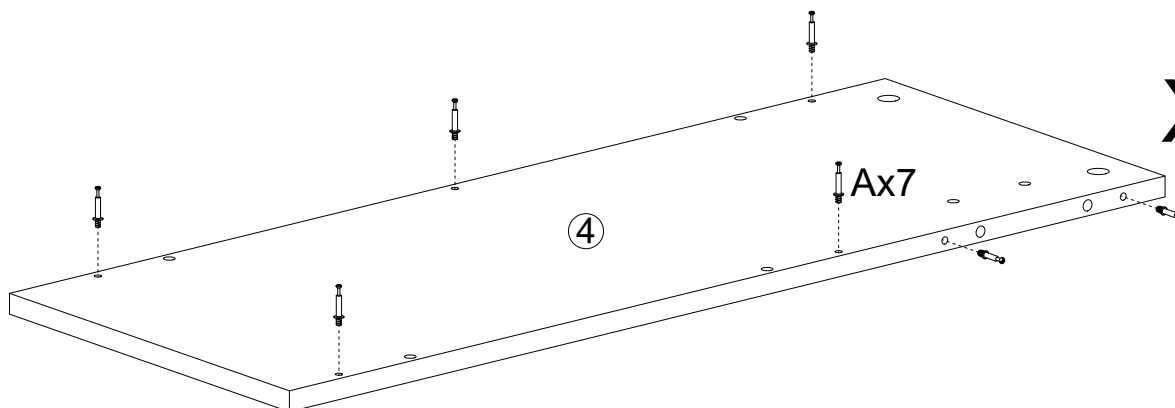

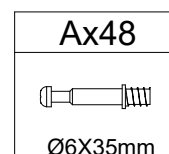

X2

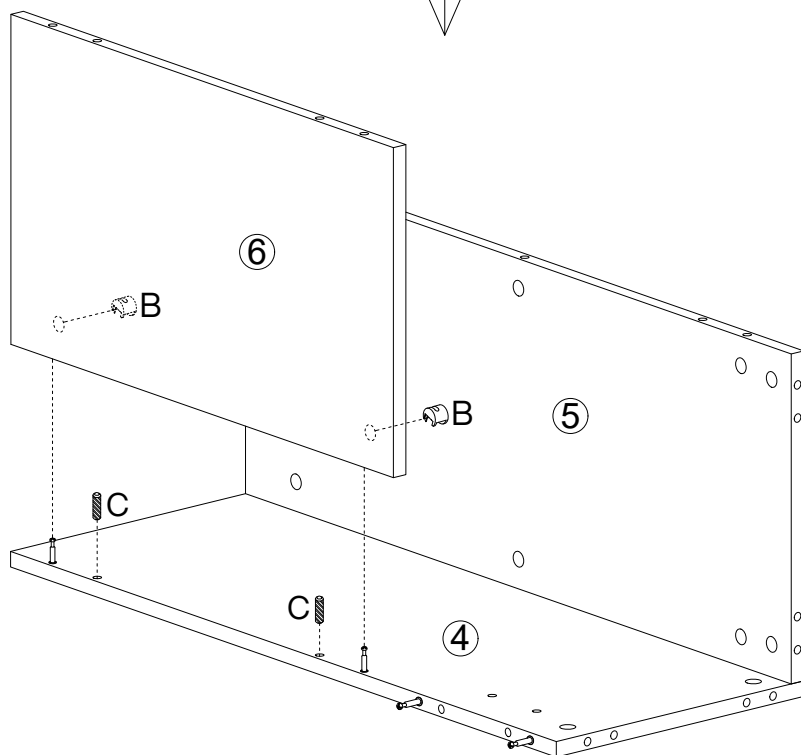
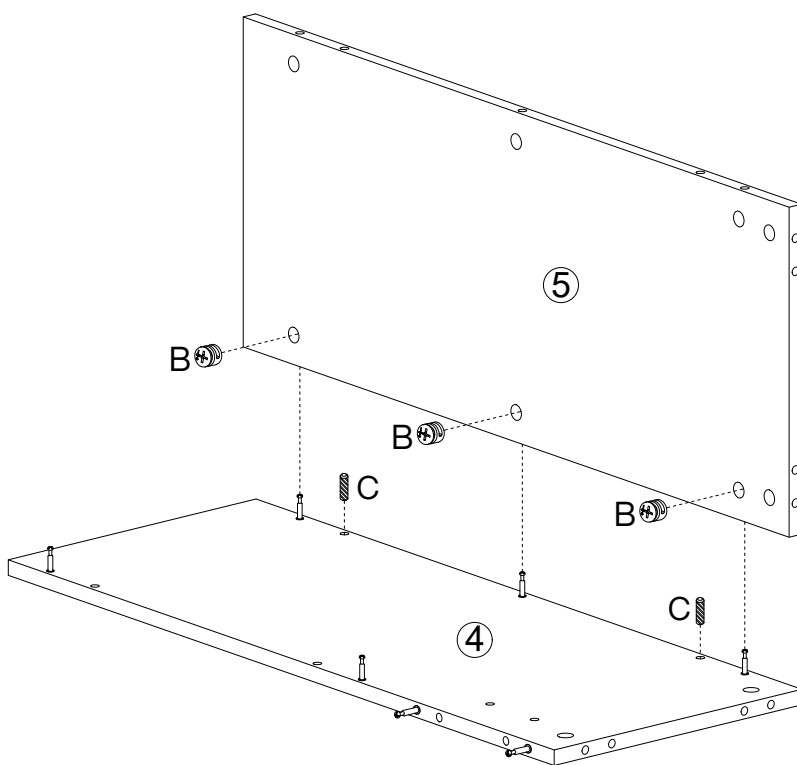

2





X2

Bx10	Cx8
	
Ø15X12mm	Ø8X30mm

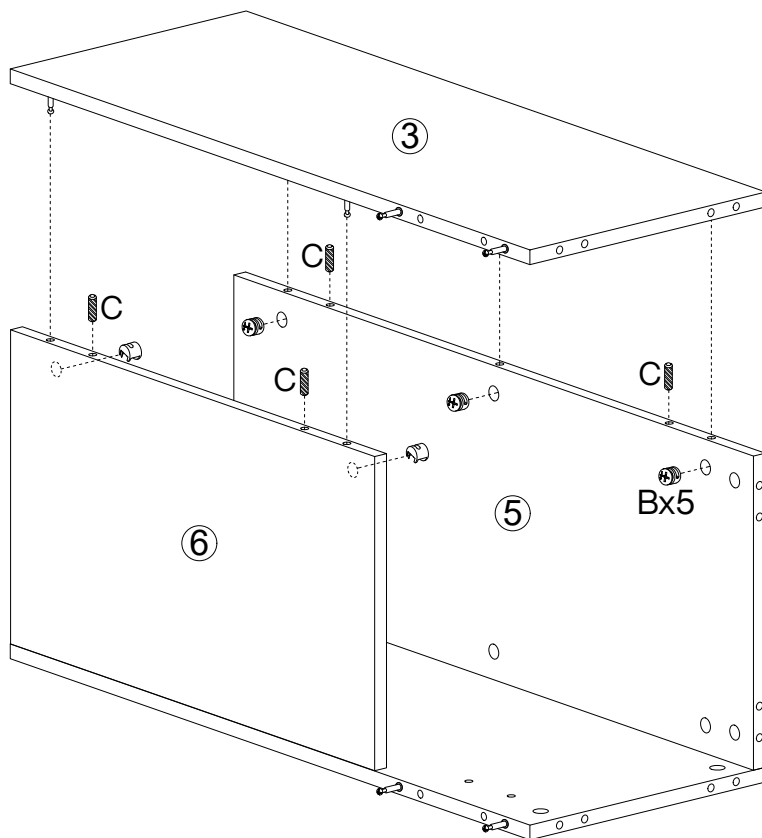
3





X2

Bx10	Cx8
	
Ø15X12mm	Ø8X30mm

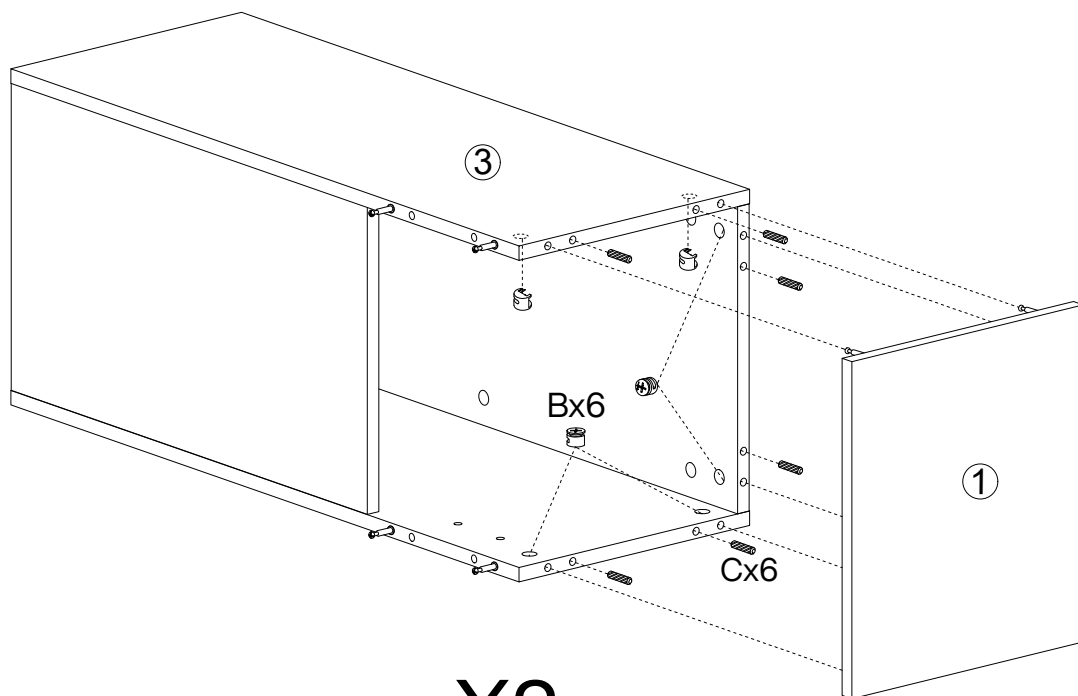
4



X2

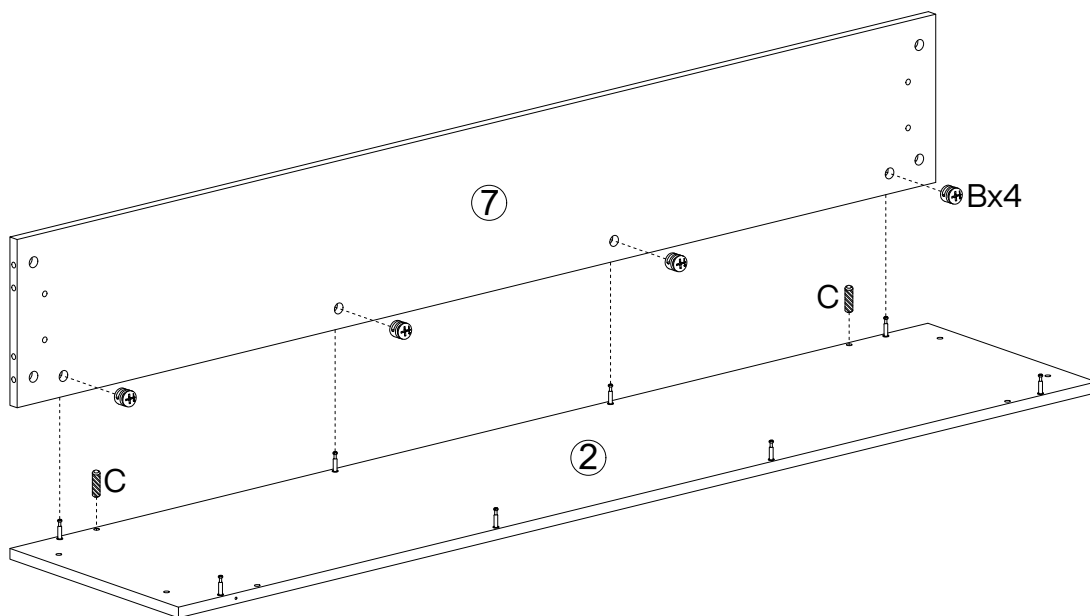

Bx12	Cx12
	
Ø15X12mm	Ø8X30mm

5



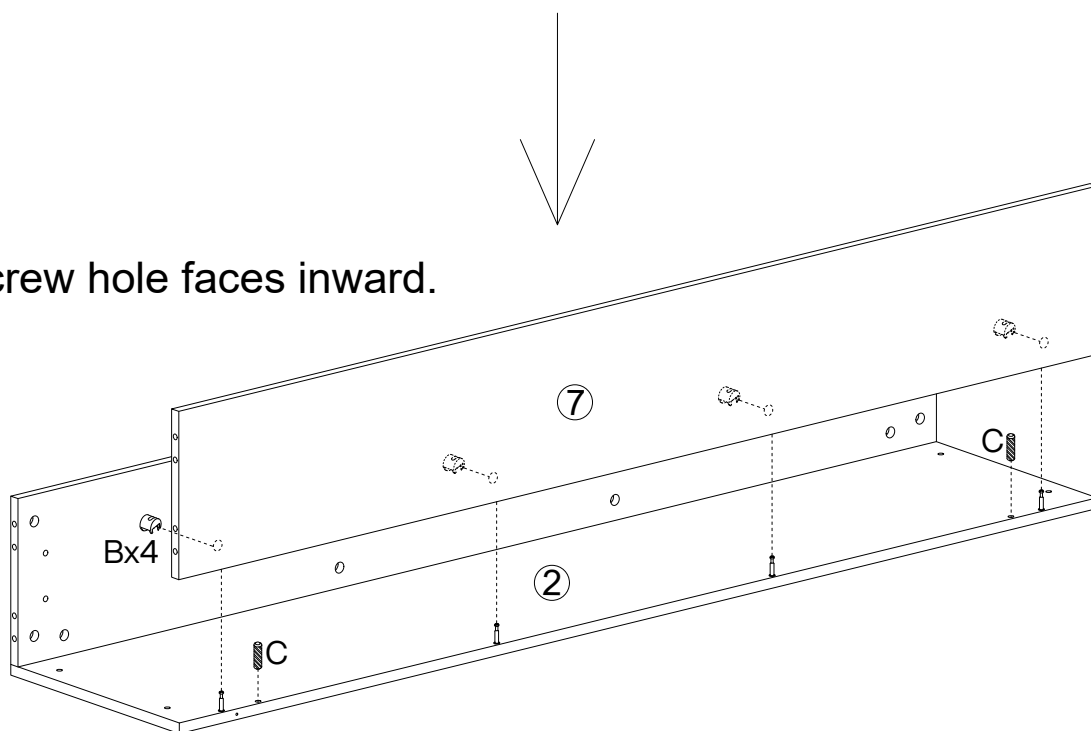

The screw hole faces inward.



Bx8	Cx4
	
Ø15X12mm	Ø8X30mm

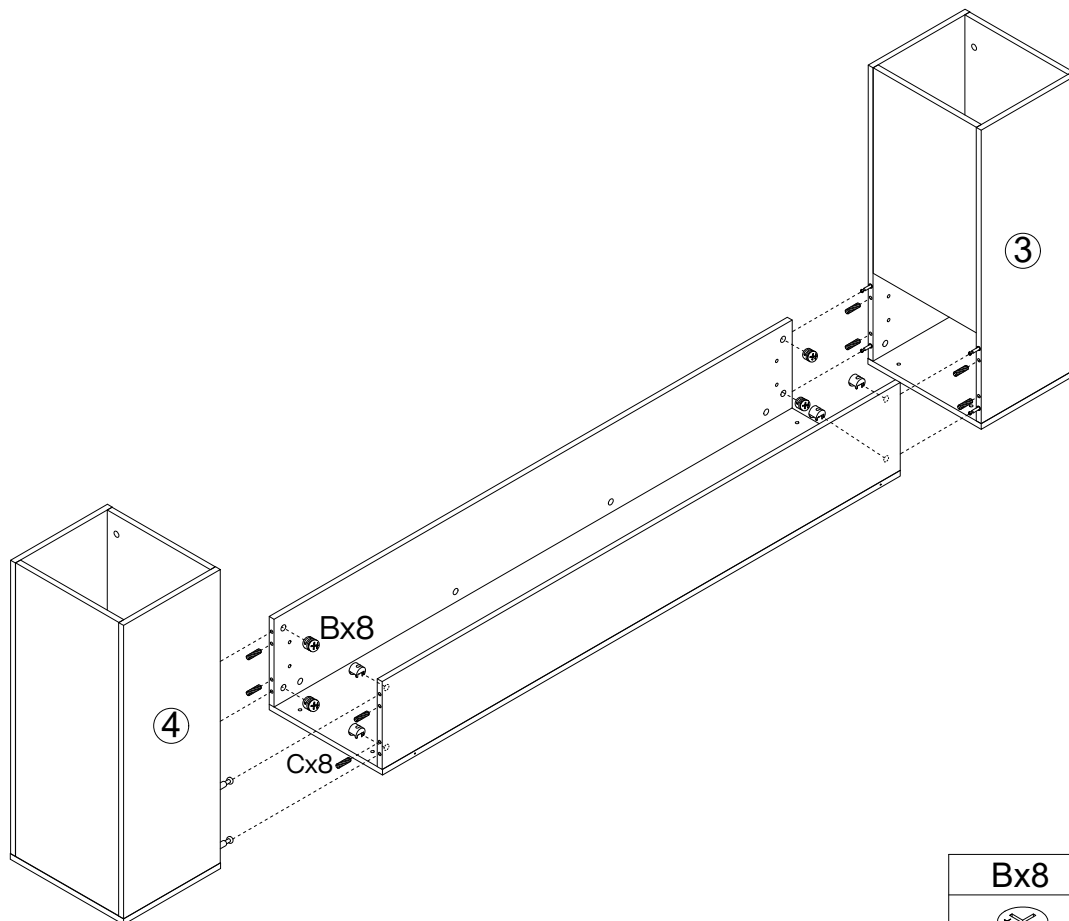

6

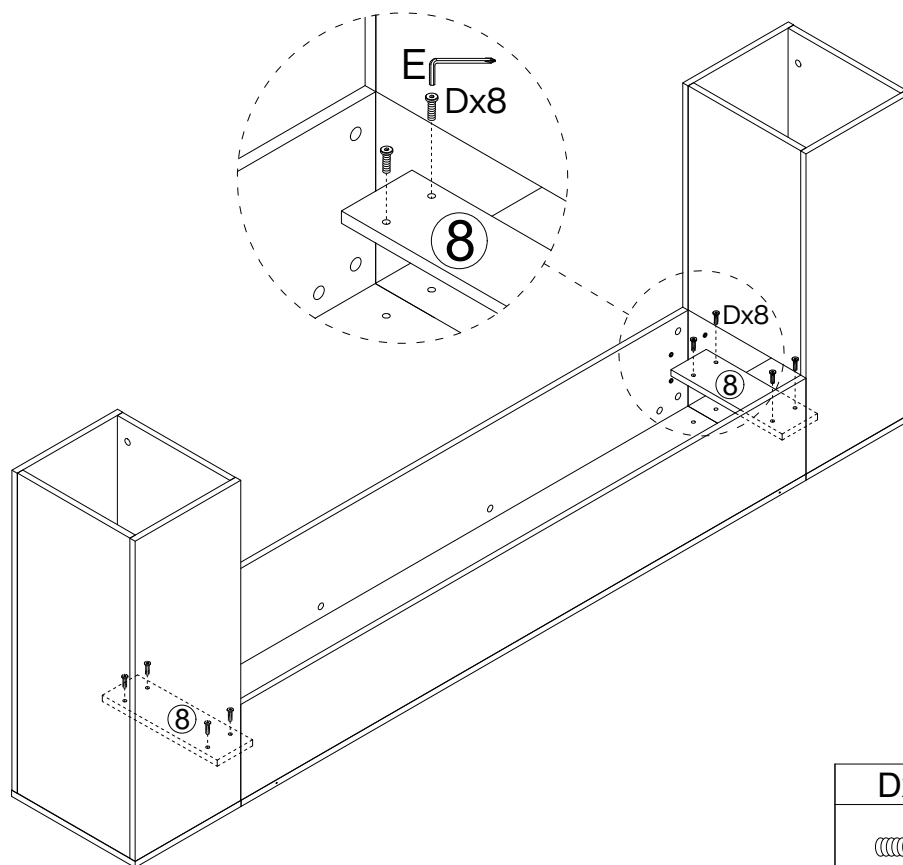

Bx8	Cx8
	
Ø15X12mm	Ø8X30mm

7



Dx8	Ex1
	
M6X25mm	M4X64mm

8

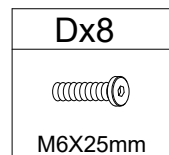
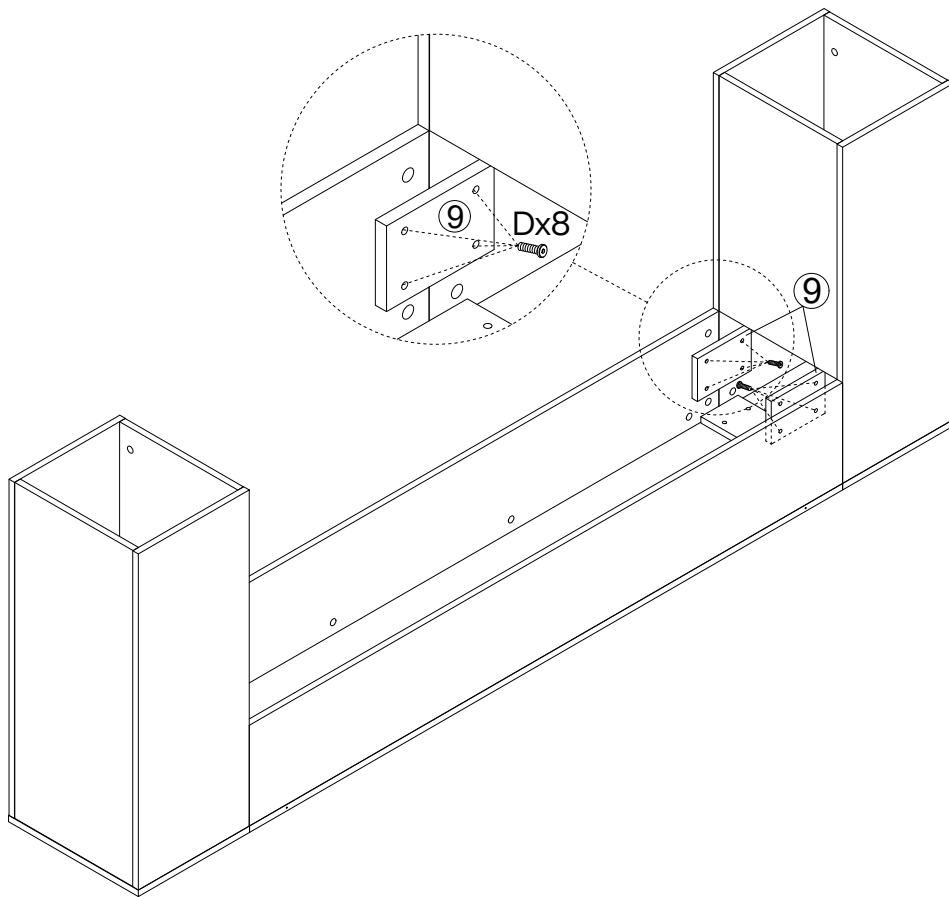

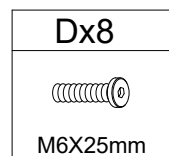
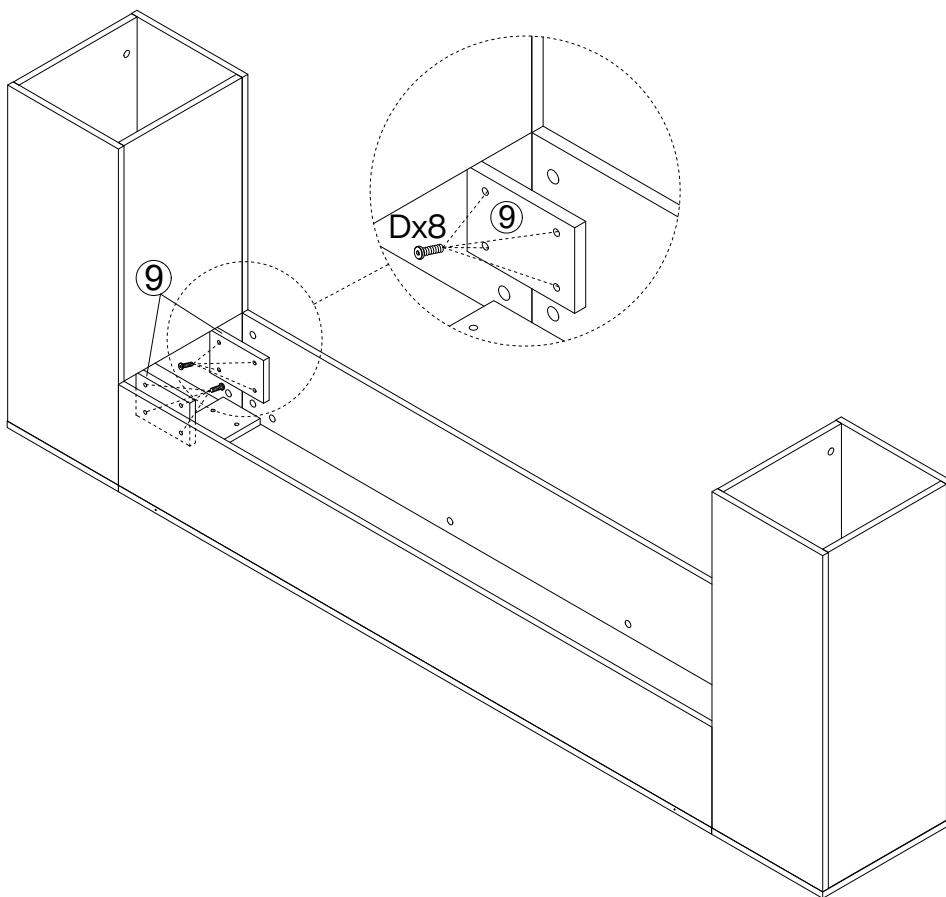

9



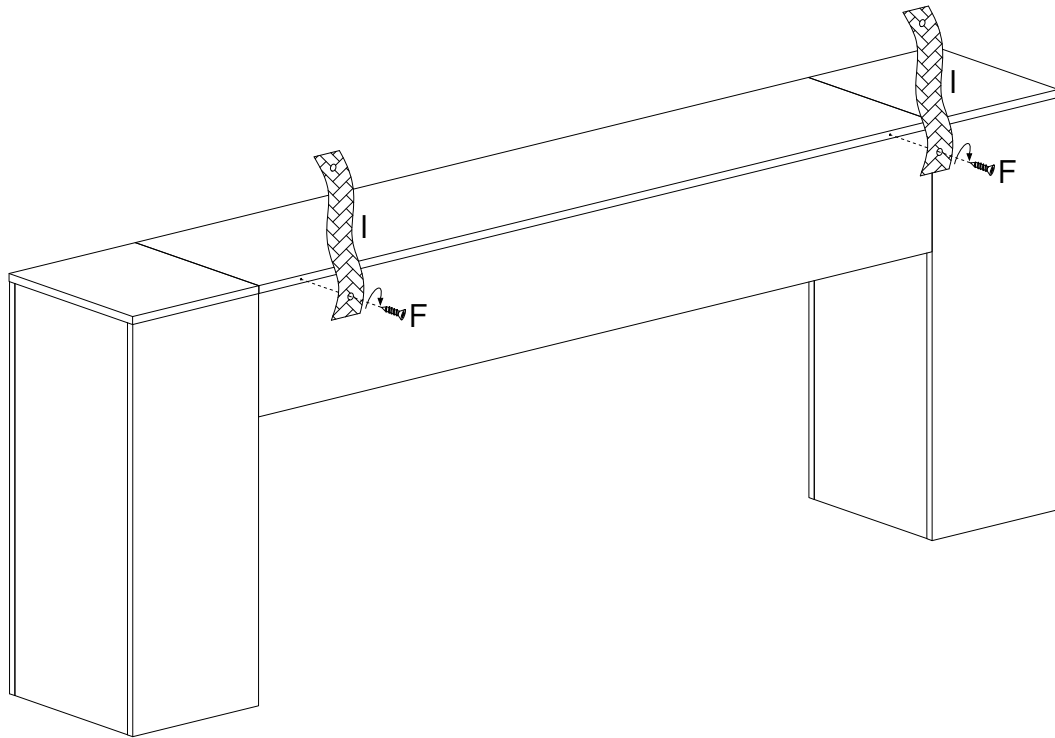

10

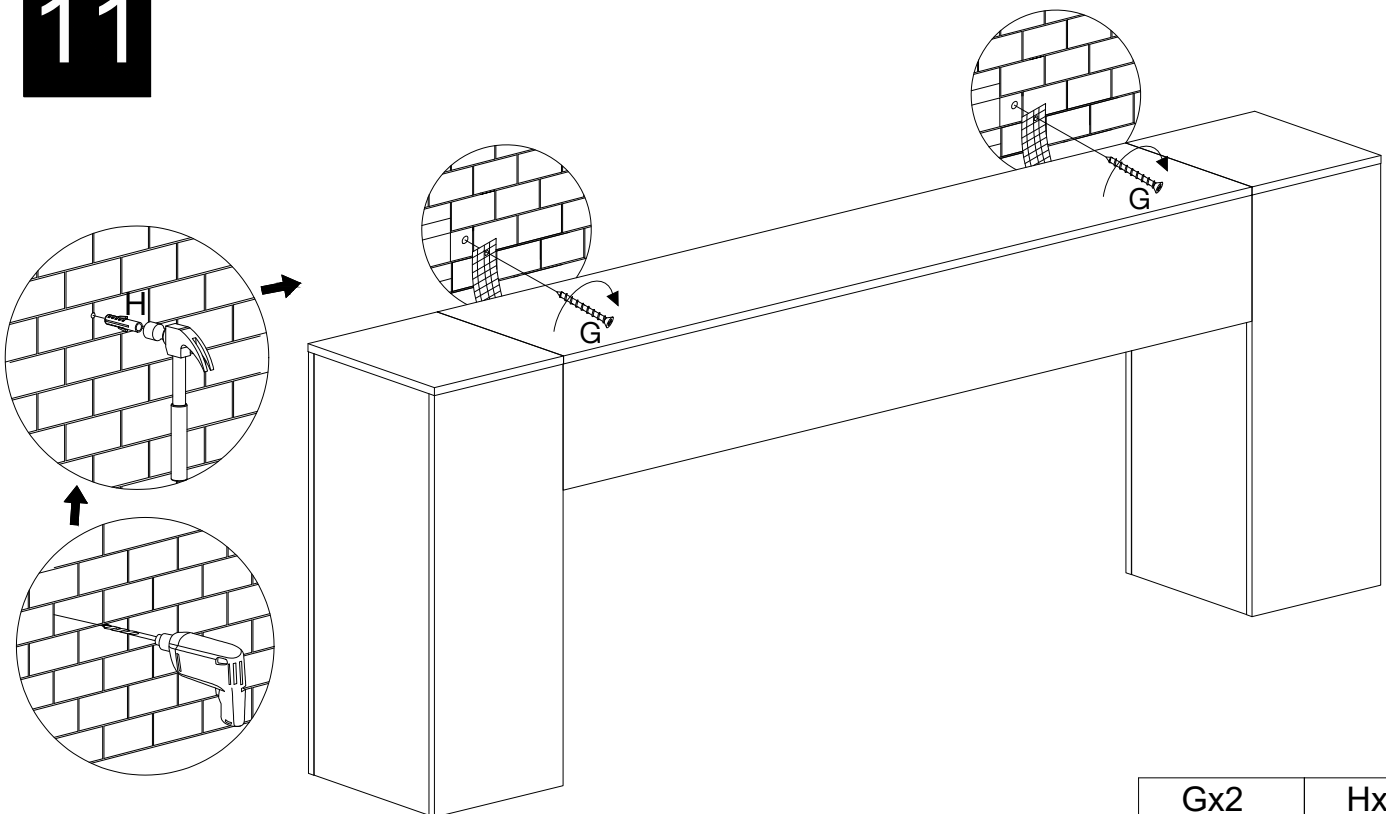

Fx2	Ix2
	
Ø3.5X14mm	155X20mm

11

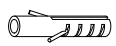

Gx2	Hx2
	
Ø4X35mm	Ø8X40mm