

QUEEN BED

ASSEMBLY INSTRUCTIONS



ASSEMBLY TIPS:

1. Remove hardware from box and sort by size.
2. Please check to see that all hardware and parts are present prior to start of assembly.
3. Please follow attached instructions in the same sequence as numbered to assure fast & easy assembly.

Warning!

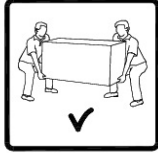

1. Don't attempt to repair or modify parts that are broken or defective. Please contact the store immediately.
2. This product is for home use only and not intended for commercial establishments.



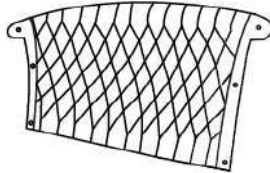
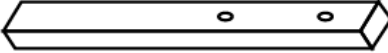

ASSEMBLY TIME	40 MINUTES
----------------------	-------------------

PARTS IDENTIFICATION

B1 (BOX 1)

	PART NAME	FIGURE	QTY
A	HEADBOARD PANEL		1PC
B	HEADBOARD LEG		2PCS
C	HEADBOARD SUPPORT PANEL		1PC

B2 (BOX 2)

D	WING		2PCS
E	WING SUPPORT		2PCS

B3 (BOX 3)

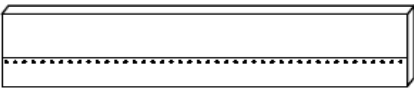
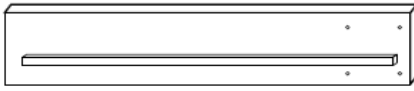
F	FOOTBOARD		1PC
G	BED RAIL		2PCS

ASSEMBLY TIPS:









1. Remove hardware from box and sort by size.
2. Please check to see that all hardware and parts are present prior to start of assembly.
3. Please follow attached instructions in the same sequence as numbered to assure fast & easy assembly.



Warning!

1. Don't attempt to repair or modify parts that are broken or defective. Please contact the store immediately.
2. This product is for home use only and not intended for commercial establishments.

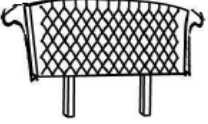
PARTS IDENTIFICATION

	PART NAME	FIGURE	QTY
H	BED SLAT WITHOUT HOLE		10PCS
I	BED SLAT WITH HOLES		3PCS
J	BED SLAT SUPPORT		3PCS
K	FOOTBOARD LEG		2PCS
L	CENTER RAIL		1PC
M	CENTER RAIL SUPPORT		1PC
H	B1 FROM BOX 1 HEADBOARD COMPLETE		1PC
ER	B2 FROM BOX 2 WING COMPLETE		2PCS

ASSEMBLY TIPS:









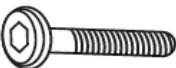

1. Remove hardware from box and sort by size.
2. Please check to see that all hardware and parts are present prior to start of assembly.
3. Please follow attached instructions in the same sequence as numbered to assure fast & easy assembly.

Warning!

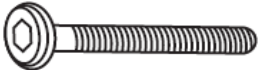
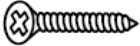
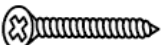
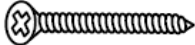
1. Don't attempt to repair or modify parts that are broken or defective. Please contact the store immediately.

HARDWARE IDENTIFICATION

BOX 3 - HARDWARE PACK IS LOCATED

	HARDWARE NAME	FIGURE	QTY
1	ALLEN WRENCH (Φ6 - BLK)		1PC
2	BOLT 1 (Φ6 x 30mm - RBW)		4PCS
3	BOLT 2 (Φ6 x 45mm - RBW)		12PCS
4	BOLT 3 (Φ6 x 60mm - RBW)		5PCS
5	BOLT 4 (Φ6 x 90mm - RBW)		8PCS
6	SHORT FLAT HEAD SCREW (Φ4 x 15mm - RBW)		4PCS
7	MEDIUM FLAT HEAD SCREW (Φ4 x 32mm - RBW)		27PCS
8	LONG FLAT HEAD SCREW (Φ4 x 45mm - RBW)		4PCS
9	BIG FLAT WASHER (Φ3/8 x 25 x 1 - RBW)		24PCS
10	MEDIUM FLAT WASHER (Φ7 x 19 x 2 - RBW)		24PCS
11	SMALL FLAT WASHER (Φ6 x 13 x 1 - RBW)		4PCS
12	LOCK WASHER (Φ6 - RBW)		24PCS
13	LEVELER (M6 x 23mm - RBW)		3PCS

**NOTE : PHILLIPS HEAD SCREW DRIVER IS REQUIRED IN THE ASSEMBLY PROCESS;
HOWEVER, MANUFACTURER DOES NOT PROVIDE THIS ITEM.**

B1 - BOX 1

STEP 1

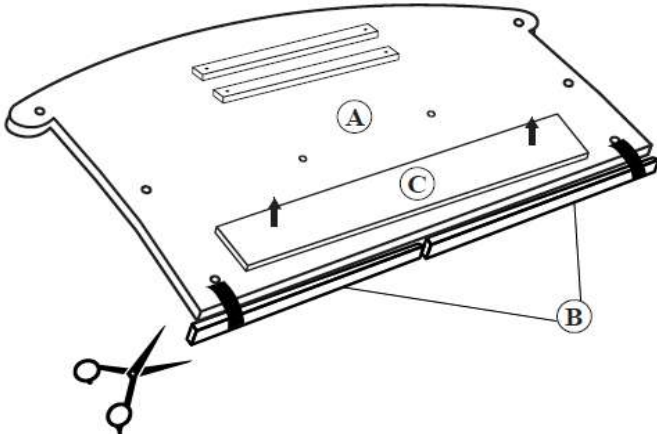

STEP 2

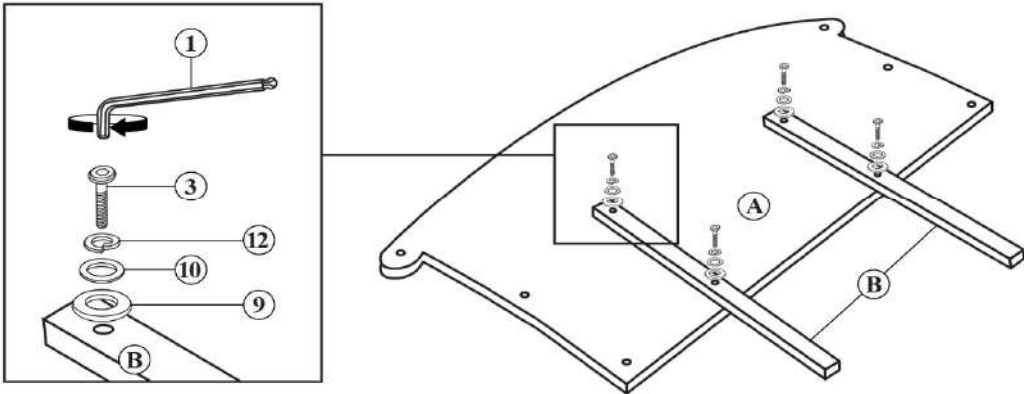

STEP 3

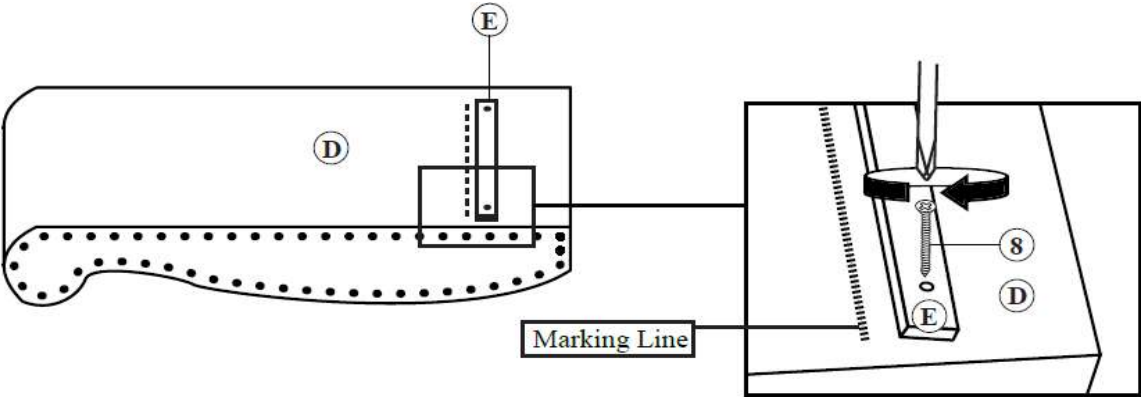

*Assemble wing support at the bottom of the marking line.

B1 & B2 - BOX 1 & BOX 2

STEP 4

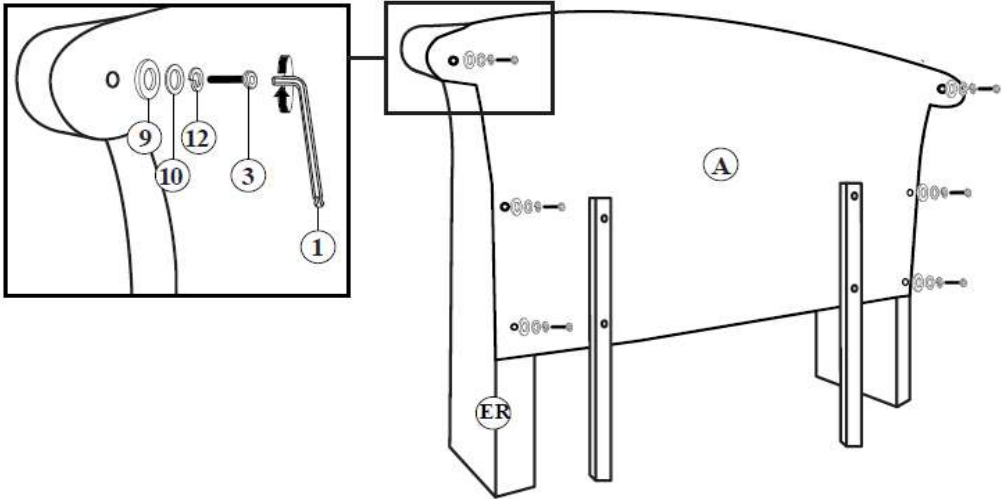

B3 - BOX 3

STEP 5

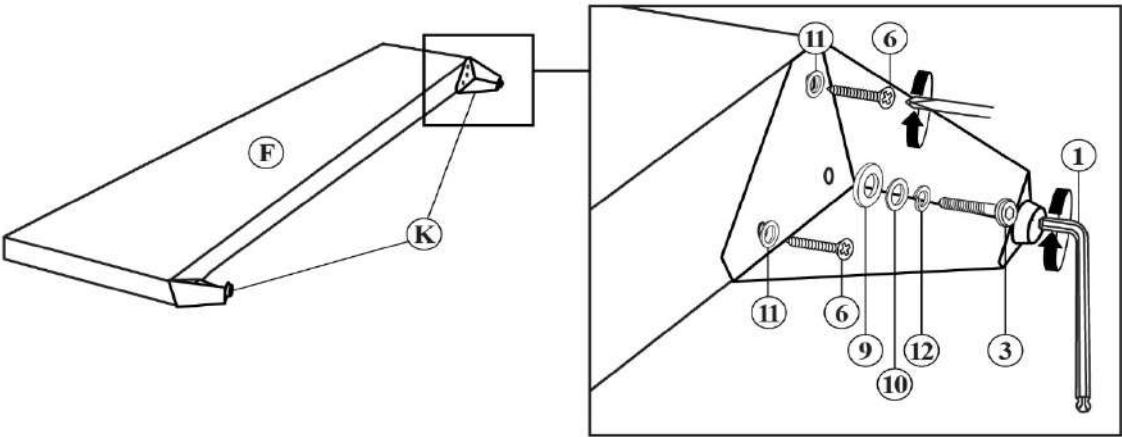

B1 - B3 - BOX 1 TO BOX 3

STEP 6

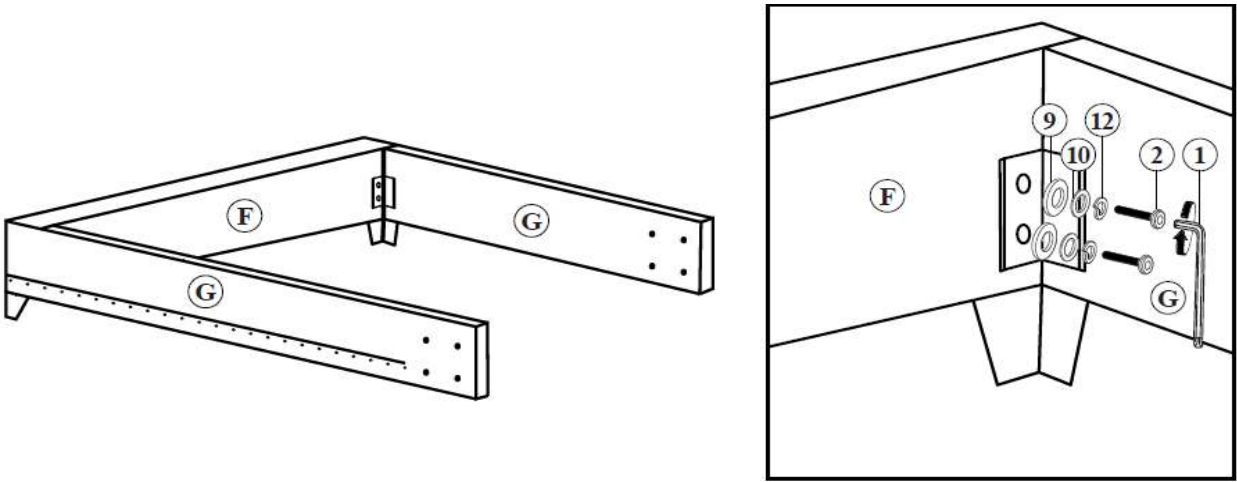

STEP 7

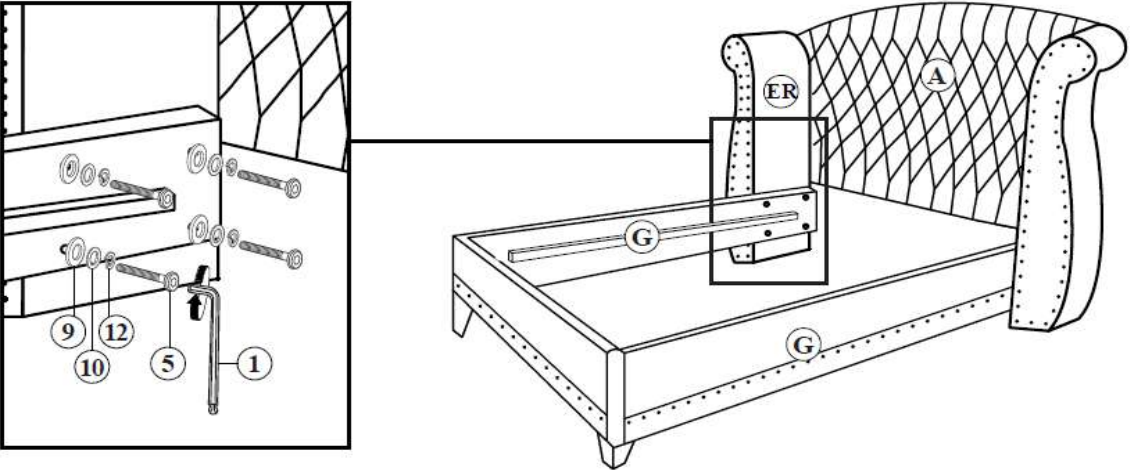

STEP 8

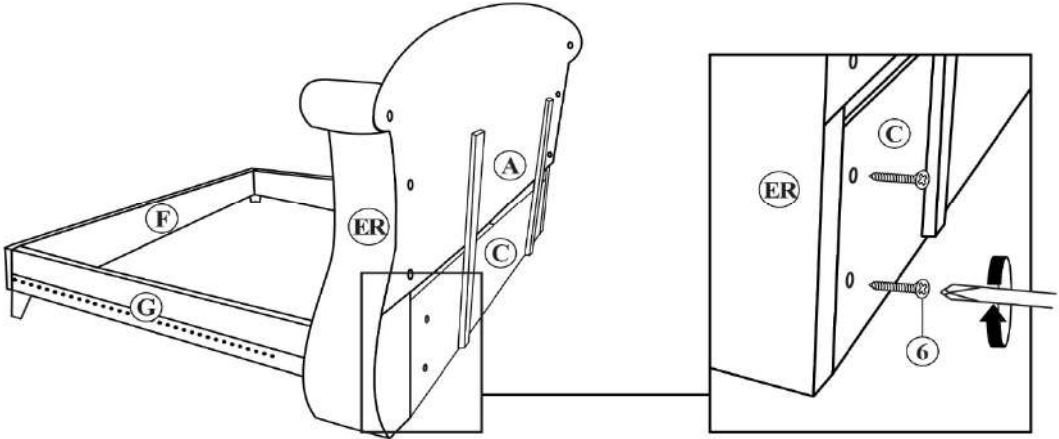

STEP 9

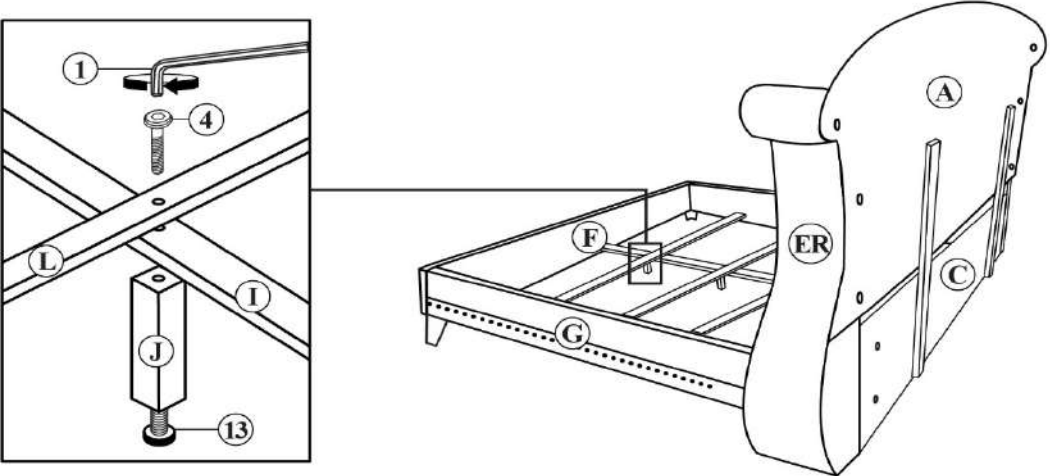

STEP 10

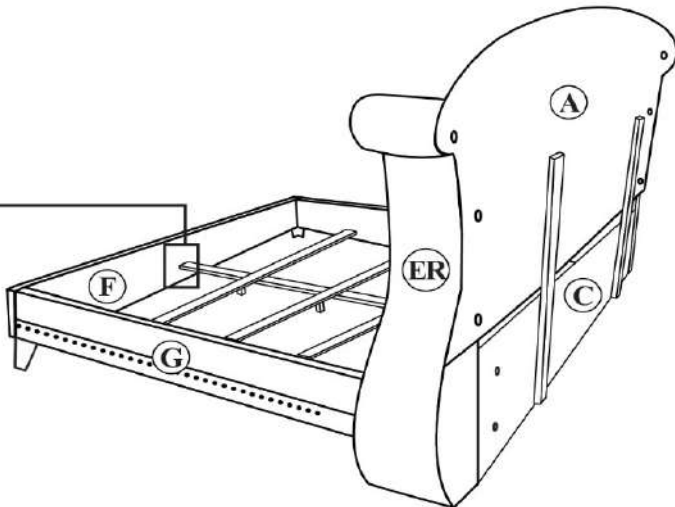
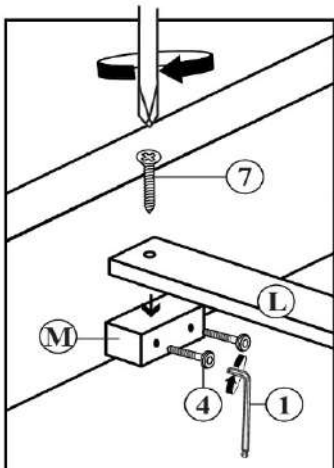

STEP 11
COMPLETE

