

"IMPORTANT, RETAIN FOR FUTURE REFERENCE: READ CAREFULLY"

German: WICHTIG, FÜR SPÄTERE NACHSCHLAGE AUFBEWAHREN: SORGFÄLTIG LESEN





Spanish: IMPORTANTE, GUARDAR PARA REFERENCIA FUTURA: LEER ATENTAMENTE

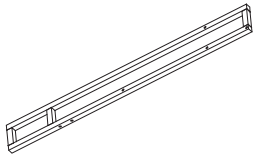
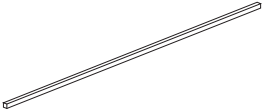
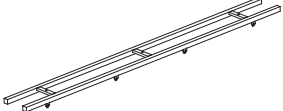
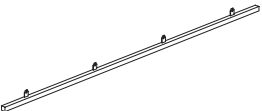
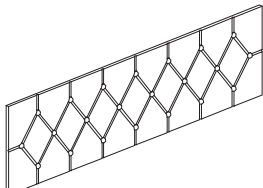
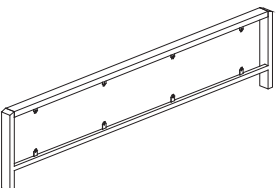

Italian: IMPORTANTE, CONSERVARE PER RIFERIMENTI FUTURI: LEGGERE ATTENTAMENTE

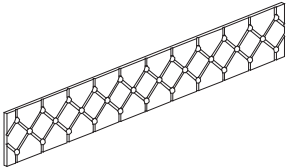
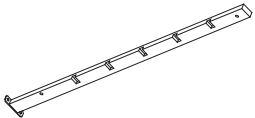
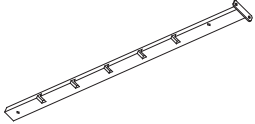
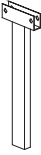
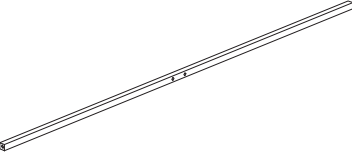
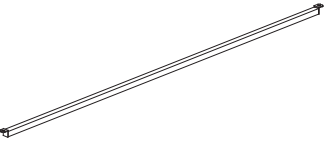
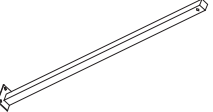
French: IMPORTANT, À CONSERVER POUR RÉFÉRENCE FUTURE : LIRE ATTENTIVEMENT

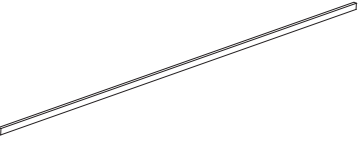
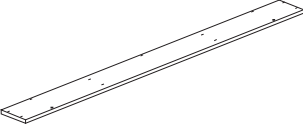
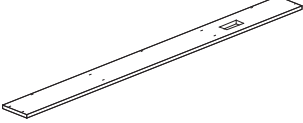
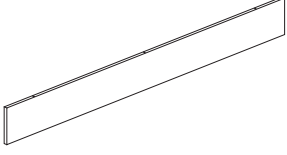
- !**
- Two or more people are required for assembly.
 - To avoid squeaking, please tighten the bolts all the way.
An electric drill is recommended for the assembly.
 - Professional installation is highly recommended.
1. Für den Zusammenbau werden zwei oder mehr Personen benötigt.
2. Um Quietschgeräusche zu vermeiden, ziehen Sie die Schrauben bitte ganz fest.
Die Verwendung einer elektrischen Bohrmaschine wird empfohlen.
3. Ein fachgerechter Einbau wird dringend empfohlen.
1. Il faut au moins deux personnes pour le montage.
2. Pour éviter tout grincement, veuillez serrer les boulons à fond. Il est recommandé d'utiliser une perceuse électrique.
3. Une installation professionnelle est fortement recommandée.
1. E' necessario due o più persone per l'installazione.
2. Per evitare cigolii, serrare bene i bulloni. Si consiglia di utilizzare un trapano elettrico.
3. Si consiglia vivamente un'installazione professionale.
1. Se necesitan dos o más personas para el montaje.
2. Para evitar chirridos, apriete todos los tornillos. Se recomienda utilizar un taladro eléctrico.
3. Se recomienda encarecidamente la instalación profesional.

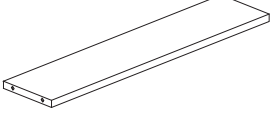
| Item no. Nr. N° d'article Articolo No. Artículo No. | Reference Image Referenzbild Image de référence Immagine di riferimento Imagen de referencia | Qty. Menge Qté. Qtà Cant. | Item no. Nr. N° d'article Articolo No. Artículo No. | Reference Image Referenzbild Image de référence Immagine di riferimento Imagen de referencia | Qty. Menge Qté. Qtà Cant. |
|-----------------------------------------------------------------|----------------------------------------------------------------------------------------------------------|---------------------------------------|-----------------------------------------------------------------|----------------------------------------------------------------------------------------------------------|---------------------------------------|
| 1 |  | X2 | 2 |  | X1 |
| 3 |  | X1 | 4 |  | X1 |
| 5 |  | X1 | 6 |  | X1 |

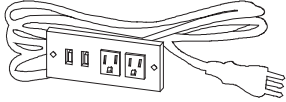
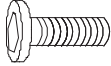
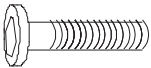
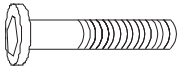
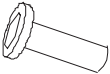
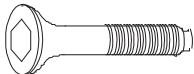
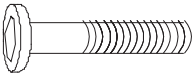
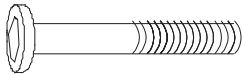
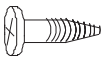
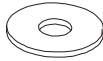
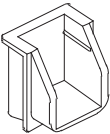
| Item no. Nr. N° d'article Articolo No. Artículo No. | Reference Image Referenzbild Image de référence Immagine di riferimento Imagen de referencia | Qty. Menge Qté. Qtà Cant. | Item no. Nr. N° d'article Articolo No. Artículo No. | Reference Image Referenzbild Image de référence Immagine di riferimento Imagen de referencia | Qty. Menge Qté. Qtà Cant. |
|-----------------------------------------------------------------|----------------------------------------------------------------------------------------------------------|---------------------------------------|-----------------------------------------------------------------|----------------------------------------------------------------------------------------------------------|---------------------------------------|
| 7 |  | X1 | 8 |  | X2 |
| 9 |  | X2 | 10 |  | X2 |
| 11 |  | X2 | 12 |  | X1 |
| 13 |  | X2 | 14 |  | X2 |
| 15 |  | X1 | 16 |  | X10 |
| 17 |  | X1 | 18 |  | X1 |
| 19 |  | X1 | 20 |  | X2 |
| 21 |  | X2 | 22 |  | X1 |

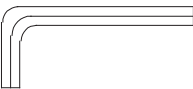
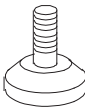
| Item no. Nr. N° d'article Articolo No. Artículo No. | Reference Image Referenzbild Image de référence Immagine di riferimento Imagen de referencia | Qty. Menge Qté. Qtà Cant. | Item no. Nr. N° d'article Articolo No. Artículo No. | Reference Image Referenzbild Image de référence Immagine di riferimento Imagen de referencia | Qty. Menge Qté. Qtà Cant. |
|-----------------------------------------------------------------|----------------------------------------------------------------------------------------------------------|---------------------------------------|-----------------------------------------------------------------|----------------------------------------------------------------------------------------------------------|---------------------------------------|
| 23 |  | X1 | A |  M6X16mm | X32 |
| B |  M6X25mm | X7 | C |  M6X45mm | X12 |
| D |  M6X18mm | X6 | F |  M7X40mm | X26 |
| G |  M8X35mm | X2 | H |  M8X55mm | X3 |
| J |  M3x15mm | X2 | K |  | X38 |
| L |  | X20 | M |  M4 | X2 |
| N |  M5 | X1 | O |  | X5 |

1

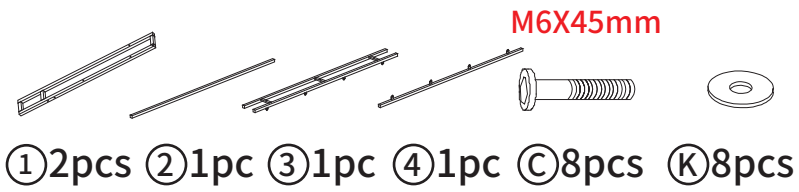

Note: Make sure the positions marked by triangles are facing the same direction.

Hinweis: Stellen Sie sicher, dass die Positionen, die durch Dreiecke markiert sind, in die gleiche Richtung zeigen.

Note : Assurez-vous que les positions marquées par des triangles sont orientées dans la même direction.

Nota: Assicurati che le posizioni contrassegnate da triangoli siano rivolte nella stessa direzione.

Nota: Asegúrate de que las posiciones marcadas con triángulos estén orientadas en la misma dirección.

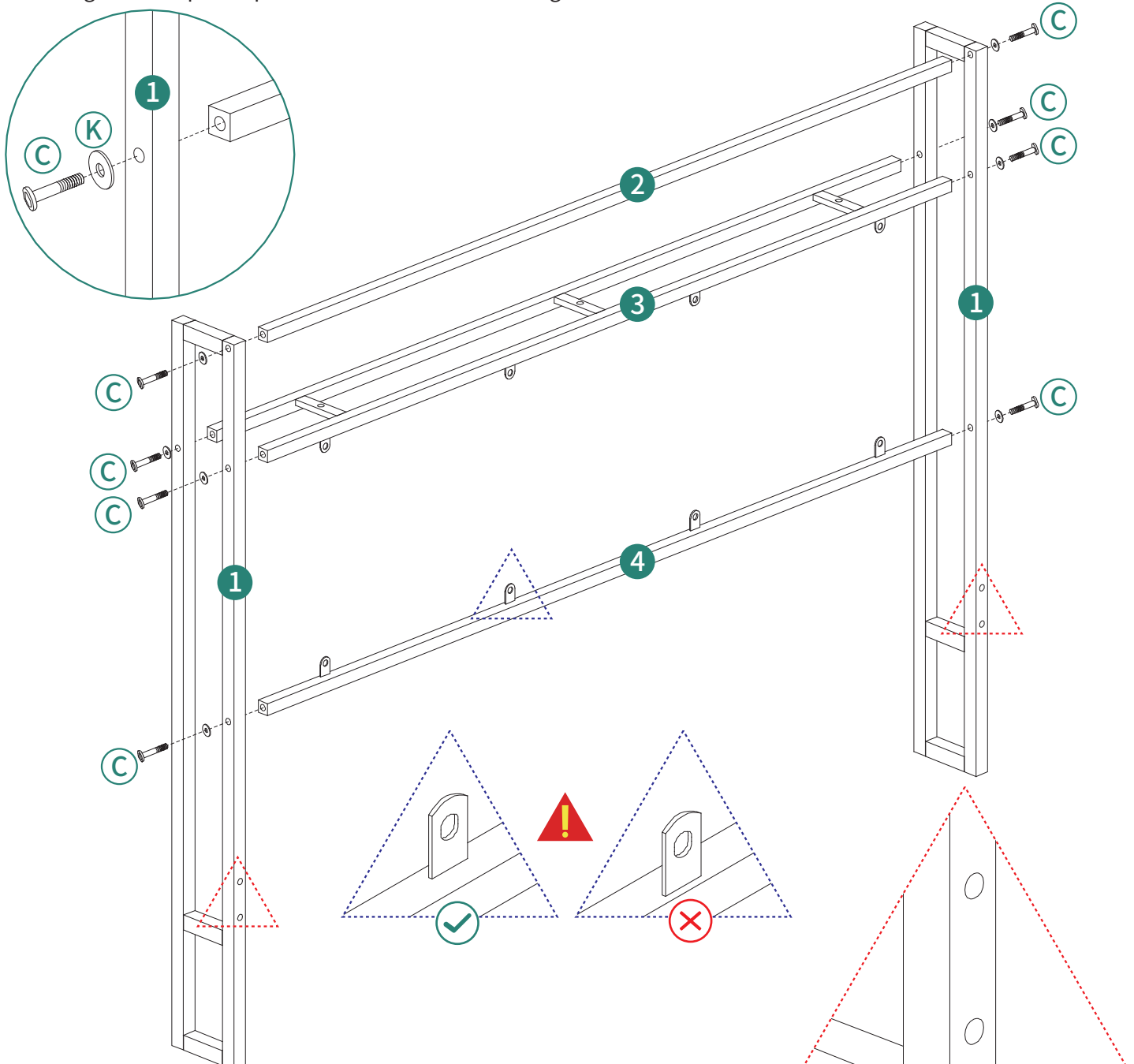

2

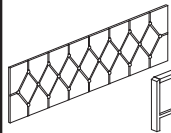

⑤ 1pc

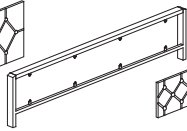

⑥ 1pc

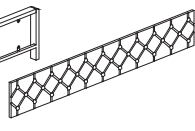

⑦ 1pc

M6X16mm



Ⓐ 16pcs



Ⓚ 16pcs

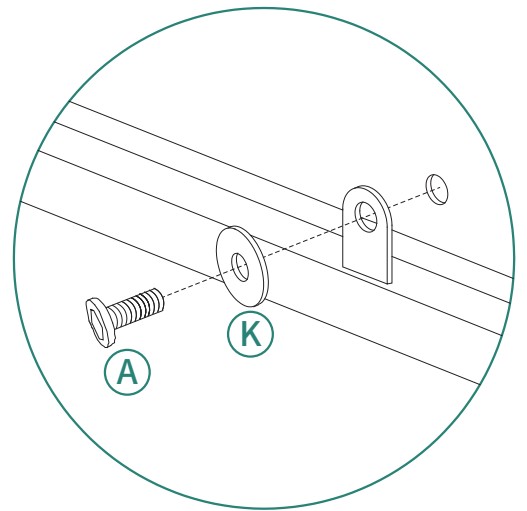
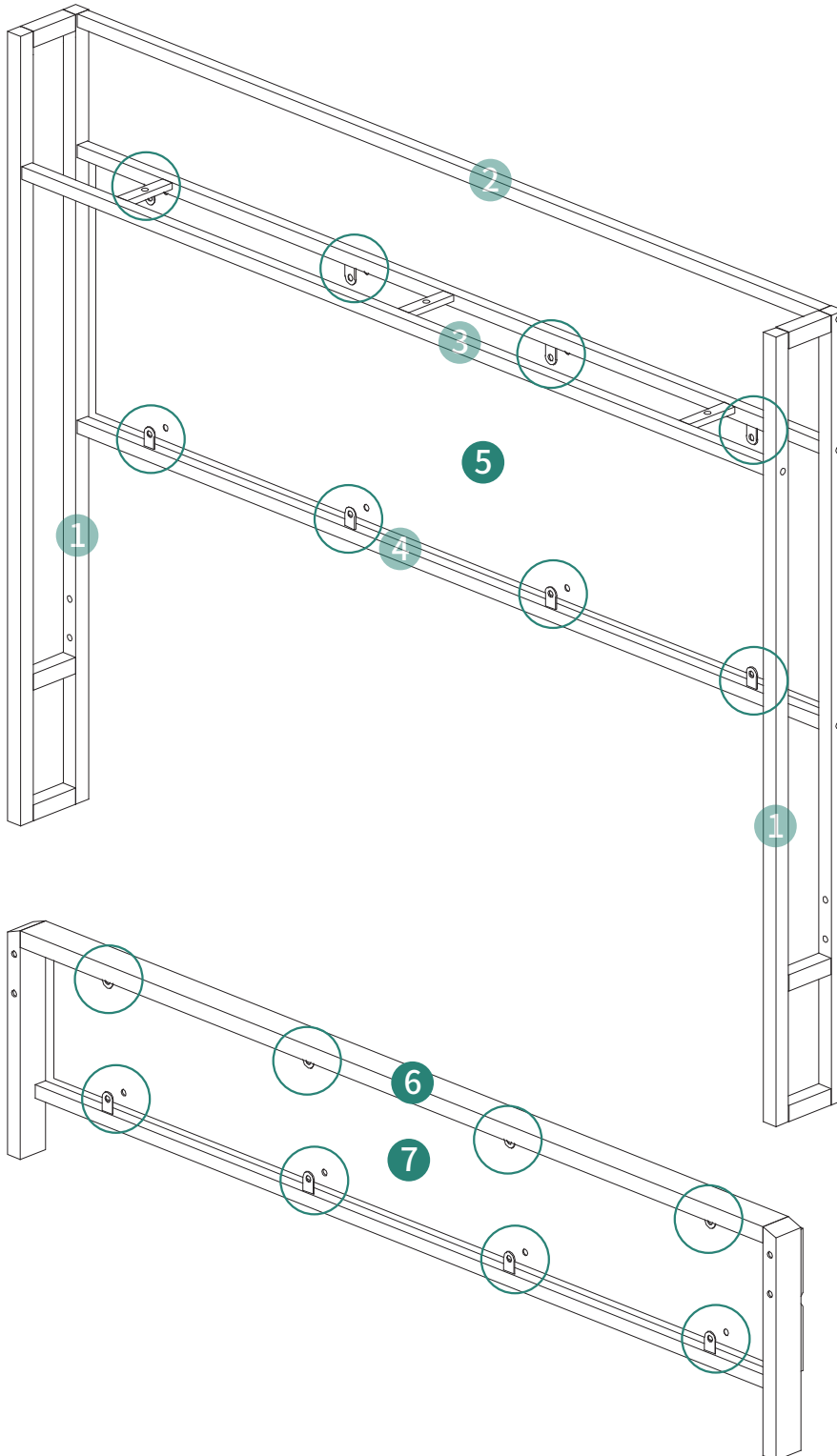

3

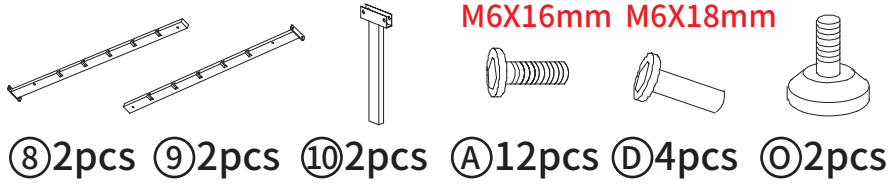
- M6X16mm M6X18mm
- 
- ⑧ 2pcs
 - ⑨ 2pcs
 - ⑩ 2pcs
 - Ⓐ 12pcs
 - Ⓓ 4pcs
 - ⓪ 2pcs

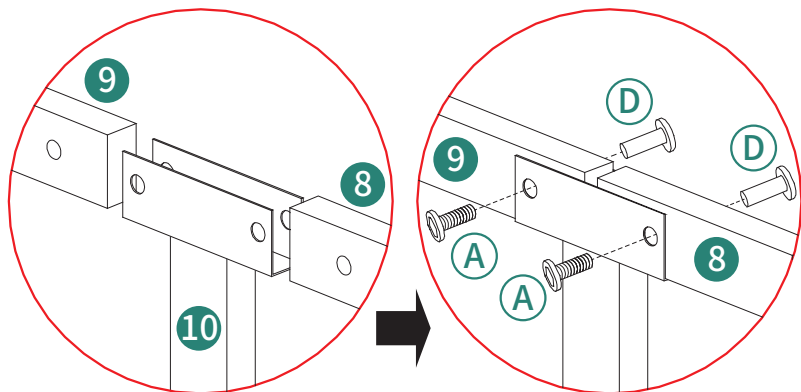
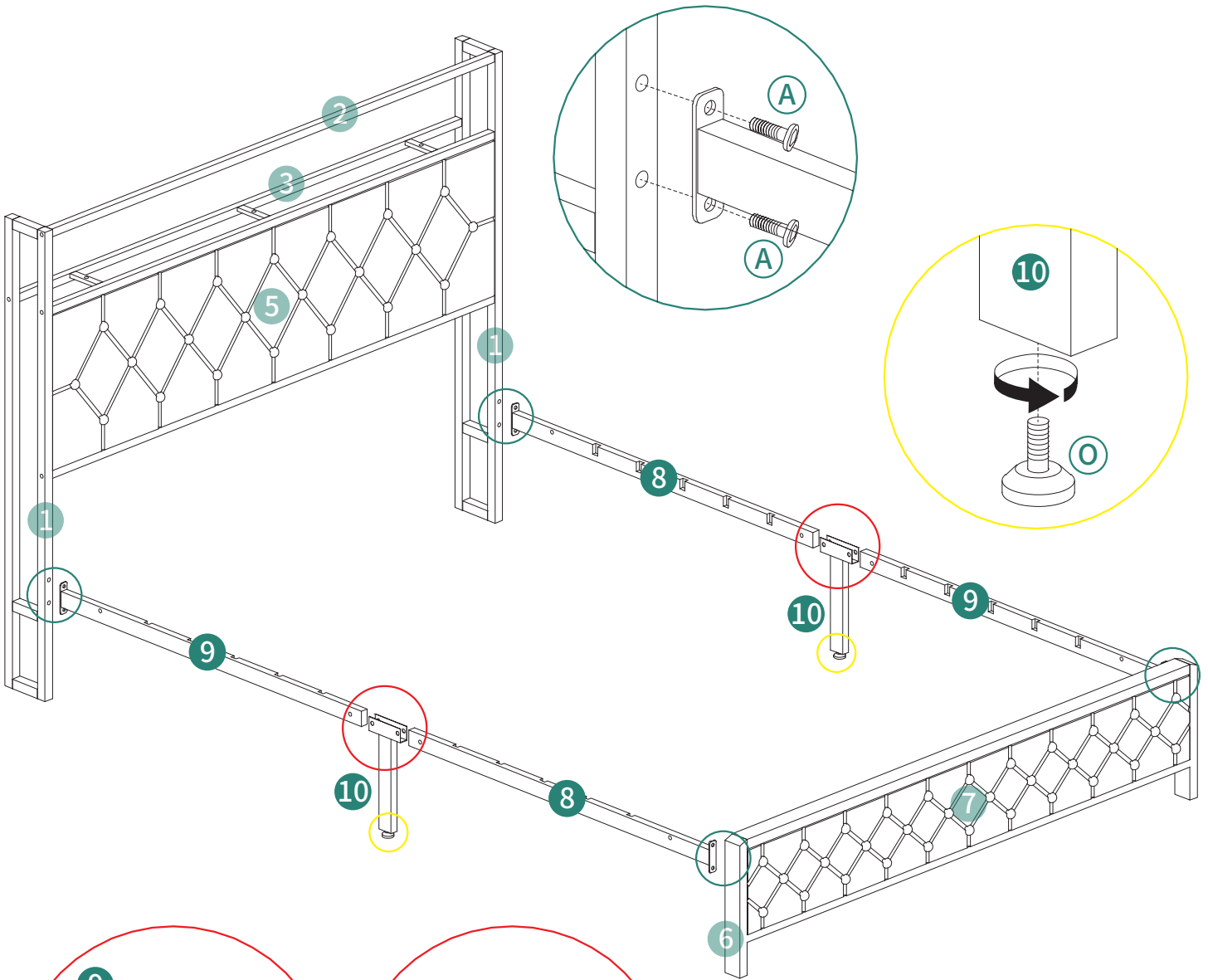

4

M6X45mm M8X55mm

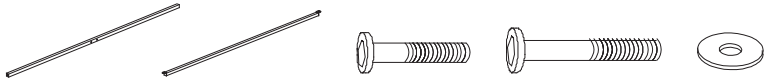

⑪ 2pcs ⑫ 1pc ③ 4pcs ④ 2pcs ⑤ 6pcs

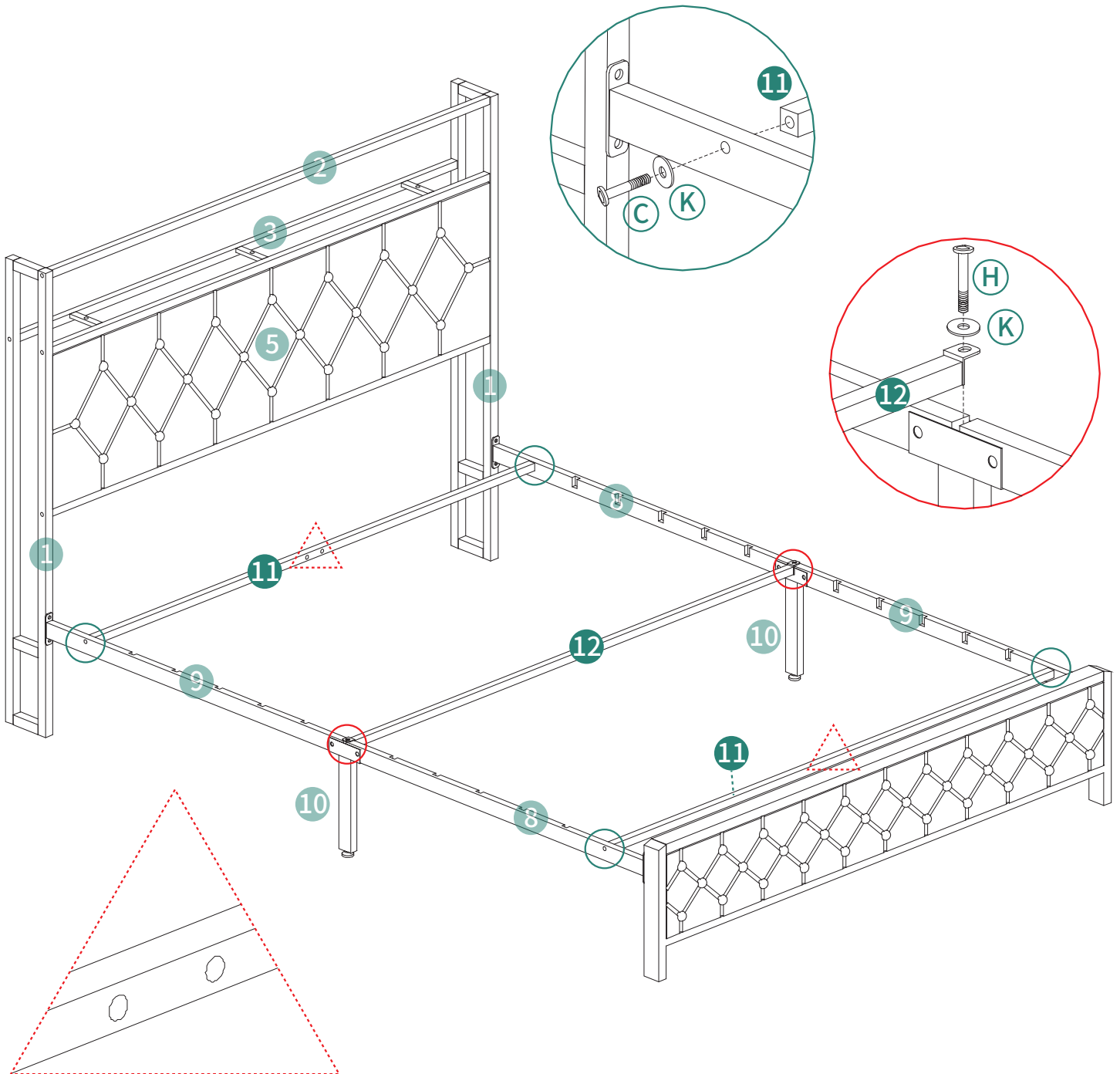

5

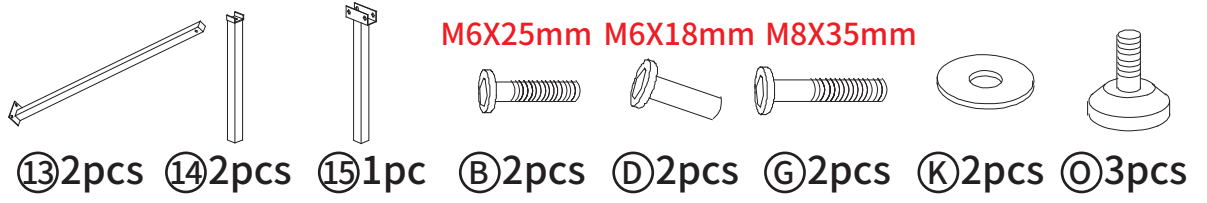
- M6X25mm M6X18mm M8X35mm
- 
- ⑬ 2pcs
 - ⑭ 2pcs
 - ⑮ 1pc
 - Ⓑ 2pcs
 - Ⓓ 2pcs
 - Ⓖ 2pcs
 - Ⓚ 2pcs
 - Ⓞ 3pcs

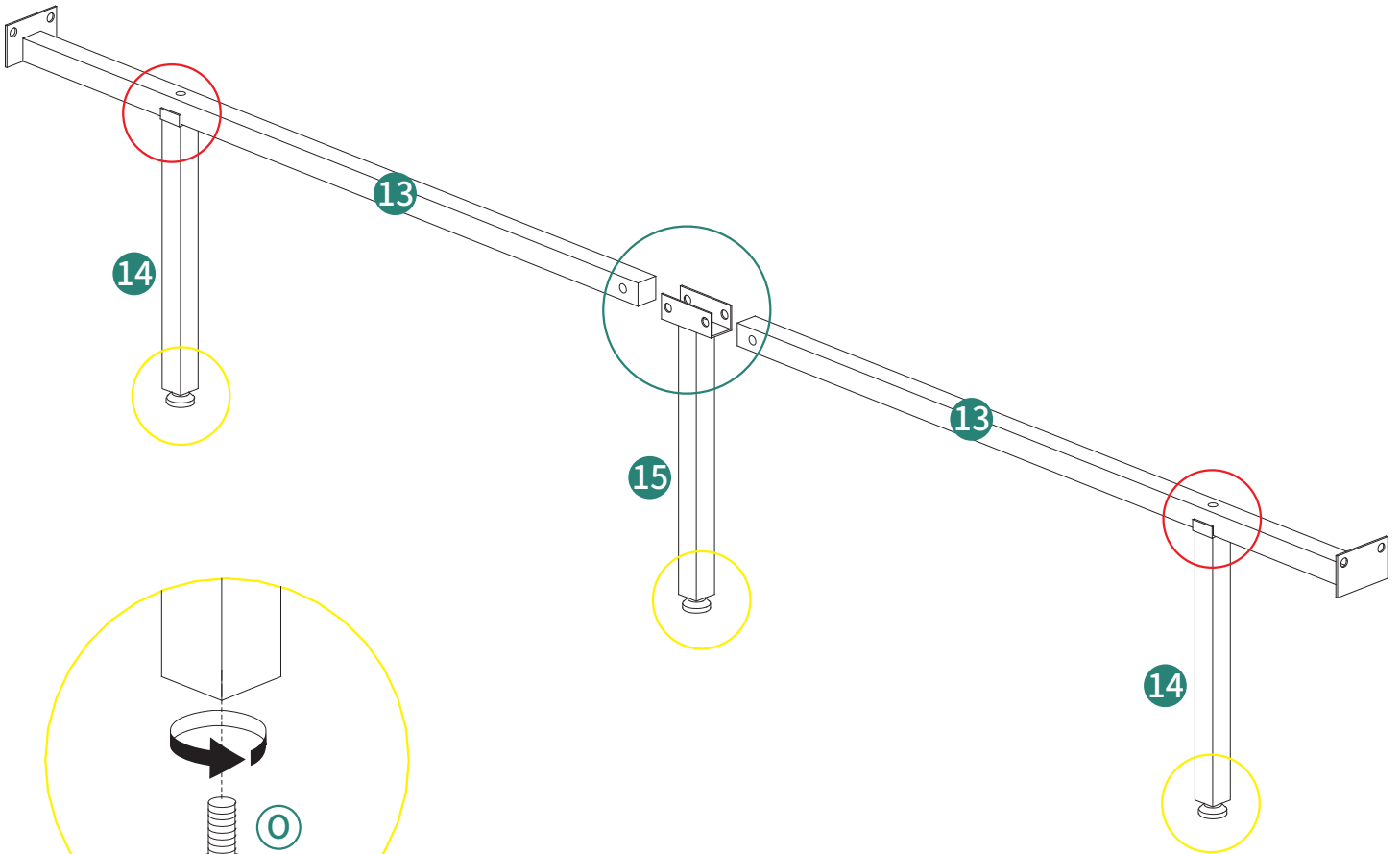
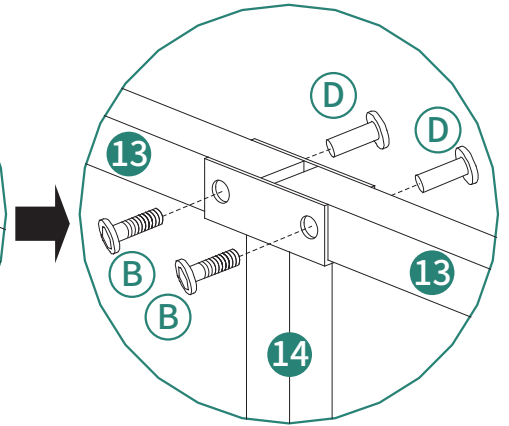
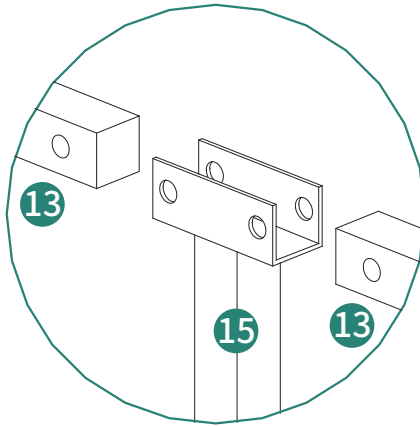
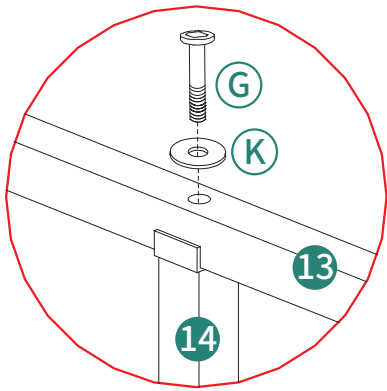

6

M6X16mm M8X55mm

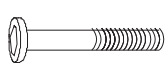

(A) 4pcs

(H) 1pc

(K) 1pc

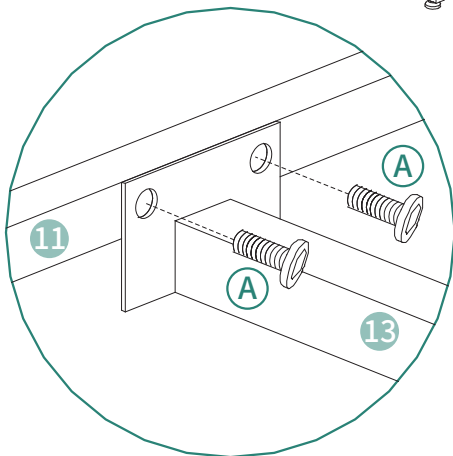
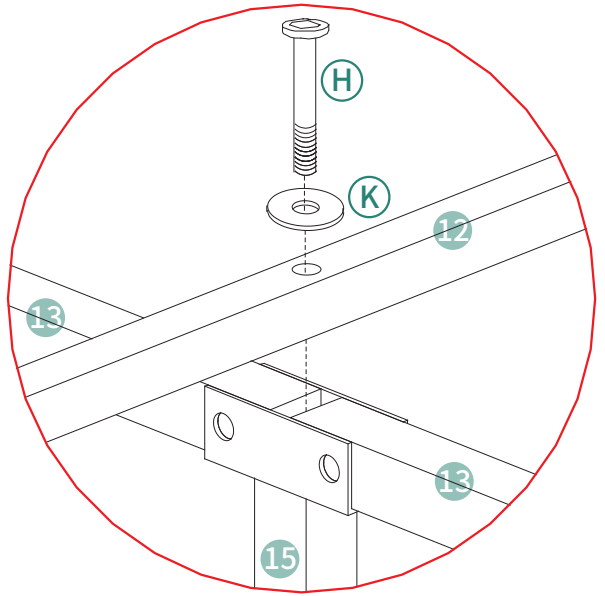
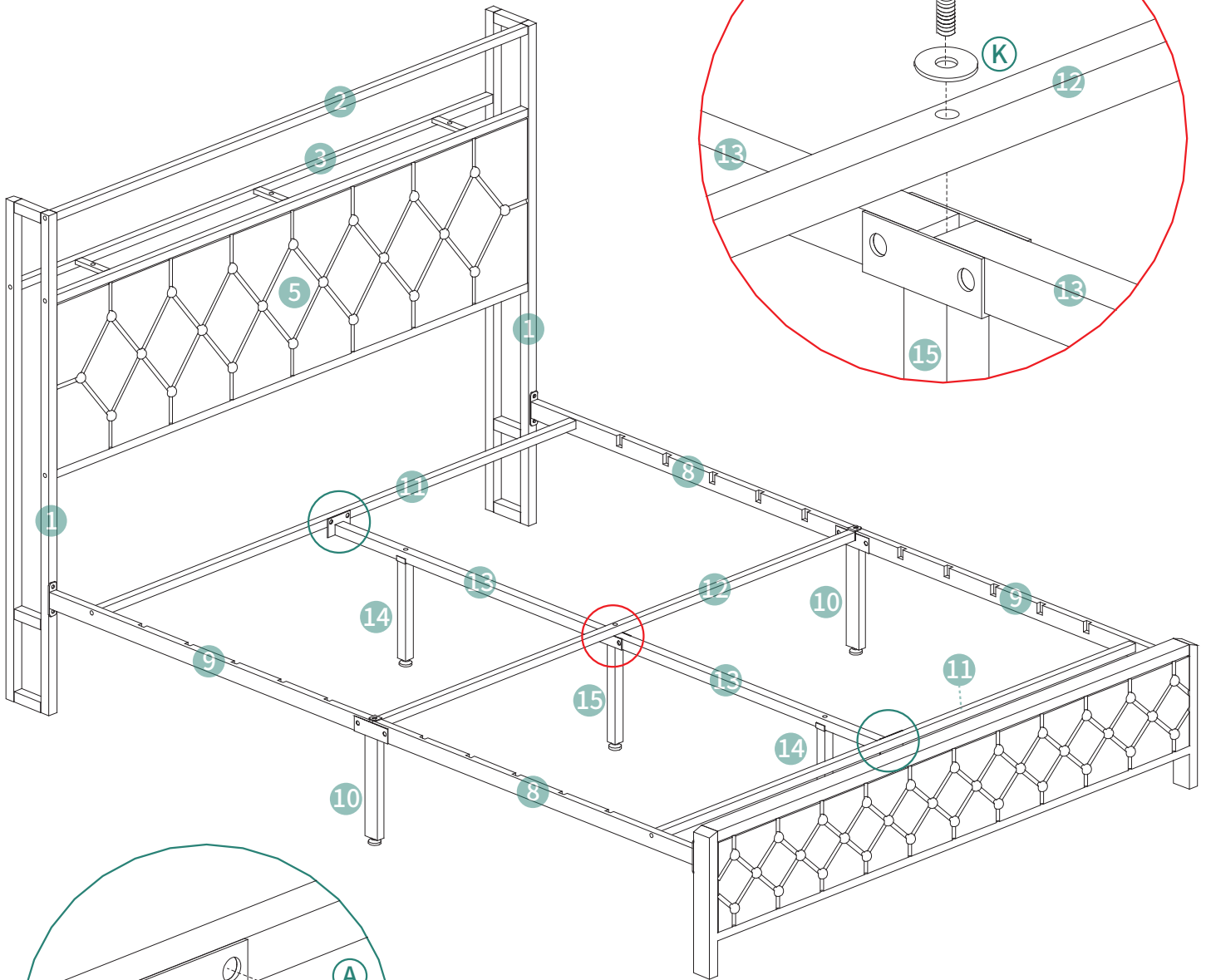

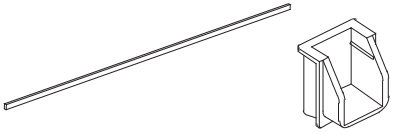

7

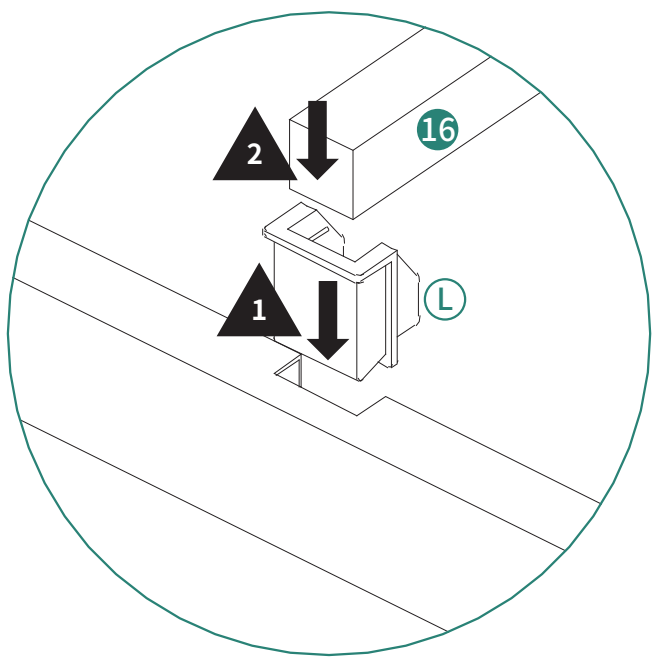
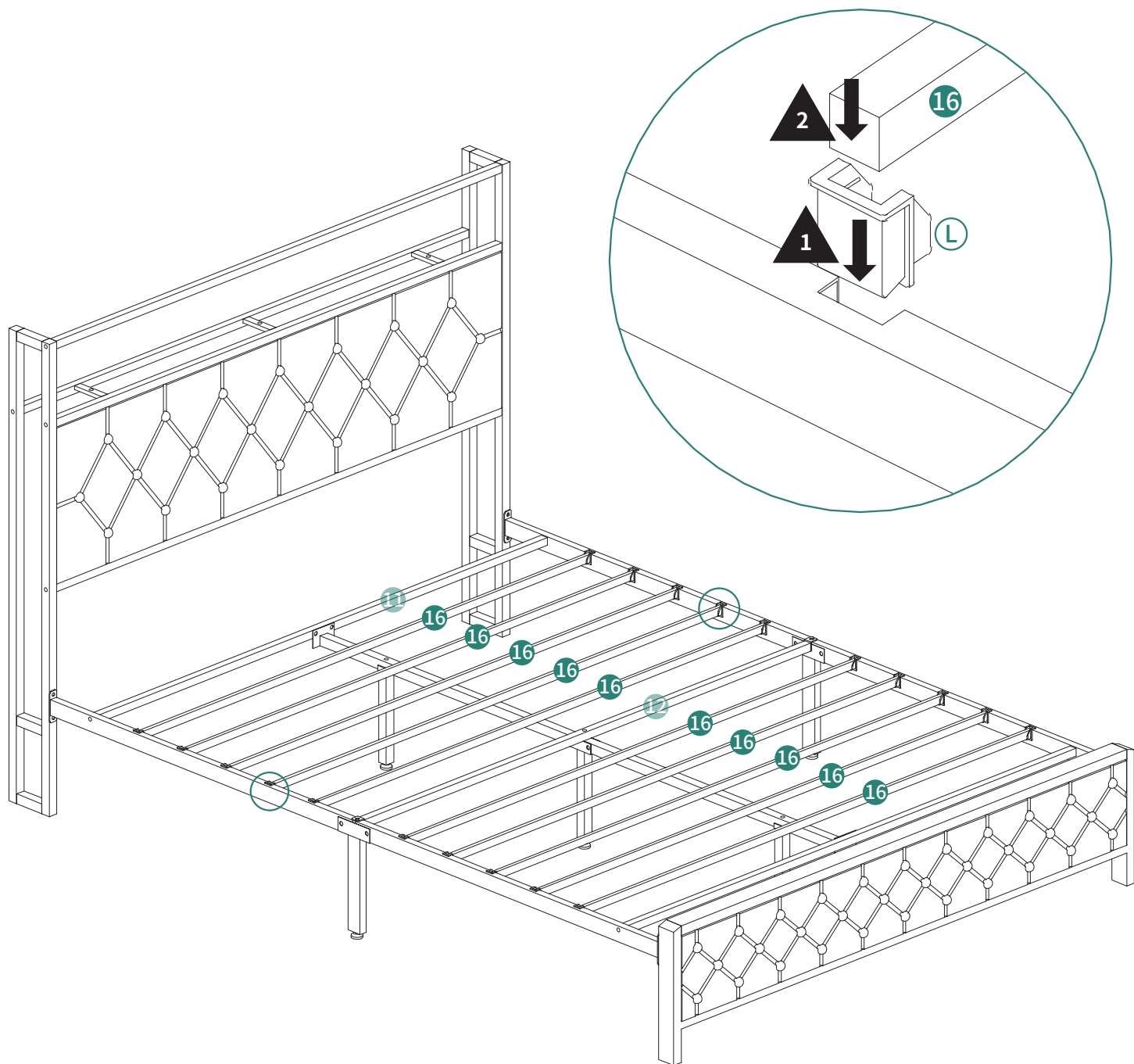

①6 10pcs ①L 20pcs

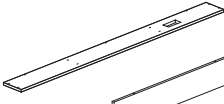

8

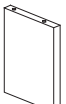
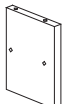
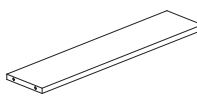
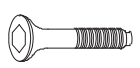
-  18 1pc
 -  19 1pc
 -  20 2pcs
 -  21 2pcs
 -  22 1pc
 -  F 15pcs
- M7X40mm

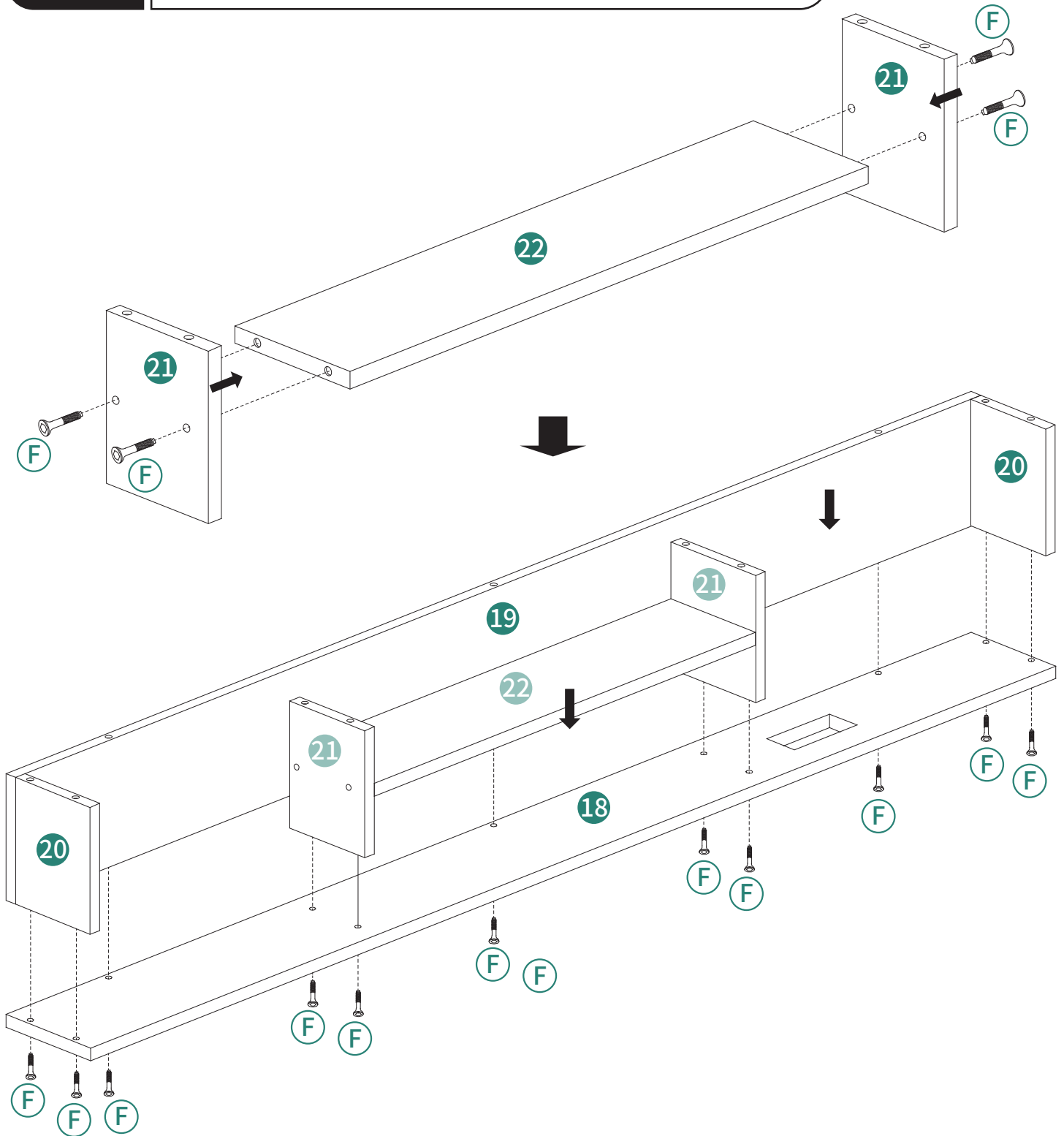

9

M7X40mm
⑰1pc ⑱11pcs

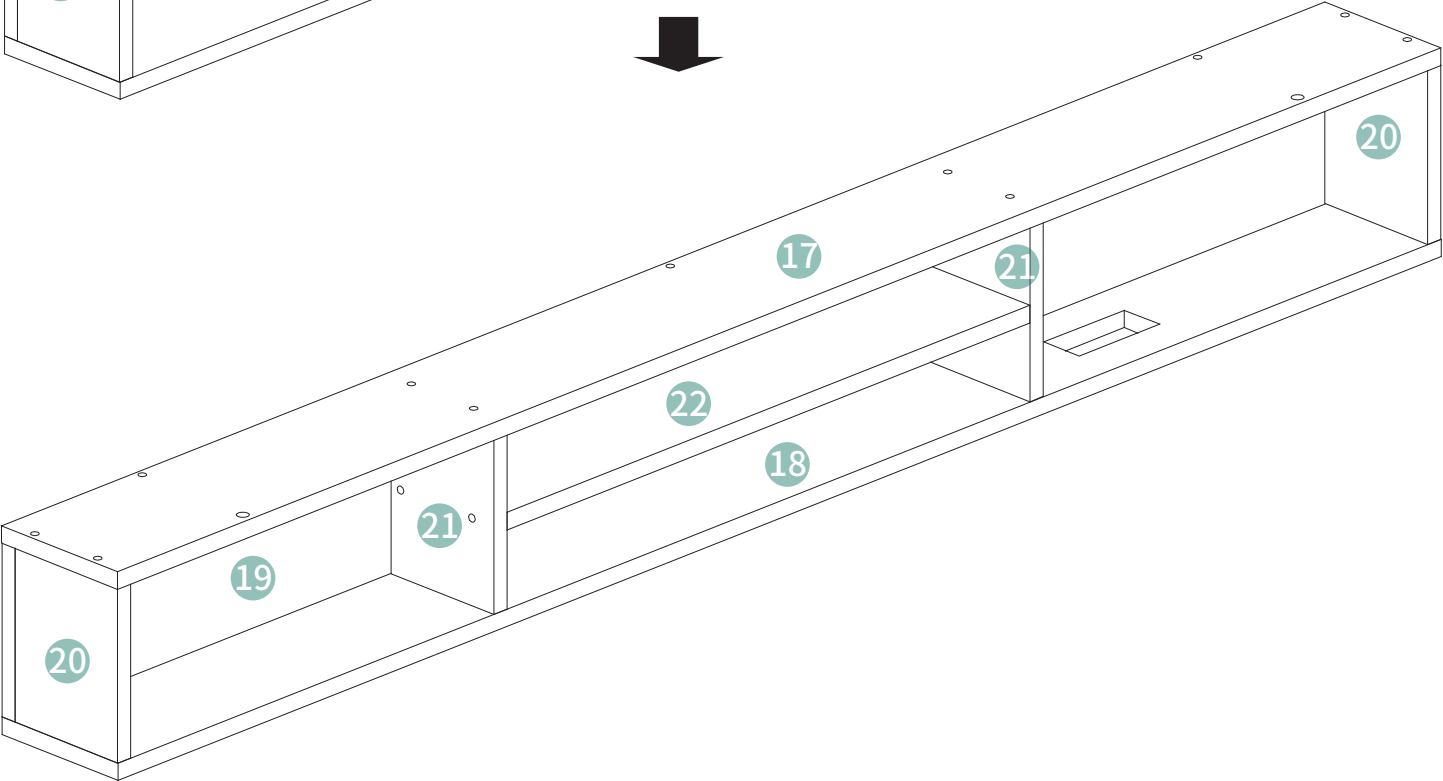
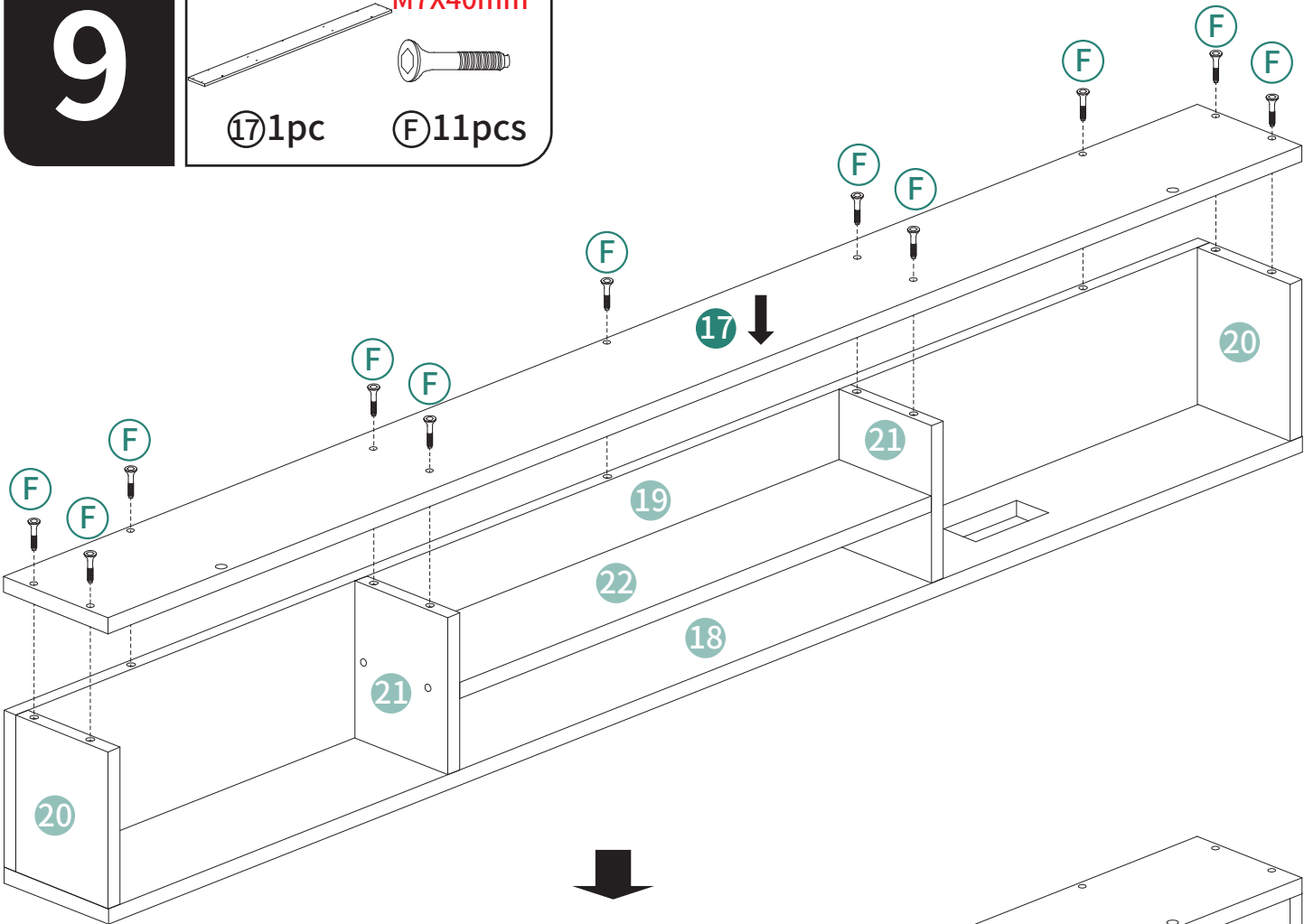

10

M3x15mm

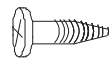
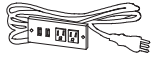

23 1pc

J 2pcs

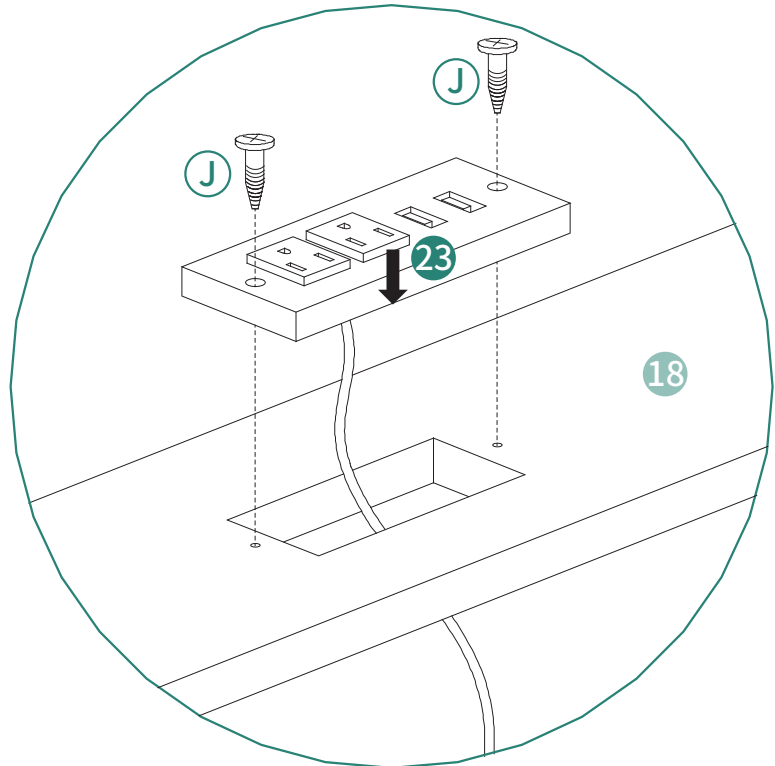
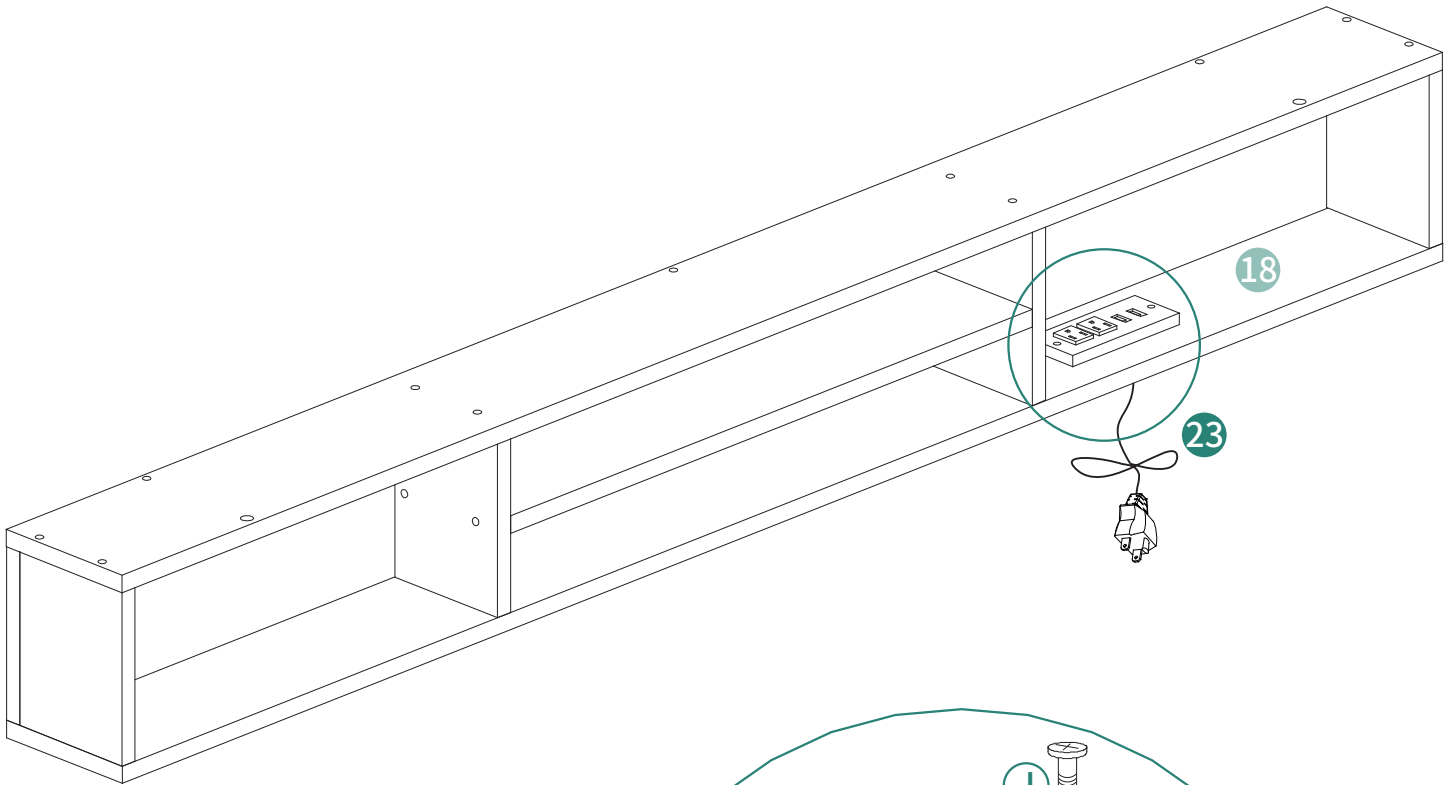

11

M6X25mm

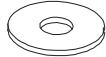
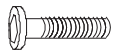

Ⓑ5pcs Ⓚ5pcs

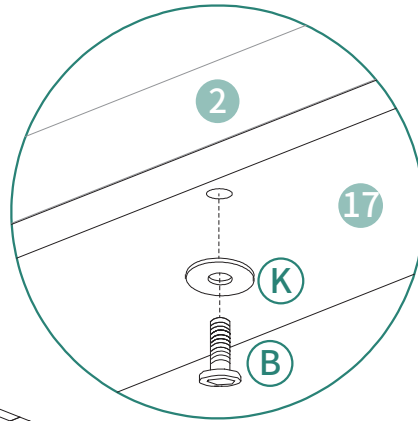

Bottom View
Unteransicht
Vue du bas
Vista dal basso
Vista inferior

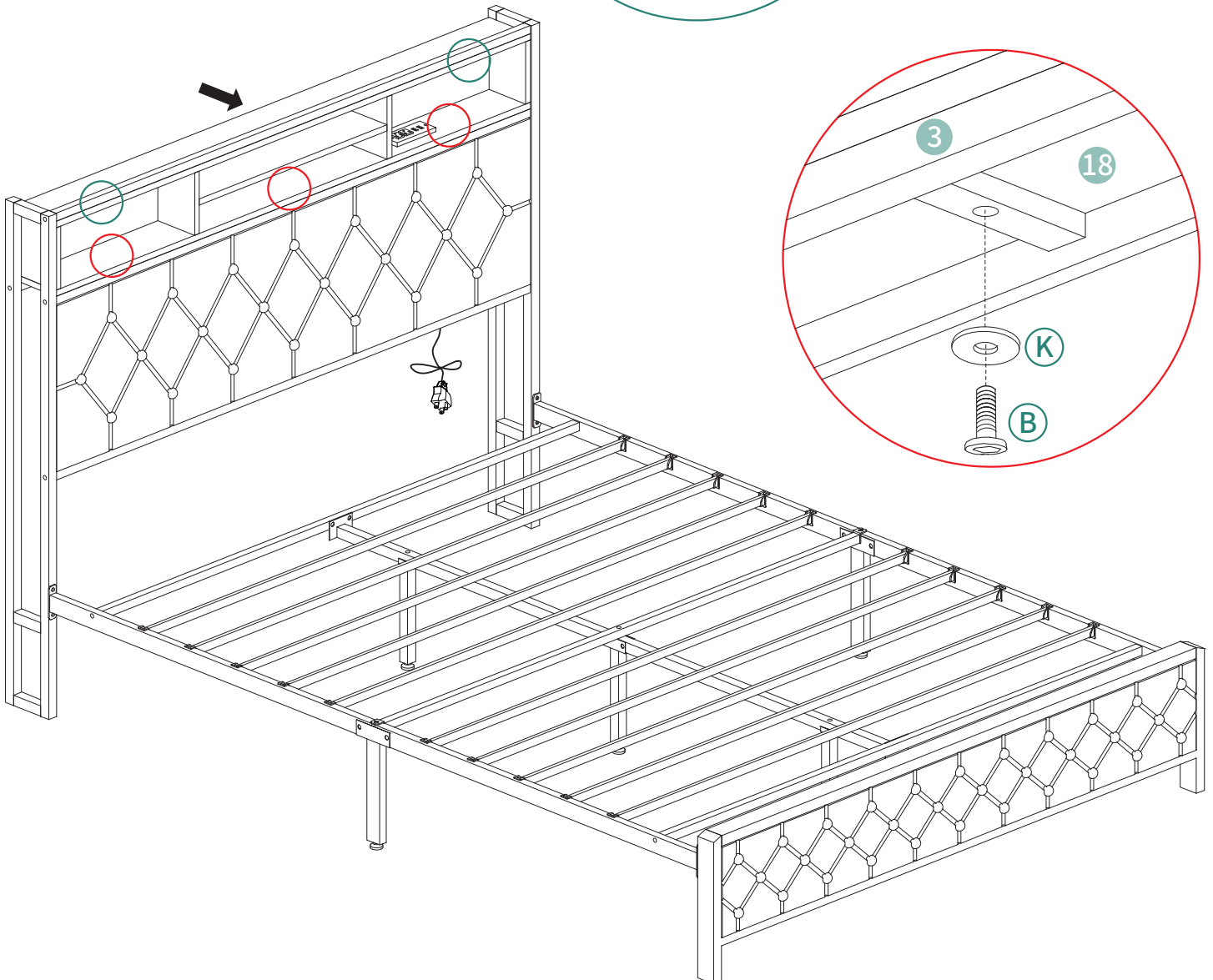

12

Not included
Nicht enthalten
Non inclus
Non incluso
No incluido

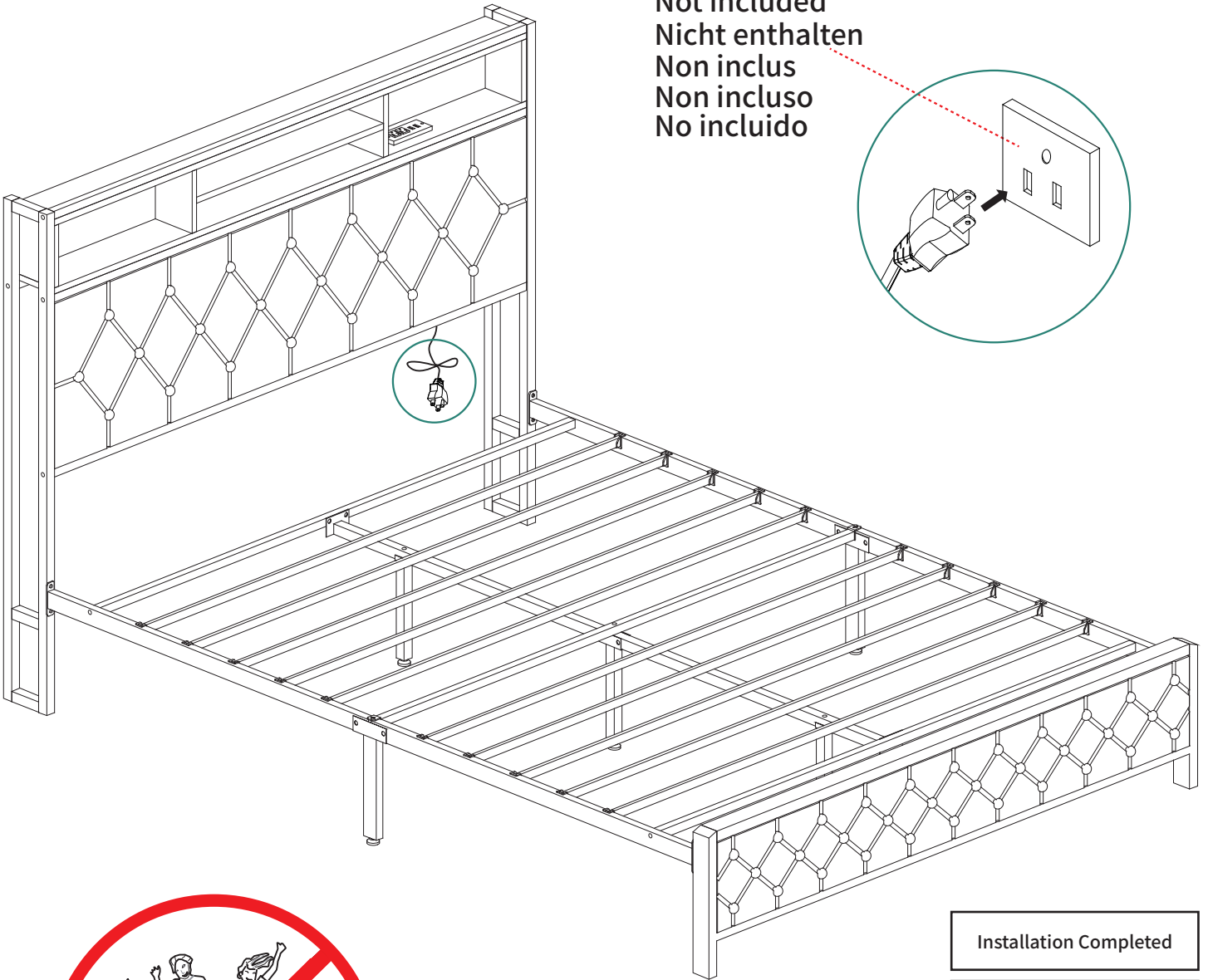
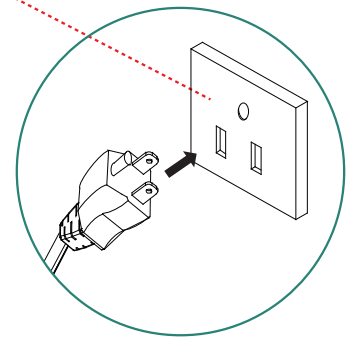

- Installation Completed
- Installation abgeschlossen
- Installation complétée
- Installazione completata
- Instalación completada