

SICOTAS

ND115A2XLTY1223

ND115A2XLTY1224

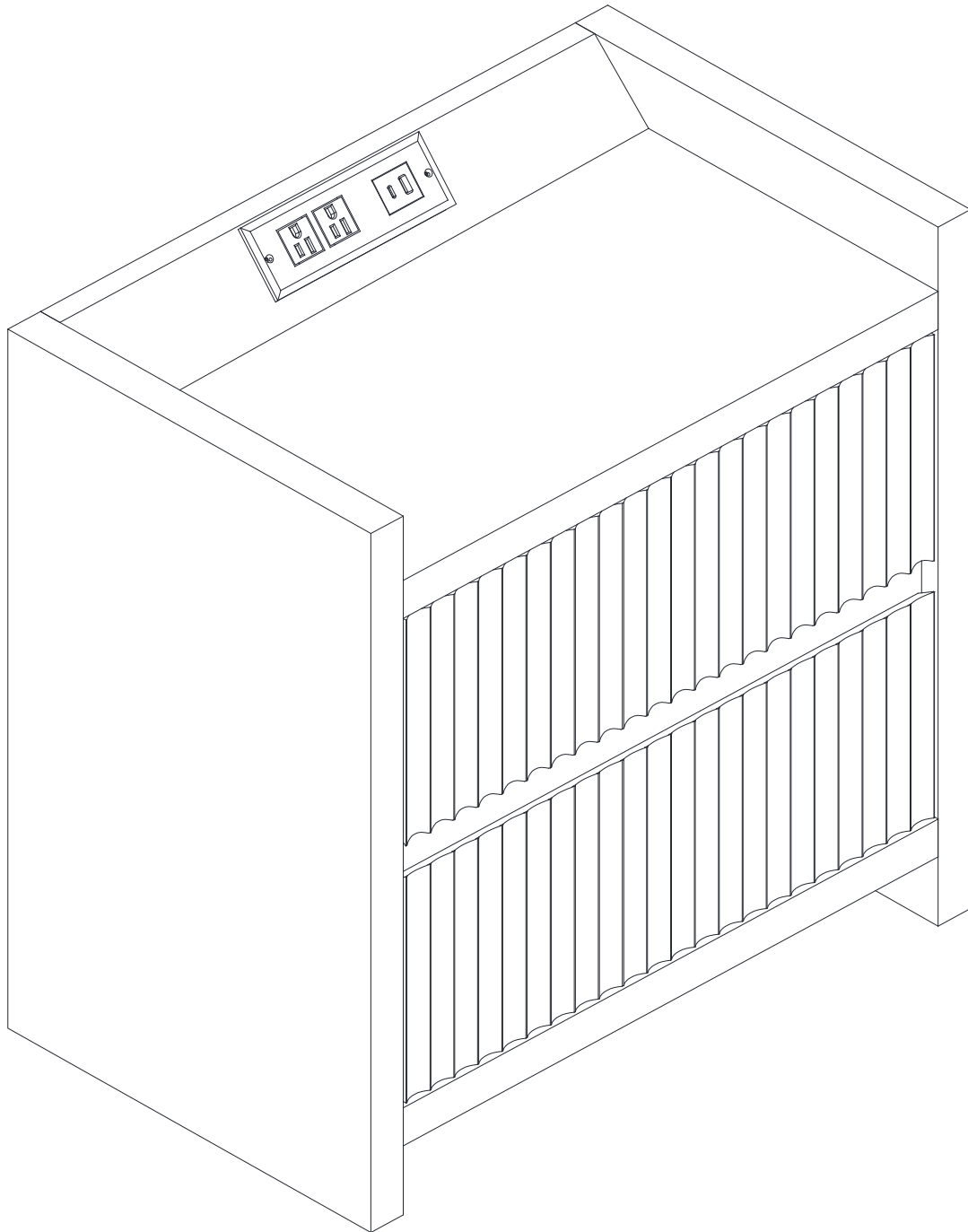

Made In China

Assembly Instructions

Before beginning the assembly process, please read and save these instructions for reference. Following these guidelines will ensure a smooth and successful assembly of your product.

1. Part Identification:

Carefully separate and identify all the parts included in your package. Confirm that you have all the components listed in the instruction manual. This step will help you avoid any missing or misplaced parts during assembly.

2. Work Surface:

To prevent any scratches or damage to the product, assemble it on a soft mat or a similar protective surface. This will provide a cushioned area for the components and protect the surfaces from unwanted marks.

3. Step-by-Step Assembly:

Follow the assembly instructions provided, proceeding one step at a time. Take care to understand each step properly before proceeding to the next one. This sequential approach ensures that the assembly is done correctly and minimizes the chance of errors.

4. Proper Screw Seating:

When attaching screws and nuts, it is essential not to fully tighten them until all screws are correctly seated. By partially tightening each screw and nut initially, you can ensure that they are aligned properly and fit securely before final tightening.

5. Avoid Over-Tightening:

While each screw and nut should be tightened correctly, it is crucial not to over-tighten them. Over-tightening can cause damage to the product or compromise its structural integrity. Use the appropriate amount of force to secure the components without excessive tightening.

If you encounter any questions or problems during the assembly process, please do not hesitate to contact us. We strive to provide excellent customer support and will respond to your inquiries within 24 hours. Our team will offer you a suitable solution to address any concerns you may have.

SICOTAS Customer Help Center:

✉ Service@sicotas.com

🌐 www.sicotas.com

☎ 833-742-6827

Official Website:



WhatsApp:



YouTube:



Ins:









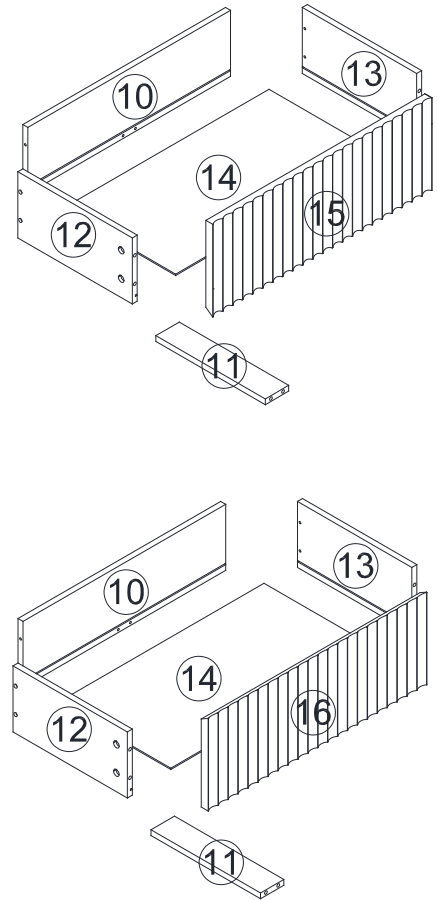
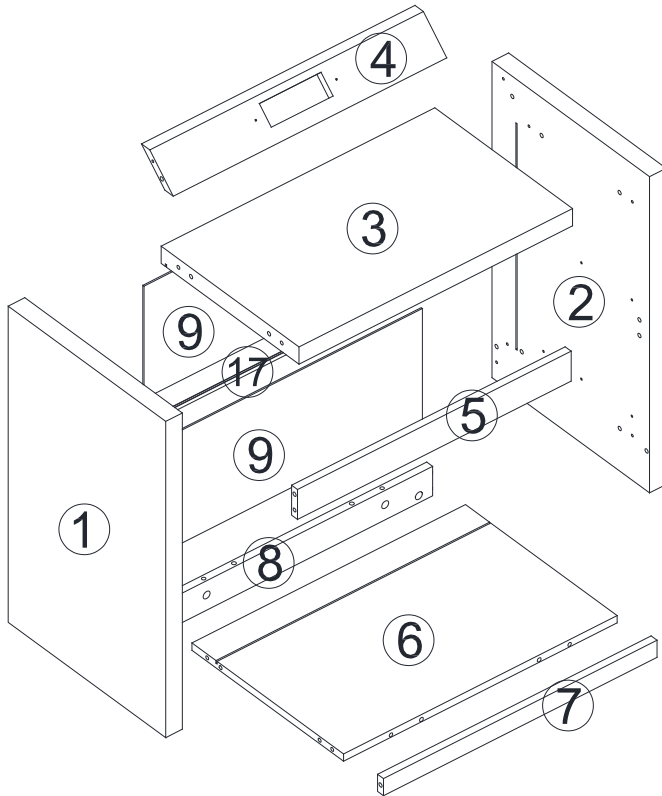



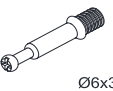



Tik Tok:



Parts List

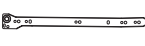

Hardware List

A x28  Ø6x35	B x28  Ø15x10	C x22  Ø8x30	D x12  M4x35	E x1 	F x2 	G x24  M3x12	H x4 
I x2  M3x12	J x8  M3x16	K x8 	L x8  M4x12	CL x2  300MM	CR x2  300MM	DL x2  300MM	DR x2  300MM

Code	Description	Quantity
A	Cam bolt	28+2
B	Cam lock	28+2
C	Ø8x30MM Wooden dowel	22+2
D	M4x35MM Screw	12+2
E	socket	1
F	angle iron	2
G	M3x12MM Screw	24+2
H	Mdjusting the footrest	4

Code	Description	Quantity
I	M3x12MM Black Screw	2+1
J	M3x16MM Screw	8+2
K	Back clip	8+2
L	M4x12MM Screw	8+2
CL	300MM Drawer runner set	2
CR	300MM Drawer runner set	2
DL	300MM Drawer runner set	2
DR	300MM Drawer runner set	2

Step 1

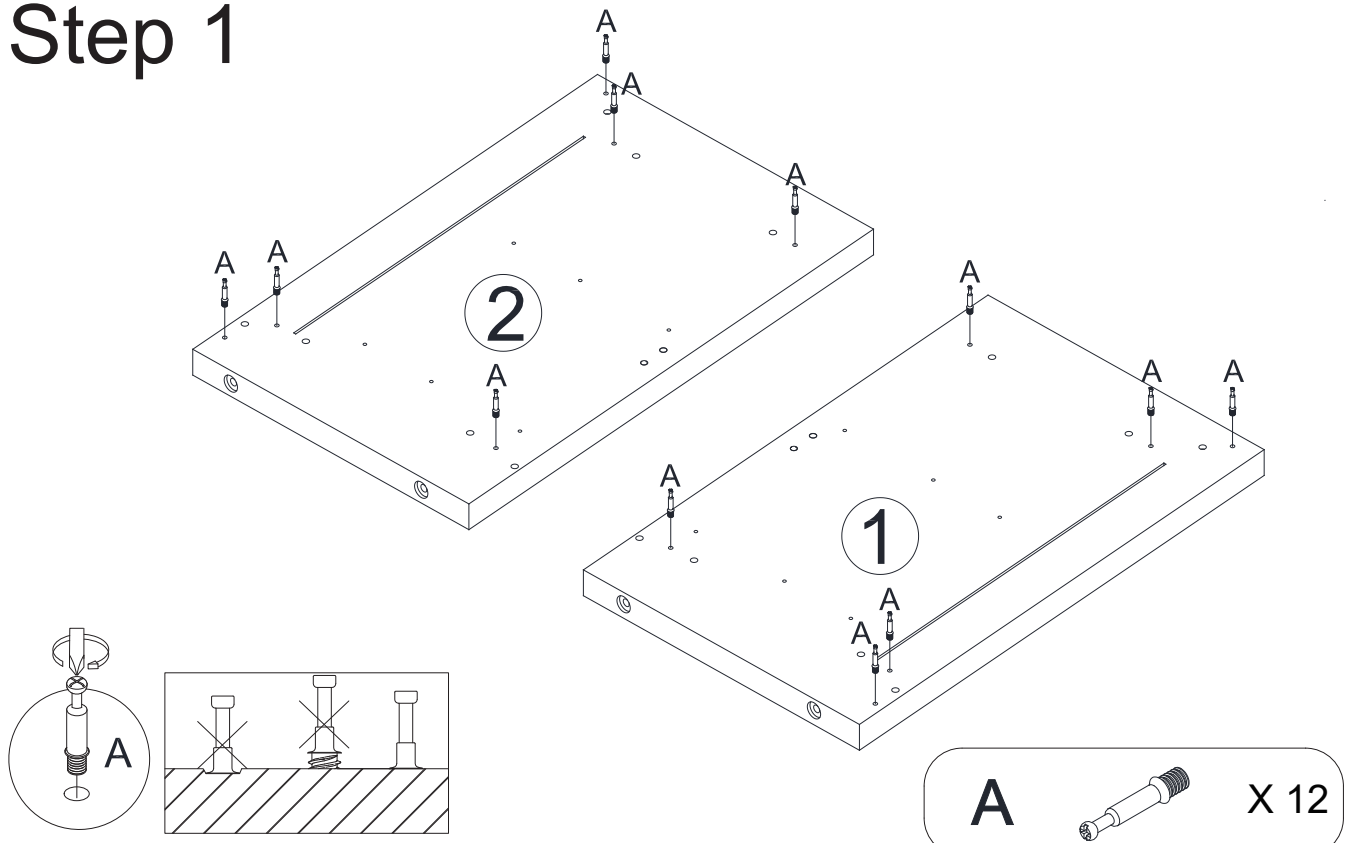

Step 2

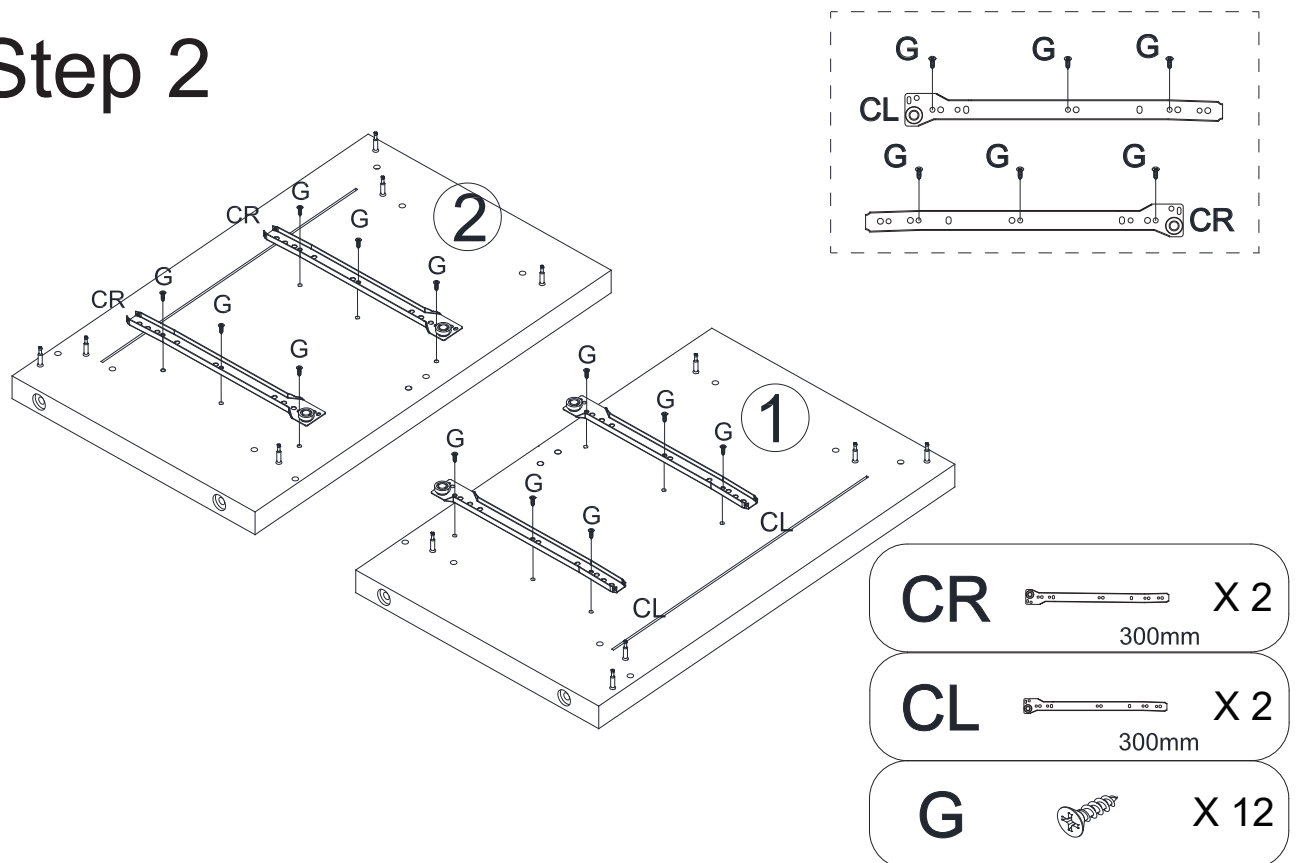

Step 3

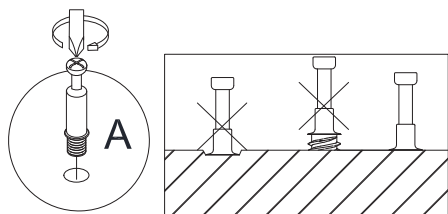
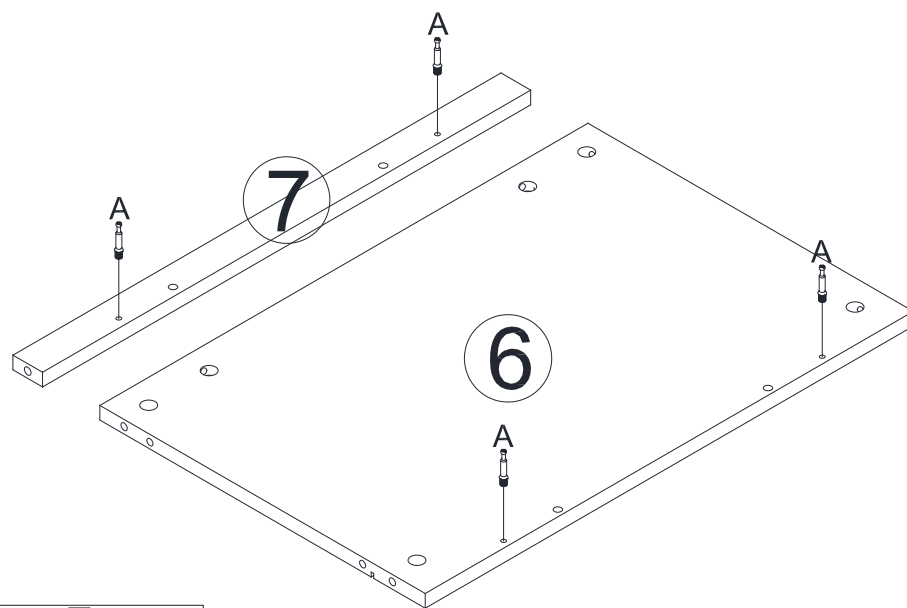

A



X 4

Step 4

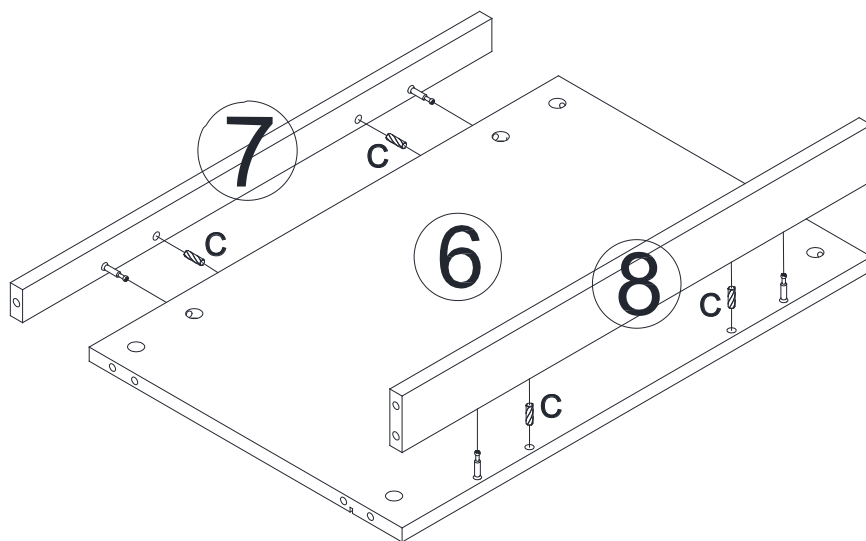

C



X 4

Step 5

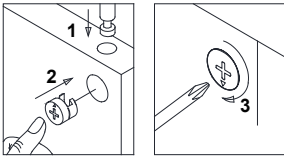
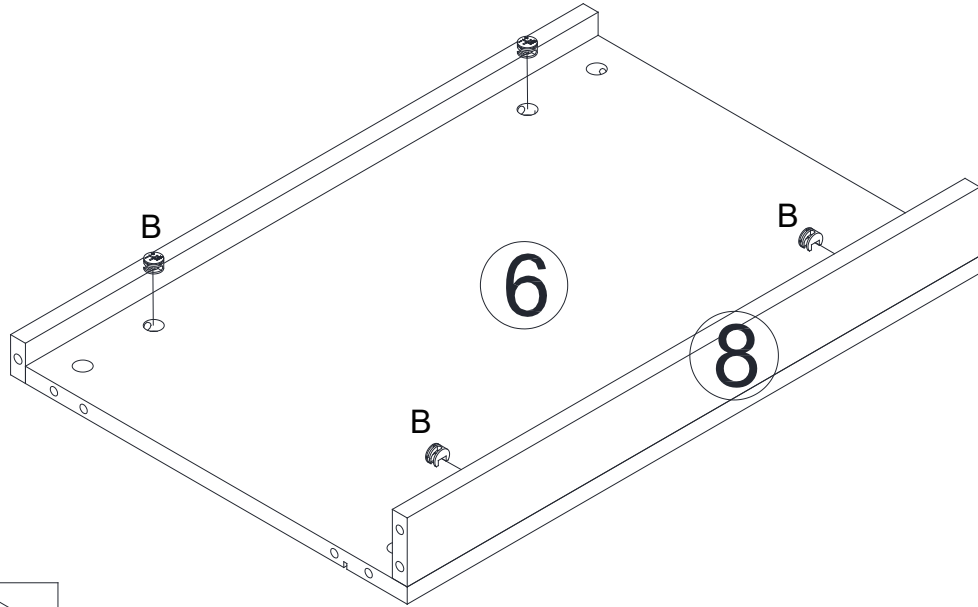

B



X 4

Step 6

Note: Part ⑤ can be selected with black or wood color surface.

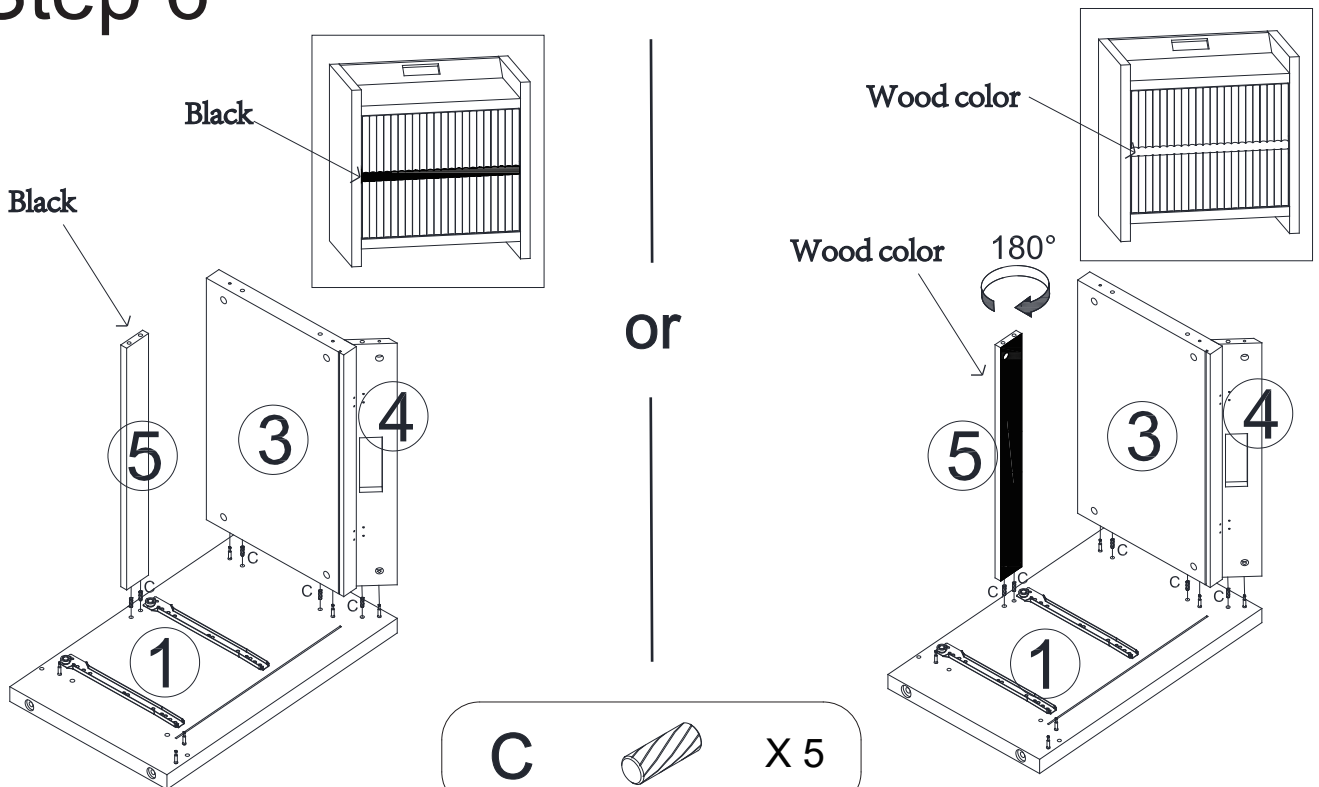

C



X 5

Step 7

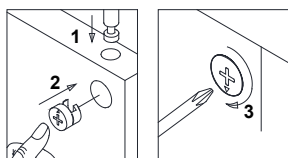
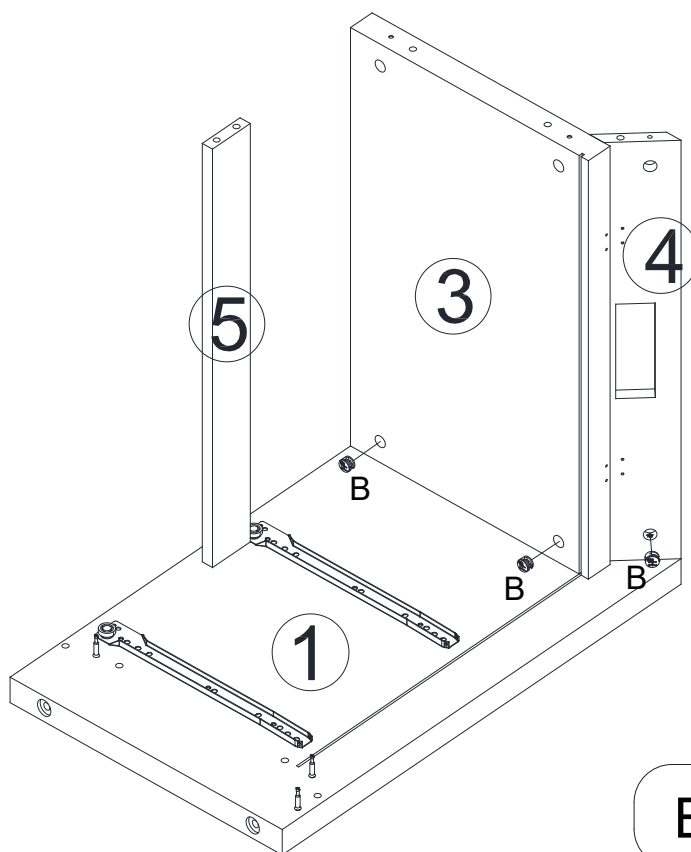

B



X 3

Step 8

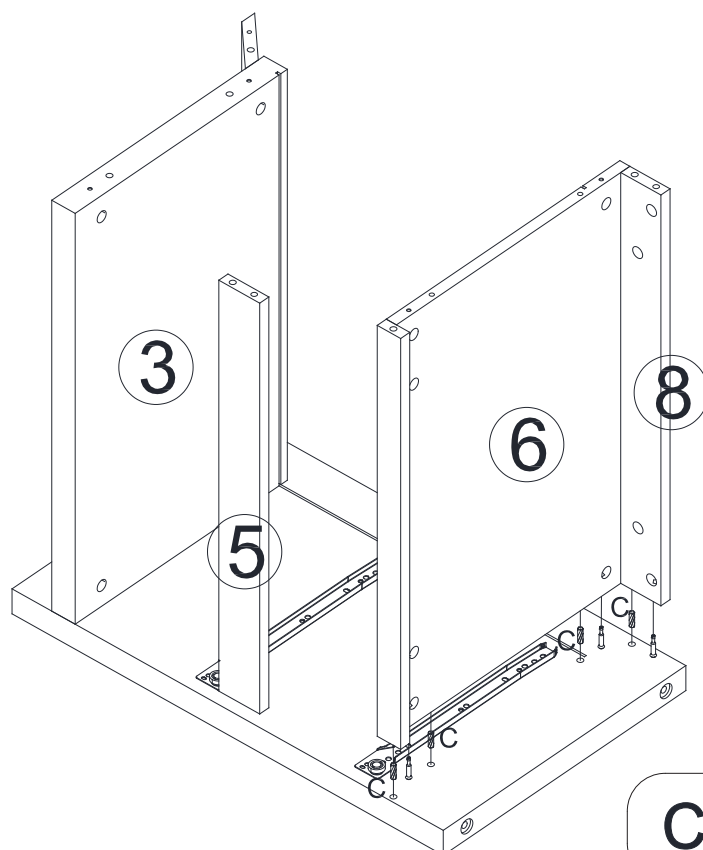

C



X 4

Step 9

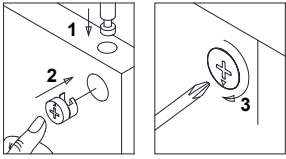
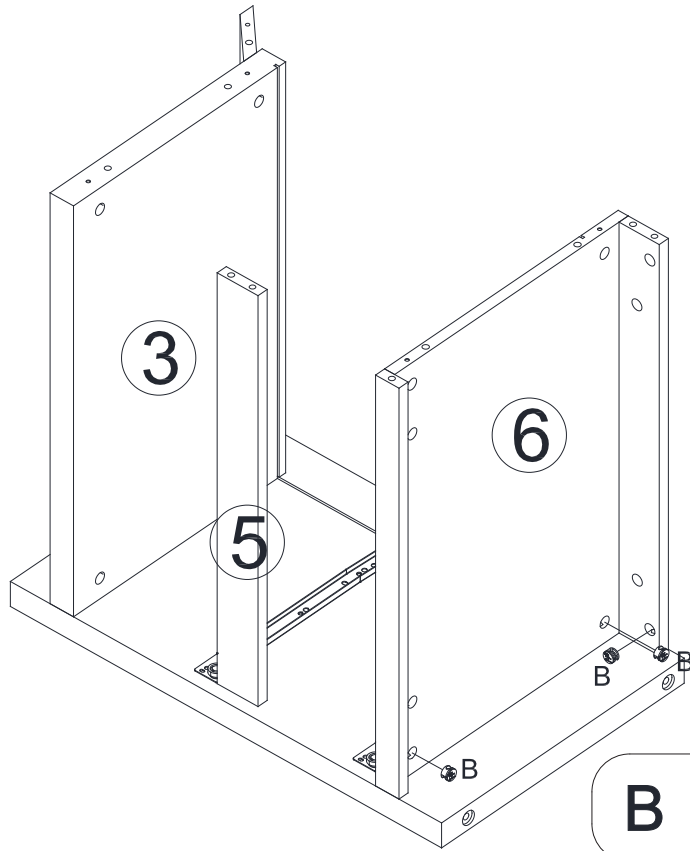

B



X 3

Step 10

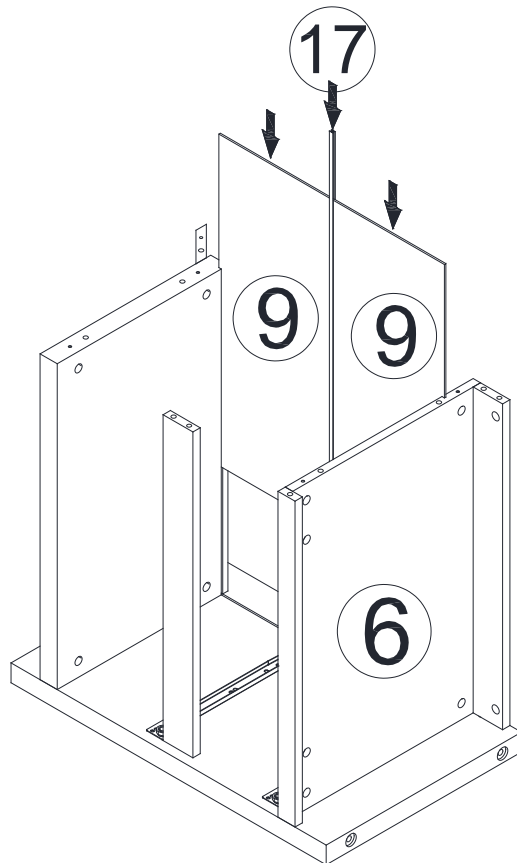

Step 11

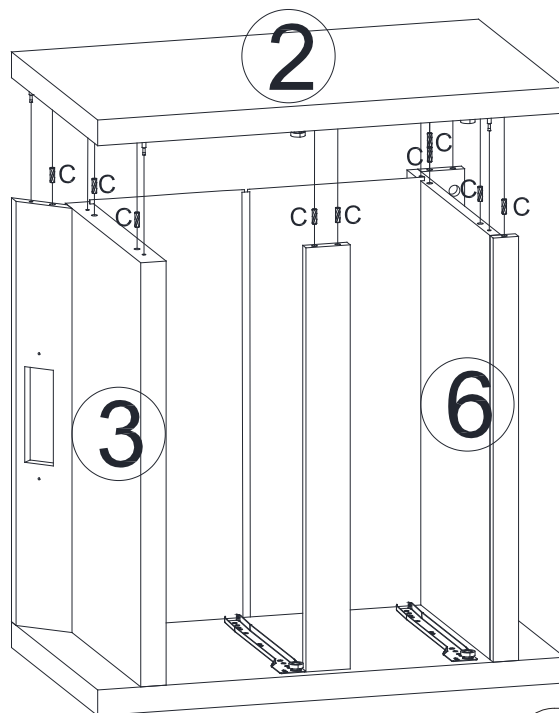

C



X 9

Step 12

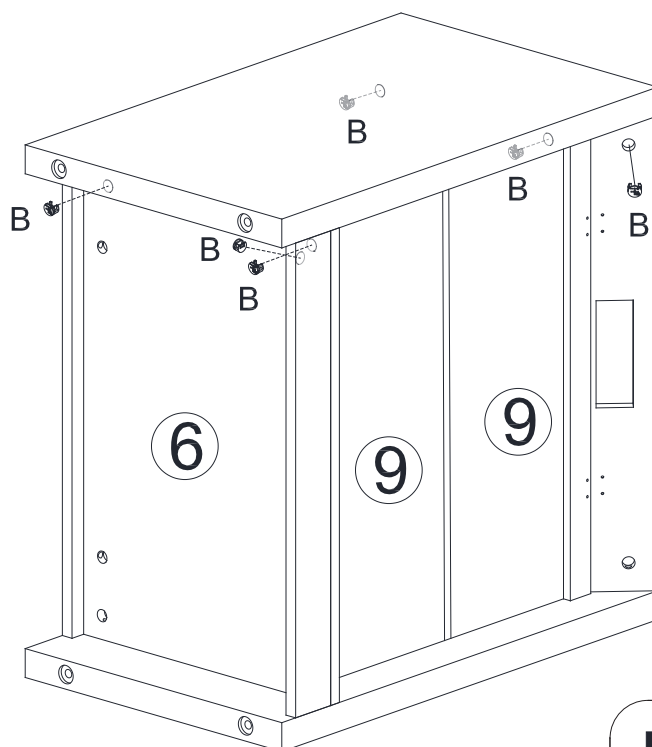

B



X 6

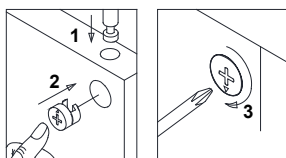

Step 13

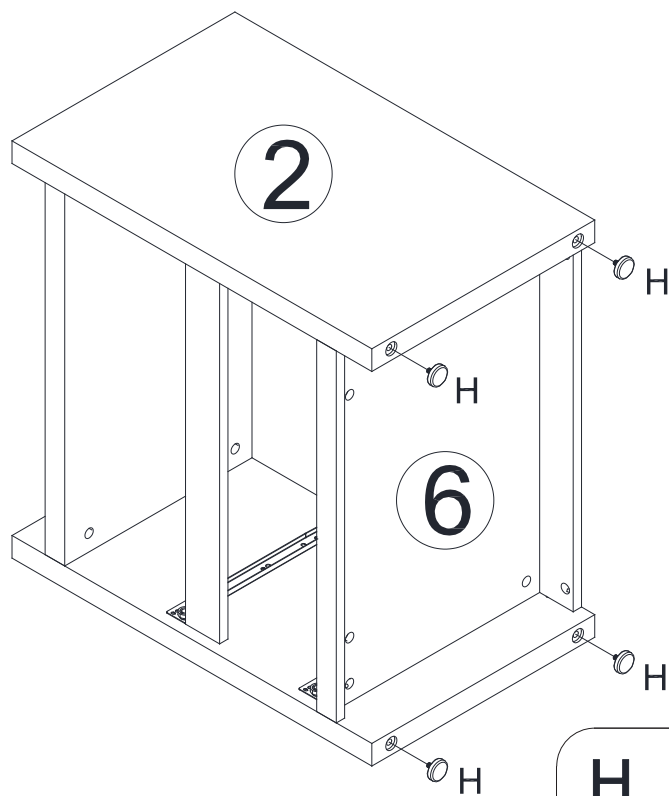

H



X 4

Step 14

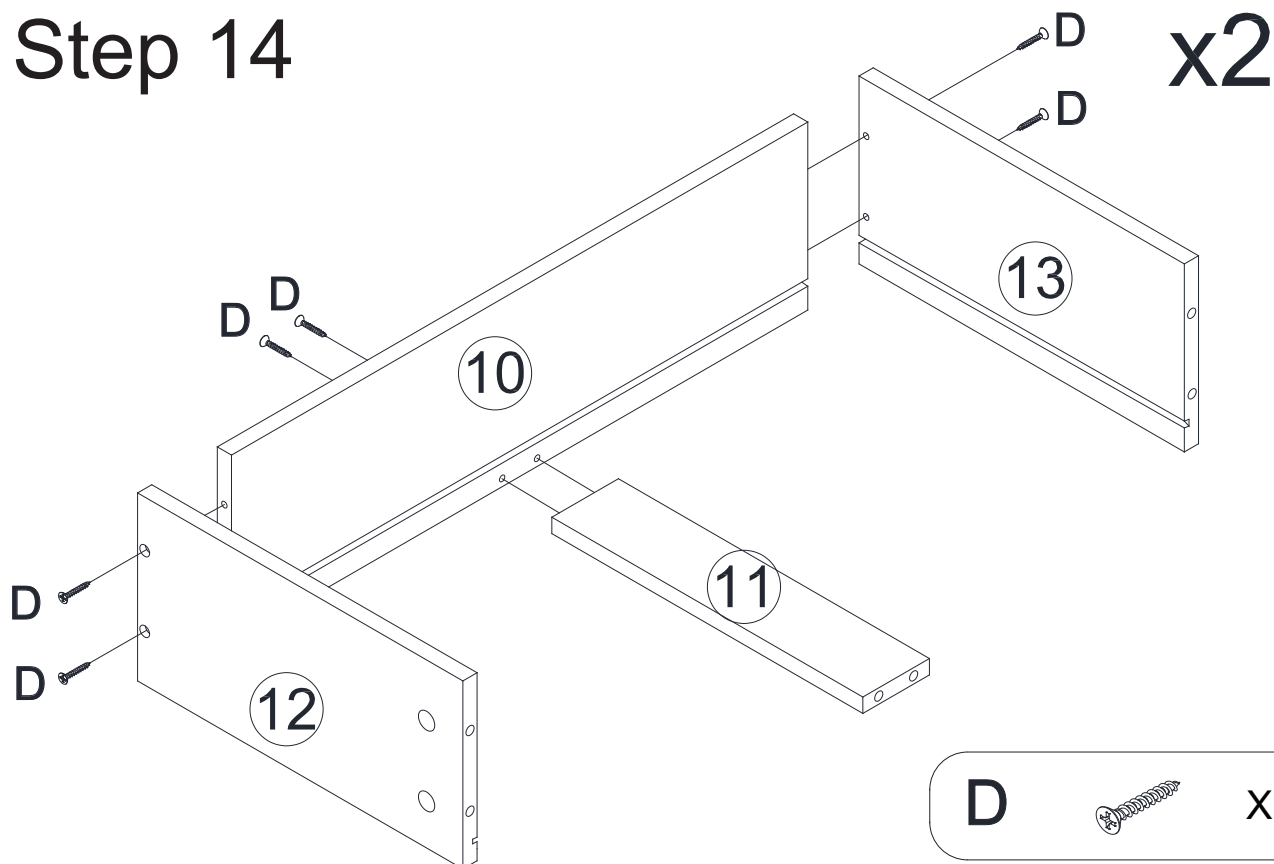

D



X 12

Step 15

x2

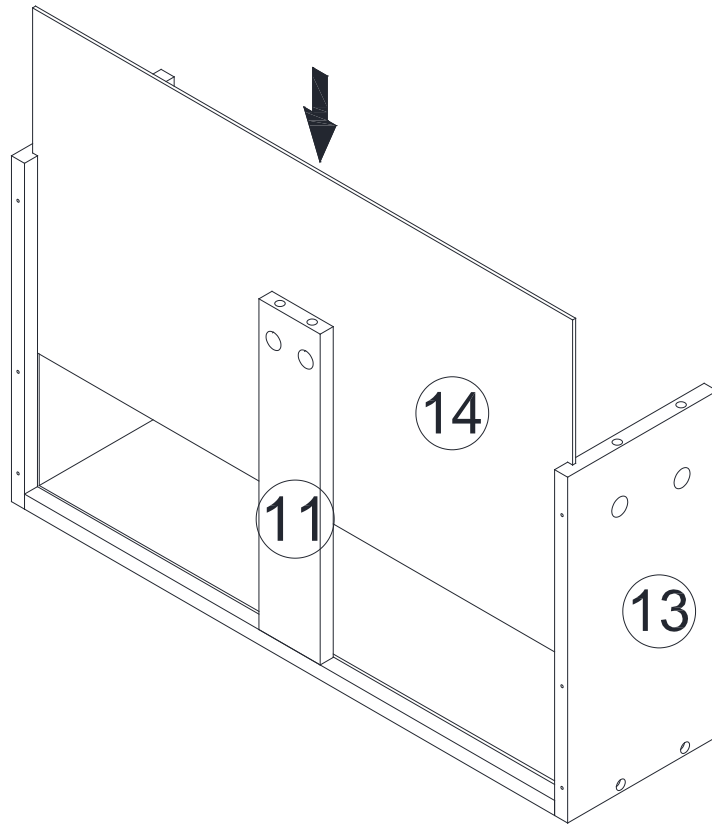

Step 16

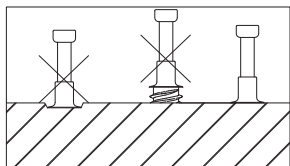
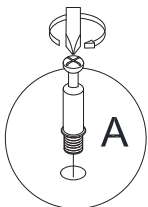
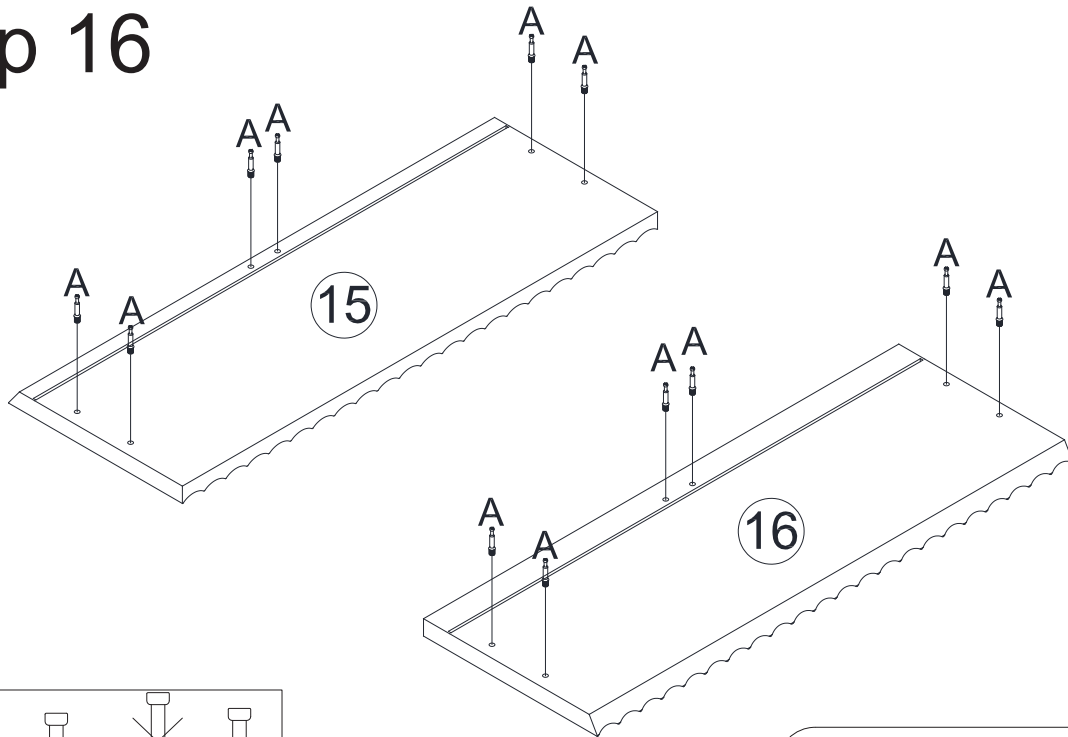

A



X 12

Step 17

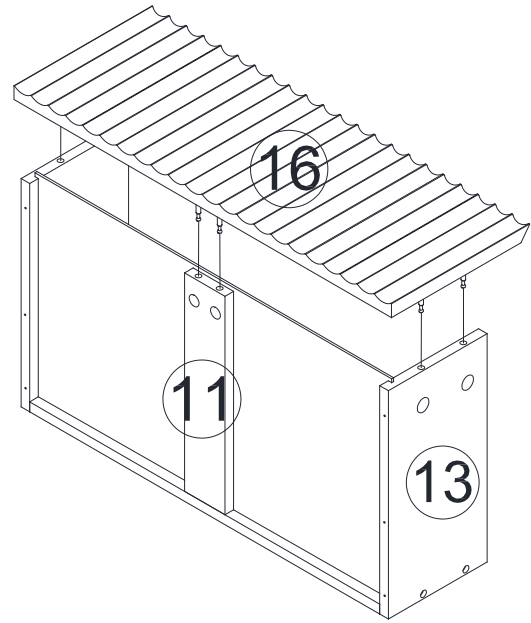
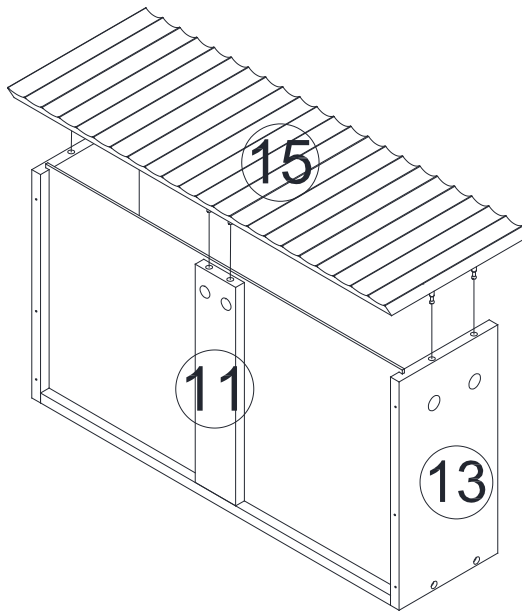

Step 18

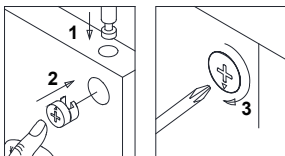
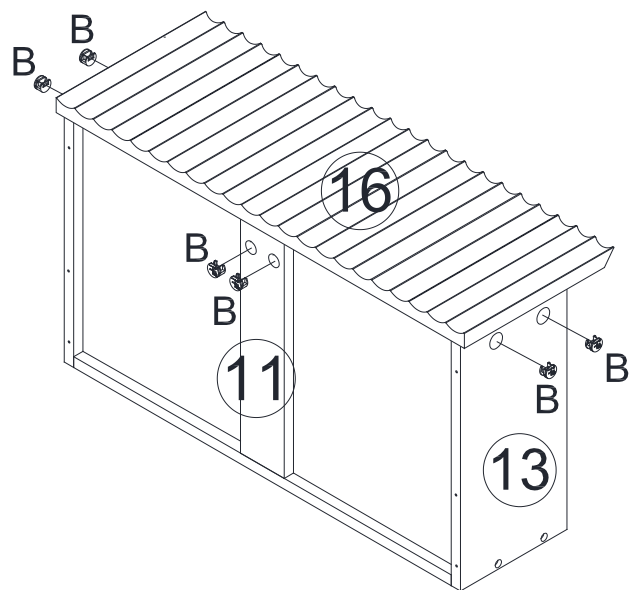
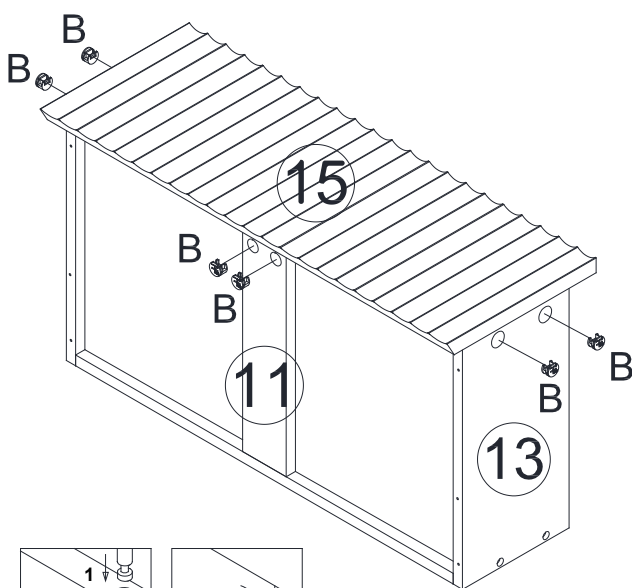

B



X 12

Step 19

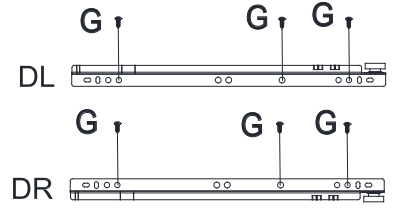
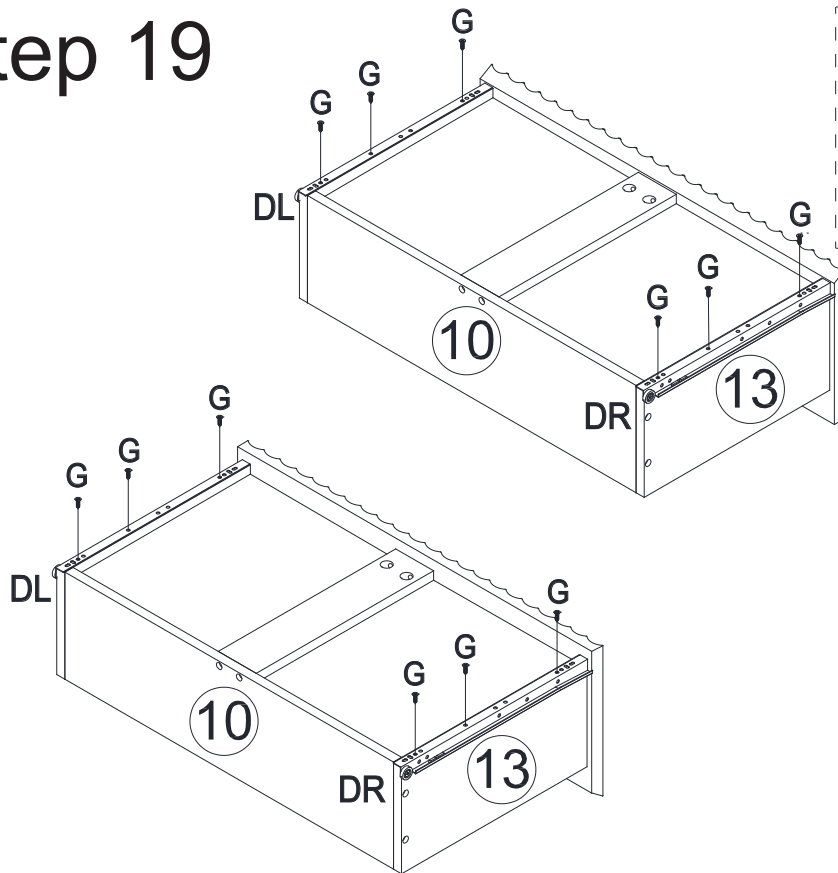



DR  X2
300mm

DL  X2
300mm

G  X 12

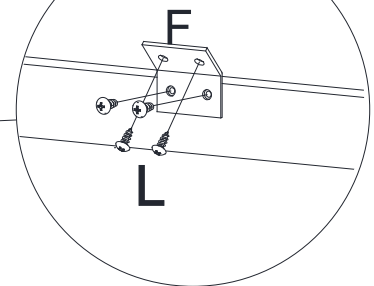
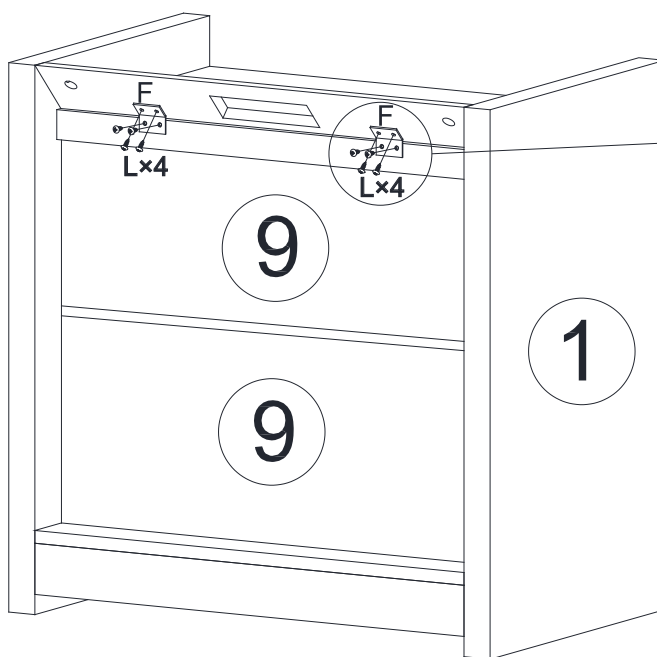
Step 20



F  X2

L  X 8

Step 21

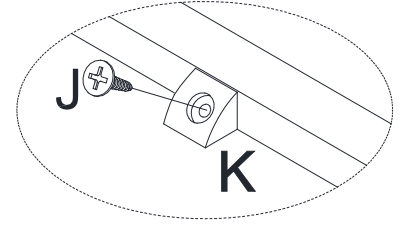
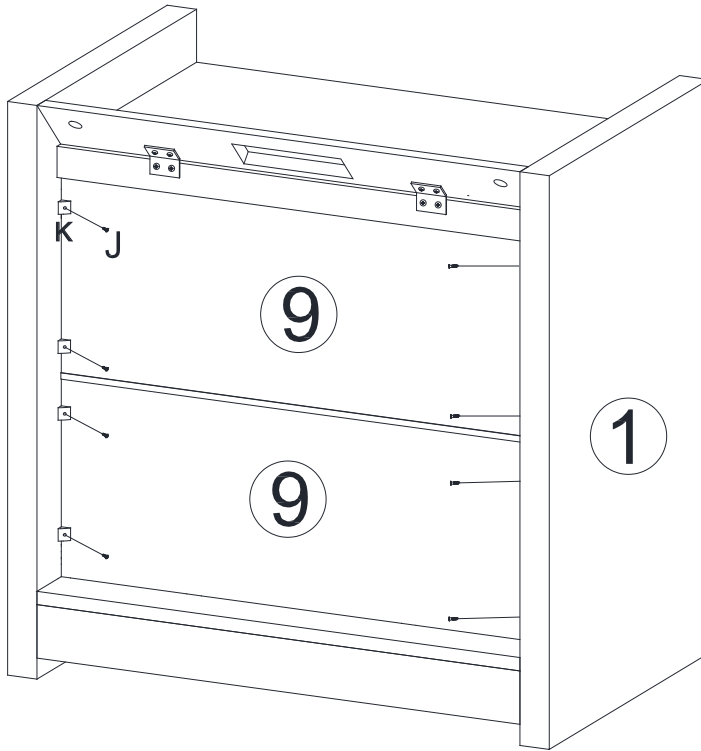

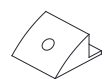

- | | | |
|----------|---|------------|
| J |  | X 8 |
| K |  | X 8 |

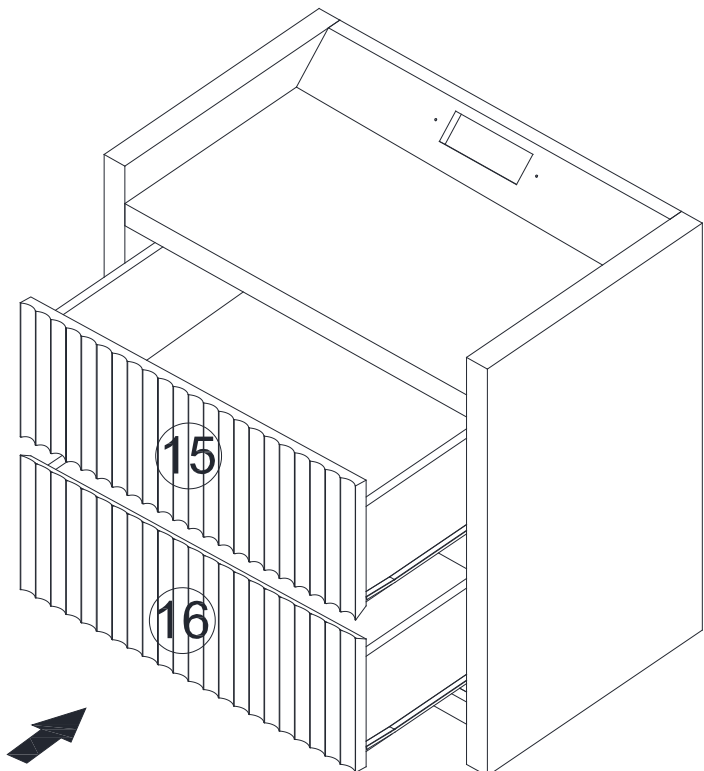
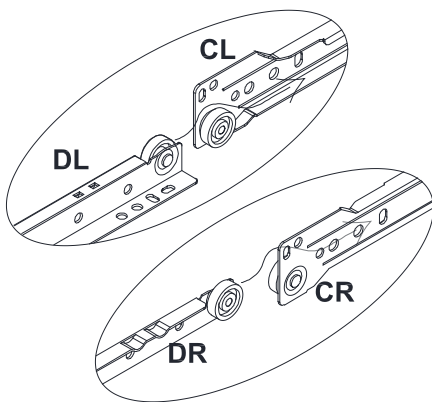
Step 22

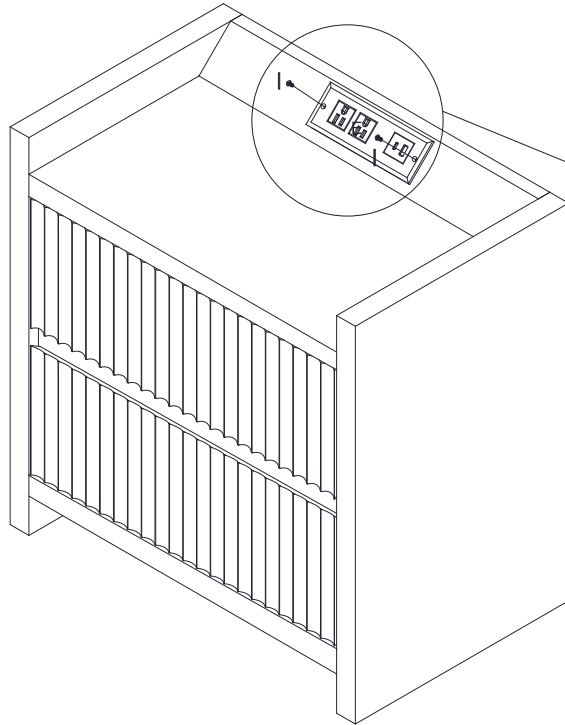

Step 23



- | | | |
|---|---|-----|
| I |  | X 2 |
| E |  | X 1 |

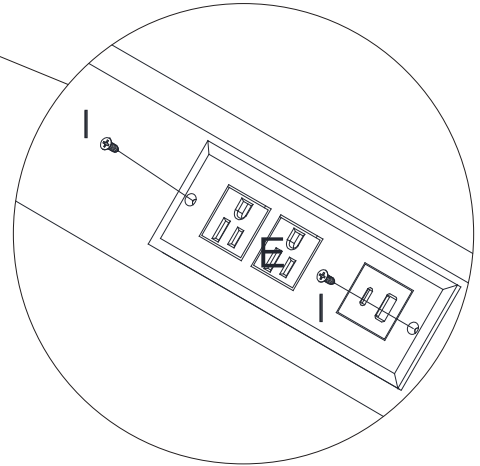

Step 24

