

Bar Stool

IMPORTANT NOTE

Carefully remove all the parts from the carton and put them individually on a soft cloth to prevent scratches or other damage occurring to the parts.

We have taken great care in the design of this product and request that you carefully and strictly follow our assembly instructions to ensure a completed product as it was designed.



Part List

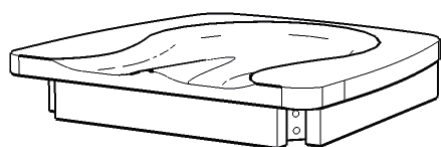

A.
Seat
1 Pc.

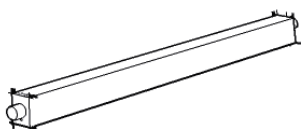

E.
Side Stretcher
1 Pc.

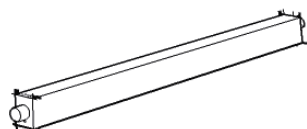

F.
Side Stretcher
1 Pc.



B.
Leg
1 Pc.



C.
Leg
1 Pc.



G.
Front Stretcher
1 Pc.

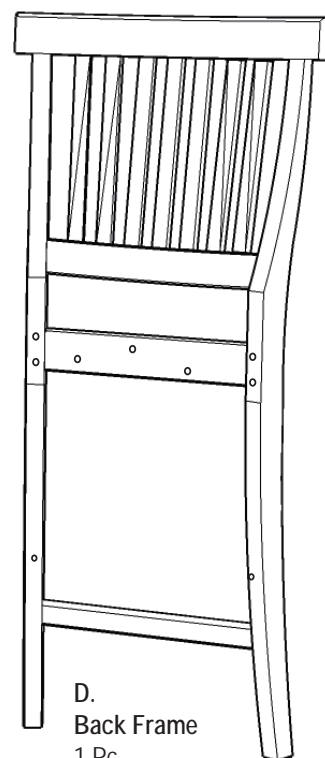

D.
Back Frame
1 Pc.

Hardware List

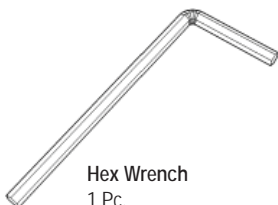

Hex Wrench
1 Pc.



Small Hex Wrench
1 Pc.



M3.5x40
Wood Screw
6 Pcs. (+1 extra)

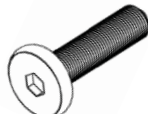

M6x40
Head Cap Bolt (short)
3 Pcs. (+1 extra)

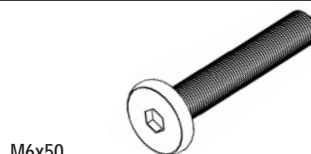

M6x50
Head Cap Bolt
4 Pcs. (+1 extra)

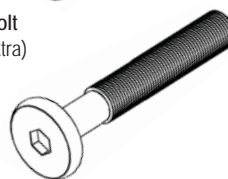

M6x70
Head Cap Bolt (long)
4 Pcs. (+1 extra)



Flat Washer
11 Pcs. (+1 extra)



Spring Washer
11 Pcs. (+1 extra)

Tools required for assembly : Phillips screwdriver

Assembly Instructions 2/2

IMPORTANT

- * Please keep Hex Wrench in a safe place as you may need to tighten up the Head Cap Bolts in the future.
- * Do not tighten up all the head cap bolts until each part is properly assembled.
- * Use a soft cloth between these parts and the floor.

STEP 1

Attach Legs (B) and (C) to Seat (A) with Flat Washers, Spring Washers and Head Cap Bolts. (See Figure 1)

Tighten Head Cap Bolts only half way.

Attach Front Stretcher (G) to unit with Wood Screws.

Attach Stretcher (E) to Leg (B) and Stretcher (F) to Leg (C) with Wood Screws. (See Figure 2)

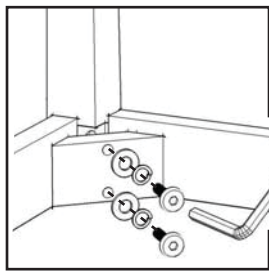
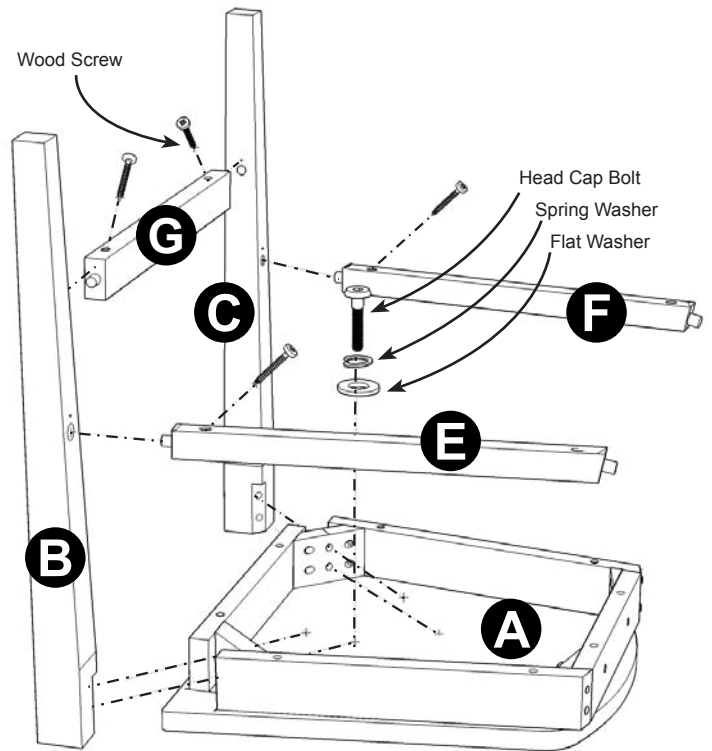

Figure 1

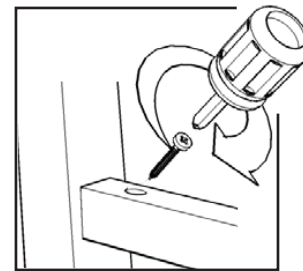

Figure 2

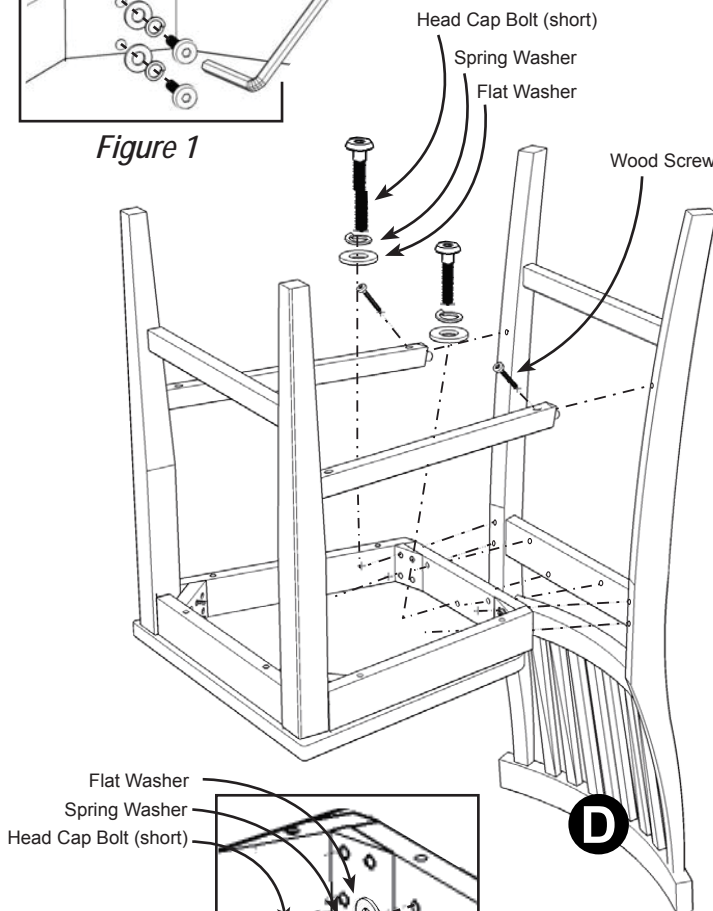

Figure 3

STEP 2

Attach Back Frame (D) to unit with Flat Washers, Spring Washers, Head Cap Bolts (short), Head Cap Bolts (long) and Wood Screws. (See Figure 3) and (See Figure 4)

Tighten all Head Cap Bolts.

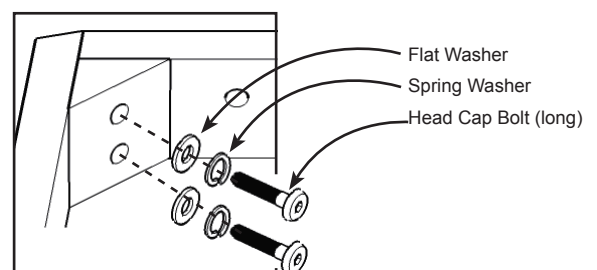

Figure 4