

LED Balance Shower Faucet Installation Manual

W-55(ES)

Warranty Duration

All parts of this faucet system are warranted to the original purchaser to be free from defects in material and workmanship for a lifetime.

Repair and Replacement

If the product has defects in material and workmanship within the warranty period, we will repair or replace the product free of charge. However, you may be required to provide the invoice when requesting repairs or replacement from us.

Exclusions

We shall not be responsible for the following cases:

- Damage to the product caused by improper installation, misuse, unauthorized repair or replacement, or abuse (including damage during shipment).
- Damage to the product caused by improper dismantlement after installation.
- Damage resulting from abnormal water pressure and impurities in water pipes is not covered under this warranty.
- Rust on the product due to insufficient care and maintenance is not covered under this warranty.
- Damage caused by natural disasters such as fire, flood, earthquake, electric storms, etc., is not covered under this warranty.

I hope this helps! If you have any further questions or concerns, please let me know.

Having Trouble? Contact us.

✉ Email: info@faucetsupport.com

☎ Toll Free: 1-888-969-6880



CEC **FC** **CE** **RoHS**



M6487
SFS-1010

CONTENT

1.Three-function Rain Shower System ----- (1-7)

CONTENIDO

1.Sistema de ducha de lluvia de tres funciones----- (8-14)

◆ Installation and maintenance matters

1. Check the accessories list to verify that all parts are complete in this package.
2. Do not disassemble the main body by yourself.
3. Connect inlet pipes to supply valves.
4. Make sure inlet pipes and supply valves have no impurities and are cleaned, with no impurities in the pipeline.
5. After installation, check all joints for leakages.
6. Do not leave the rain shower system exposed to a severely corrosive environment.

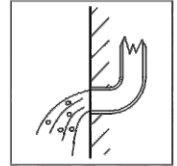
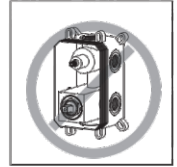

Do's

1. In order to keep the mixer surface bright, please clean the mixer regularly.
2. Rinse the faucet with clean water and wipe it with a soft cotton cloth.
3. Use one of the following cleaners to remove dirt from the surface:
 - a. Mild liquid cleaner.
 - b. Colorless glass cleaner and powder cleaner that do not cause abrasion and can be dissolved completely.
 - c. Polish liquid that does not cause abrasion.

Don'ts

- a. Avoid using cleaning powder, harsh cleaning chemicals, brushes and coarse cloth to prevent scratching and friction.
- b. Do not use acid cleaners to clean the faucet as they may cause surface corrosion of the faucet. If the faucet is exposed to harmful acid substances, please rinse it immediately with water.

TOOLS NEEDED:

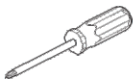

◆ 3-Function Luxury Shower Faucet

Model:A

Accessories List

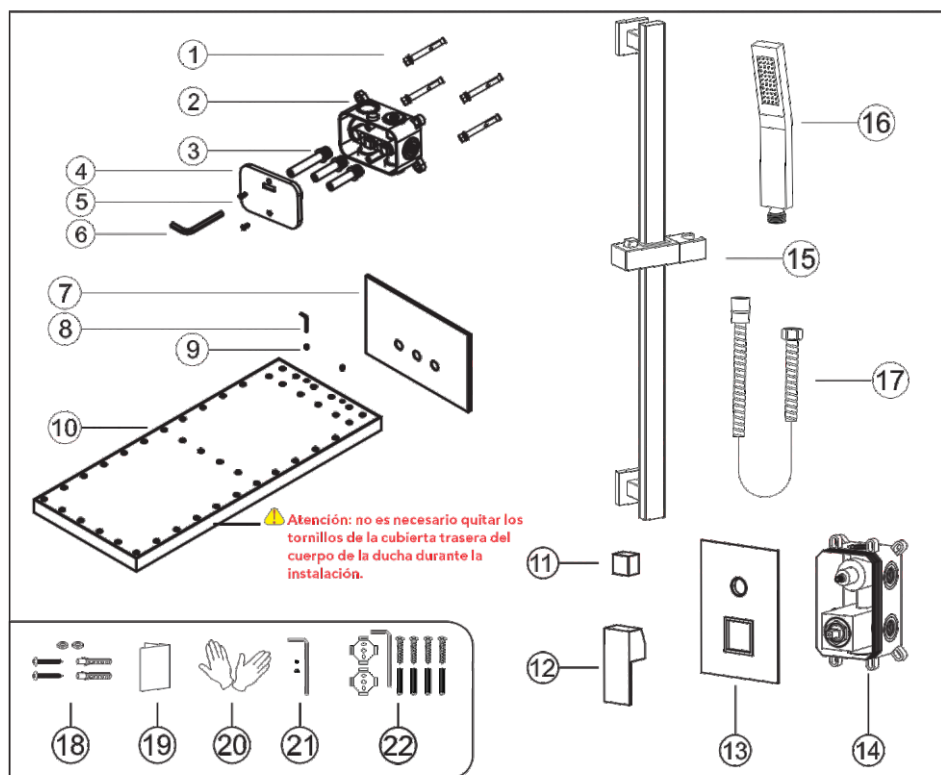

No.	Part name	Qty	No.	Part name	Qty
1	Expansion screws	4	12	Handle	1
2	Inwall box	1	13	Deck plate	1
3	Water inlet	3	14	Main body	1
4	Cover	1	15	Lifting rod	1
5	Screw	2	16	Handle	1
6	S8 Allen key	1	17	Shower hose	1
7	Flange	1	18	Main body spare parts	4
8	Allen key 2.5	1	19	Instruction manual	1
9	M4 screw	2	20	Gloves	2
10	Shower head body	1	21	Handle parts	1set
11	Water diverter	1	22	Lifting rod parts	1set

◆ Essential dimensions & water pipe line

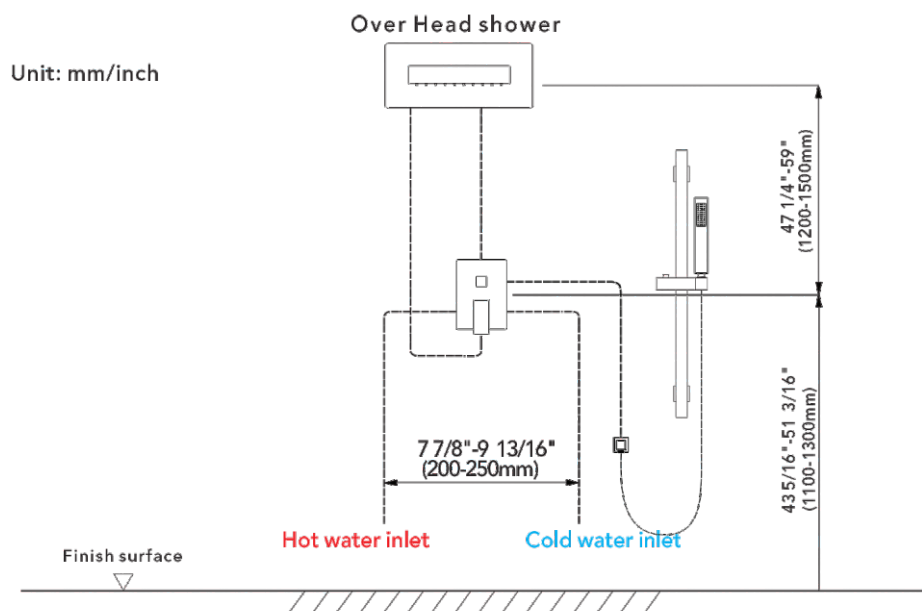

◆ Piping Instructions Before Tiling

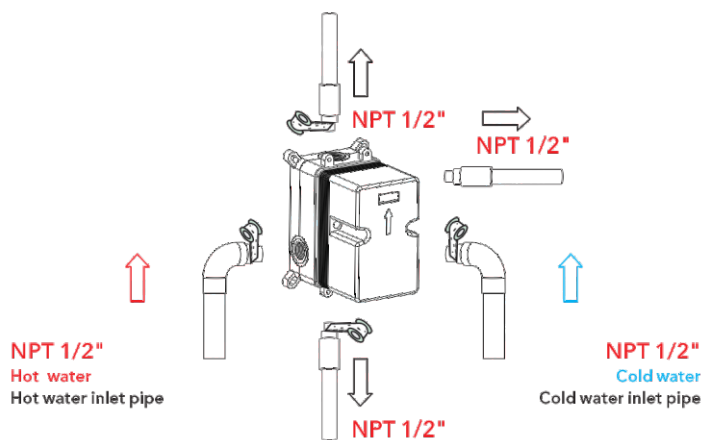

1. As shown in the figure, the inlet and outlet pipes are pre-buried. Please pay attention to the correct direction when installing the pre-buried main body.
2. Before tiling, turn on the water to test whether the left and right inlet pipes are tightly connected without leakage. Then, adjust the flow switch to the "on" position to check for leaks in the mixed outlet pipes.

◆ Installation Depth Of Main Body

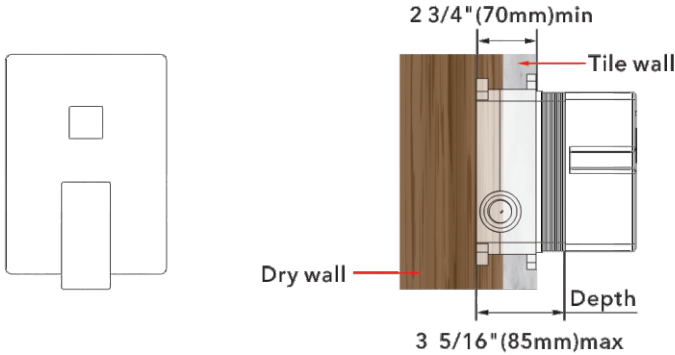

- Notice: 1. The installation depth of the main body should be no less than 2 3/4" (70mm) and no more than 3 5/16" (85mm), including the thickness of the tile. Otherwise, the deck plate cannot be installed.
2. The opening size of ceramic tile shall be smaller than the deck plate size.

◆ Main Body Valve Installation(Model :A&B)

Step1

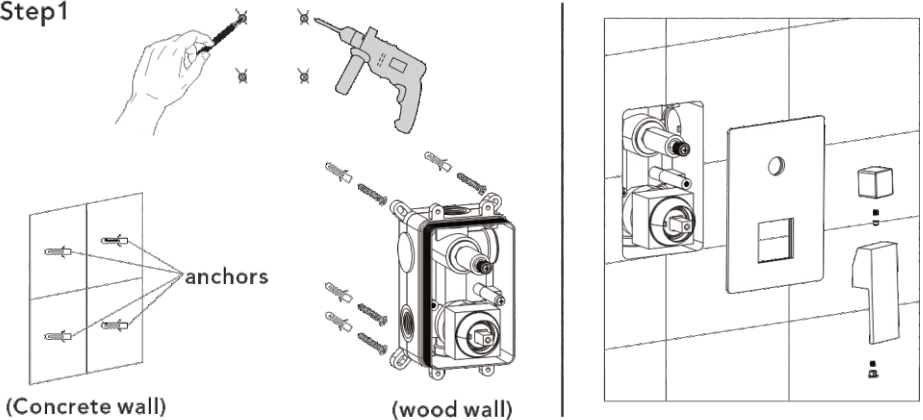

(Concrete wall)

(wood wall)

1. Make marks according to the size of the main body valve, and then drill anchors into the wall (concrete wall).
 2. Lock the main body to wood directly with screws (wood wall).
 3. When installing the main body, please mark the UP side up and do not install it upside down.
- ▲ Please note that the level meter should be parallel to the wall; otherwise, the deck plate cannot be installed.

◆ Main Body Water Outlet Switch Control

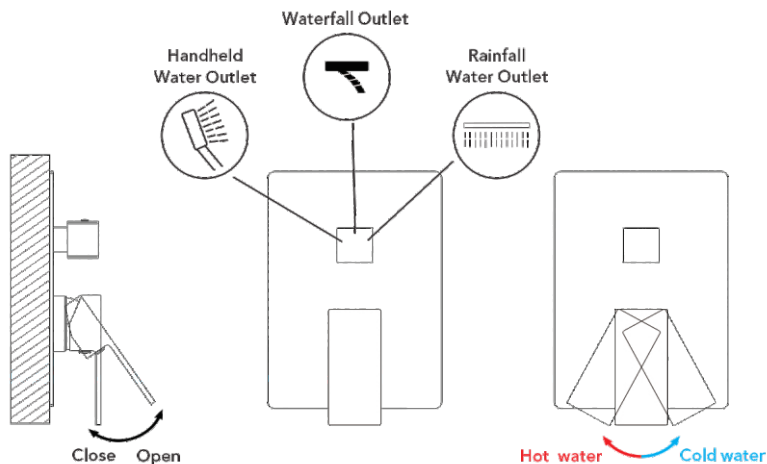

1. Open the water valve and check for any leakage
2. Turn the handle upwards to open the water valve. The turning angle can control the water outflow rate. Then, the user can turn it to the left or right to control the water temperature, where the left is for hot water and the right is for cold water.
3. The switch valve can alternate the water outlet between the shower head, body jet, and handheld shower

◆ Lifting Rod Installation

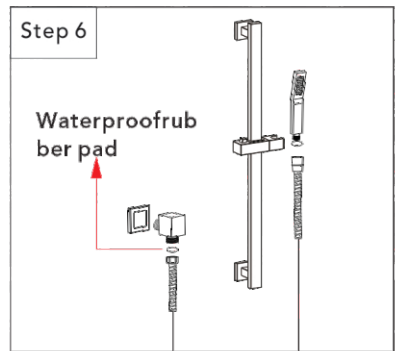
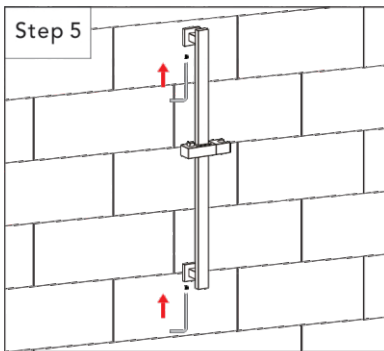
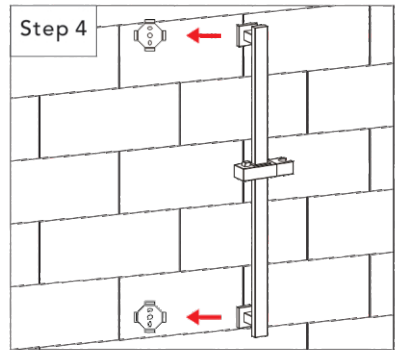
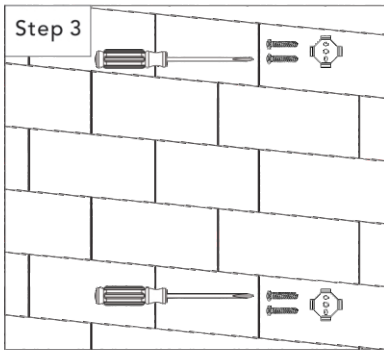
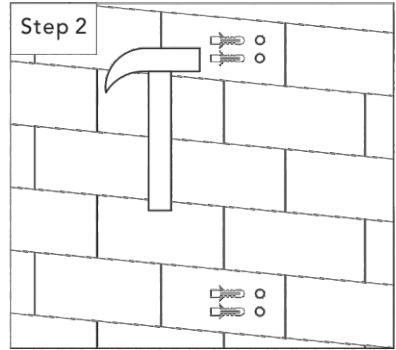
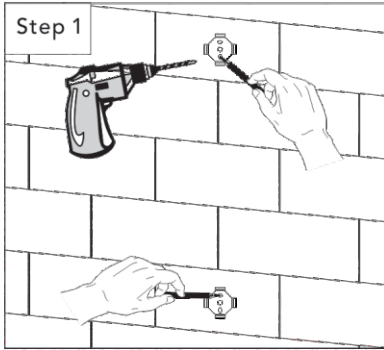

1. Mark the punch position with a pen, drill holes using a 6 mm electric drill, then knock the pellets in. Lastly, place the base and screw in the screws.

2. Put the Shower Elevator Rack into the base, then tighten the screw. Done.

Step 1. Wrap the connector with Teflon tape. Screw the thread into the water pipe inside the wall.

Step 2. Install the rubber pad on the shower hose and connect it to the connector.

◆ 22-Inch Shower Head Installation

1. Digging wall according to following size, and connect rain and waterfall inlet correctly

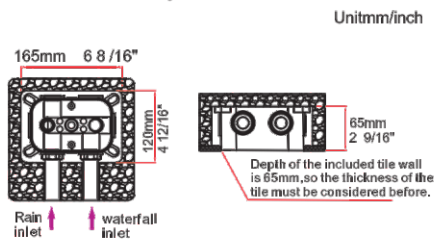

- ⚠ If the Inwall box is embedded too deep, the shower head will not be installed properly and it will cause water leakage and sag problems. Please pay attention to the installation depth.

2. Lock Inwall box refer to level meter guarantee horizontal level and test leaking for 24 hours.

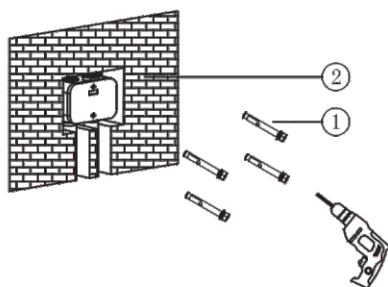

3. Remain inwall box in same level as wall after seal the tile and cover exceed wall.

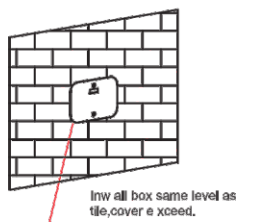

4. Install Shower head body. First remove box cover and plug, screw three water inlets into inwall box with S8 Allen Key. Longes role is support.

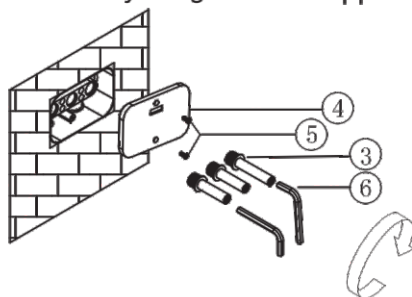

5. Install Flange as picture.
Caution: do setp 4-5-6 to test horizontal and vertical position of shower head before wall seal to avoid any trouble of repair after wall seal.

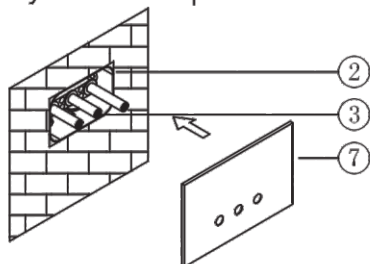

6. Push shower head body into according water inlets, and tighten shower body by M4 screw with Allen key 2.5.

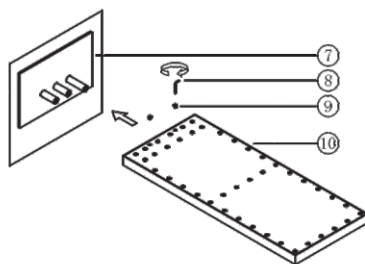

◆ Instalación y cuestiones de mantenimiento

1. Verifique la lista de accesorios para comprobar que todas las partes están completas en este paquete.
2. No desmonte el cuerpo principal por sí mismo.
3. Conecte las tuberías de entrada a las válvulas de suministro.
4. Asegúrese de que las tuberías de entrada y las válvulas de suministro no tengan impurezas y estén limpias, sin impurezas en la tubería.
5. Después de la instalación, verifique todas las uniones para detectar fugas.
6. No deje el sistema de ducha tipo lluvia expuesto a un ambiente severamente corrosivo.

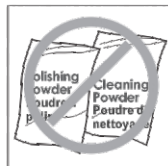
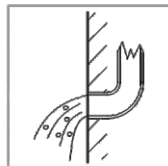
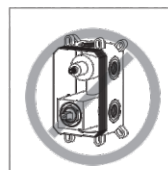

Hacer

1. En para mantener la superficie de la batidora brillante, limpie el mezclador regularmente.
2. Inse el grifo con agua limpia y límpielo con un suave ropa de algodón.
3. Utilice uno de los siguientes limpiadores para eliminar la suciedad de la superficie: a. Limpiador líquido suave. b. Limpiador de vidrio incoloro y limpiador en polvo que no causen abrasión y que se puedan disolver completamente. c. Líquido pulidor que no cause abrasión.

No es decir

- A. Valte con polvo de limpieza, productos químicos de limpieza duros, cepillos y tela gruesa para evitar rascar y fricción.
- B. No use limpiadores de ácidos para limpiar el grifo, ya que pueden causar corrosión superficial del grifo. Si el grifo está expuesto a sustancias ácidas dañinas, enjuague inmediatamente con agua.

HERRAMIENTAS NECESARIAS:

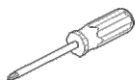

◆ Sistema de Ducha de Lluvia con Tres Funciones

Modelo: A

Lista de Accesorios

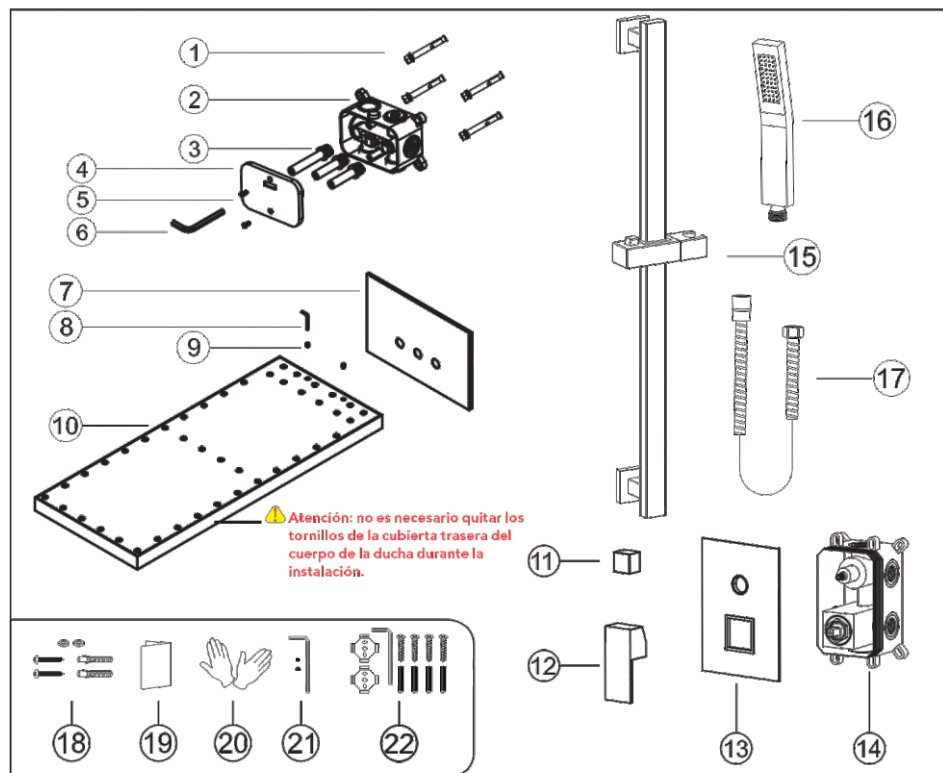

N.º	Nombre de la pieza	Cantidad	N.º	Nombre de la pieza	Cantidad
1	Tornillos de expansión	4	12	Manija	1
2	Caja empotrada	1	13	Placa de cubierta	1
3	Entrada de agua	3	14	Cuerpo principal	1
4	Cubierta	1	15	Barra de elevación	1
5	Tornillo	2	16	Ducha de mano	1
6	Llave Allen S8	1	17	Manguera de ducha	1
7	Brida	1	18	Repuestos del cuerpo principal	4
8	Llave Allen 2.5	1	19	Manual de instrucciones	1
9	Tornillo M4	2	20	Guantes	2
10	Cuerpo del cabezal de la ducha	1	21	Piezas de la manija	1set
11	Desviador de agua	1	22	Piezas de la barra de elevación	1set

◆ Dimensiones esenciales & línea de tubería de agua

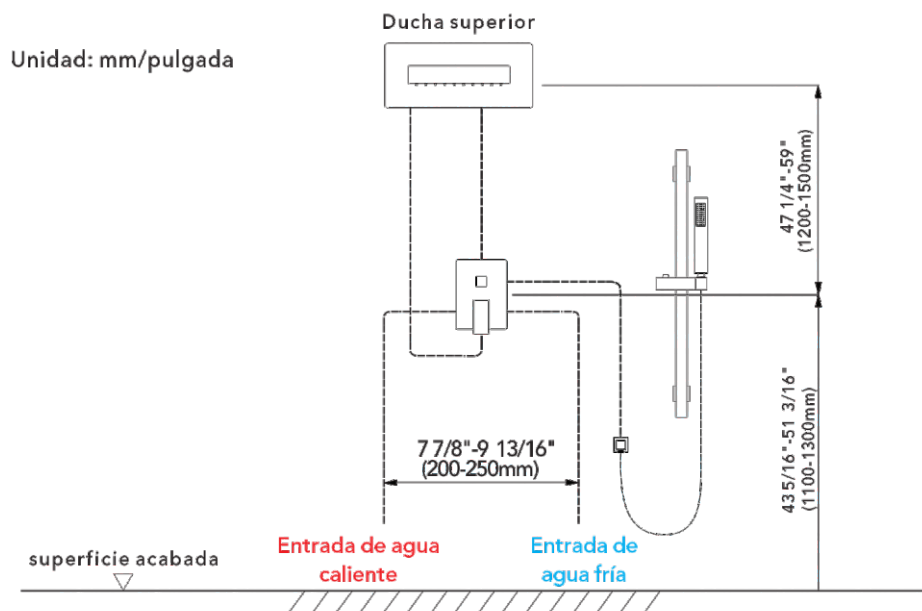

◆ Profundidad de Instalación del Cuerpo Principal

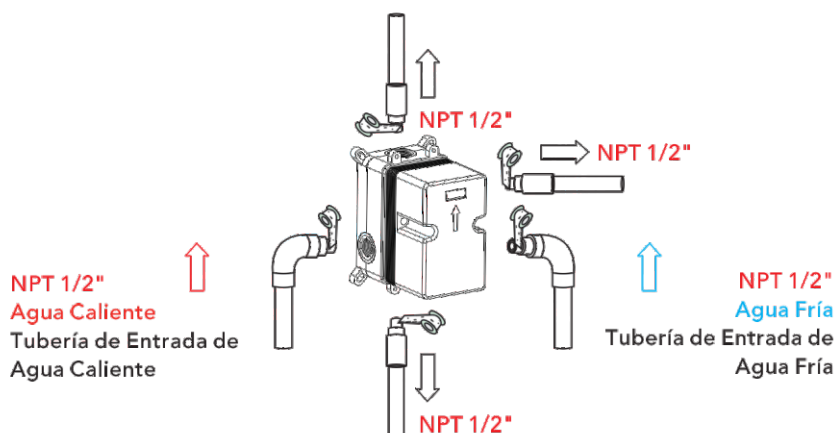

1. Como se muestra en la figura, las tuberías de entrada y salida están preenterradas. Preste atención a la dirección correcta al instalar el cuerpo principal preenterrado.
2. Antes de colocar los azulejos, abra el agua para probar si las tuberías de entrada izquierda y derecha están conectadas sin fugas. Luego, ajuste el interruptor de flujo a la posición "encendido" para verificar si hay fugas en las tuberías de salida mezcladas.

◆ Profundidad de instalación del cuerpo principal

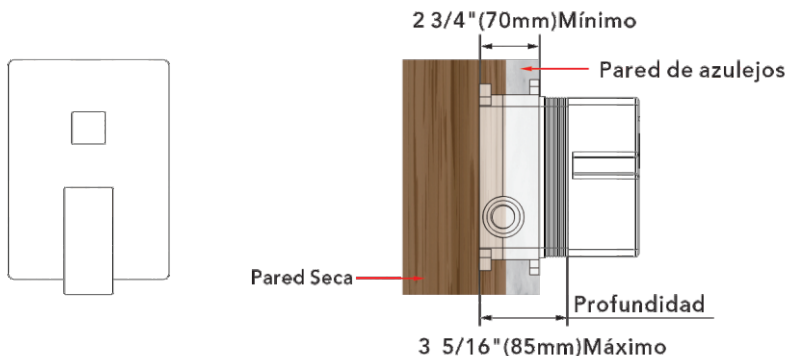

Aviso:

1. La profundidad de instalación del cuerpo principal debe ser no menor a $2\frac{3}{4}$ " (70mm) y no mayor a $3\frac{5}{16}$ " (85mm), incluyendo el grosor del azulejo. De lo contrario, no se podrá instalar la placa de cubierta.
2. El tamaño de apertura del azulejo debe ser menor que el tamaño de la placa de cubierta.

◆ Instalación de la Válvula del Cuerpo Principal

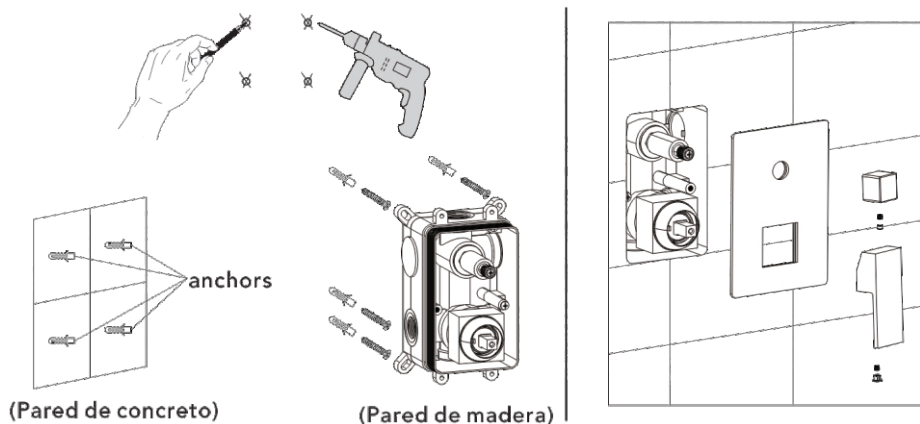

1. Haga marcas según el tamaño de la válvula del cuerpo principal y luego taladre anclajes en la pared (pared de concreto).
2. Fije el cuerpo principal a la madera directamente con tornillos (pared de madera).
Al instalar el cuerpo principal, marque el lado superior hacia arriba y no lo instale al revés.
▲ Tenga en cuenta que el nivel debe estar paralelo a la pared; de lo contrario, no se puede instalar la placa de cubierta.

◆ Control del Interruptor de Salida de Agua del Cuerpo Principal

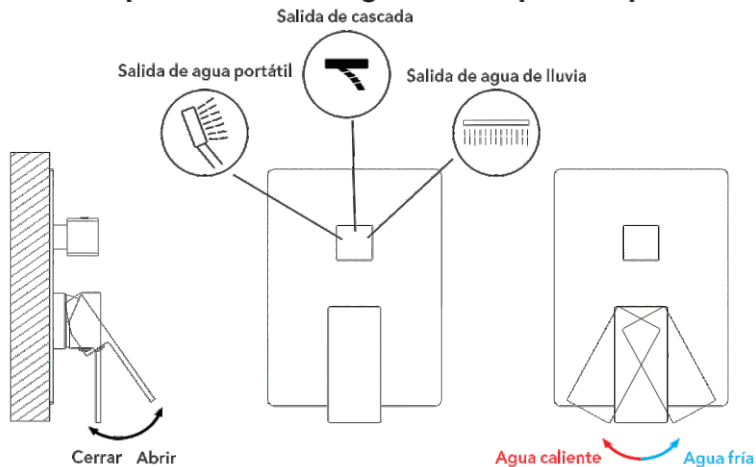

1. Abra la válvula de agua y verifique si hay alguna fuga.
2. Gire la manija hacia arriba para abrir la válvula de agua. El ángulo de giro puede controlar la tasa de flujo de agua. Luego, el usuario puede girarlo a la izquierda o a la derecha para controlar la temperatura del agua, donde la izquierda es para el agua caliente y la derecha para el agua fría.
3. La válvula de cambio puede alternar la salida de agua entre la cabeza de la ducha, la ducha superior y la ducha de mano.

◆ Instalación de la barra de elevación

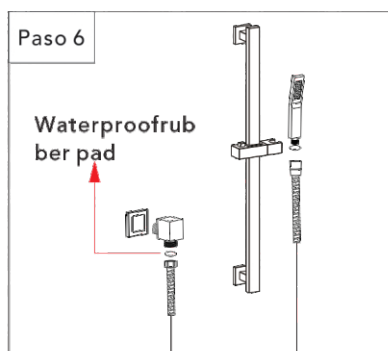
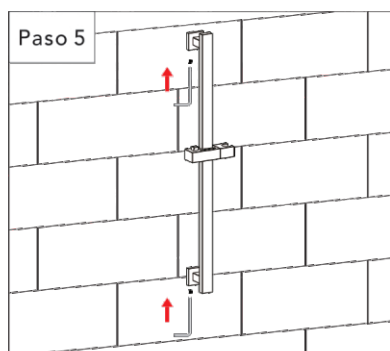
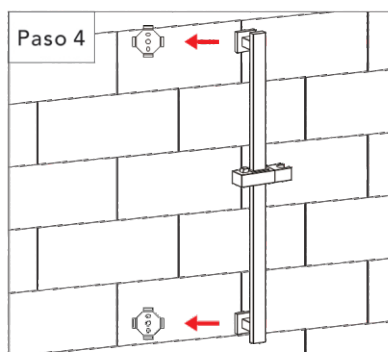
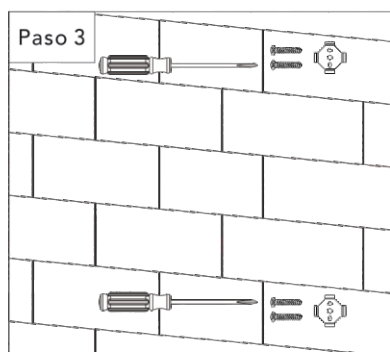
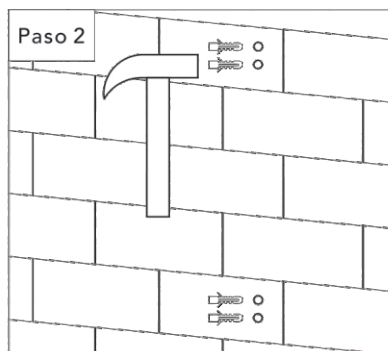
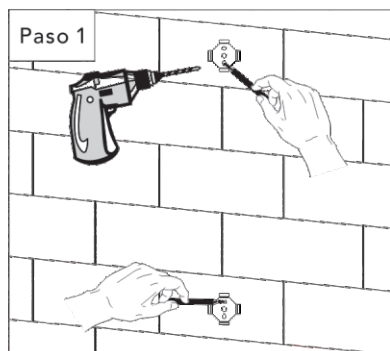

1. Marque la posición del golpe con un bolígrafo, perforaciones con un taladro eléctrico de 6 mm, golpe los granulos en finalmente, colocan la base y atornille los tornillos.
2. Ponga la rejilla del ascensor de la ducha en la base, luego apriete el tornillo, hecho.

Paso 1. El conector se envolverá con cinta de teflón, atornille la rosca en el agua tubería dentro de la pared.

Paso 2. Instale la almohadilla de goma en la manguera de ducha y conéctela con el conector

◆ Instalación del cabezal de ducha de 22 pulgadas

1. Excave la pared según el siguiente tamaño y conecte correctamente la entrada de lluvia y la de cascada.

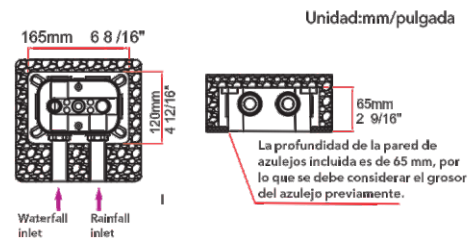

⚠ Si la caja empotrada está incrustada demasiado profunda, el cabezal de ducha no se instalará correctamente y causará problemas de fugas de agua y hundimiento. Preste atención a la profundidad de instalación.

2. Lock Inwall box refer to level meter guarantee horizontal level and test leaking for 24 hours.

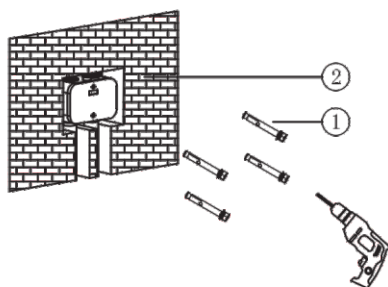

3. Mantenga la caja empotrada al mismo nivel que la pared después de sellar el azulejo y cubra el exceso de pared.

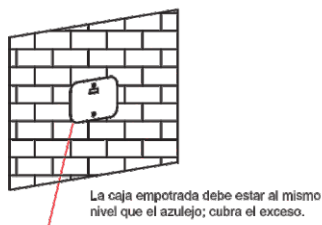

4. Instale el cuerpo del cabezal de la ducha. Primero retire la cubierta de la caja y el tapón, atornille las tres entradas de agua a la caja empotrada con la llave Allen S8. El papel más largo es el soporte.

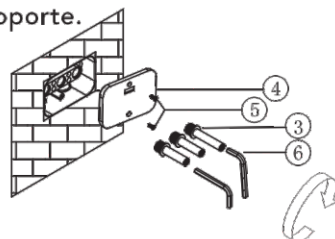

5. Instale la brida como se muestra en la imagen. Precaución: realice los pasos 4-5-6 para probar la posición horizontal y vertical del cabezal de la ducha antes de sellar la pared, para evitar problemas de reparación después del sellado de la pared.

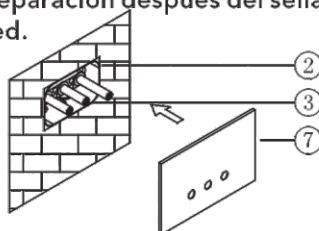

6. Empuje el cuerpo del cabezal de ducha hacia las entradas de agua correspondientes y apriete el cuerpo de la ducha con un tornillo M4 utilizando la llave Allen 2.5.

