

ASSEMBLY INSTRUCTIONS



ACCENT CHAIR

ASSEMBLY INSTRUCTIONS

ASSEMBLY TIPS:

- 1.Remove hardware from box and sort by size.
- 2.Please check to see that all hardware and parts are present prior to start of assembly.
- 3.Please follow attached instruction in the same sequence as numbered to assure fast & easy assembly.

WARNING!



- 1.Don't attempt to repair or modify parts that are broken or defective. Please contact the store immediately.
- 2.This product is for home use only and not intended for commercial establishment.

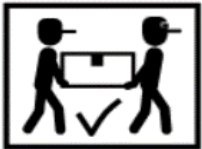

ASSEMBLY TIME PER UNIT:

15 MINUTES

PARTS IDENTIFICATION

A SEAT



1PC

C REAR LEG



2PCS

B FRONT LEG



2PCS

HARDWARE IDENTIFICATION

1. INNER HEXAGON SCREW
SIZE: M8*30MM



12PCS

3. SPRING WASHER
SIZE: M8



12PCS

2. FLAT WASHER
SIZE: Ø 8*18*2MM



12PCS

4. ALLEN WRENCH
SIZE: M5



1PC

ASSEMBLY INSTRUCTIONS
STEP 1

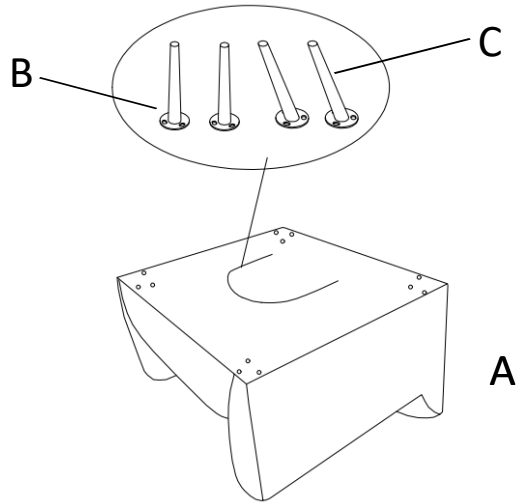

STEP 2

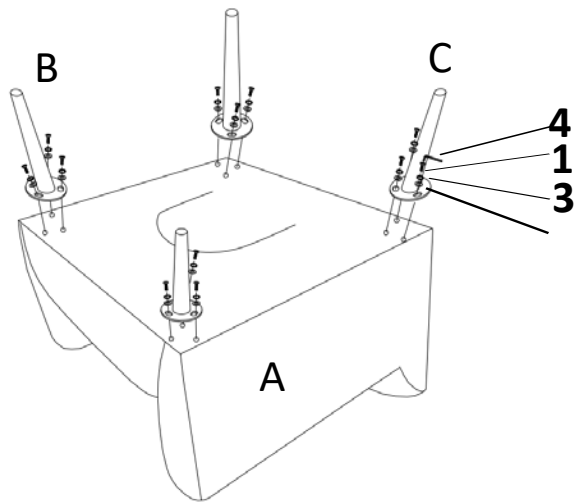

STEP 3

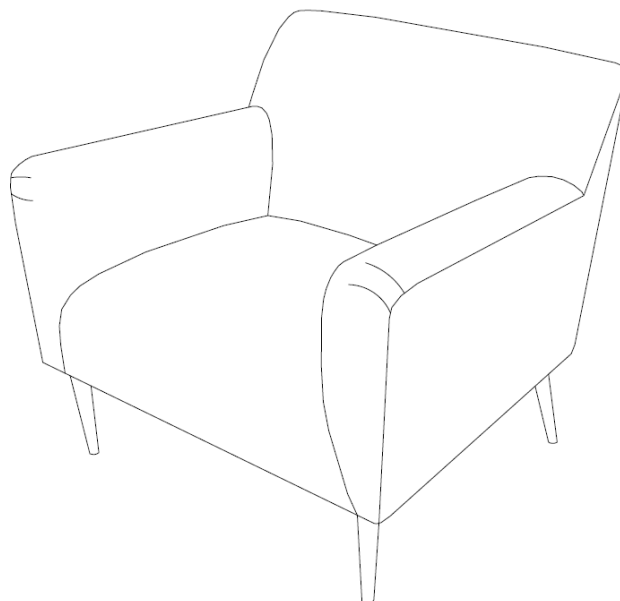

PRODUCT/PART DIMENSIONS

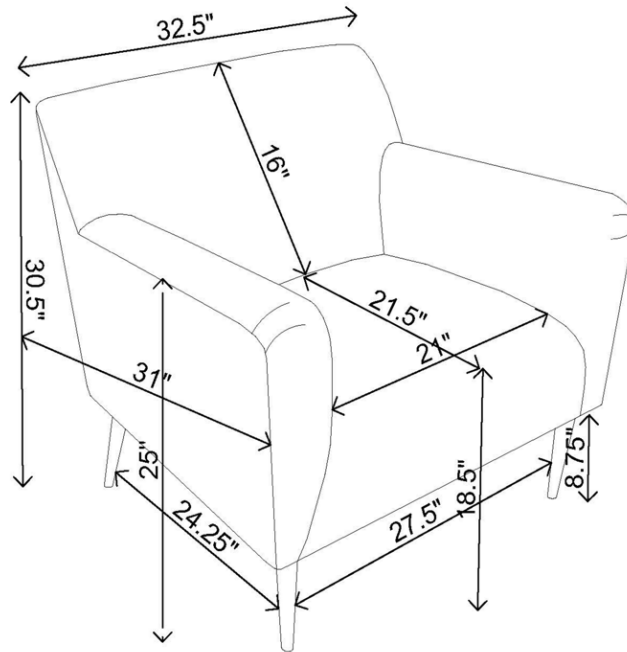

Note: Dimension tolerance $\pm 5\%$