

ASSEMBLY INSTRUCTION TV CABINET

Before you begin, please follow assembly instruction carefully.
Then follow them step by step.

STEP 1

(Insert Q-FIT as shown.)

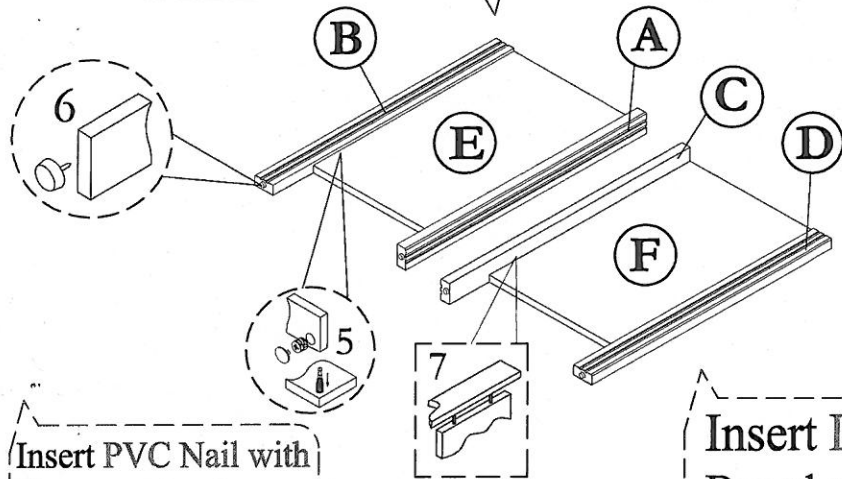

Insert PVC Nail with Pin to Board as shown.

Insert Dowel to Board as shown.

STEP 2

(Insert Q-FIT as shown.)

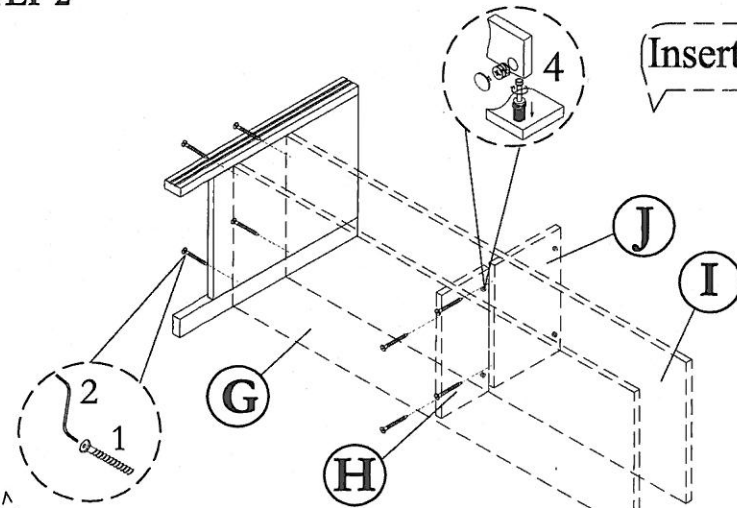

Insert JCBCW Screw to Board as shown.

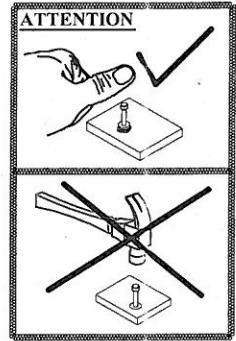

STEP 3

(Insert Q-FIT as shown.)

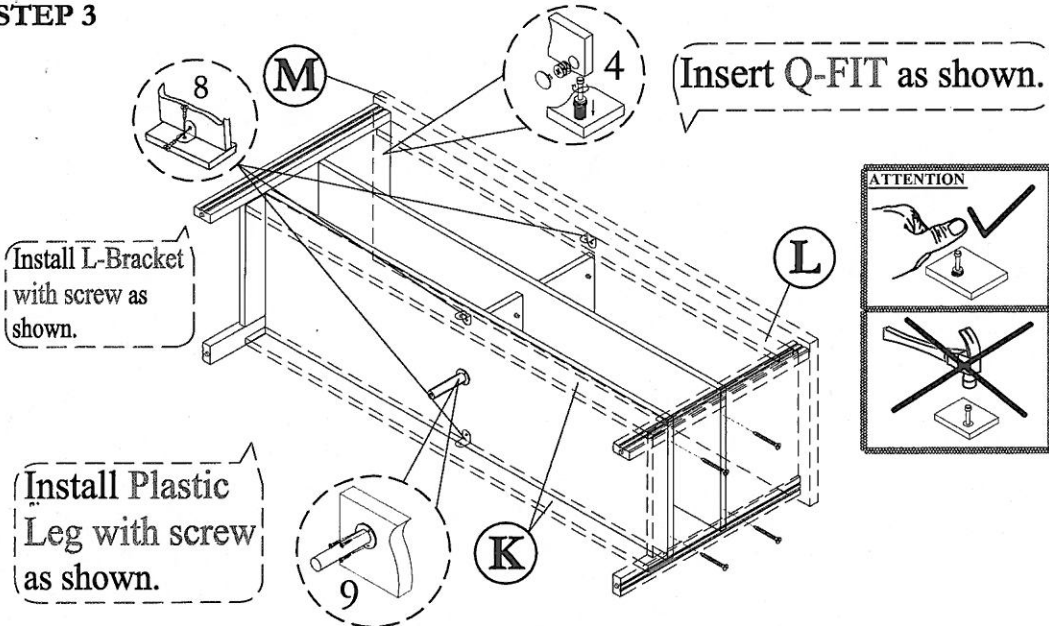

Install L-Bracket with screw as shown.

Install Plastic Leg with screw as shown.

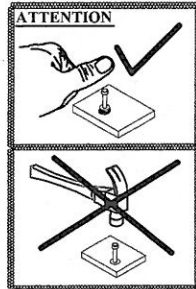

STEP 4

(Insert Dowel to Board as shown.)

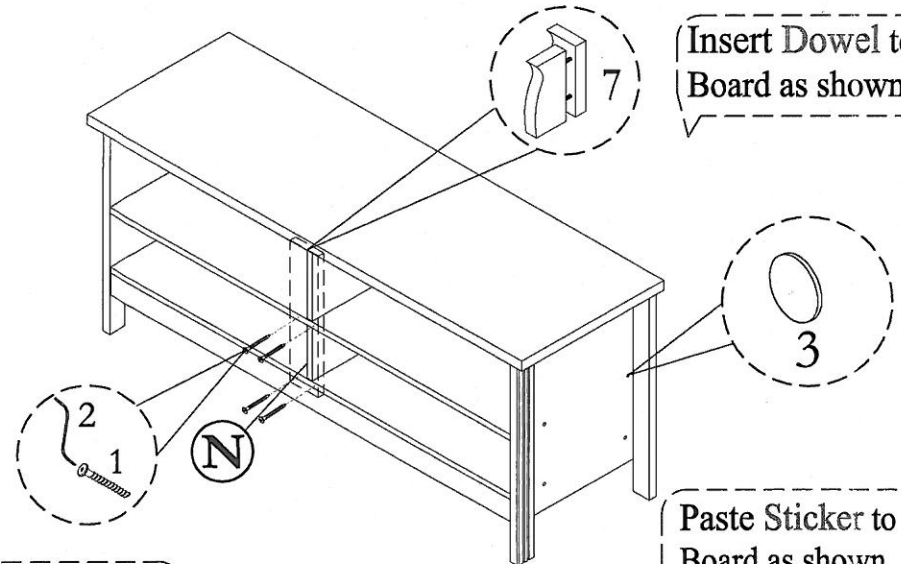

Insert JCBCW Screw to Board as shown.

Paste Sticker to Board as shown.

CAUTION:

To clean use soft, dry cloth. Do not use detergent or chemicals
 Avoid contact with water and direct sunlight.
 To be assembled on a soft, dry, clean and smooth surface.



ORDERING REPAIR PARTS

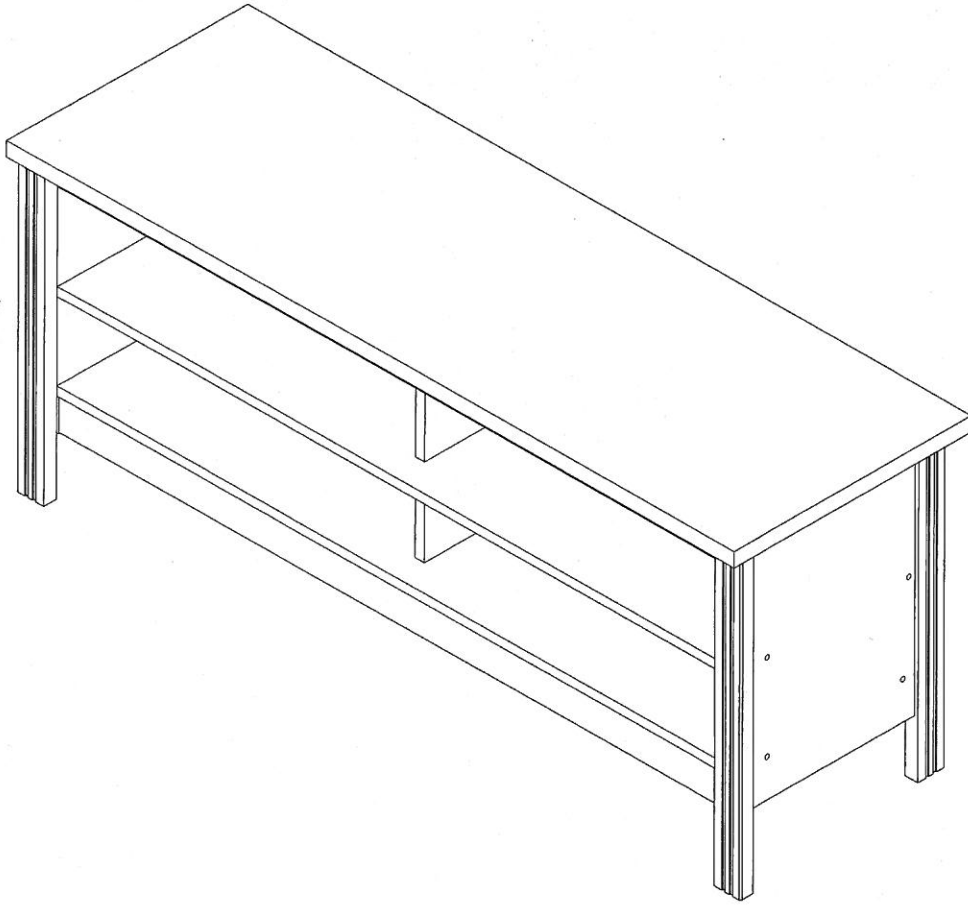
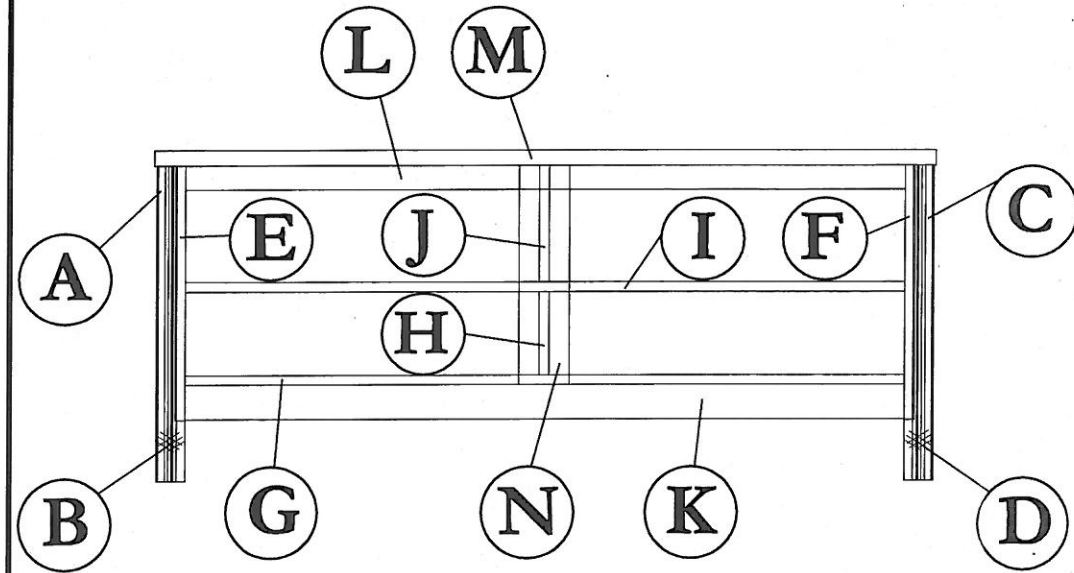



In order to obtain smooth and rapid service when ordering repair parts,
 please give full attention to the following of PART NUMBER.



**COMPLETE SET**

NO	DESCRIPTION	QTY
A	LEFT SIDE WRAPPING (Front)	01
B	LEFT SIDE WRAPPING (Back)	01
C	RIGHT SIDE WRAPPING (Front)	01
D	RIGHT SIDE WRAPPING (Back)	01
E	LEFT SIDE	01
F	RIGHT SIDE	01
G	LOWER SHELF	01

NO	DESCRIPTION	QTY
H	CENTRE VERTICAL	01
I	CENTRE SHELF	01
J	CENTRE VERTICAL	01
K	LOWER SHELF SUPPORT	02
L	TOP SUPPORT	01
M	TOP	01
N	BACK	01

HARDWARE LIST			
NO	DESCRIPTION		QTY
1	JCBCW SCREW M6.3 x 50		16pcs
2	M4 ALLEN KEY		1pc

3	STICKER		8pcs
4	Q-FIT		8sets
5	Q-FIT (small)		8sets
6	PVC NAIL WITH PIN		5pcs

7	M8 x 30 WOOD DOWEL		16pcs
8	L BRACKET & SCREW M3.5 x 12		3sets
9	PLASTIC LEG & SCREW M3.5 x 16		1sets