

PAETA

Solira SN00 Sauna Room Installation Manual

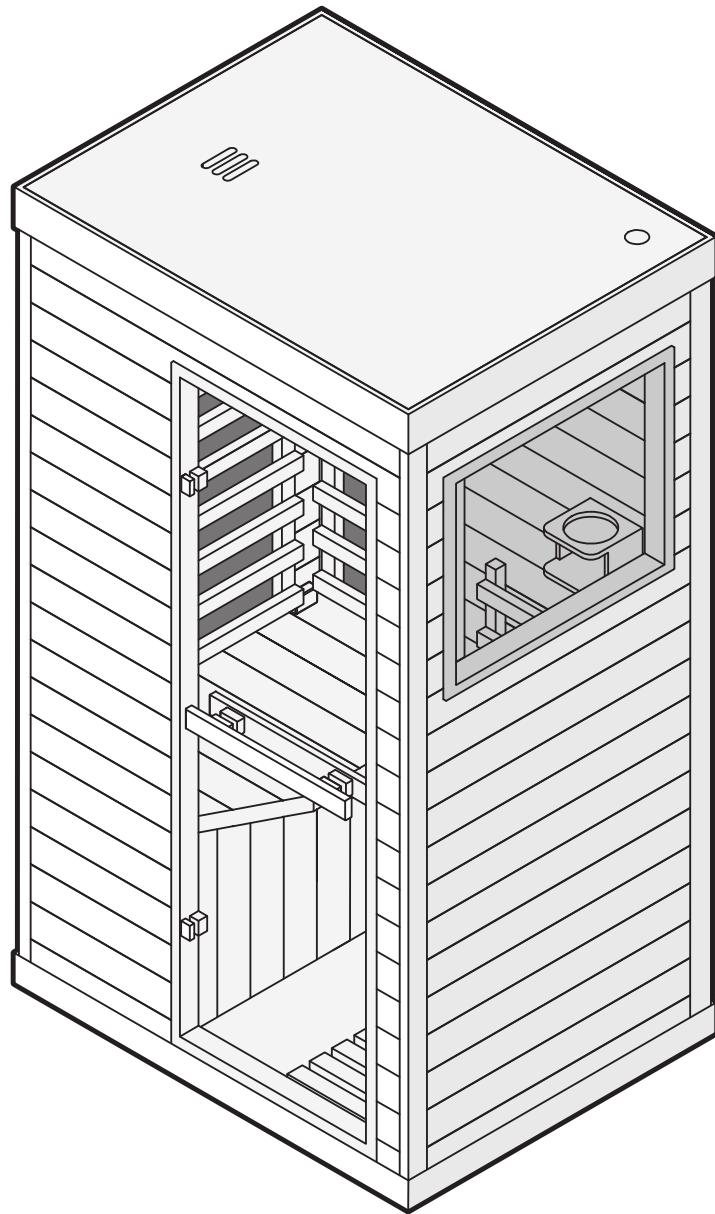

Note: Please read manual before construction

After-sales service email: PAETA_STORE@outlook.com

IMPORTANT SAFETY GUIDE

PLEASE STRICTLY FOLLOW SAFETY PRECAUTIONS WHEN USING!

- (01) **DO NOT INSERT** fingers, hands, or any objects into the heating elements or under the heating base, this can cause serious injury or equipment damage.
- (02) **NEVER** pour water on the equipment or heating panels. This may result in electrical shock or damage.
- (03) **DO NOT** use or store flammable materials (e.g, hairspray, oil paint, gasoline) near the sauna.
- (04) **DO NOT** place items on top of or inside the sauna unless specified by the manufacturer.
- (05) **DO NOT TOUCH** the control panel or electrical components with wet hands to avoid electric shock.
- (06) **DO NOT** strike or puncture the sauna with sharp objects.
- (07) **SHUT DOWN** the sauna and allow it to rest for at least 1 hour after 1.5hours of continuous use.
- (08) **CHILDREN** are not intended to use this product.
- (09) **DO NOT OPERATE** the sauna if you have consumed alcohol.
- (10) Individuals with bleeding disorders or hemophilia should avoid sauna use unless cleared by a medical professional.
- (11) **CONSULT YOUR DOCTOR** before use if you are pregnant, on medication, or have any medical conditions.
- (12) **DO NOT USE** the sauna immediately after intense exercise. Allow your body temperature to normalize first.
- (13) If you feel dizzy, lightheaded, or uncomfortable, **STOP USE IMMEDIATELY.**
- (14) **MIND YOUR HEAD** when entering or exiting the sauna to avoid injury.
- (15) **DO NOT SLEEP** inside the sauna while it is operating.
- (16) **WEAR** eye protection when using the red light therapy.
- (17) **AVOID CONTACT** with the heating elements to prevent burns.
- (18) **KEEP THE SEAT AREA DRY** To maintain product integrity.
- (19) **KEEP THE FLOOR DRY** to reduce sweat buildup and slip risk.
- (20) **NEVER COVER** the heating panels or infrared emitters. Doing so can cause fire.
- (21) **INDOOR USE ONLY** -This sauna is not designed for outdoor use.use only in dry, well-ventilated indoor spaces away from moisture or water sources.
- (22) **ENSURE PROPER VENTILATION** around the sauna and electrical outlet. Avoid placing it against curtains, walls, or any flammable surfaces.
- (23) **INSPECT REGULARLY**- Check power cords and heating panels for signs of wear or damage before each use.
- (24) **UNPLUG WHEN NOT IN USE** To prevent potential electrical issues or power surges.
- (25) **DO NOT MODIFY** or disassemble the sauna unless directed by a certified technician.

IMPORTANT SAFETY INSTRUCTIONS

+DANGERS/WARNINGS

CONSULT A DOCTOR BEFORE USE, THIS IS NOT A MEDICAL DEVICE. IF YOU HAVE ANY OF THE CONDITIONS BELOW, USE OF THE SAUNA IS NOT RECOMMENDED WITHOUT YOUR DOCTOR'S APPROVAL:

- You have skin diseases, burns, or reddening.

- You have splanchnic diseases.

- You require a heart defibrillator or use any other implantable devices.

- You have heart disease or an illness.

- You have broken bones.

- You have a malignancy.

- You feel nauseous, have a headache, or other symptoms.

- You have just had surgery.

- You have osteoporosis.

- You suffer from abnormal blood pressure.

- You are currently pregnant or breastfeeding

- You have anhidrosis.

- You have cancer or other malignant conditions.



- You have any metal or other body implants, including breast implants.

- You have a mental illness.

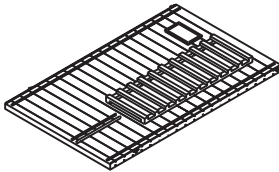
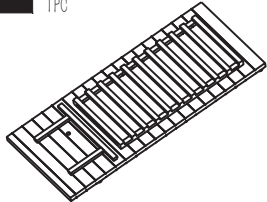
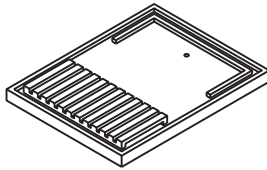
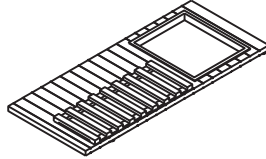
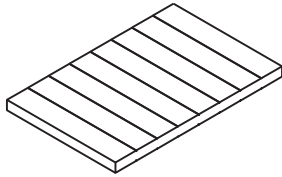
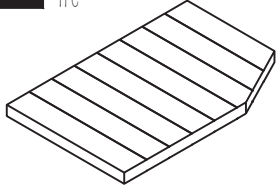
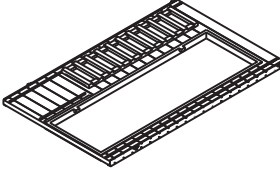
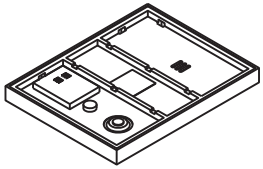
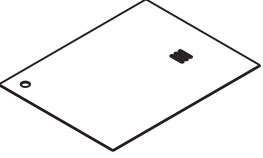
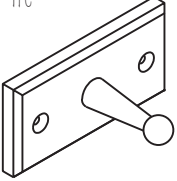
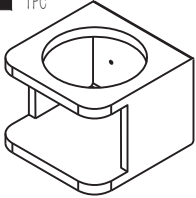
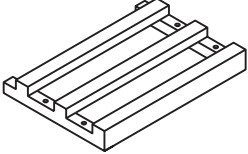
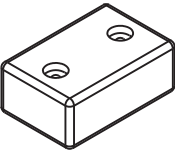
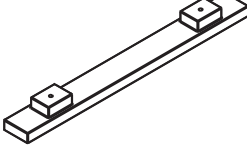
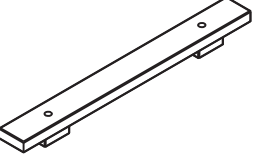
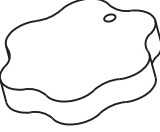
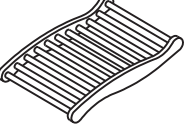
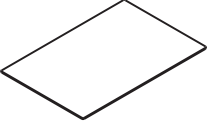
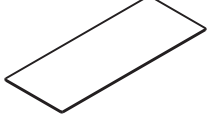
PARTS LIST

<p>A1 Back Panel 1PC</p> 	<p>A2 Right Panel 1PC</p> 	<p>A3 Sauna Base 1PC</p> 	<p>B1 Left Panel 1PC</p> 	<p>C1 Seat Support Panel 1PC</p> 
<p>D1 Seat Panel 1PC</p> 	<p>E1 Front Panel 1PC</p> 	<p>F1 Roof Panel 1PC</p> 	<p>G1 Roof Cover Panel 1PC</p> 	<p>H1 Aroma Stone Hook 1PC</p> 
<p>H2 Cup Holder 1PC</p> 	<p>H3 Magazine Rack 1PC</p> 	<p>I1 Support Block 2PCS</p> 	<p>J1 Outer Door Handle 1PC</p> 	<p>J2 Inner Door Handle 1PC</p> 
<p>K1 Aroma Stone 1PC</p> 	<p>K2 Sauna Backrest 1PC</p> 	<p>K3 Sauna Floor Mat (External) 1PC</p> 	<p>K4 Sauna Floor Towel (Internal) 1PC</p> 	

HARDWARE LIST

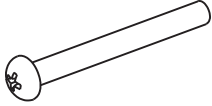
<p>1 Bolt(M4 × 25) 14PCS</p> 	<p>2 Bolt(M4 × 35) 4PCS</p> 	<p>3 Bolt(M5 × 60) 2PCS</p> 		
---	--	--	--	--

EASY INSTALLATION STEPS

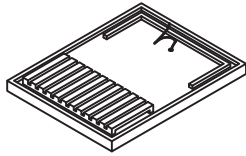

Sauna Base

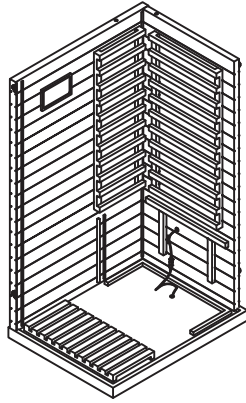

Back/Right Side

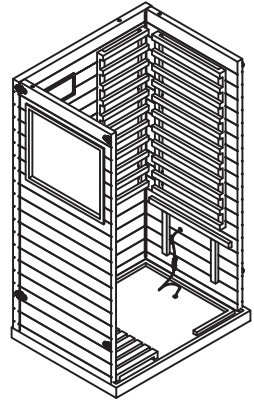

Left Side Panel

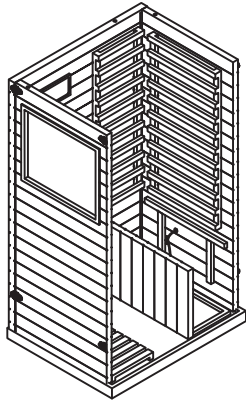

Seat Support

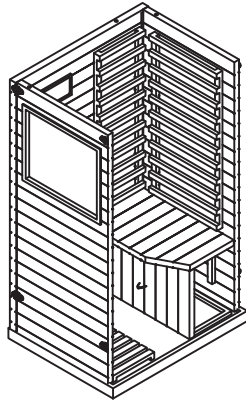

Seat Board

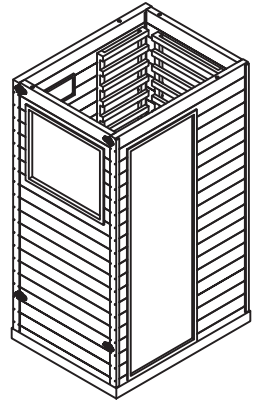

Front Panel

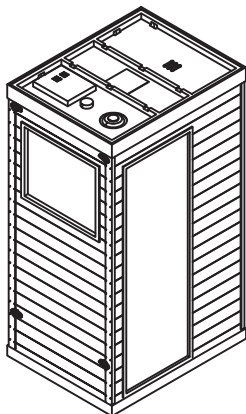

Control Panel

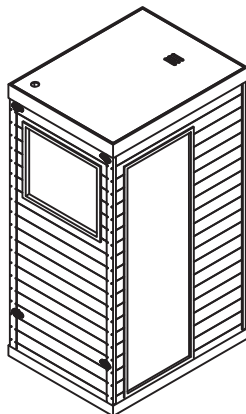

Roof Panel

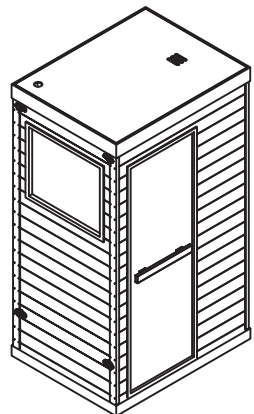

Door Handle

STEP 1:

A1 Back Panel
1PC

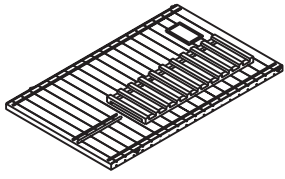

A2 Right Panel
1PC

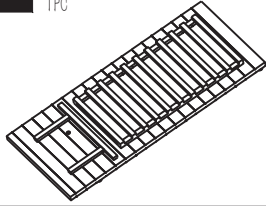

A3 Sauna Base
1PC

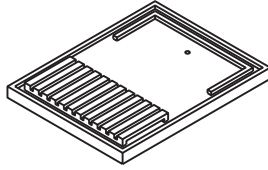

Lock Into Place

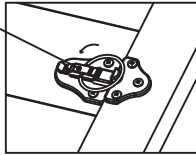

Press Firmly

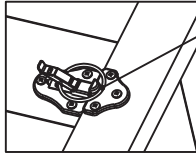

Snap into the slot

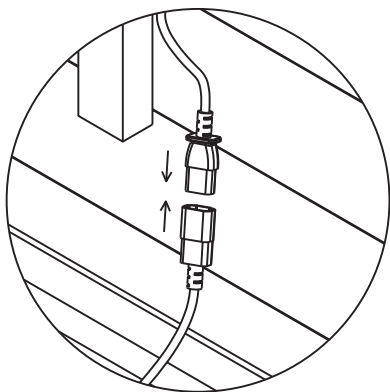
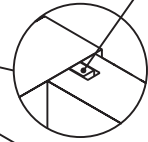

A1

A2

A3

STEP 2.

B1 Left Panel
IPC

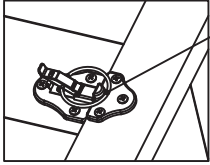
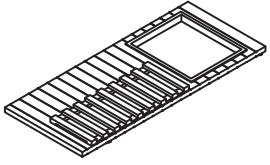

Press Firmly

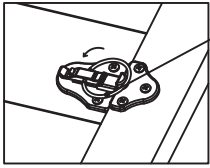

Lock Into Place

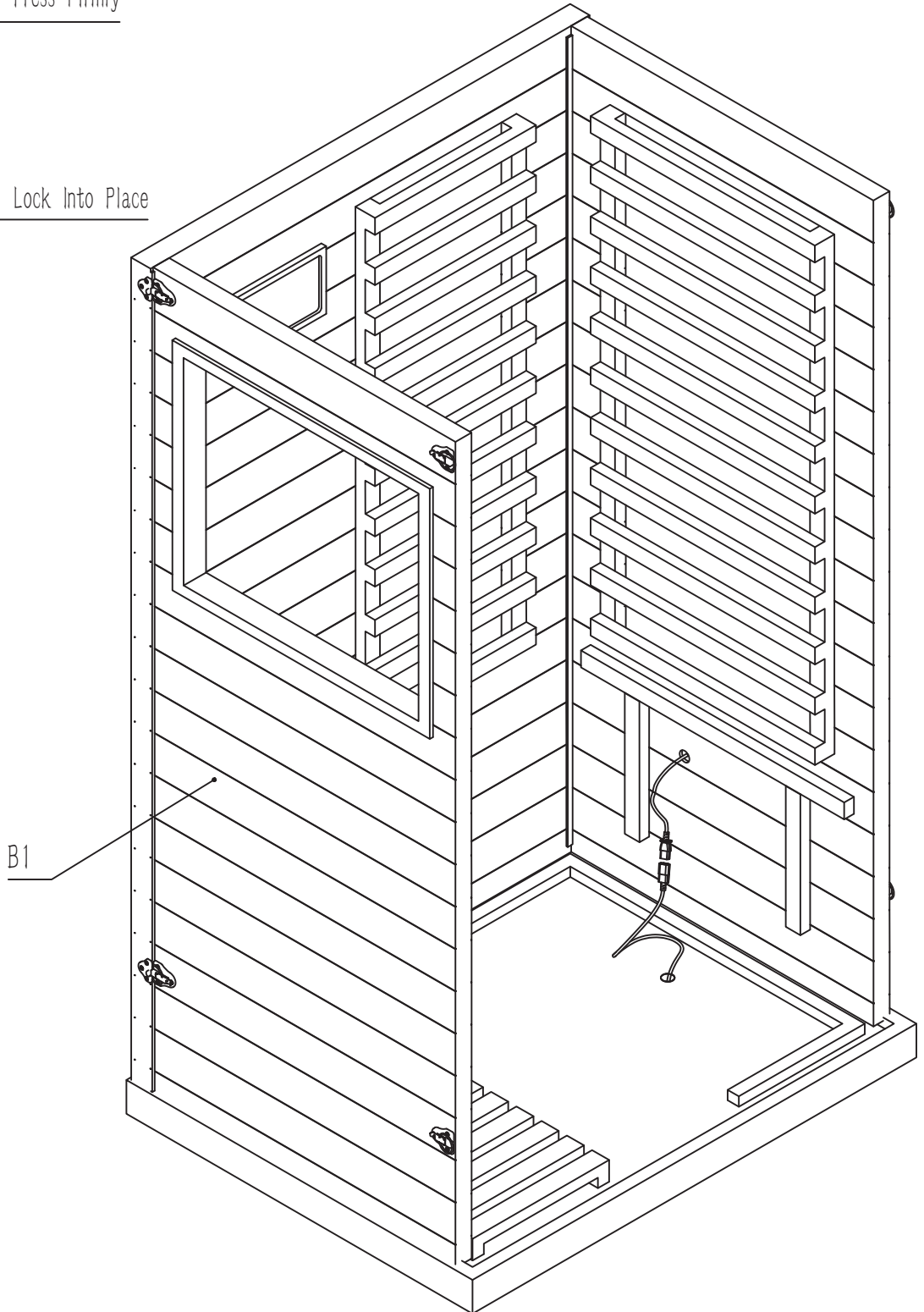

B1

STEP 3.

C1 Seat Support Panel
1PC

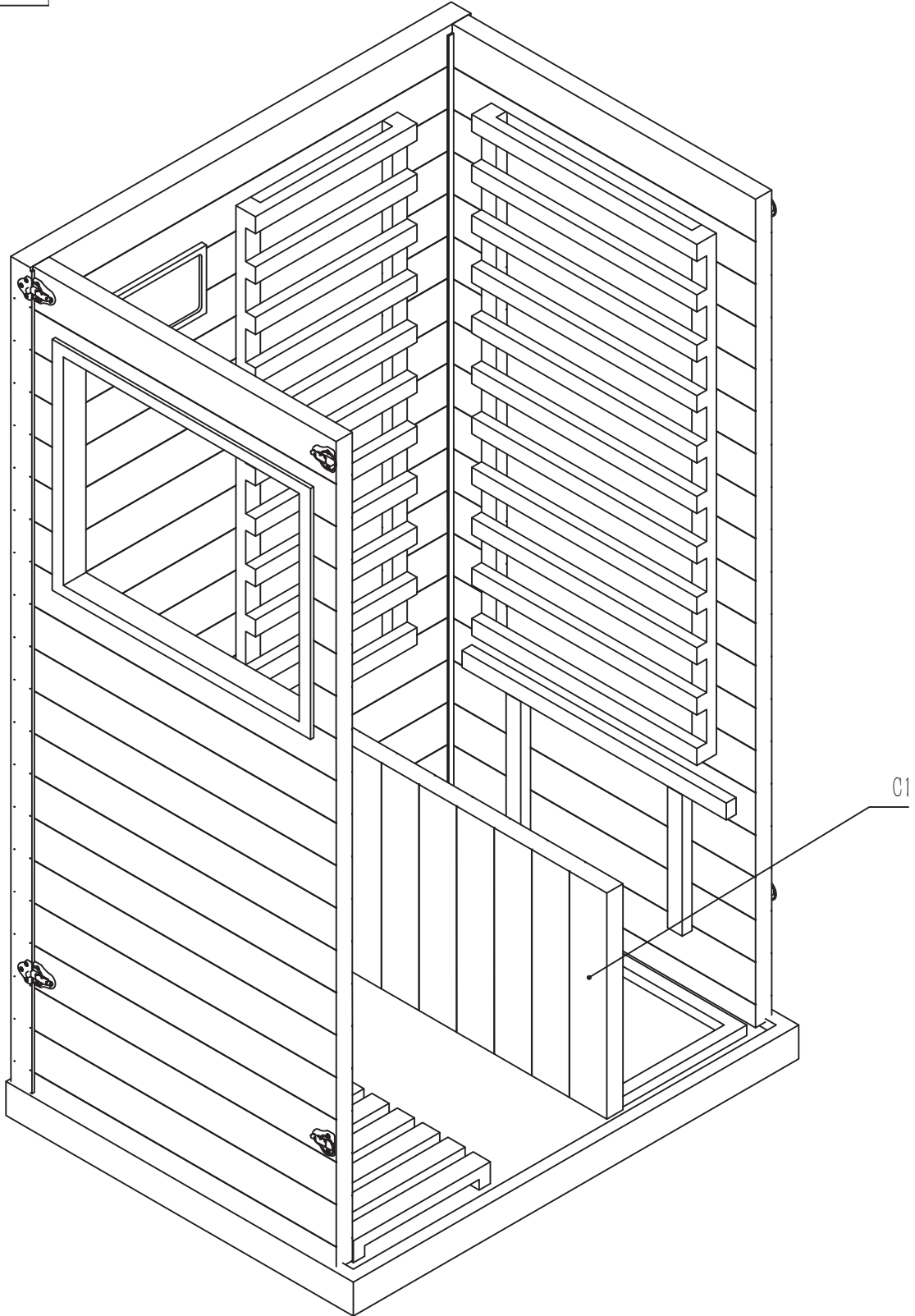
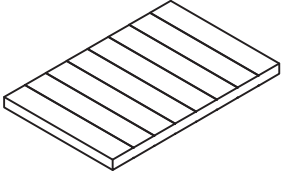

STEP 4.

D1 Seat Panel
IPC

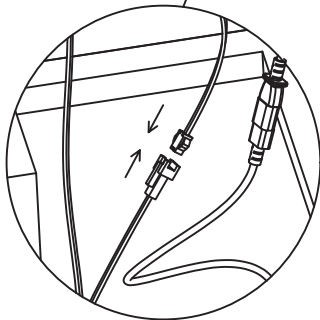
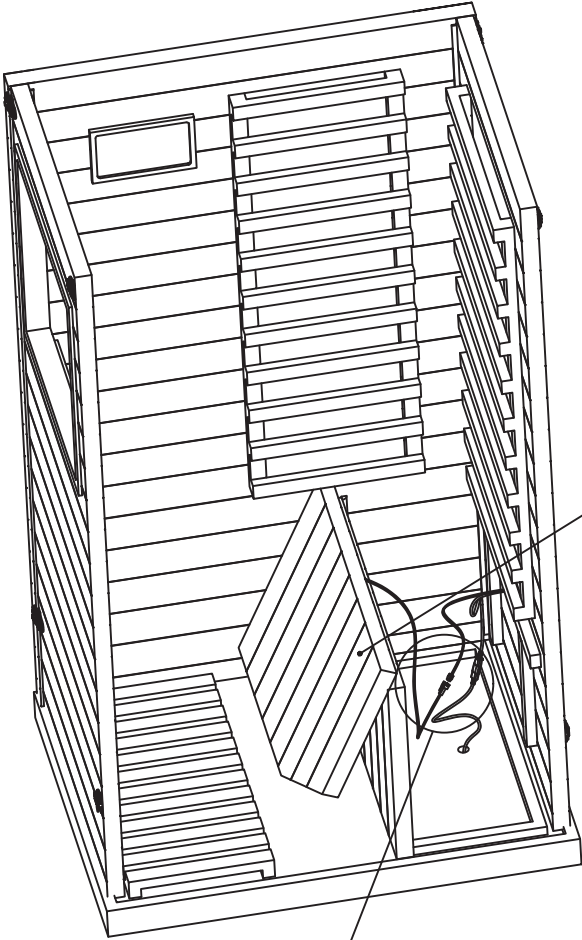
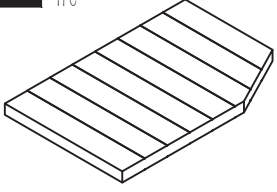

D1

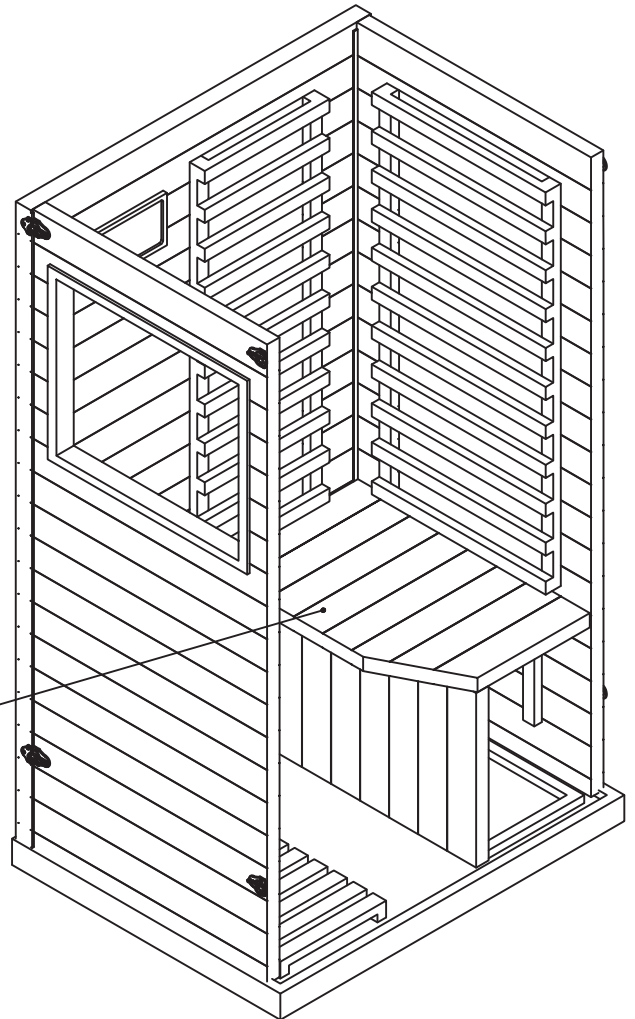

D1

STEP 5.

E1 Front Panel
1PC

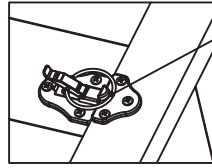
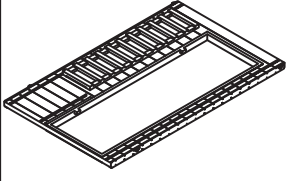

Press Firmly

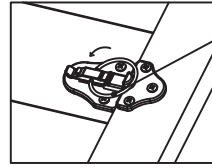

Lock Into Place

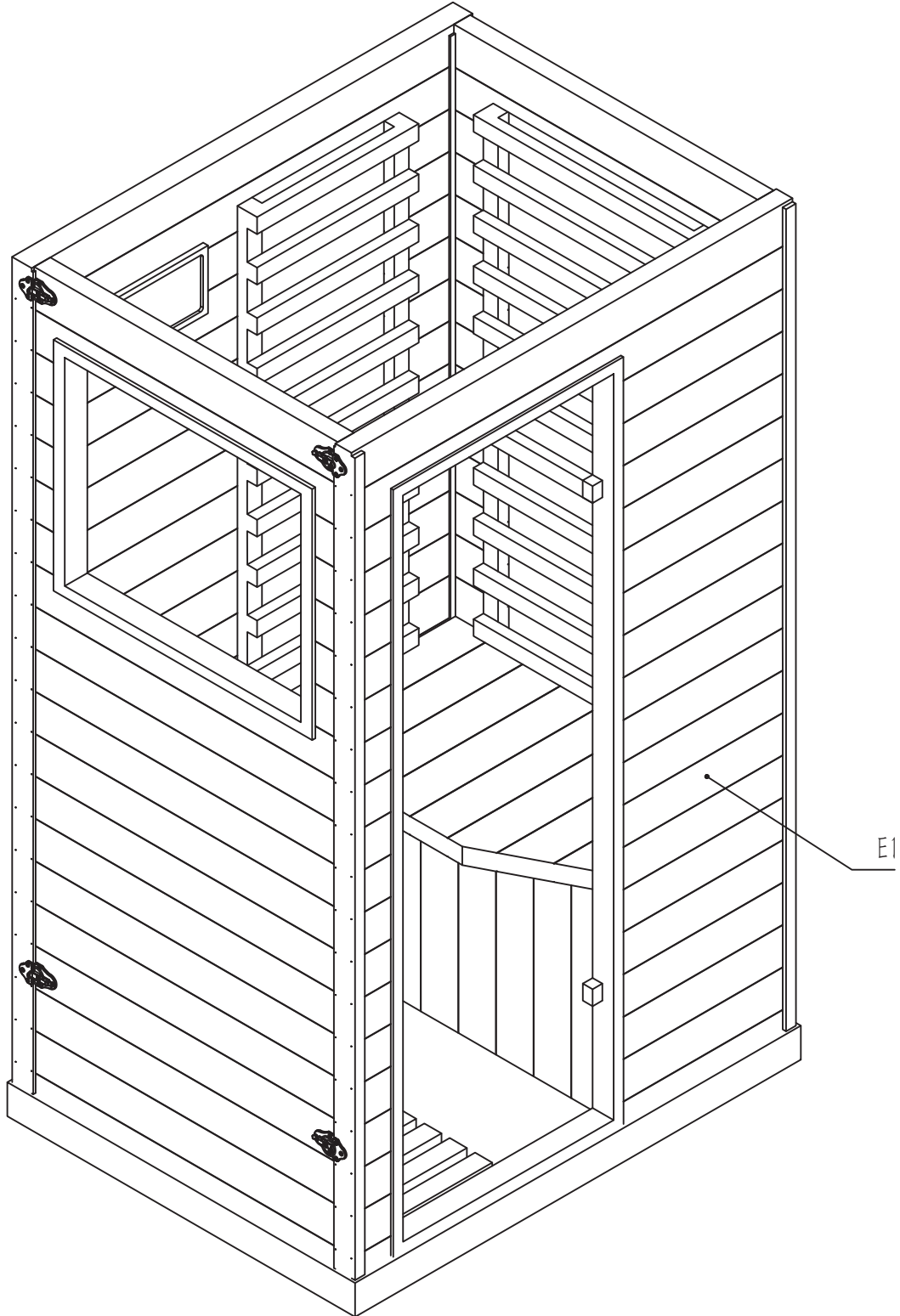

STEP 6.

F1 Roof Panel
IPC

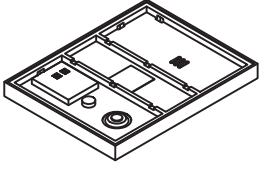

Pass the wiring on top of each panel through the corresponding holes in the roof panel (#F1).

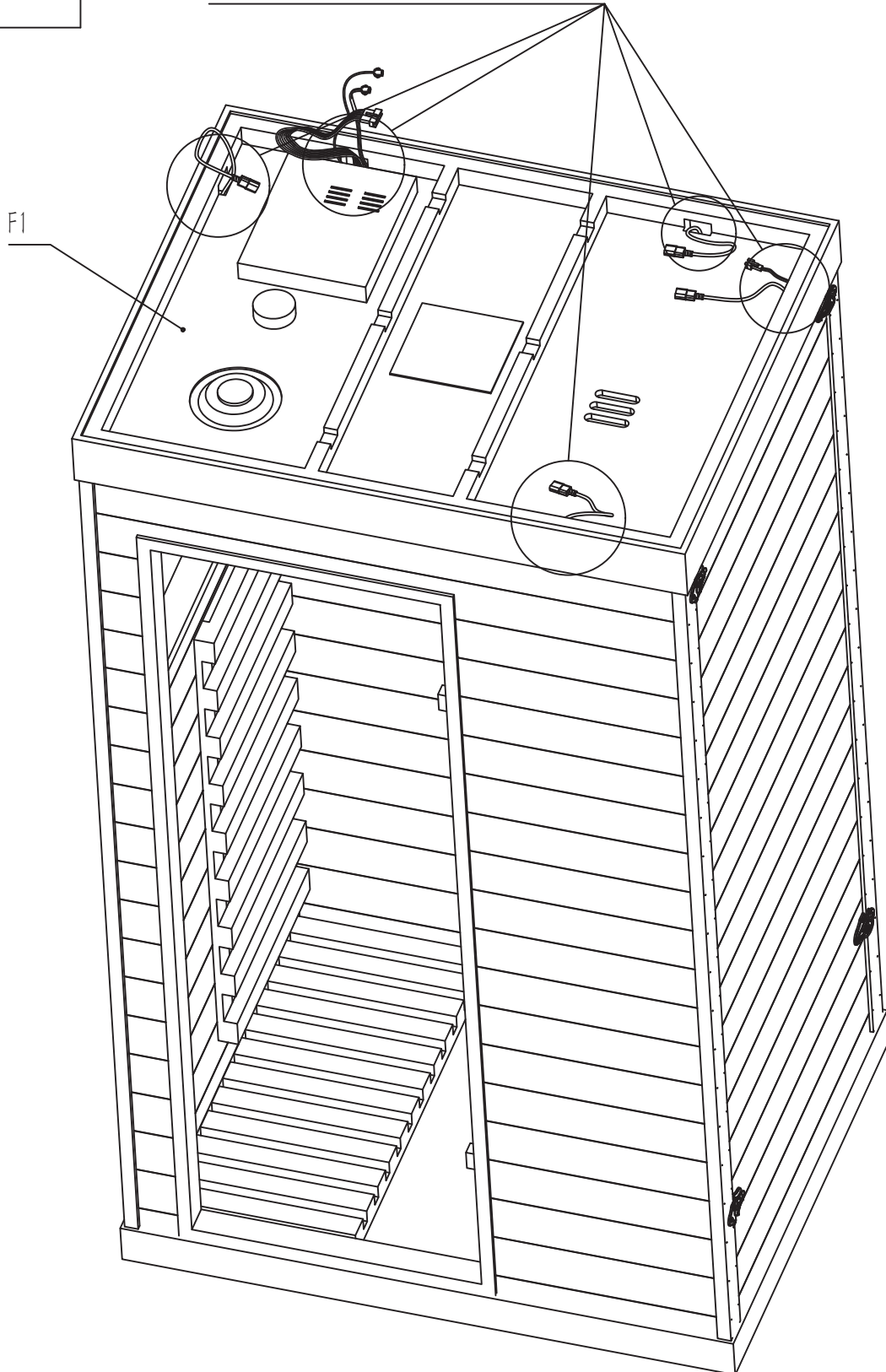

STEP 7:

Color correspondence

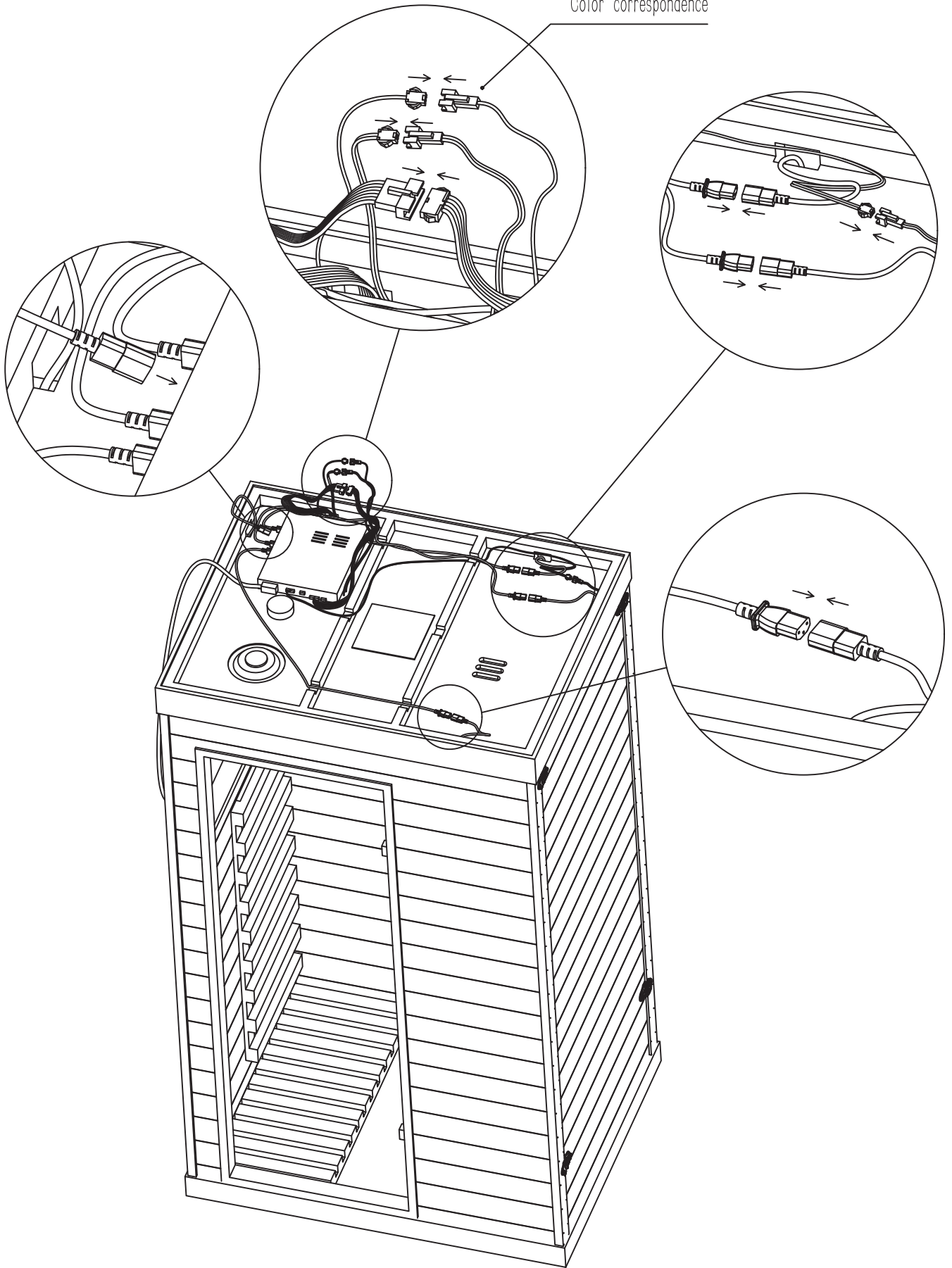

STEP 8.

G1 Roof Cover Panel
1PC

1 Bolt(M4 x 25)
8PCS

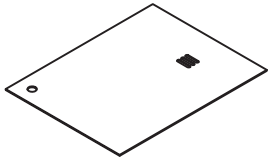

Pass the power cord through this hole.

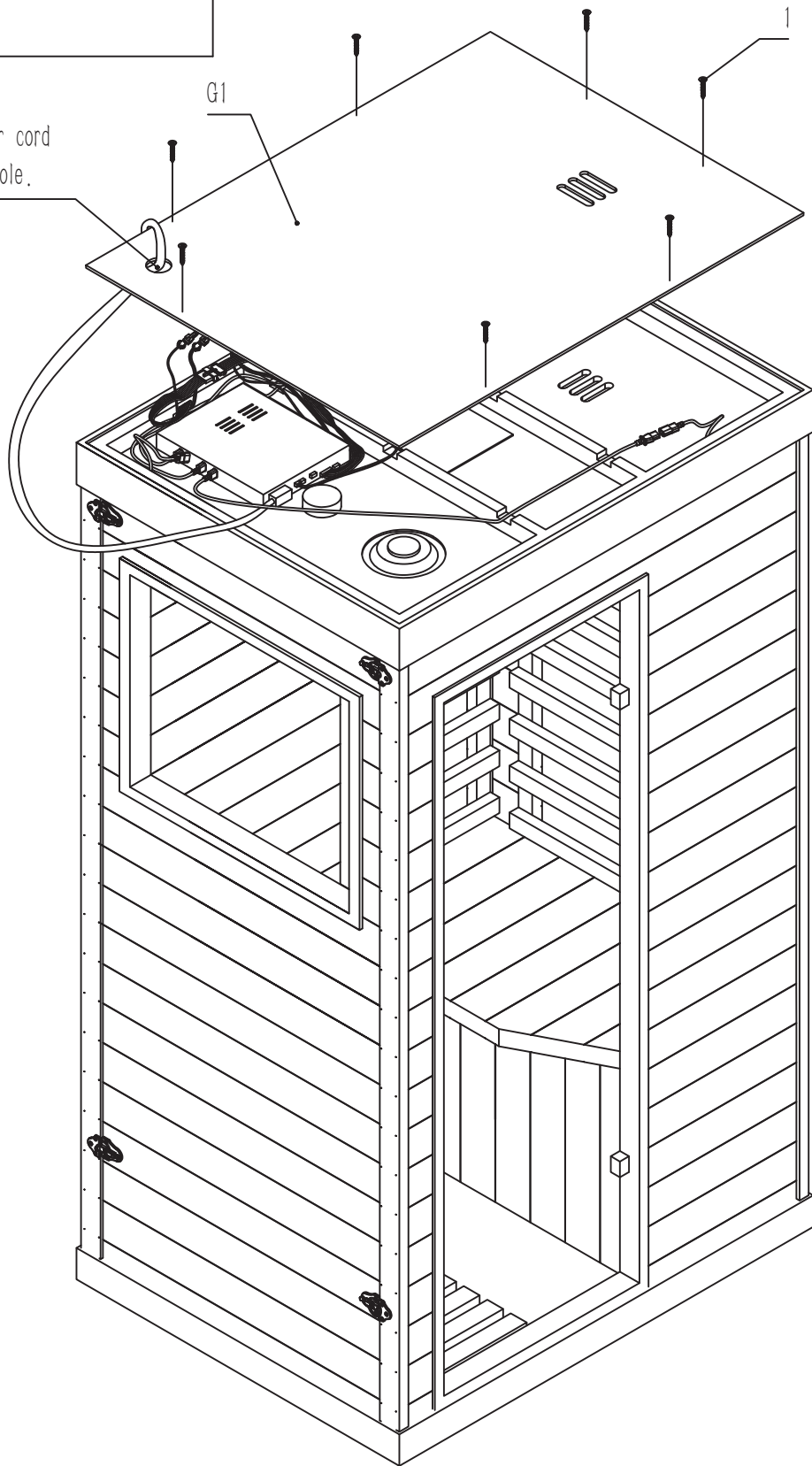

STEP 9.

H1 Aroma Stone Hook
1PC

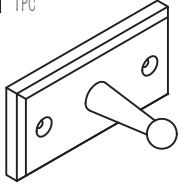

H2 Cup Holder
1PC

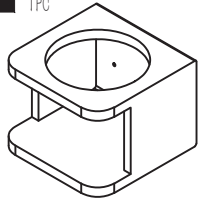

H3 Magazine Rack
1PC

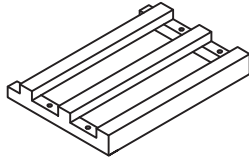

1 Bolt(M4 x 25)
6PCS



H1, H2, and H3 can be installed in different positions as needed.

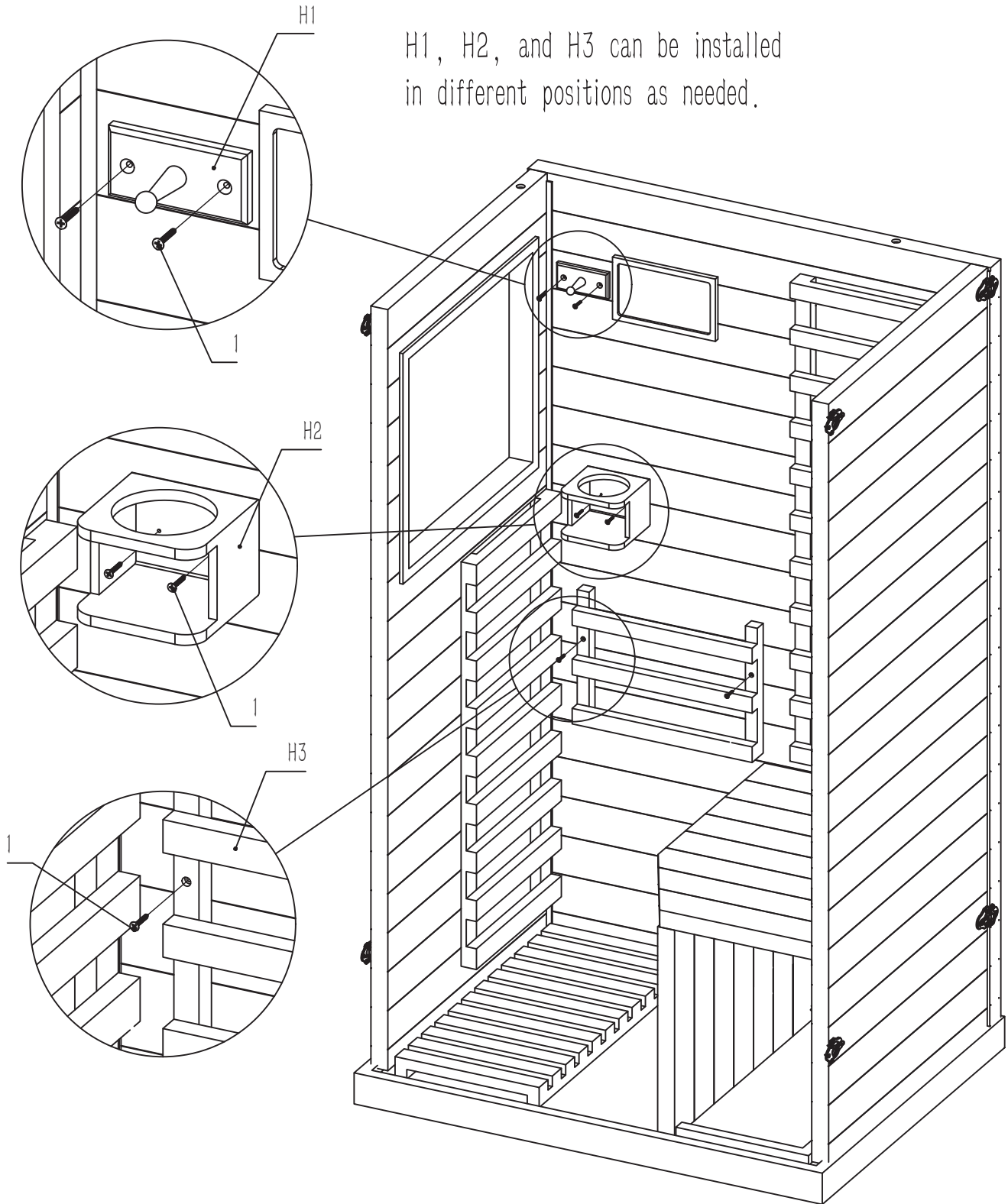

STEP 10:

I1 Support Block
2PCS

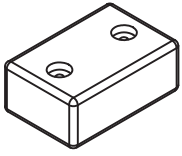

2 Bolt(M4 x 35)
4PCS

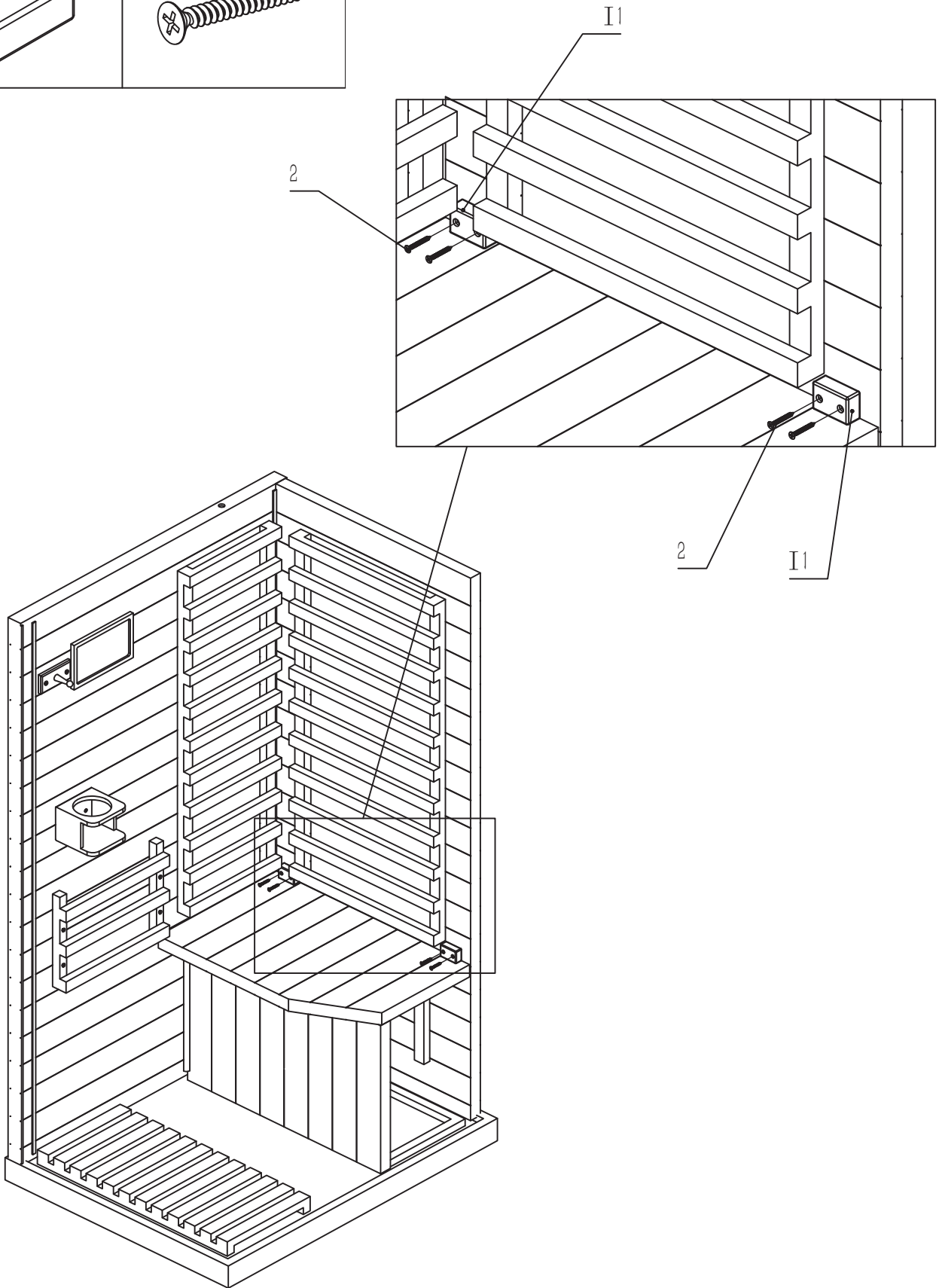
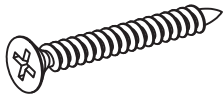

STEP 11:

J1 Outer Door Handle
1PC

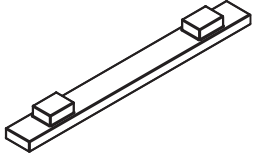

J2 Inner Door Handle
1PC

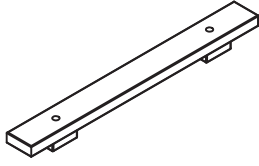

3 Bolt(M5 x 60)
2PCS

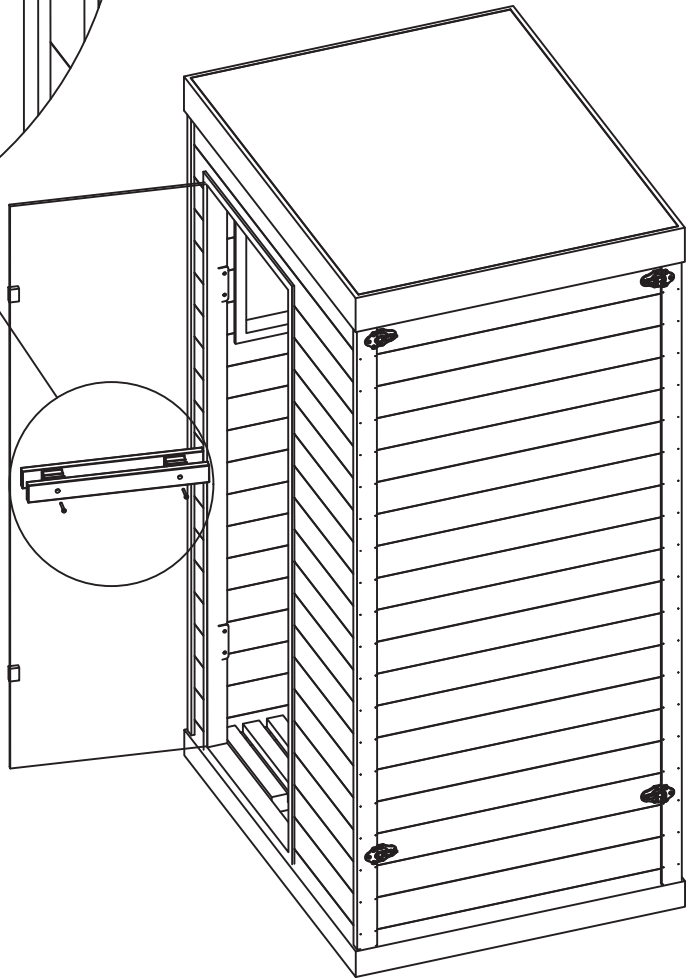
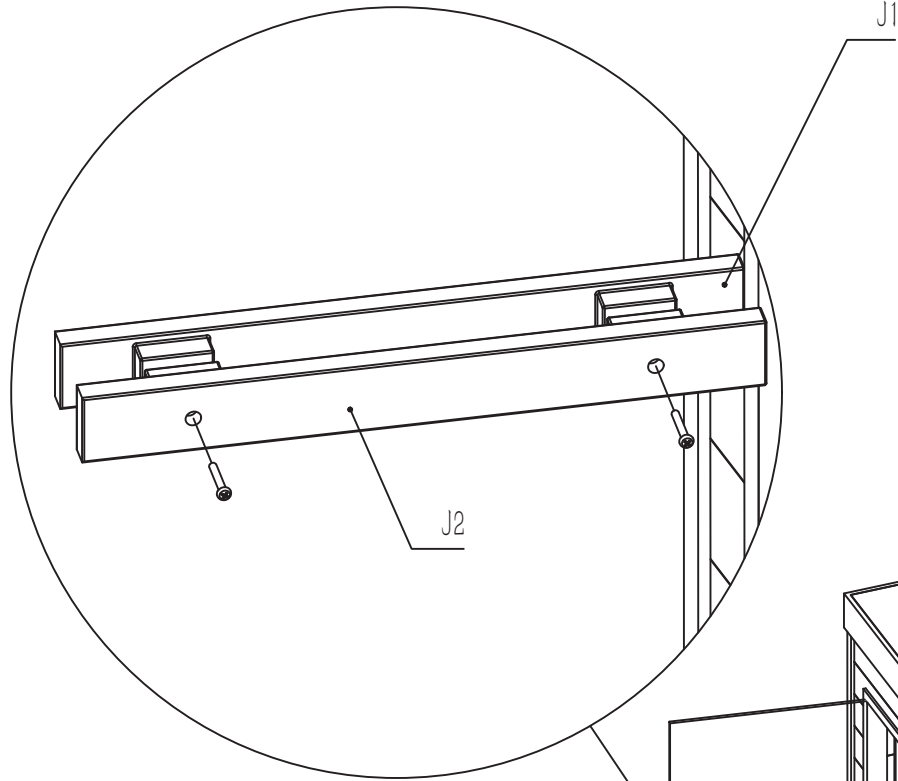
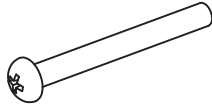

OPERATION

PRECAUTIONS

- (01) Check that all the circuitry and the plug meet all requirements.
- (02) Set the temperature and time to a comfortable level.
- (03) Drink water before the sauna session.
- (04) After 1.5 hours of continuous use, shut the sauna down for one hour
- (05) To avoid burns, do not touch the heating elements or red light
- (06) WARNING: Covering the heater or infrared emitter causes fire risk!

OPERATION

- (01) Plug the sauna into an outlet that is stated in the nameplate. Do not share the outlet with any other appliances. The sauna should be unplugged when not in use.
- (02) After your sauna session, turn off and unplug the power cable
- (03) DO NOT OPERATE THE SAUNA UNSUPERVISED TO REDUCE THE RISK OF FIRE

NOTE: WHEN THE ENVIRONMENTAL TEMPERATURE IS LOW, THE HEATING TIME WILL TAKE LONGER. IT IS ALSO POSSIBLE THE SAUNA TEMPERATURE DISPLAY IS NOT ABLE TO REACH ITS MAXIMUM TEMPERATURE. THIS IS NORMAL AND DOES NOT IN ANY WAY AFFECT THE PERFORMANCE OF THE INFRARED HEATERS OR THEIR HEALTH. THE SAUNA TEMPERATURE SENSOR ONLY MEASURES THE HEAT RADIATED BY THE HEATING ELEMENTS. IT DOES NOT MEASURE THE INFRARED HEATERS PENETRATING HEAT, AND THIS IS WHERE MOST OF THE HEALTH BENEFITS ARE.

MAINTENANCE

BEFORE USING

- (01) Please be sure to follow the instruction manual before operations.
- (02) Prepare a towel on the seat bench to prevent sweat from dripping onto it. To avoid affecting the quality of the wood

AFTER USING

- (01) Please unplug the power plug.
- (02) Open the door to let the heat and humid water vapor dissipate and keep the sauna cabin dry

STAIN ON WOOD

- (01) The outer cabin can be wiped with a wrung wet towel. The inner cabin can be wiped by small vacuum cleaner.
- (02) Do not use organic solvents to decontaminate, such as gasoline, alcohol, etc. Wipe the sauna surface,
- (03) Do not use sharp objects in sauna cabin to prevent scratching woods.

STAIN ON GLASS

- (01) Wipe the glass with soft paper
- (02) Stubborn stains can be wiped with a damp cloth, then dried with a dry cloth
- (03) Do not scratch the surface with a sharp object to prevent scratching the glass.

TRANSPORTATION AND STORAGE

- (01) Avoid water, snow, and intense impact during the transportation

- (02) Do not store it in a humid environment
- (03) In dry climates, wipe the product frequently with a well-wrung damp towel.
- (04) In humid climates, air-dry the product regularly.

WARRANTY & SUPPORT

This product comes with a 1-year limited warranty covering manufacturing defects. If you experience issues, please contact us at **PAETA_STORE@outlook.com**

WARRANTY INFORMATION

If a covered component is found to have a manufacturing defect or technical malfunction, we will either repair or replace the affected part, at our discretion of charge.

Limitations: Please note that our warranty does not cover damages resulting from normal wear and tear, misuse, accidental damage, alterations, unauthorized repairs, or any damages caused by factors beyond our control . Our warranty is non-transferable and applies only to the original purchaser of the **Solira**.

DISCLAIMER: Solira SHALL NOT BE HELD LIABLE FOR ANY INDIRECT INCIDENTAL, OR CONSEQUENTIAL DAMAGES ARISING FROM THE USE OR INABILITY TO USE THE Solira, EVEN IF ADVISED OF THE POSSIBILITY OF SUCH DAMAGES.

Sauna Control Panel Instructions

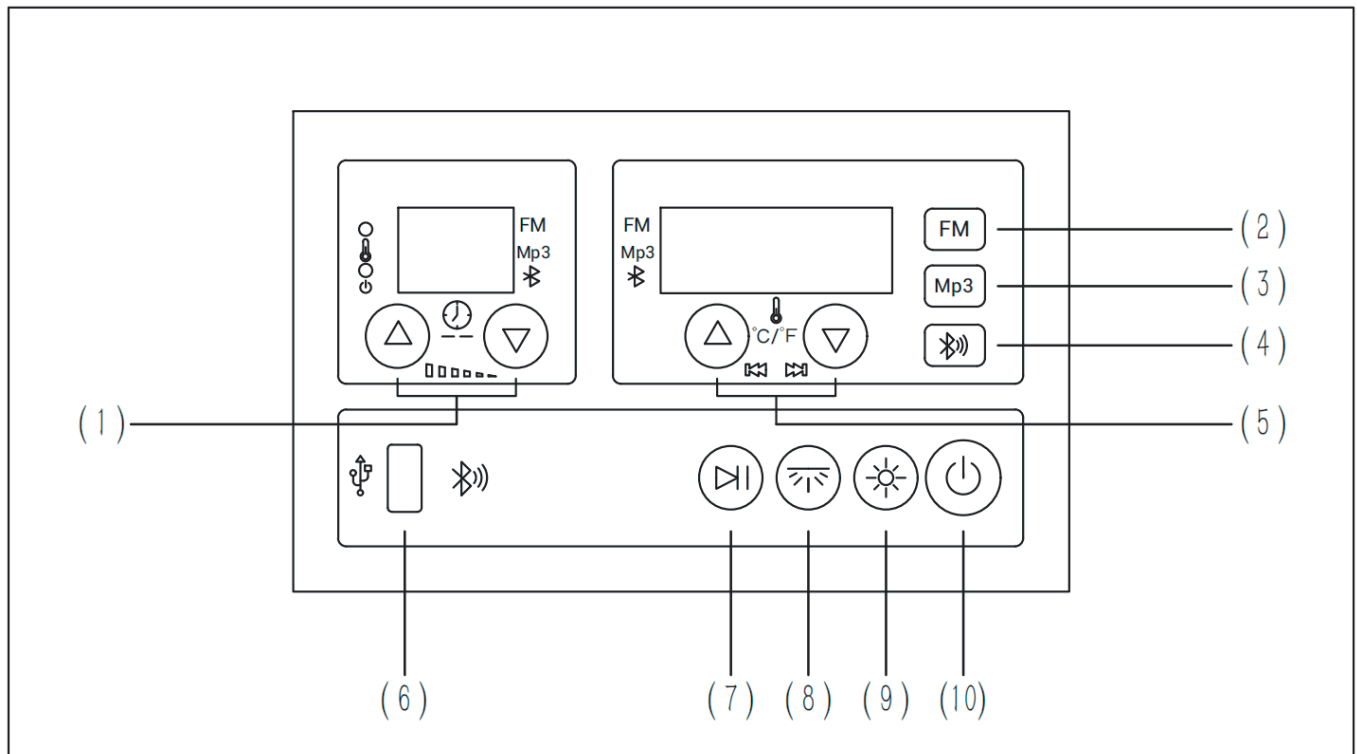

1. Timer / Volume Control

- When MP3/FM/BT mode is not active, press the **Time [Up/Down]** button to adjust the timer. Hold to change continuously.
- After setting, the system will automatically exit in about 3 seconds and return to the temperature display.
- When the timer reaches "00", the heater will stop and a beeping sound will occur 5 times.

2. FM Radio

- Press the **FM** button once to enter FM mode. The screen will display "F-" and the channel.
- Use **Temp [+/-]** (right side) to change channels, and **Time [+/-]** (left side) to adjust volume.
- Press **Play/Pause** to pause or resume the radio.
- Channel range: 76.0–108.0 MHz. While tuning, the display shows the current frequency (e.g., 103.3). After ~3 seconds, it will return to temperature and time display.

3. MP3 Audio

- Insert a USB drive (files must be in **.mp3** format). Press the **MP3** button to enter MP3 mode. The screen will display “**P-**” and playback starts from the first track.
- Use **Temp [+/-]** (right side) to select previous/next track. Use **Time [+/-]** (left side) to adjust volume.
- Press **Play/Pause** to pause or resume playback.
- When selecting a track, the temperature display shows the track number, and the time display shows track info. After ~3 seconds, the display returns to temperature and time.

4. Bluetooth Audio

- Press the **BT** button once to enter Bluetooth mode. The screen will display “**b-**”. After the prompt sound, search for the sauna’s Bluetooth name on your device to connect.
- Once connected (voice prompt: “*connected*”), play music from your device. Use **Play/Pause** to control playback.
- Use **Time [+/-]** (left side) to adjust volume.
- After ~5 seconds, the display automatically returns to temperature and time.
- Effective range: 10 m. If playback fails, disconnect Bluetooth on your device, unplug and reconnect the sauna, then pair again.

5. Temperature / Track Select / FM Channel Control

- When MP3/FM/BT mode is not active, press the **Temp [Up/Down]** button to adjust the temperature. Hold to change continuously.
- After ~3 seconds, the system will automatically exit and return to the actual temperature display.

6. USB Input

- Insert a USB flash drive into the port. Press the **MP3** button to play stored music.
- **Note:** Files must be in MP3 format.

7. Play / Pause Control

- Press this button to play or pause FM, MP3, or Bluetooth audio.

8. Light Control

(When the sauna is ON)

- 1st press – Reading light & ambient light ON
- 2nd press – Reading light OFF, ambient light ON

- 3rd press – Ambient light OFF, reading light ON
- 4th press – Both lights OFF

9. Chromotherapy Light Control

- When the sauna is ON, chromotherapy light starts in **Auto Color Cycle** mode (colors change gradually).
- Press once → Red. Continue pressing to cycle through: Blue → Green → Purple → Light Blue → Cyan → White → Auto Color Cycle → OFF.

10. Power On / Off

- **Power ON:** When the power cord is connected, the power indicator turns red. Press this button to turn on the sauna. The LCD will display the last set starting temperature and time, and all lights will turn on.
- **Power OFF:** Under normal operation, press this button again to turn off the sauna. Only the power indicator remains red.