

ASSEMBLY INSTRUCTIONS

INSTRUCTIONS DE MONTAGE

TWIN LOFT BED WITH DESK, SHELVES, STAIRS

LIT MANCHES JUMELLES AVEC BUREAU, ÉTAGÈRES,
ESCALIER

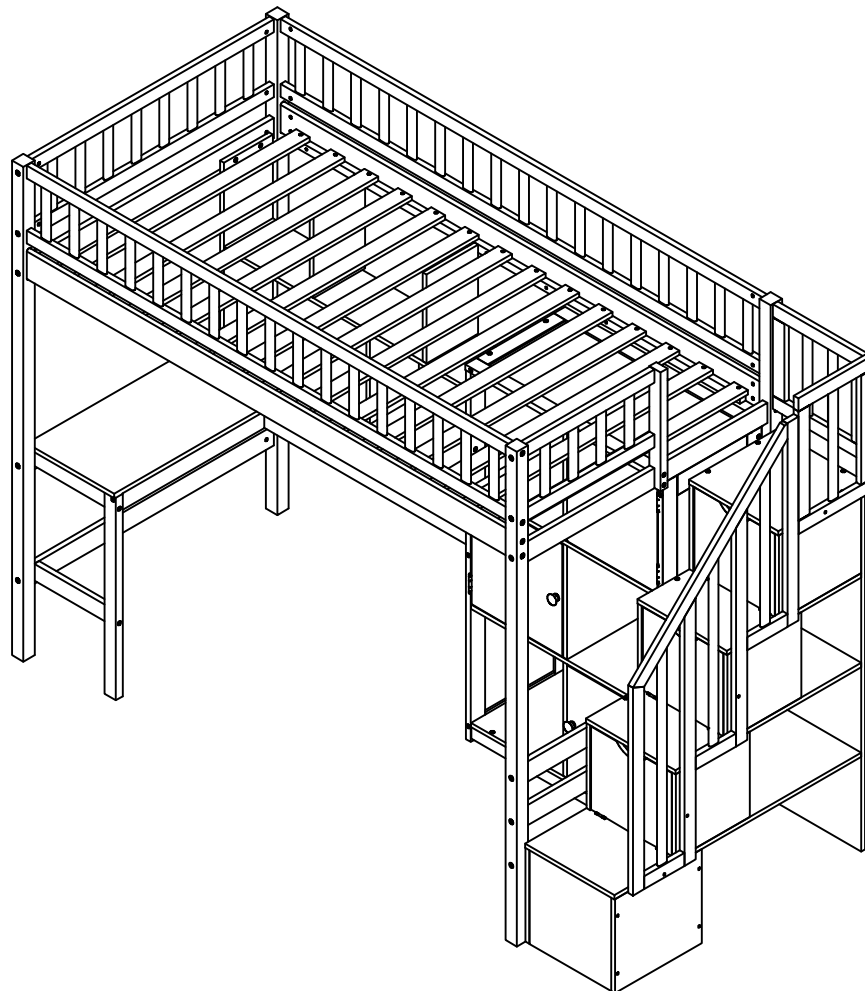

SAFETY WARNINGS AND GENERAL NOTES:

Follow the information on the warnings on the bunk bed end structure and on the carton. Do not remove the warning label from the bed. Always use the recommended size mattress on mattress support, or both, to help prevent the likelihood of entrapment or falls.

The top surface of the mattress must be at least 5*inch (127mm) below the upper edge of the guardrail.

Do not allow children under 6 years of age to use the upper bunk.

Periodically check and ensure the guardrail, ladder and other components are in their proper position, free from damage, and all connectors are tight.

Do not allow horseplay on or under beds.

Always prohibit jumping on the bed.

Prohibit more than one person on upper bunk.

Always use the ladder for entering and leaving the upper bunk.

Do not use substitute parts. Contact the manufacturer or dealer for replacement parts.

Use of a night-light may provide added safety precaution for a child using the upper bunk.

Always use guardrails on both long sides of the upper bunk.

If the bunk bed will be placed next to a wall, the guardrail that runs the full length of the bed should be placed against the wall to prevent entrapment between the bed and the wall.

The use of water or sleep flotation mattresses is prohibited.

STRANGULATION HAZARD-Never attach or hang items to any part of the bunk bed that are not designed for use with the bed.

Keep these instructions for future reference.

We recommend assembling your bunk bed on the shipping carton to protect your floor or carpet.

Be certain all staples are out of the box before beginning assembly on the shipping carton.

THIS BED IS DESIGNED TO USE A FULL MATTRESSES 38 1/2" WIDE X 74"-75" LONG WITH THE TOTAL THICKNESS NOT EXCEEDING 6" FOR UPPER BUNK, SURFACE OF MATTRESS MUST BE AT LEAST 5" (127MM) BELOW THE UPPER EDGE OF GUARDRAILS.

Replacement Parts:

Replacement Parts, including additional guardrails, may be obtained from any of our dealers.

AVERTISSEMENTS DE SÉCURITÉ ET REMARQUES GÉNÉRALES :

Suivez les informations sur les avertissements figurant sur la structure d'extrémité du lit superposé et sur le carton. Ne retirez pas l'étiquette d'avertissement du lit. Utilisez toujours le matelas de taille recommandée sur le support de matelas, ou les deux, pour éviter tout risque de coincement ou de chute.

La surface supérieure du matelas doit être à au moins 5*poûces (127 mm) sous le bord supérieur du garde-corps.

Ne laissez pas les enfants de moins de 6 ans utiliser le lit supérieur.

Vérifiez périodiquement et assurez-vous que le garde-corps, l'échelle et les autres composants sont dans leur bonne position, exempts de dommages et que tous les connecteurs sont bien serrés.

Ne permettez pas les chahuts sur ou sous les lits.

Interdisez toujours de sauter sur le lit.

Interdire plus d'une personne sur la couchette supérieure.

Utilisez toujours l'échelle pour entrer et sortir du lit supérieur.

N'utilisez pas de pièces de rechange. Contactez le fabricant ou le revendeur pour obtenir des pièces de rechange.

L'utilisation d'une veilleuse peut fournir une précaution supplémentaire en matière de sécurité pour un enfant utilisant le lit supérieur.

Utilisez toujours des garde-corps sur les deux côtés longs du lit supérieur.

Si le lit superposé doit être placé à côté d'un mur, le garde-corps qui s'étend sur toute la longueur du lit doit être placé contre le mur pour éviter tout coincement entre le lit et le mur.

L'utilisation de matelas flottants à eau ou de sommeil est interdite.

RISQUE D'ÉTRANGULATION - N'attachez ou ne suspendez jamais d'objets à une partie du lit superposé qui ne sont pas conçus pour être utilisés avec le lit.

Conservez ces instructions pour référence future.

Nous vous recommandons d'assembler votre lit superposé sur le carton d'expédition pour protéger votre sol ou votre tapis.

Assurez-vous que toutes les agrafes sont sorties de la boîte avant de commencer l'assemblage sur le carton d'expédition.

CE LIT EST CONÇU POUR UTILISER UN MATELAS COMPLET DE 38 1/2" DE LARGE X 74" - 75" DE LONG AVEC L'ÉPAISSEUR TOTALE NE DÉPASSANT PAS 6" POUR LE COUCHE SUPÉRIEUR, LA SURFACE DU MATELAS DOIT ÊTRE AU MOINS 5" (127 MM) EN DESSOUS DU BORD SUPÉRIEUR DES GARDE-CORPS.

Pièces de rechange :

Les pièces de rechange, y compris les garde-corps supplémentaires, peuvent être obtenues auprès de l'un de nos revendeurs.





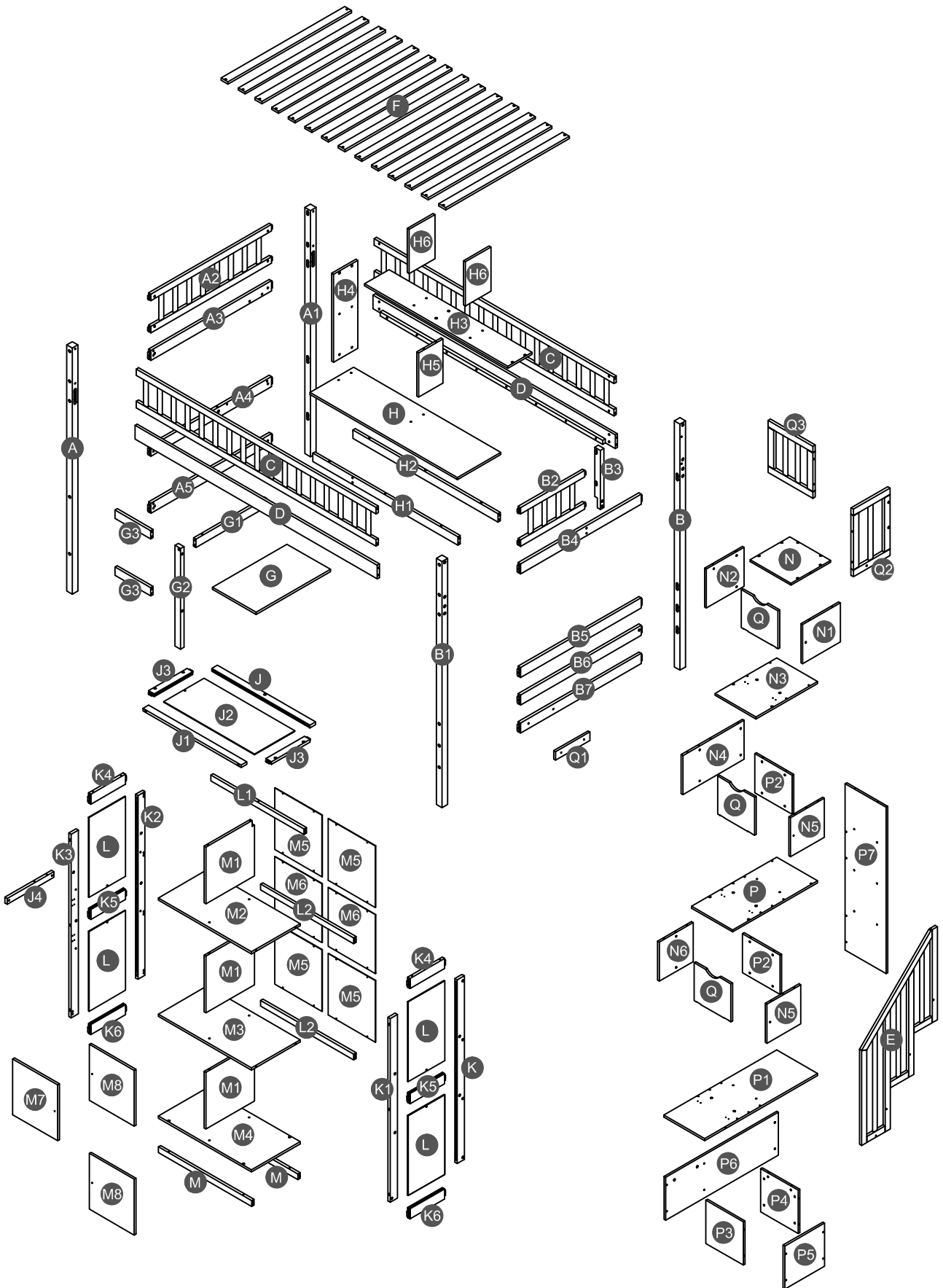

Detail View

Vue Détaillée

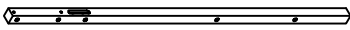
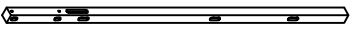
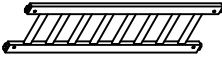
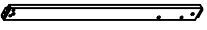
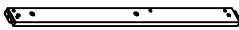
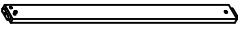
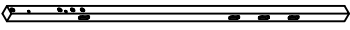
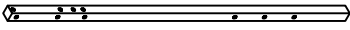
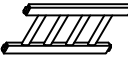
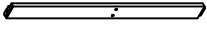
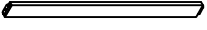

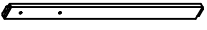
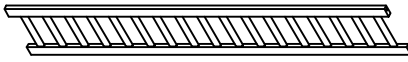
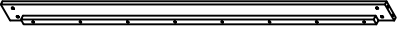

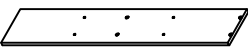
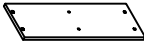









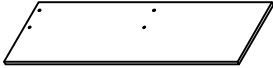
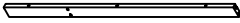
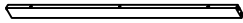
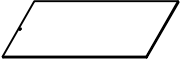

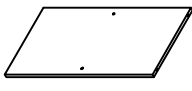
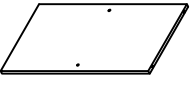
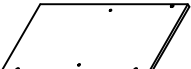

Part list (Box 1)

Liste des pièces (Boîte 1)

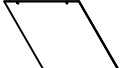
<p>A</p>  <p>Leg (Left Front) - 1pc Pied (Avant gauche)</p>	<p>A1</p>  <p>Leg (Left Back) - 1pc Pied (Arrière gauche)</p>	<p>A2</p>  <p>Frame HB - 1pc Cadre HB</p>
<p>A3</p>  <p>Upper horizontal bar HB - 1pc Barre horizontale supérieure HB</p>	<p>A4</p>  <p>Divider horizontal bar HB - 1pc Barre de séparation horizontale HB</p>	<p>A5</p>  <p>Lower horizontal bar HB - 1pc Barre horizontale inférieure HB</p>
<p>B</p>  <p>Leg (Right Back) - 1pc Pied (arrière droit)</p>	<p>B1</p>  <p>Leg (Right Front) - 1pc Pied (Avant droit)</p>	<p>B2</p>  <p>Frame FB - 1pc Cadre FB</p>
<p>B4</p>  <p>Upper horizontal bar FB - 1pc Barre horizontale supérieure FB</p>	<p>B5</p>  <p>Divider horizontal bar FB - 1pc Barre de séparation horizontale FB</p>	<p>B6</p>  <p>Divider horizontal bar FB - 1pc Barre de séparation horizontale FB</p>
<p>B7</p>  <p>Lower horizontal bar FB - 1pc Barre horizontale inférieure FB</p>	<p>C</p>  <p>Guard rail - 2pcs Garde-corps</p>	<p>D</p>  <p>Upper side rail - 2pcs Rail latéral supérieur</p>
<p>F</p>  <p>Slats - 14pcs Lattes</p>	<p>H3</p>  <p>Shelf panel - 1pc Panneau d'étagère</p>	<p>H4</p>  <p>Side panel (left) - 1pc Panneau latéral (gauche)</p>
<p>H5</p>  <p>Lower divider panel - 1pc Panneau de séparation inférieur</p>		



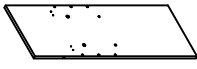
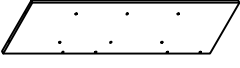







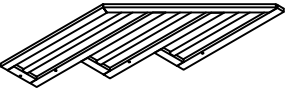
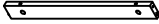









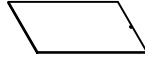

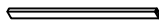
Part list & Hardware list (Box 2)

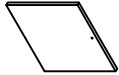
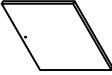

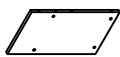
Liste des pièces & liste du matériel (Boîte 2)

<p>B3</p>  <p>Vertical guard rail FB - 1pc Garde-corps vertical FB</p>	<p>G</p>  <p>Top table - 1pc Table haute</p>	<p>G2</p>  <p>Leg (front) - 1pc Pied (avant)</p>
<p>H</p>  <p>Top table - 1pc Table haute</p>	<p>H1</p>  <p>Horizontal bar (front) - 1pc Barre horizontale (avant)</p>	<p>H2</p>  <p>Horizontal bar (back) - 1pc Barre horizontale (arrière)</p>
<p>J2</p>  <p>Top panel - 1pc Panneau supérieur</p>	<p>K</p>  <p>Vertical bar (Right back)- 1pc Barre verticale (arrière droit)</p>	<p>K1</p>  <p>Vertical bar (Right Front)- 1pc Barre verticale (Avant droit)</p>
<p>K2</p>  <p>Vertical bar (Left back)- 1pc Barre verticale (Arrière gauche)</p>	<p>K3</p>  <p>Vertical bar (Left Front)- 1pc Barre verticale (Avant gauche)</p>	<p>M1</p>  <p>Divider panel - 3pcs Panneau de séparation inférieur</p>
<p>M2</p>  <p>Upper shelf panel - 1pc Panneau d'étagère supérieur</p>	<p>M3</p>  <p>Lower shelf panel - 1pc Panneau d'étagère inférieur</p>	<p>M4</p>  <p>Bottom panel - 1pc Panneau inférieur</p>
<p>M5</p>  <p>Back panel (upper & lower) - 4pcs Panneau arrière (supérieur et inférieur)</p>	<p>M6</p>  <p>Divider back panel - 2pcs Panneau arrière séparateur</p>	<p>N</p>  <p>Upper step ladder panel -1pc Panneau d'échelle supérieur</p>
<p>N3</p>  <p>Upper center step ladder panel -1pc Panneau d'échelle central supérieur</p>	<p>P</p>  <p>Center step ladder panel -1pc Panneau d'échelle à marchepied central</p>	<p>P1</p>  <p>Lower step ladder panel -1pc Panneau d'échelle inférieur</p>
<p>P7</p>  <p>Back panel - 1pc Panneau arrière</p>	<p>Q1</p>  <p>Support - 1pc Support</p>	

Part list (Box 3)

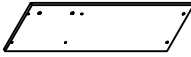

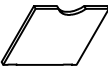
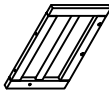









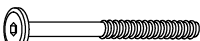
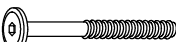
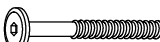

Liste des pièces (Boîte 3)





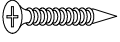

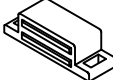

<p>E</p>  <p>Guard rail (front) - 1pc Garde-corps (avant)</p>	<p>G1</p>  <p>Horizontal bar - 1pc Barre horizontale</p>	<p>G3</p>  <p>Horizontal bar (front) - 2pcs Barre horizontale (avant)</p>
<p>H6</p>  <p>Upper divider panel - 2pcs Panneau séparateur supérieur</p>	<p>J</p>  <p>Horizontal bar (back) - 1pc Barre horizontale (arrière)</p>	<p>J1</p>  <p>Horizontal bar (front) - 1pc Barre horizontale (avant)</p>
<p>J3</p>  <p>Horizontal bar (left/right) - 2pcs Barre horizontale (gauche/droite)</p>	<p>J4</p>  <p>Support - 1pc Support</p>	<p>K4</p>  <p>Upper horizontal bar - 2pcs Barre horizontale supérieure</p>
<p>K5</p>  <p>Divider horizontal bar - 2pcs Barre de séparation horizontale</p>	<p>K6</p>  <p>Lower horizontal bar - 2pcs Barre horizontale inférieure</p>	<p>L</p>  <p>Side panel - 4pcs Panneau latéral</p>
<p>L1</p>  <p>Upper horizontal bar - 1pc Barre horizontale supérieure</p>	<p>L2</p>  <p>Divider horizontal bar - 2pcs Barre de séparation horizontale</p>	<p>M</p>  <p>Lower horizontal bar - 2pcs Barre horizontale inférieure</p>
<p>M7</p>  <p>Door (left) - 1pc Porte (gauche)</p>	<p>M8</p>  <p>Door (right) - 2pcs Porte (droit)</p>	<p>N1</p>  <p>Upper right side panel - 1pc Panneau latéral supérieur droit</p>
<p>N2</p>  <p>Upper left side panel - 1pc Panneau latéral supérieur gauche</p>	<p>N4</p>  <p>Upper center left side panel - 1pc Panneau latéral supérieur central gauche</p>	<p>N5</p>  <p>Center right side panel - 2pcs Panneau latéral droit central</p>
<p>N6</p>  <p>Center left side panel - 1pc Panneau latéral central gauche</p>	<p>P2</p>  <p>Center panel - 2pcs Panneau central</p>	<p>P3</p>  <p>Lower front panel - 1pc Panneau avant inférieur</p>
<p>P4</p>  <p>Lower center panel - 1pc Panneau central inférieur</p>	<p>P5</p>  <p>Lower right side panel - 1pc Panneau latéral inférieur droit</p>	<p>P6</p>  <p>Lower left side panel - 1pc Panneau latéral inférieur gauche</p>

<p>Q</p>  <p>Upper front panel - 3pcs Panneau avant supérieur</p>	<p>Q2</p>  <p>Guard rail (Back) - 1pc Garde-corps (arrière)</p>	<p>Q3</p>  <p>Guard rail (Back) - 1pc Garde-corps (arrière)</p>
---	---	---

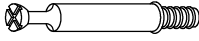
Hardware List (Box 2)

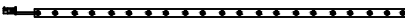
Liste du matériel (Boîte 2)

<p>1</p>  <p>Ø8*30mm</p> <p>Wood dowel (46pcs) Cheville en bois</p>	<p>2</p>  <p>(Ø15)1/4"*100mm</p> <p>Hex-Head bolts (16pcs) Boulons à tête hexagonale</p>	<p>3</p>  <p>(Ø15)1/4"*80mm</p> <p>Hex-Head bolts (25pcs) Boulons à tête hexagonale</p>
<p>4</p>  <p>(Ø12)1/4"*70mm</p> <p>Hex-Head bolts (2pcs) Boulons à tête hexagonale</p>	<p>5</p>  <p>(Ø12)1/4"*60mm</p> <p>Hex-Head bolts (83pcs) Boulons à tête hexagonale</p>	<p>6</p>  <p>(Ø12)1/4"*40mm</p> <p>Hex-Head bolts (2pcs) Boulons à tête hexagonale</p>
<p>7</p>  <p>(Ø12)1/4"*35mm</p> <p>Hex-Head bolts (2pcs) Boulons à tête hexagonale</p>	<p>8</p>  <p>(Ø12)1/4"*30mm</p> <p>Hex-Head bolts (7pcs) Boulons à tête hexagonale</p>	<p>9</p>  <p>1/4"*15 (9.5mm)</p> <p>Horizontal-Hole bolts(124pcs) Boulons à trou horizontal</p>
<p>10</p>  <p>(Ø12)1/4"*65mm</p> <p>Hex-Head bolts (16pcs) Boulons à tête hexagonale</p>	<p>11</p>  <p>(Ø12)1/4"*50mm</p> <p>Hex-Head bolts (2pcs) Boulons à tête hexagonale</p>	<p>12</p>  <p>(Ø12)1/4"*40mm</p> <p>Hex-Head bolts (13pcs) Boulons à tête hexagonale</p>
<p>13</p>  <p>Ø4*30mm</p> <p>Wood screws (28pcs) Vis</p>	<p>14</p>  <p>Ø3.5*15mm</p> <p>Wood screws (76pcs) Vis</p>	<p>15</p>  <p>Ø3.5*15mm</p> <p>Wood screws (25pcs) Vis</p>
<p>16</p>  <p>66*39*28mm (135°)</p> <p>Metal bracket (6pcs) Support métallique</p>	<p>17</p>  <p>42*12*1mm</p> <p>Metal magnet (6pcs) Aimant en métal</p>	<p>18</p>  <p>45*17*13mm</p> <p>Door catch (6pcs) Loquet de porte</p>

19  Ø38*31mm	20  3/16"*25mm	21  Ø7"*35mm
Pine Knob (3pcs) Poignée pin	Ph zinc(Knob) (3pcs) Boulons (Poignée)	Cam lock (10pcs) Serrure à came
22  Ø14*9mm	23  28*28*24*2mm	24  L1000mm
Cam lock (10pcs) Serrure à came	Metal bracket (2pcs) Support métallique	Led light (1pc) Lumière LED
25  2000mm	26  L124*40*7mm	27  22*10*6mm
Adapter and wire strip (1pc) Adaptateur et dénukeur de fils	Remote led light (1pc) Lumière LED à distance	Clamp plastic (1pc) Pince en plastique
28  (1/4")4.5*58mm		
Allen key (1pc) Clé Allen		

ASSEMBLY TOOLS REQUIRED (NOT INCLUDED)
OUTILS D'ASSEMBLAGE REQUIS (NON INCLUS)

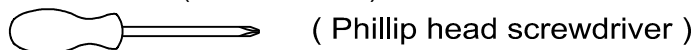

PLEASE BE CAREFUL DO NOT DAMAGE THE HOLE POSITION WHEN YOU USE POWER TOOLS !
NE PAS UTILISEZ DES OUTILS ÉLECTRIQUES POUR ASSEMBLER CE PRODUIT !

STEP 1:

ÉTAPE

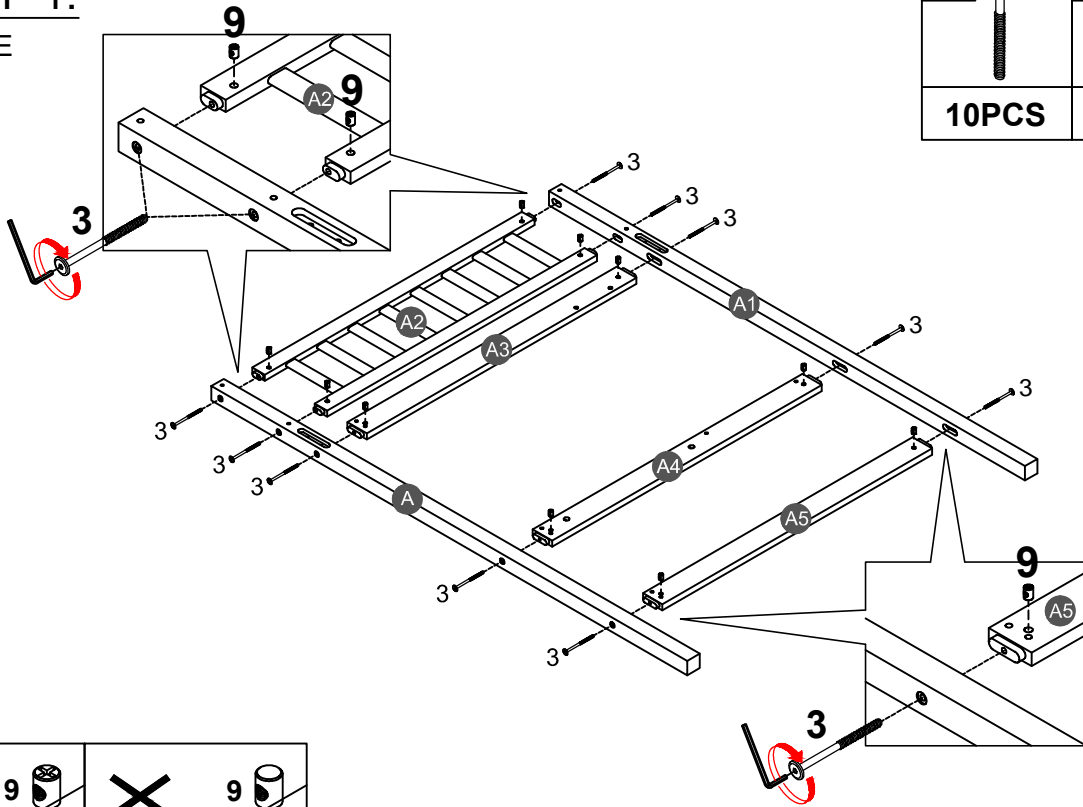

3		9	
10PCS		10PCS	

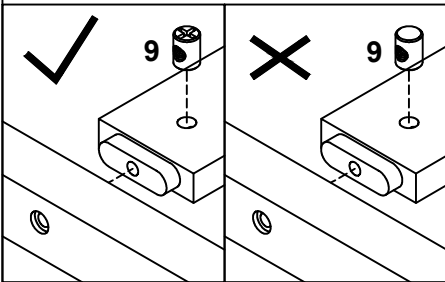

Note: Part 9 will face up with the "x" mark on it, otherwise it cannot be tightened

Remarque: La pièce 9 sera face vers le haut avec la marque "x", sinon elle ne peut pas être serrée.

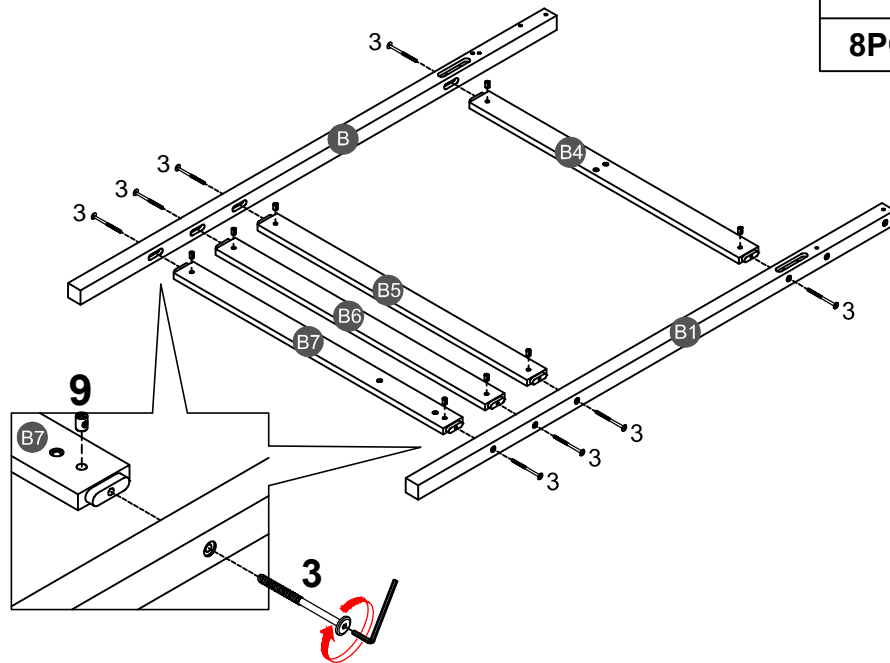

STEP 2:

ÉTAPE





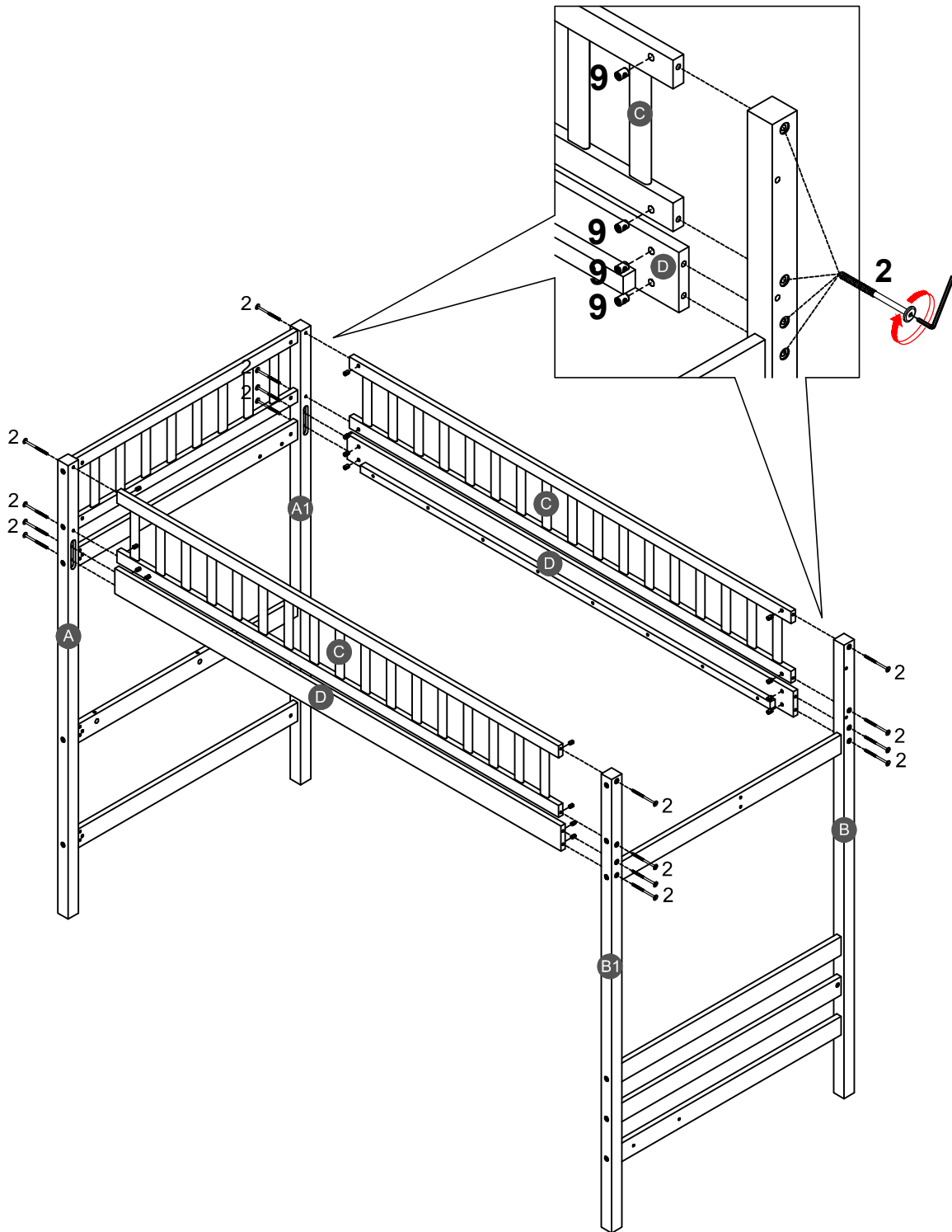

3		9	
8PCS		8PCS	

STEP 3:
ÉTAPE

2		9	
16PCS		16PCS	



STEP 4:
ÉTAPE

3		4		7		9	
2PCS		2PCS		2PCS		4PCS	

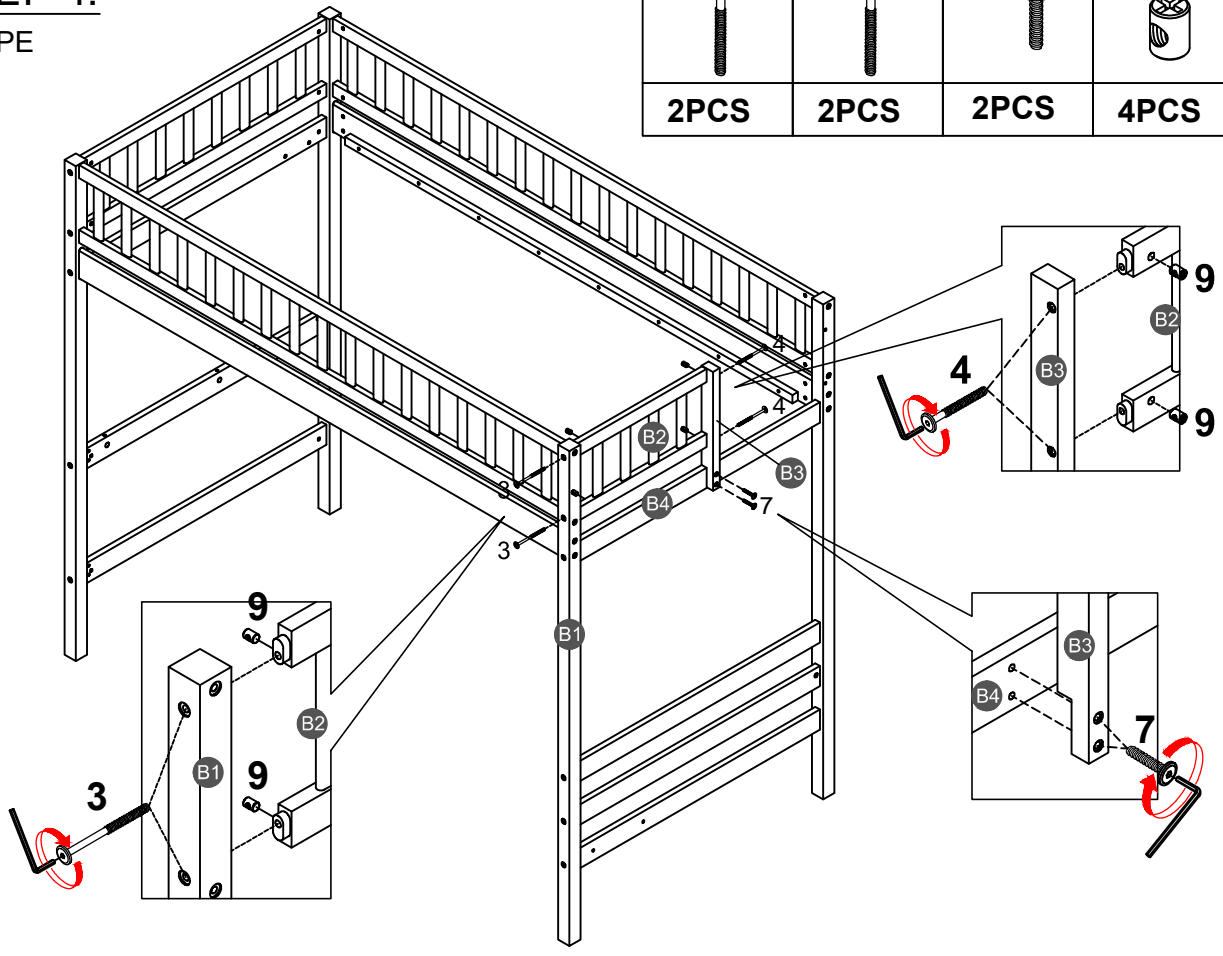

STEP 5:
ÉTAPE

10		14		18	
4PCS		2PCS		1PC	

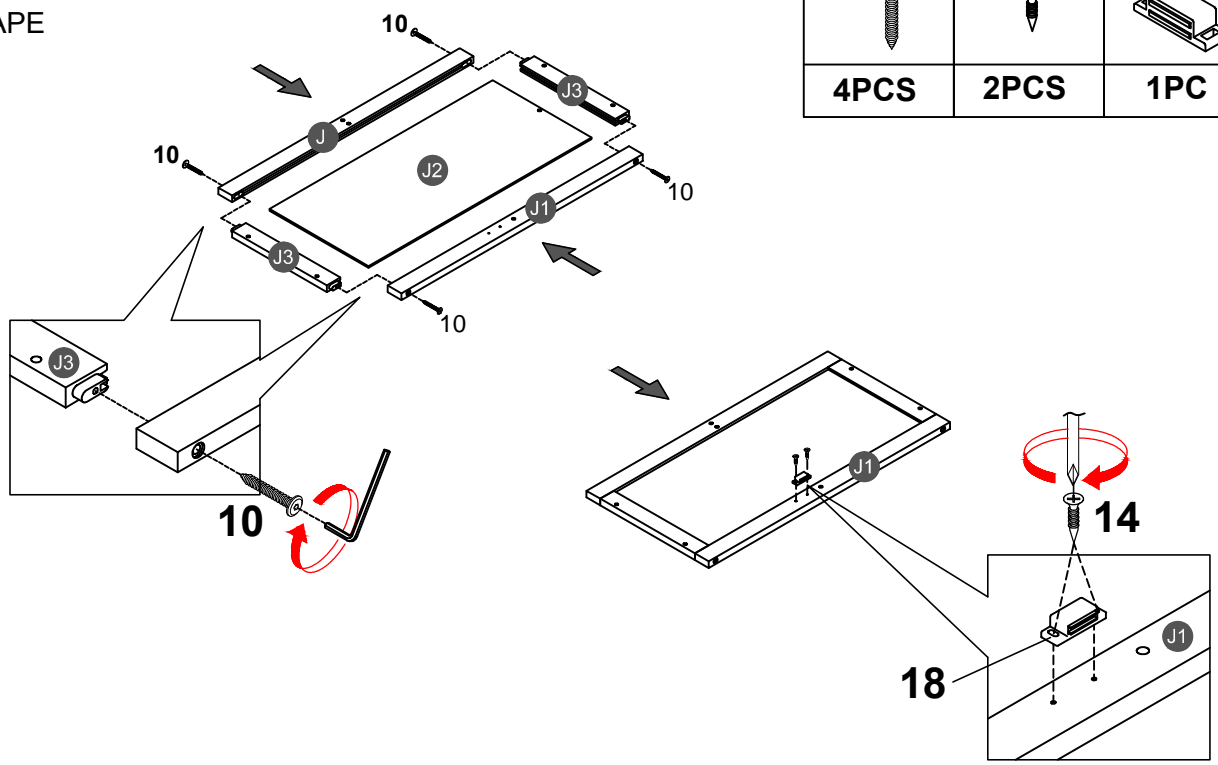

STEP 6:

ÉTAPE

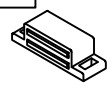
14		18	
4PCS		2PCS	

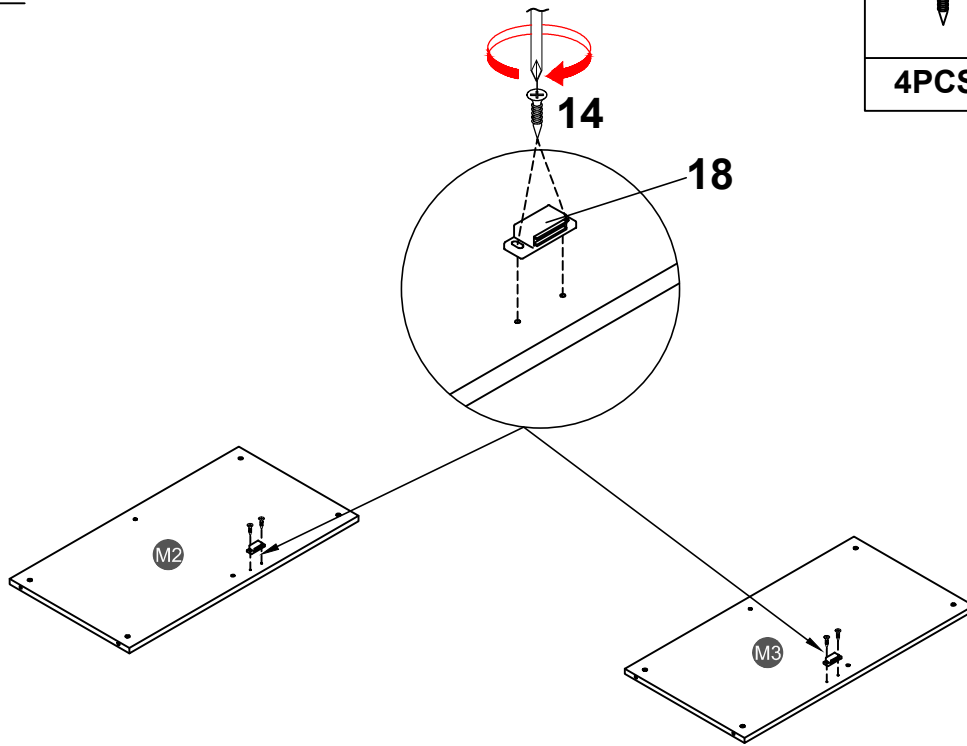

STEP 7:

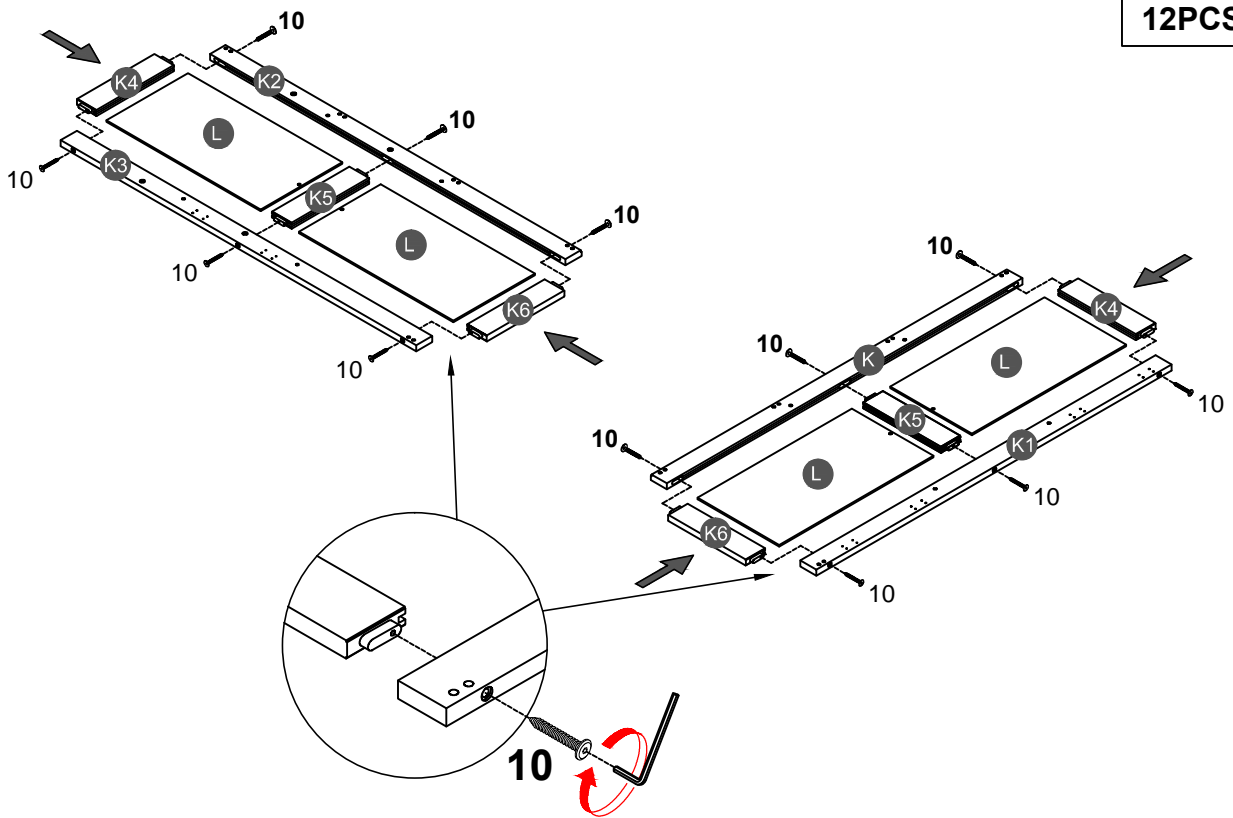

ÉTAPE

10	
12PCS	



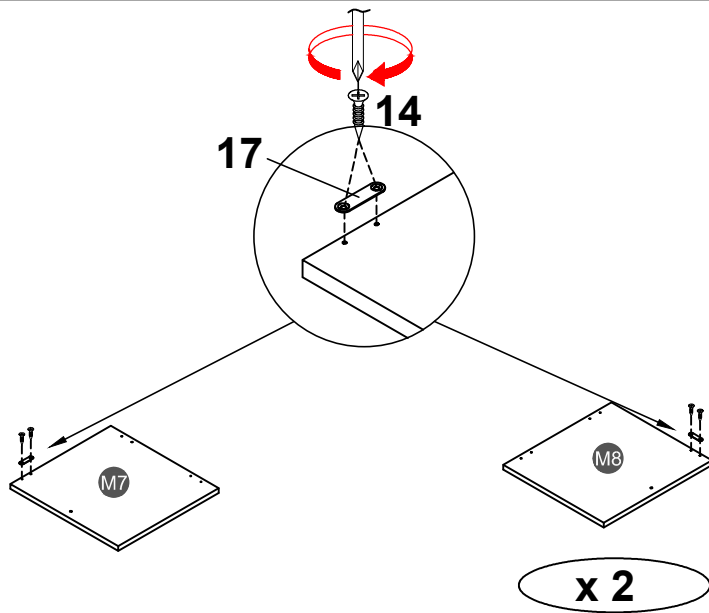

STEP 8:
ÉTAPE



14	17
	
6PCS	3PCS

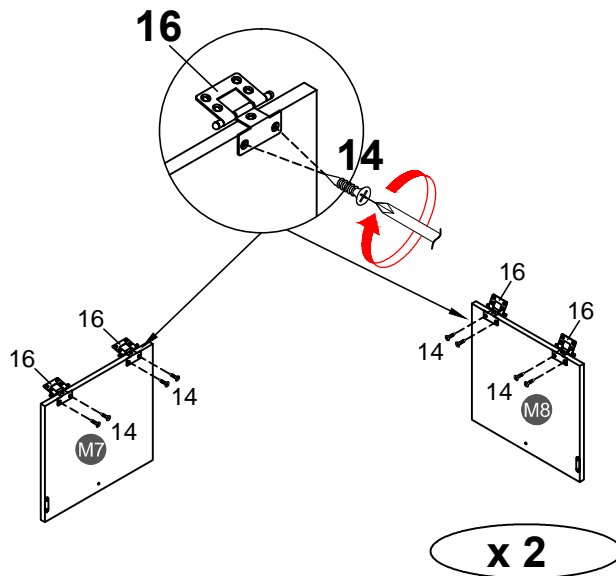

STEP 9:
ÉTAPE

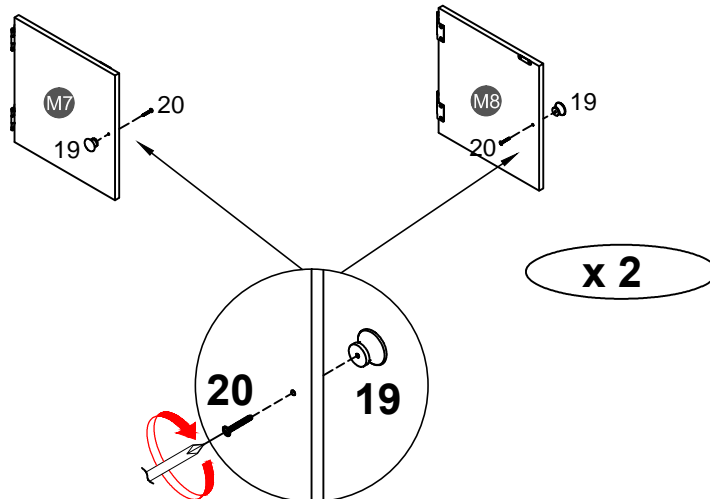

14	16
	
12PCS	6PCS

STEP 10:
ÉTAPE



19	20
	
3PCS	3PCS

STEP 11:

ÉTAPE

12



4PCS

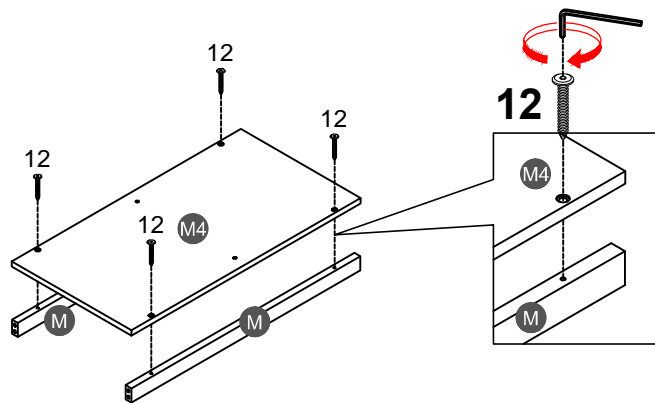

STEP 12:

ÉTAPE

1



10PCS

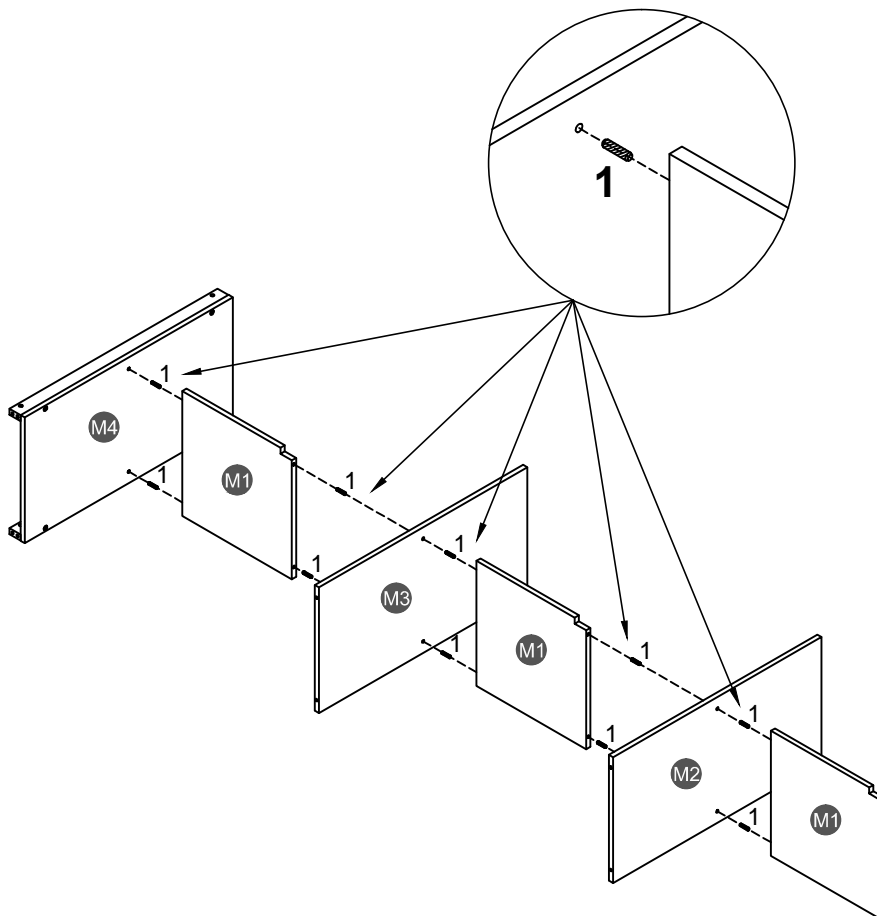

STEP 13:

ÉTAPE

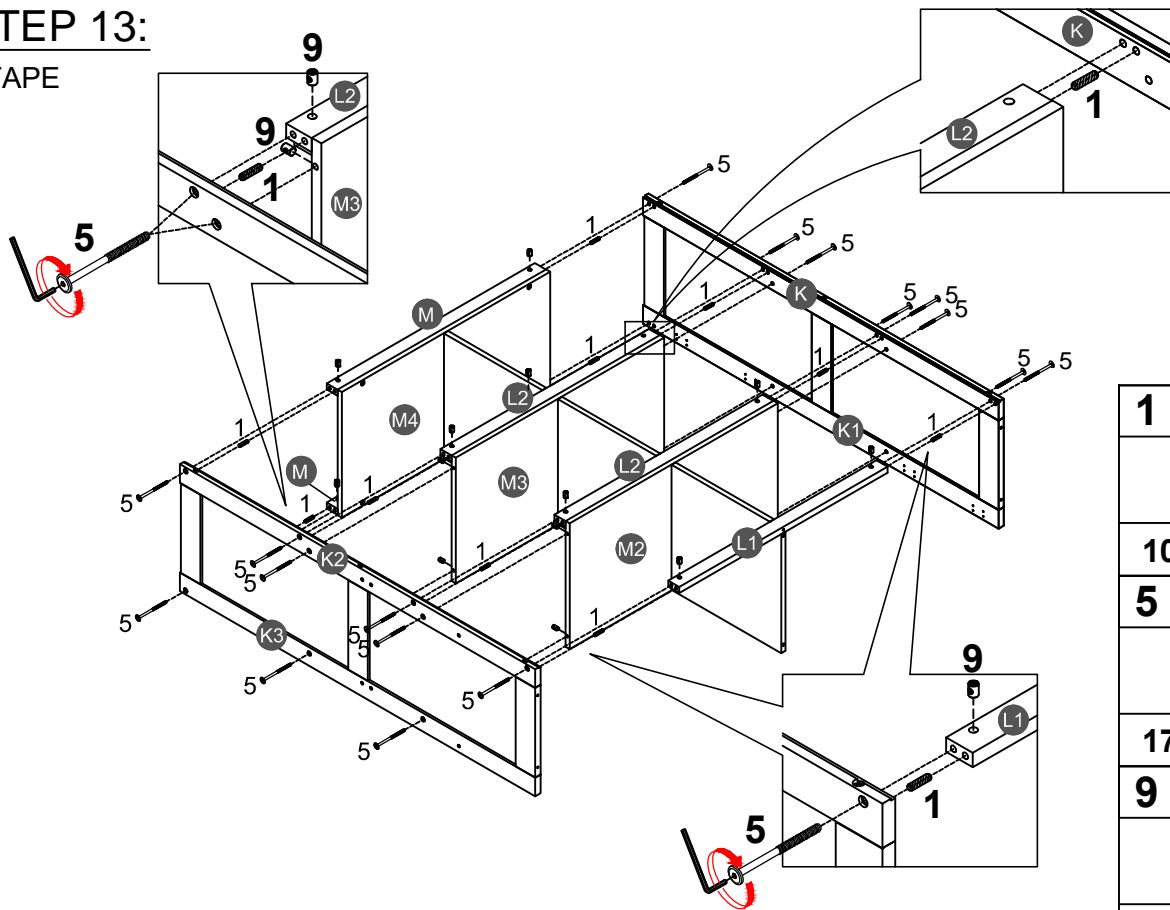

1	
10PCS	
5	
17PCS	
9	
17PCS	

STEP 14:

ÉTAPE

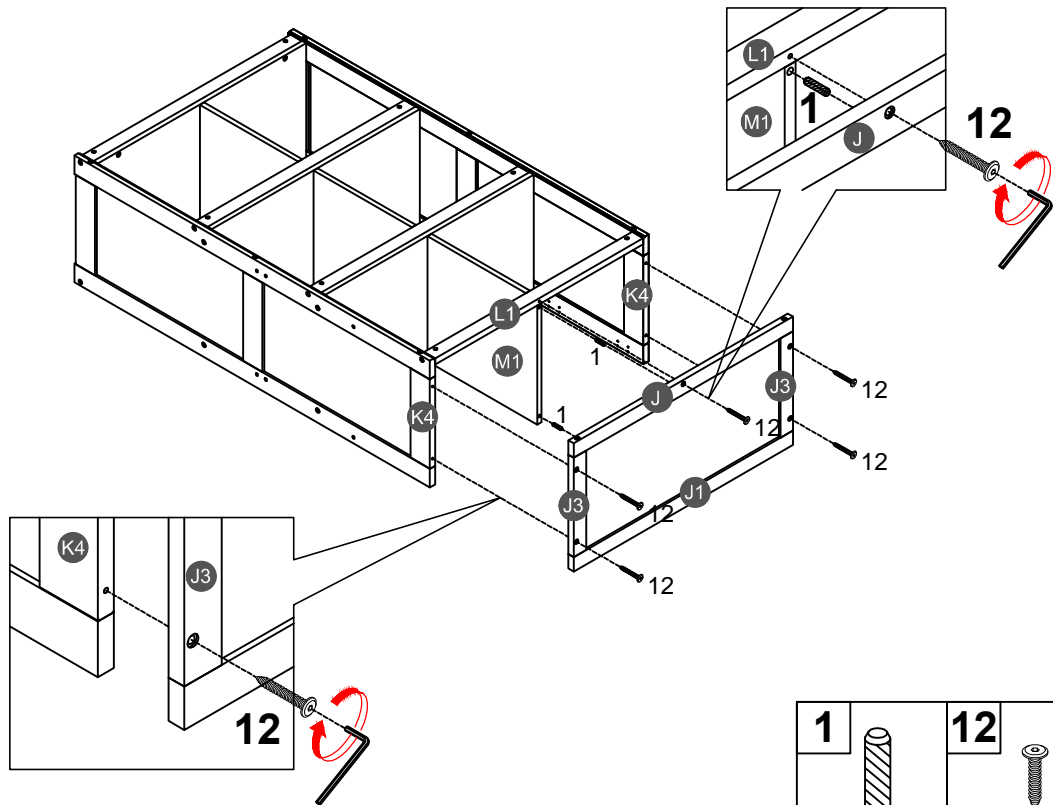

1		12	
2PCS		5PCS	

STEP 15:

ÉTAPE

14



24PCS

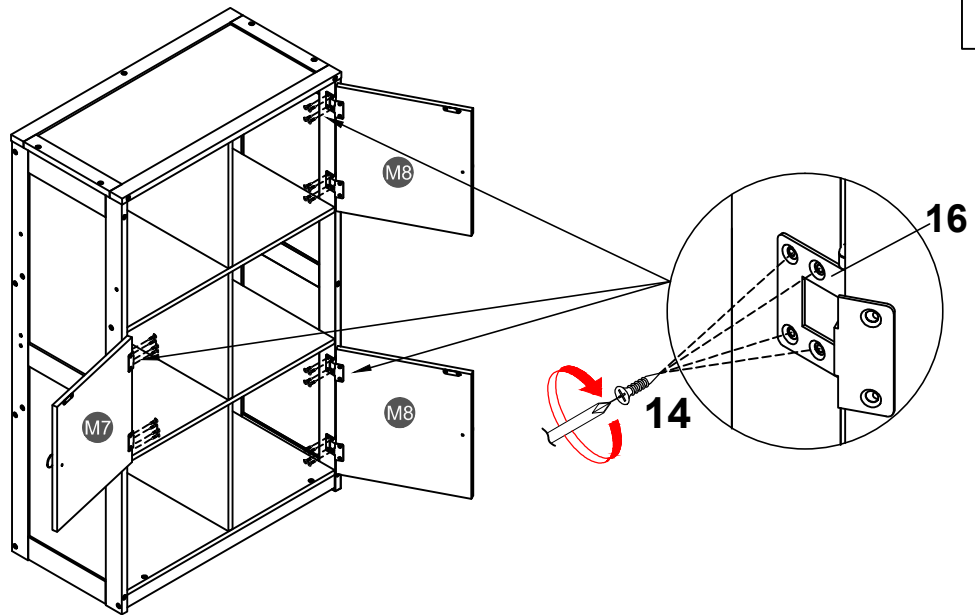

STEP 16:

ÉTAPE

8



2PCS

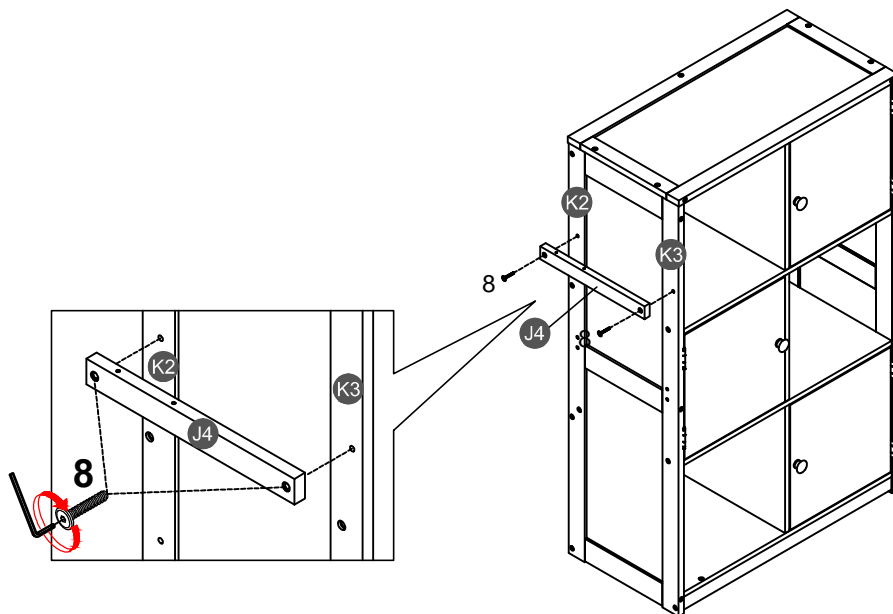

STEP 17:

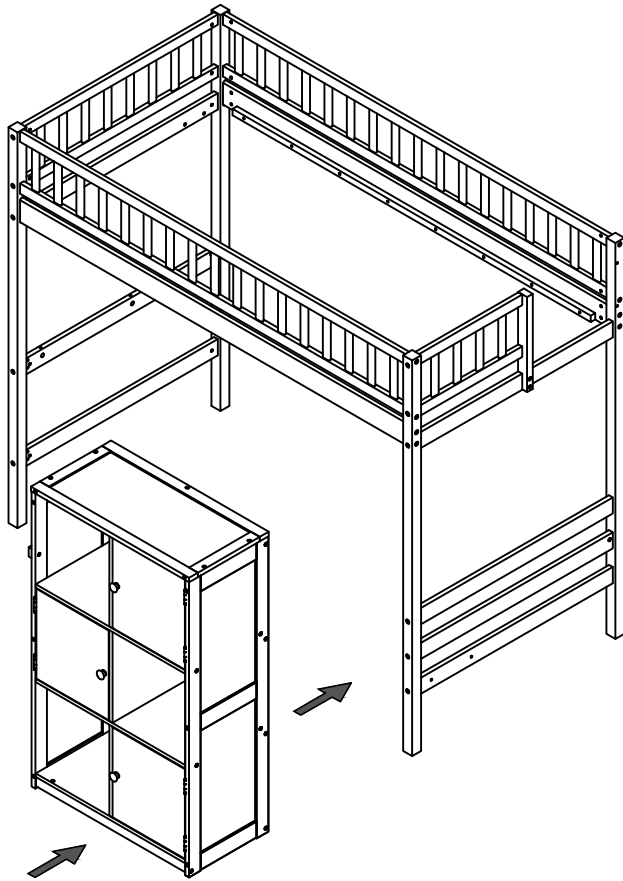

ÉTAPE

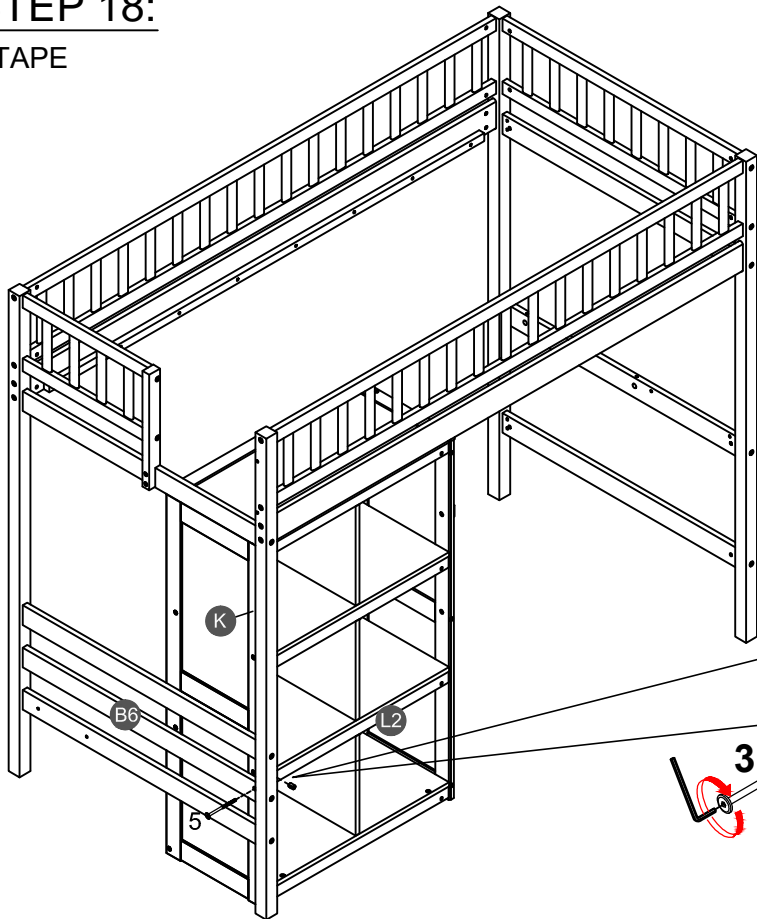

STEP 18:

ÉTAPE



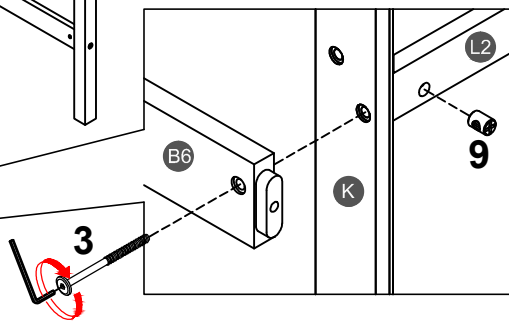

3		9	
1PC		1PC	



STEP 19:

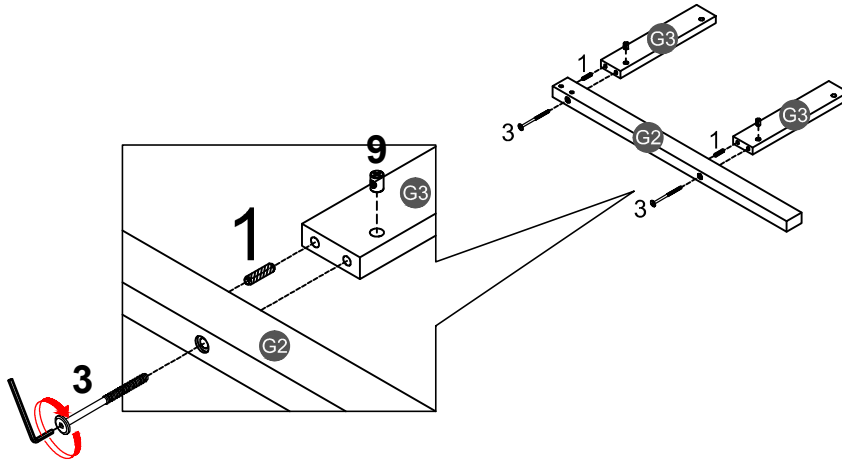

ÉTAPE

1		3		9	
2PCS		2PCS		2PCS	



STEP 20:

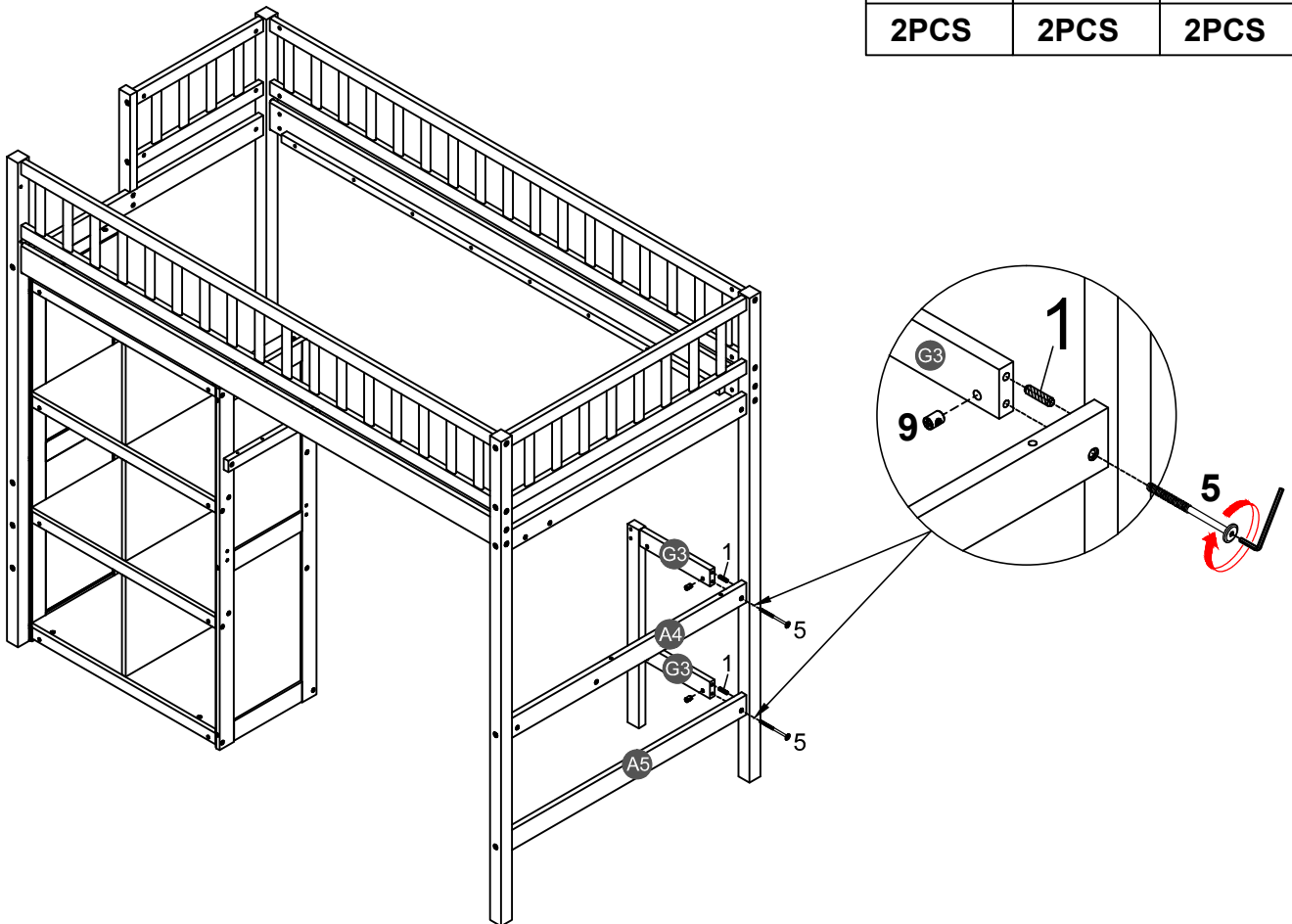

ÉTAPE

1		5		9	
2PCS		2PCS		2PCS	

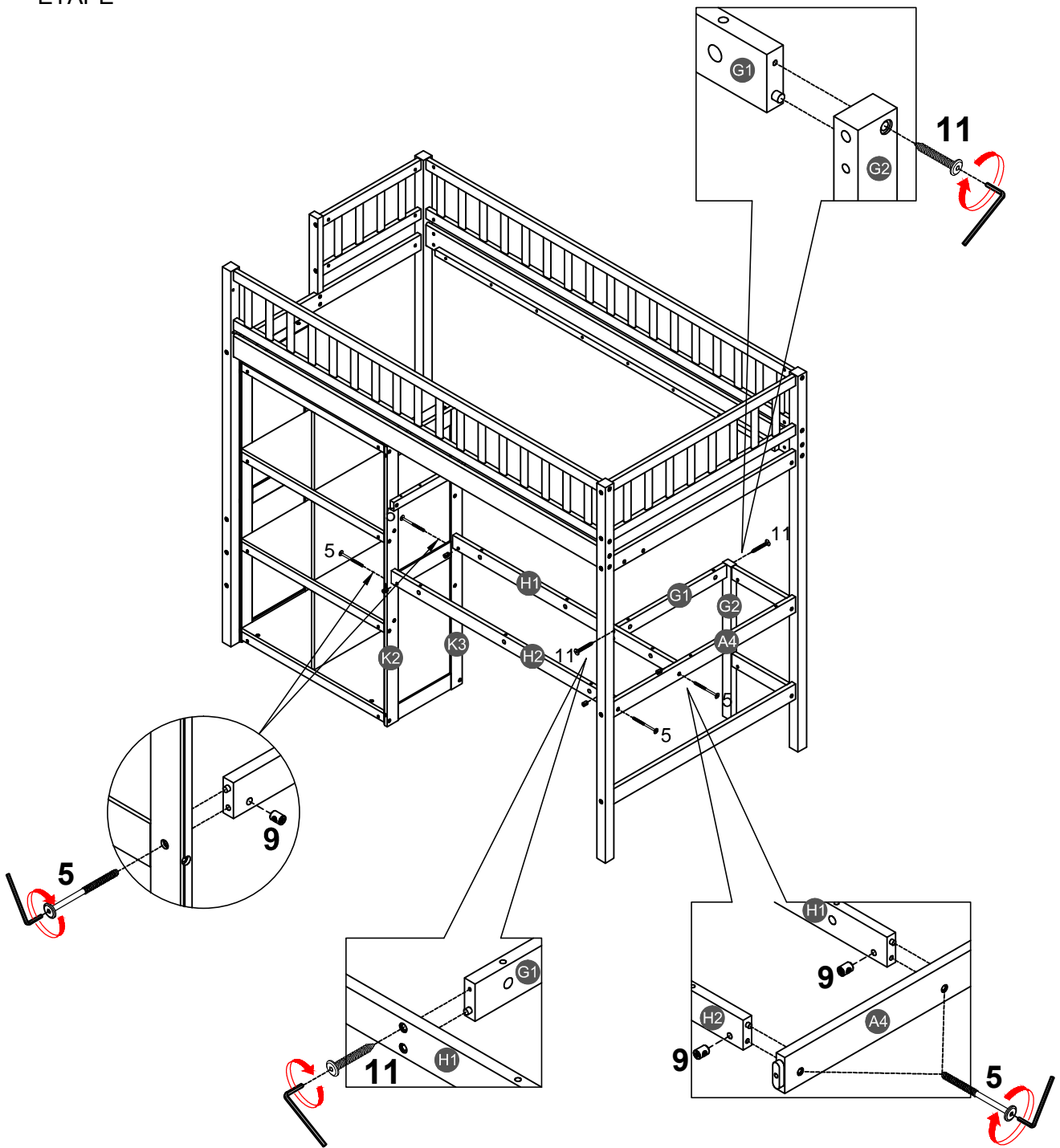

STEP 21:
ÉTAPE



5 	9 	11 
4PCS	4PCS	2PCS

STEP 22:

ÉTAPE

21

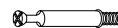

10PCS

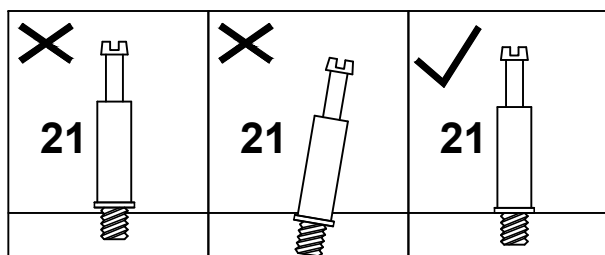
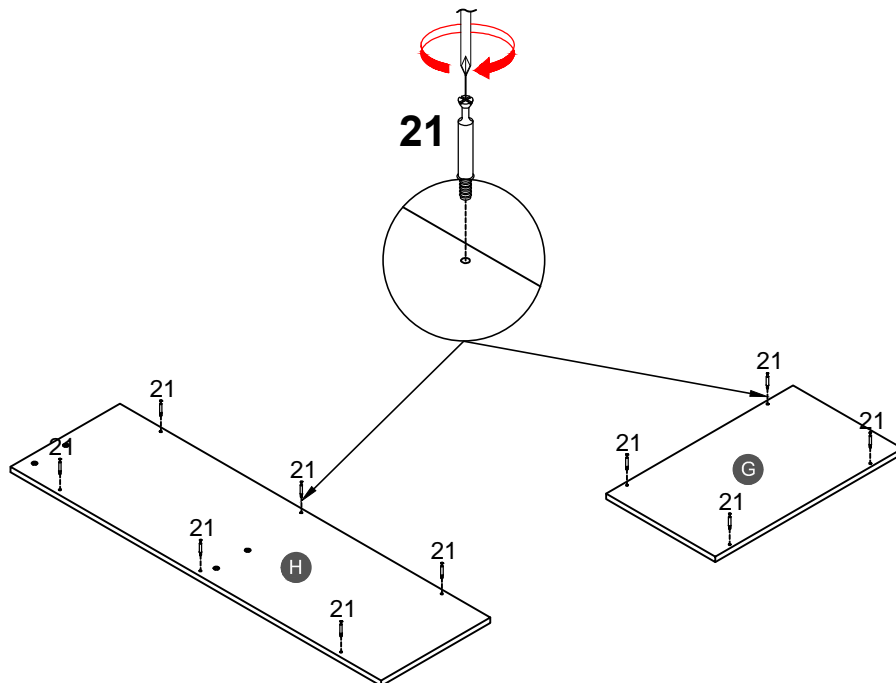

STEP 23:

ÉTAPE

22



10PCS

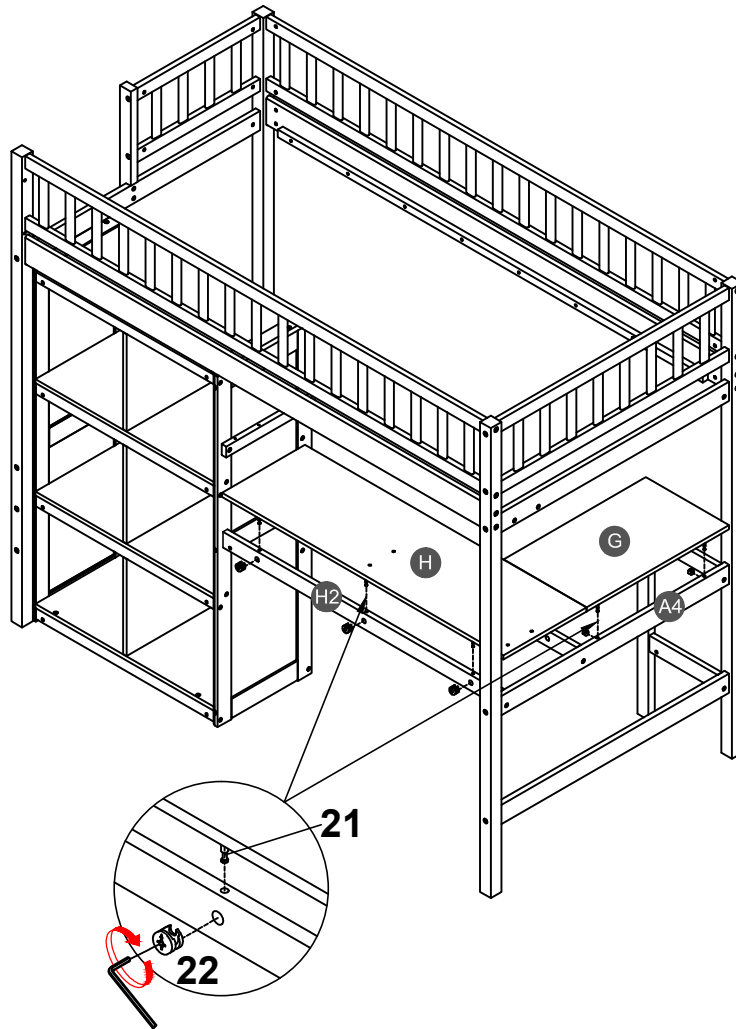

Note: Place hardware #22 with the "X" face outward, and make sure that the arrowhead is upward. Then, place hardware #22 into the hole of hardware #21 and tighten it clockwise with a hand screwdriver. (Please do NOT use an electric screwdriver.)

Remarque : placez la quincaillerie #22 avec la face « X » vers l'extérieur, et assurez-vous que la pointe de la flèche est vers le haut. Ensuite, placez le matériel #22 dans le trou de la quincaillerie #21 et serrez-le dans le sens des aiguilles d'une montre avec un tournevis à main. (Veuillez ne PAS utiliser de tournevis électrique.)

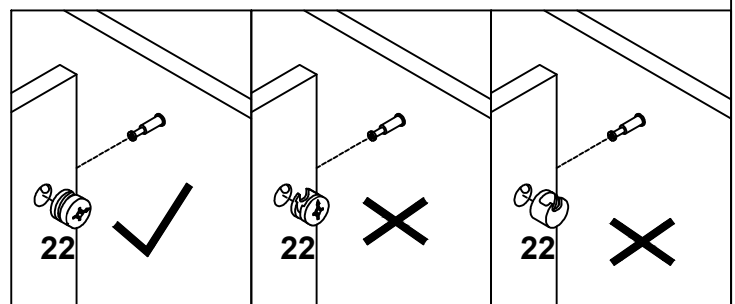

STEP 24:

ÉTAPE

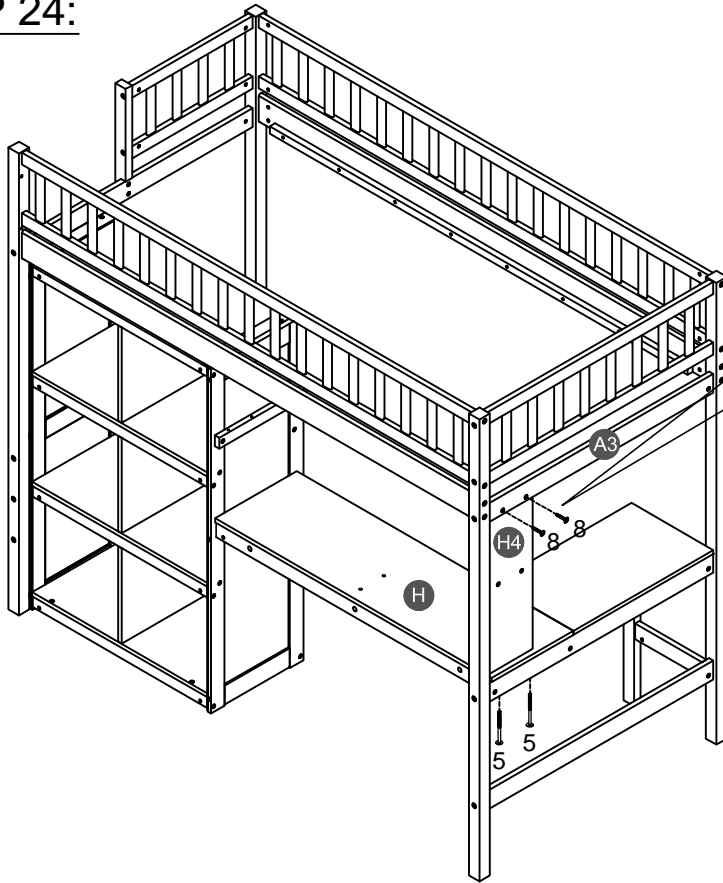

5		8		9	
2PCS		2PCS		2PCS	

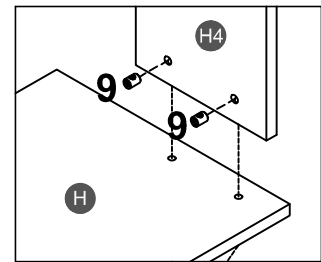
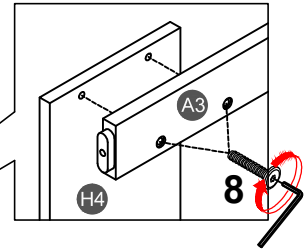

STEP 25:

ÉTAPE

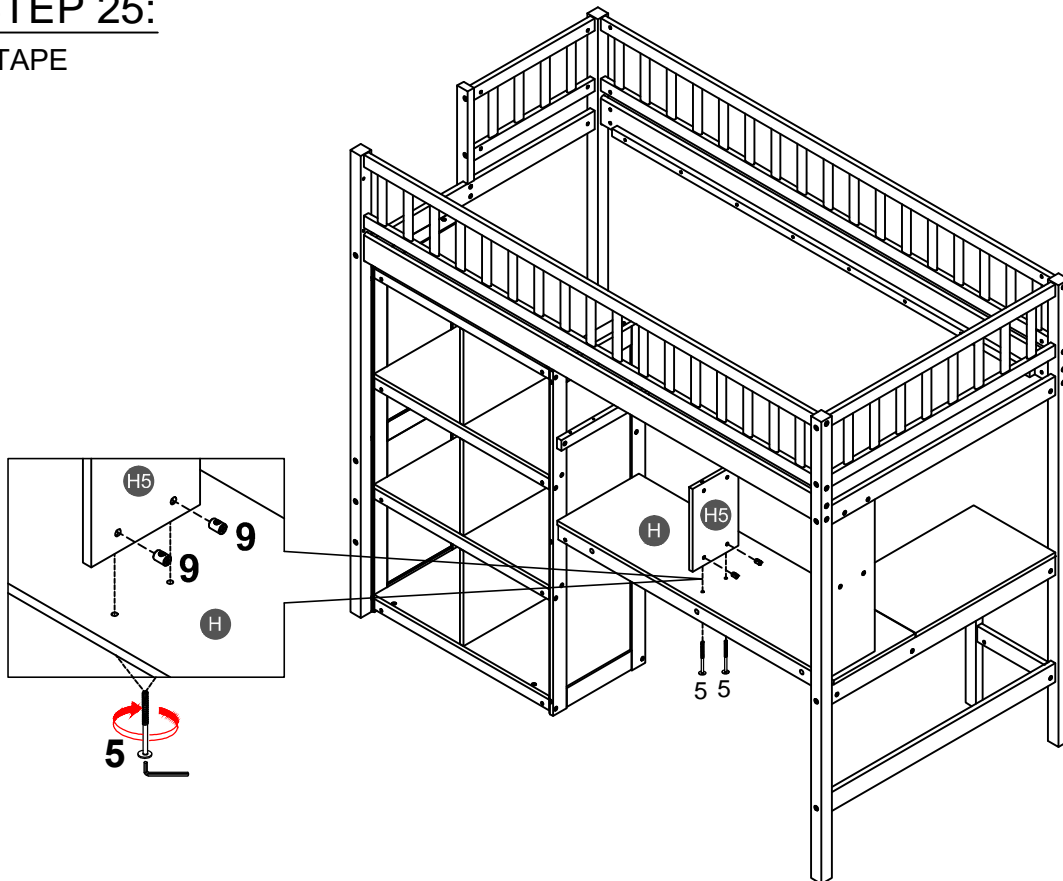

5	
2PCS	
9	
2PCS	

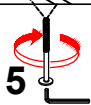
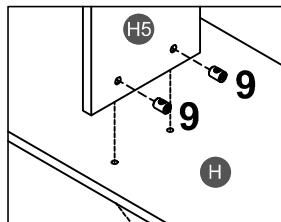

STEP 26:

ÉTAPE

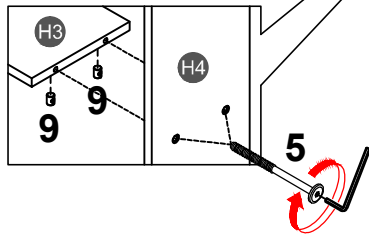
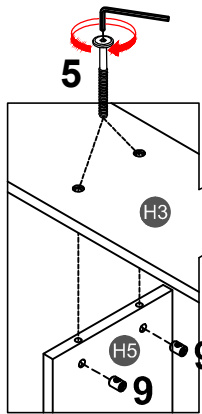
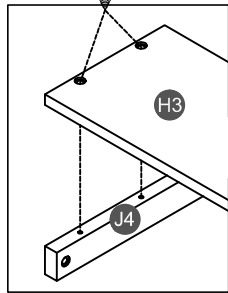
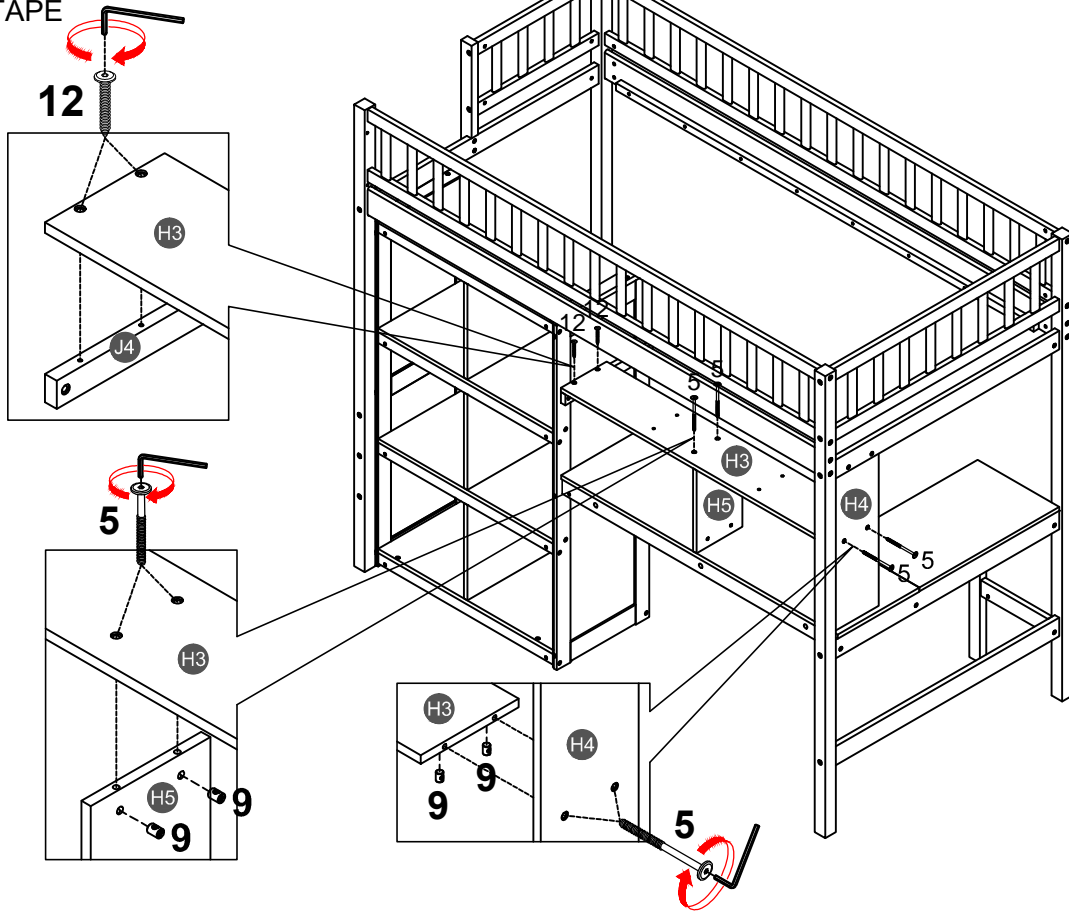

5	
4PCS	
9	
4PCS	
12	
2PCS	

STEP 27:

ÉTAPE

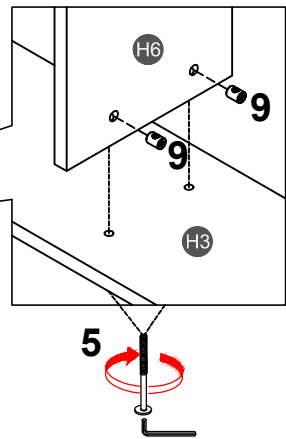
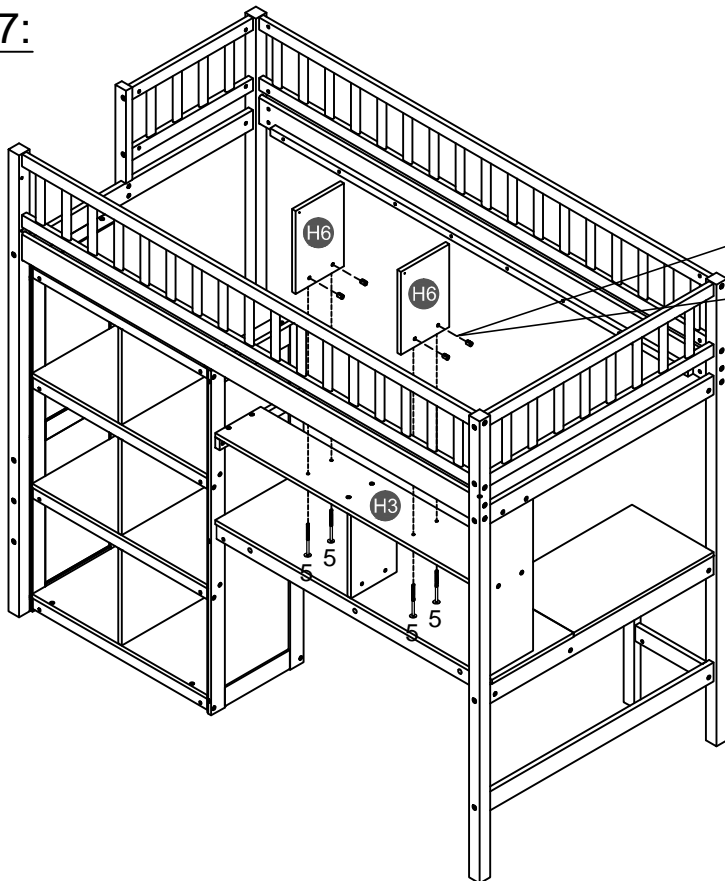



5		9	
4PCS		4PCS	

STEP 28:

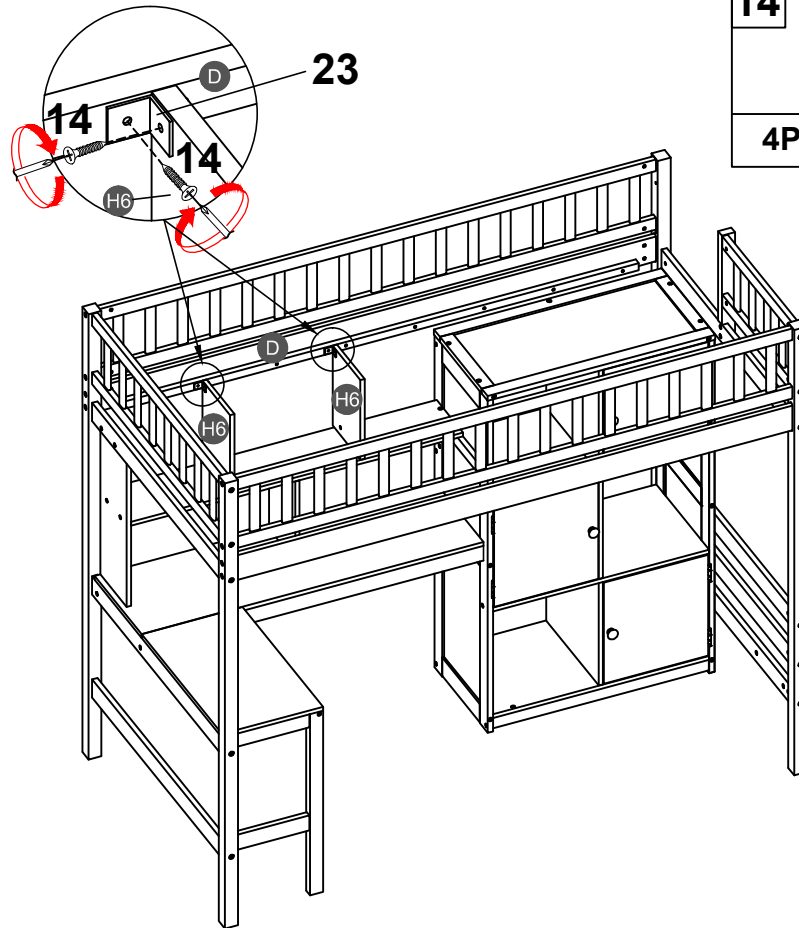
ÉTAPE



14	23
	
4PCS	2PCS

STEP 29:

ÉTAPE

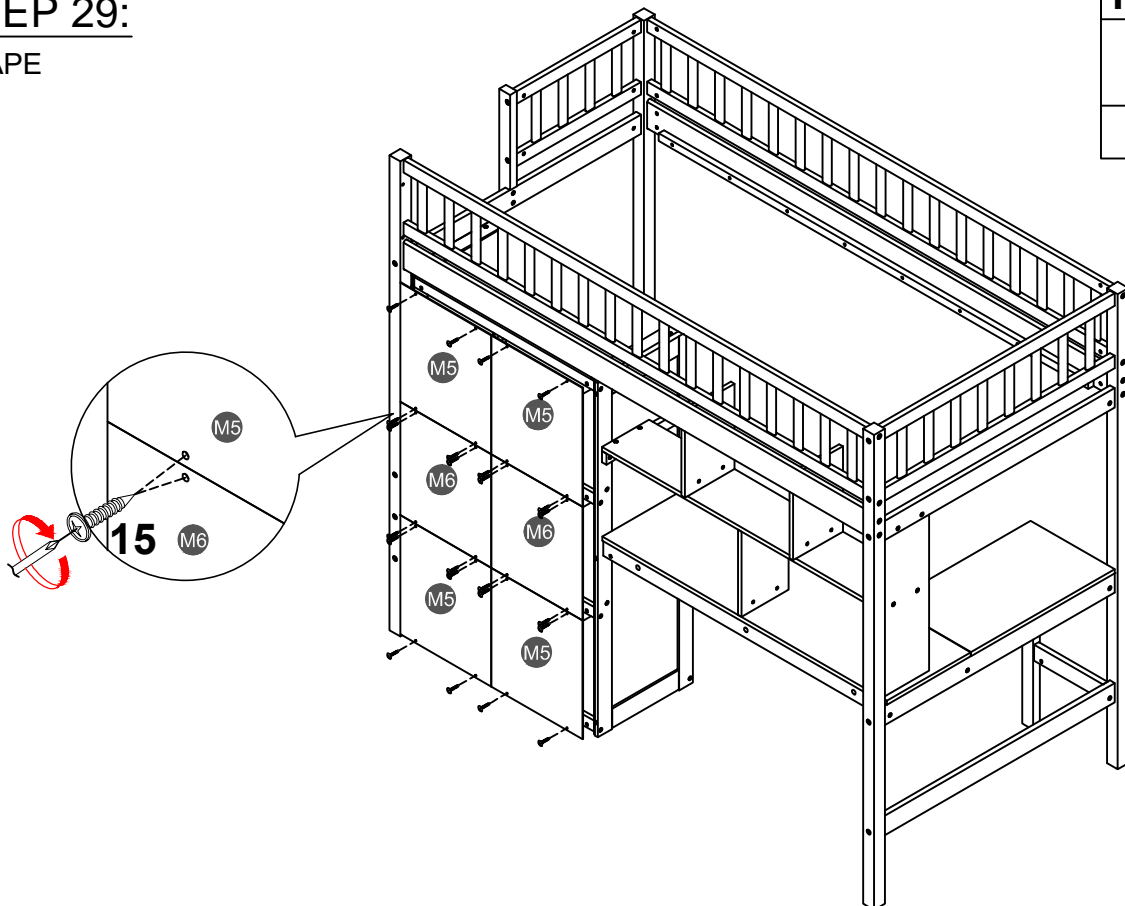

15

24PCS

Detail View

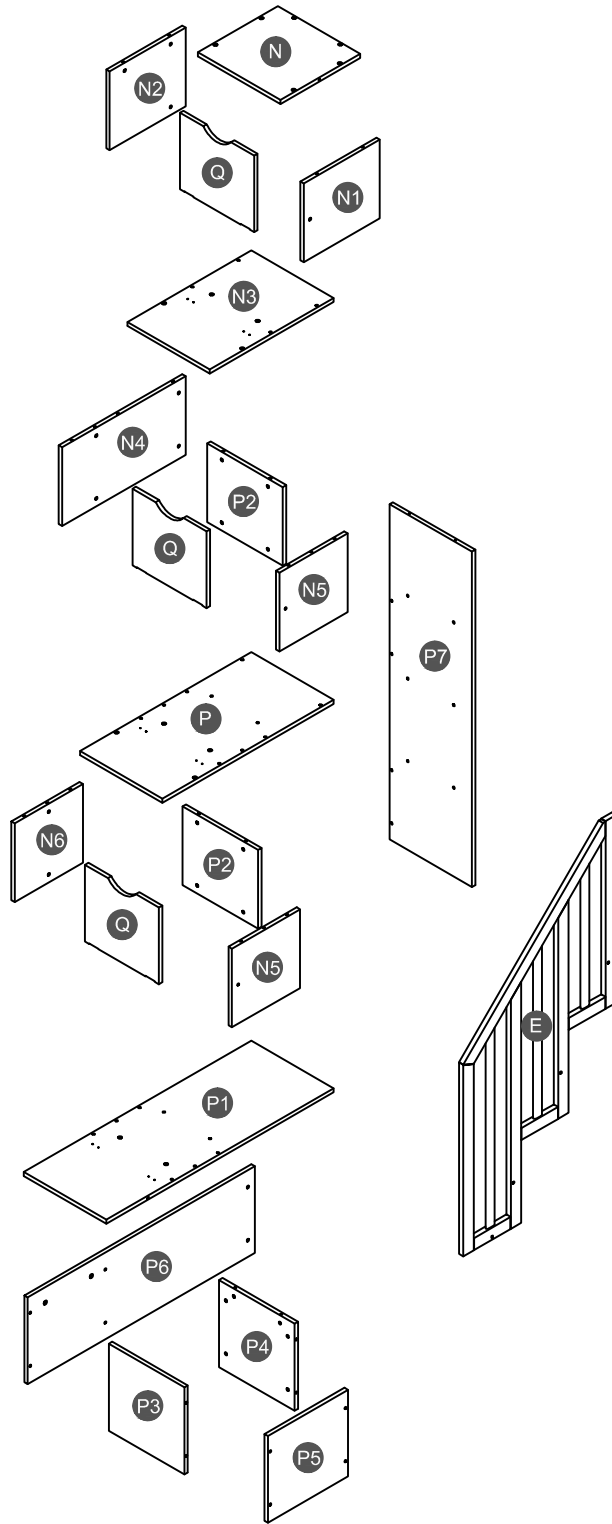
Vue Détaillée



STEP 30:

ÉTAPE

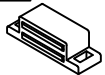
14	18
	
2PCS	1PC

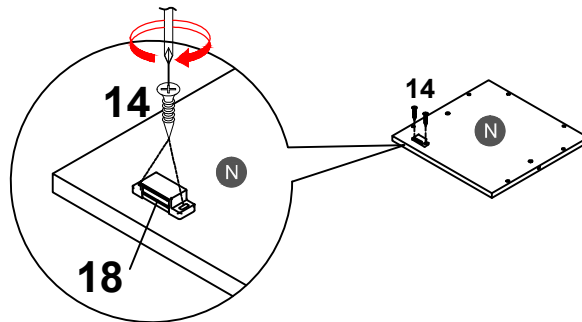

STEP 31:

ÉTAPE

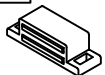
14	18
	
2PCS	1PC

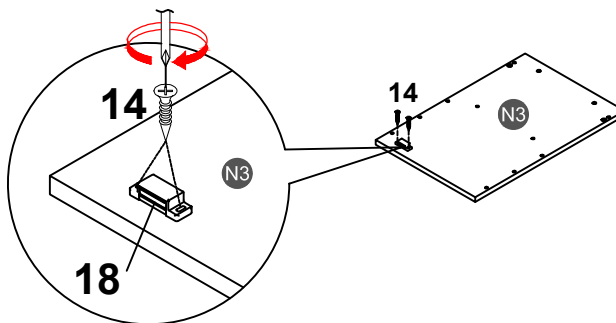

STEP 32:

ÉTAPE

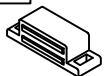

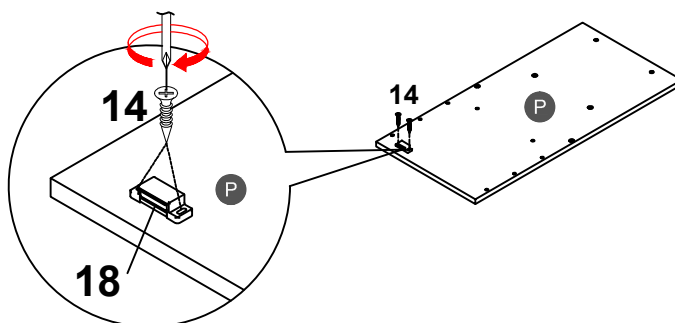
14	18
	
2PCS	1PC

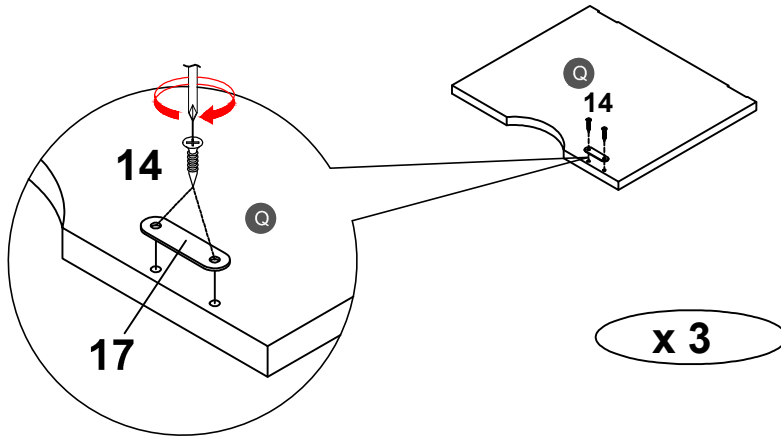

STEP 33:

ÉTAPE





14		17	
6PCS		3PCS	

STEP 34:

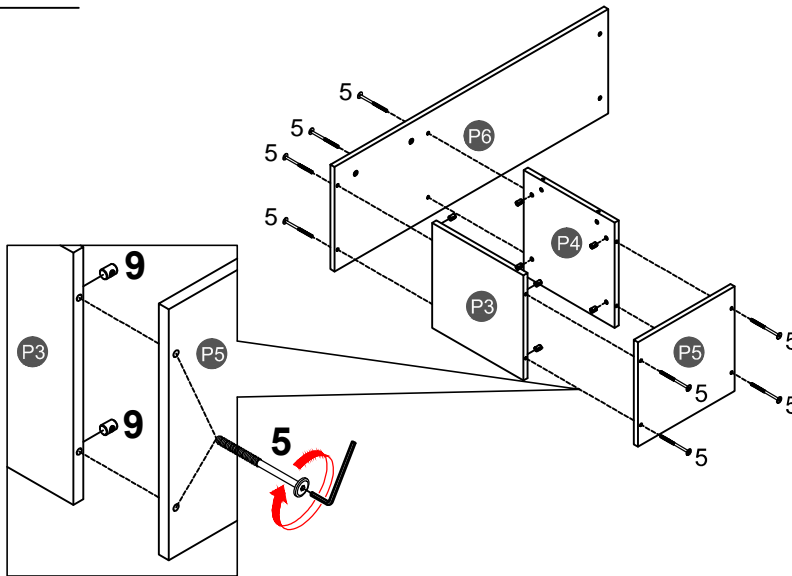
ÉTAPE





5		9	
8PCS		8PCS	

STEP 35:

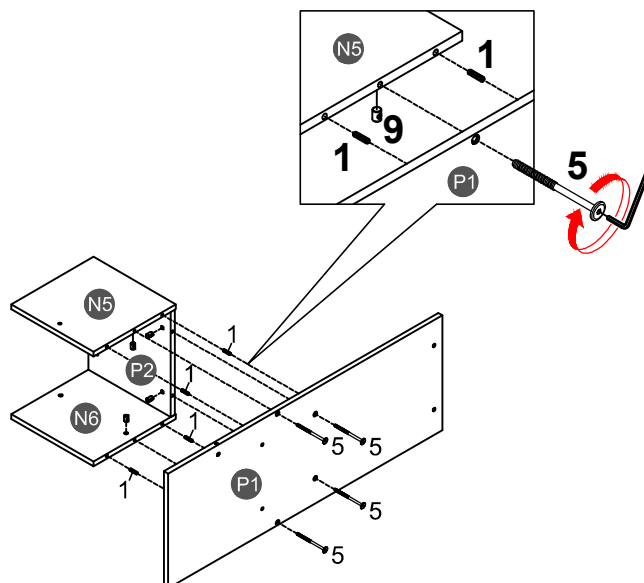
ÉTAPE





1	
4PCS	
5	
4PCS	
9	
4PCS	

STEP 36:

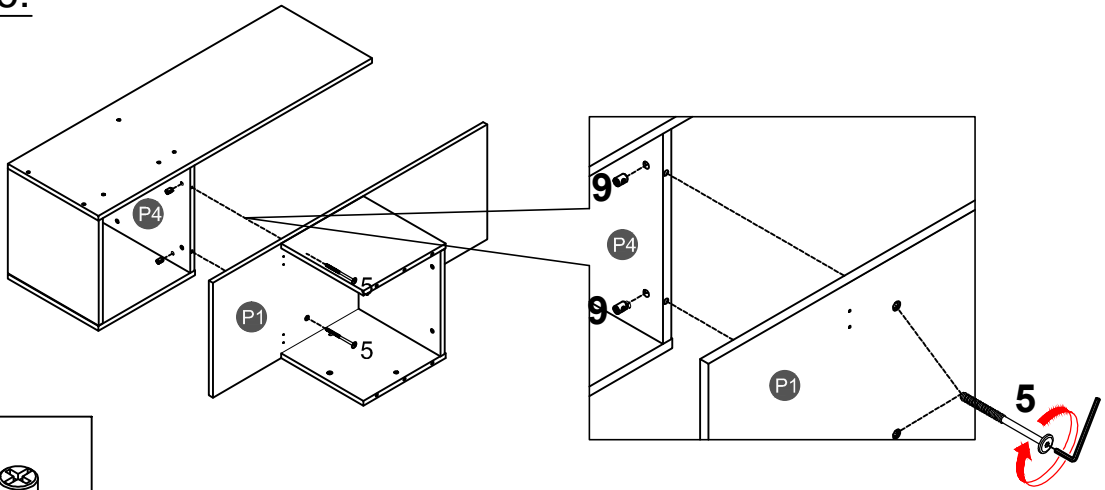
ÉTAPE





5		9	
2PCS		2PCS	

STEP 37:

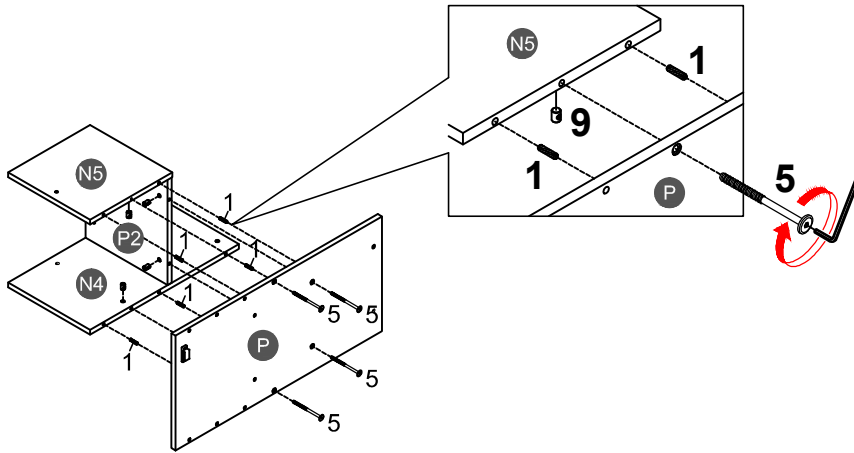
ÉTAPE





1	
5PCS	
5	
4PCS	
9	
4PCS	

STEP 38:

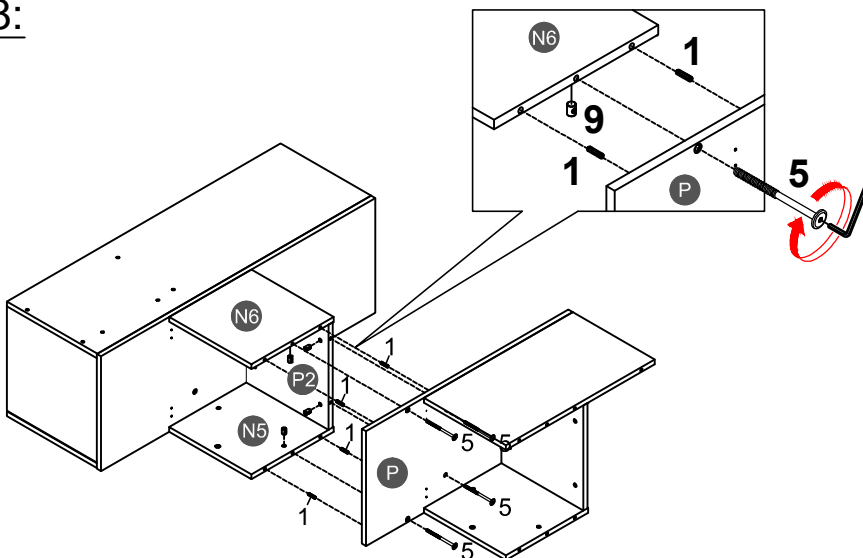

ÉTAPE



1	
4PCS	
5	
4PCS	
9	
4PCS	

STEP 39:

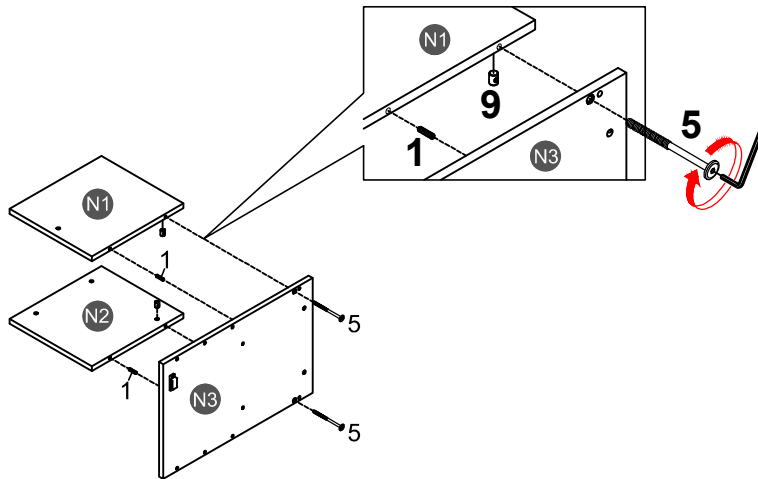

ÉTAPE

1		5		9	
2PCS		2PCS		2PCS	



STEP 40:

ÉTAPE

5		9	
4PCS		4PCS	

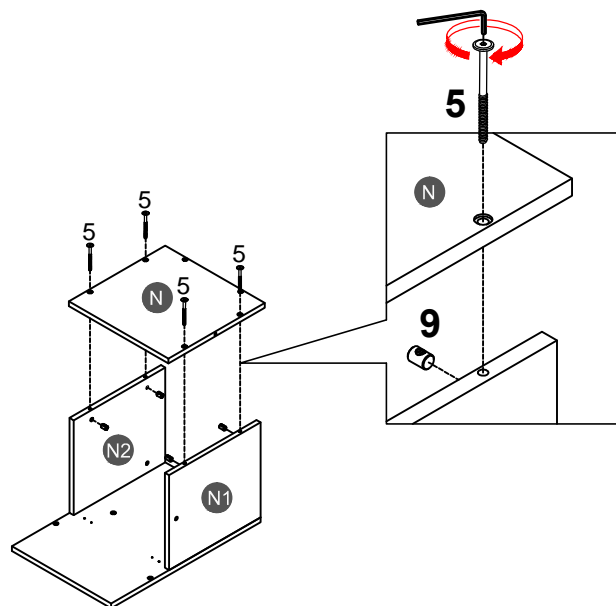

STEP 41:

ÉTAPE

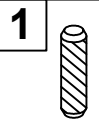
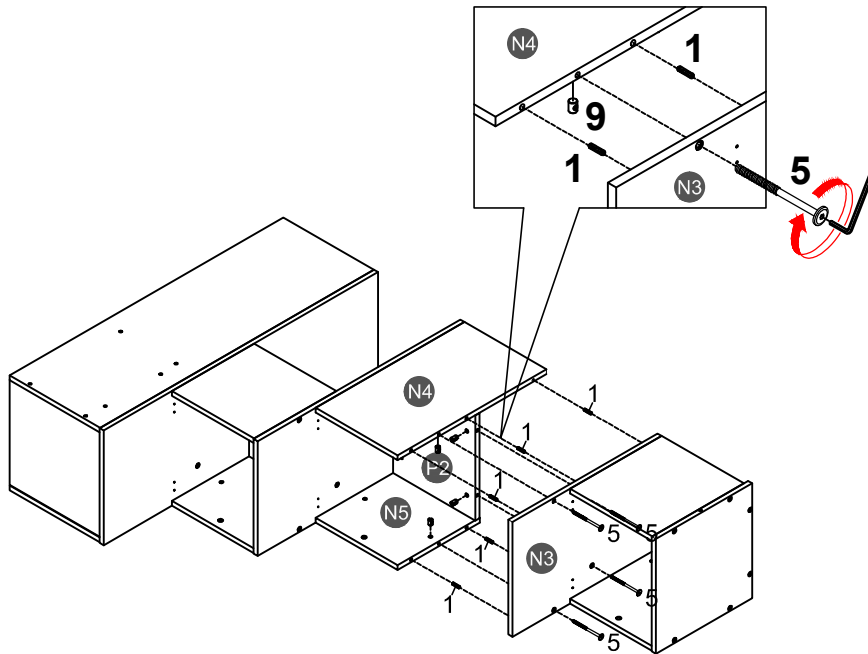

5PCS

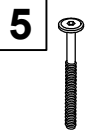

4PCS



4PCS

STEP 42:

ÉTAPE

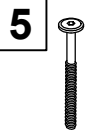
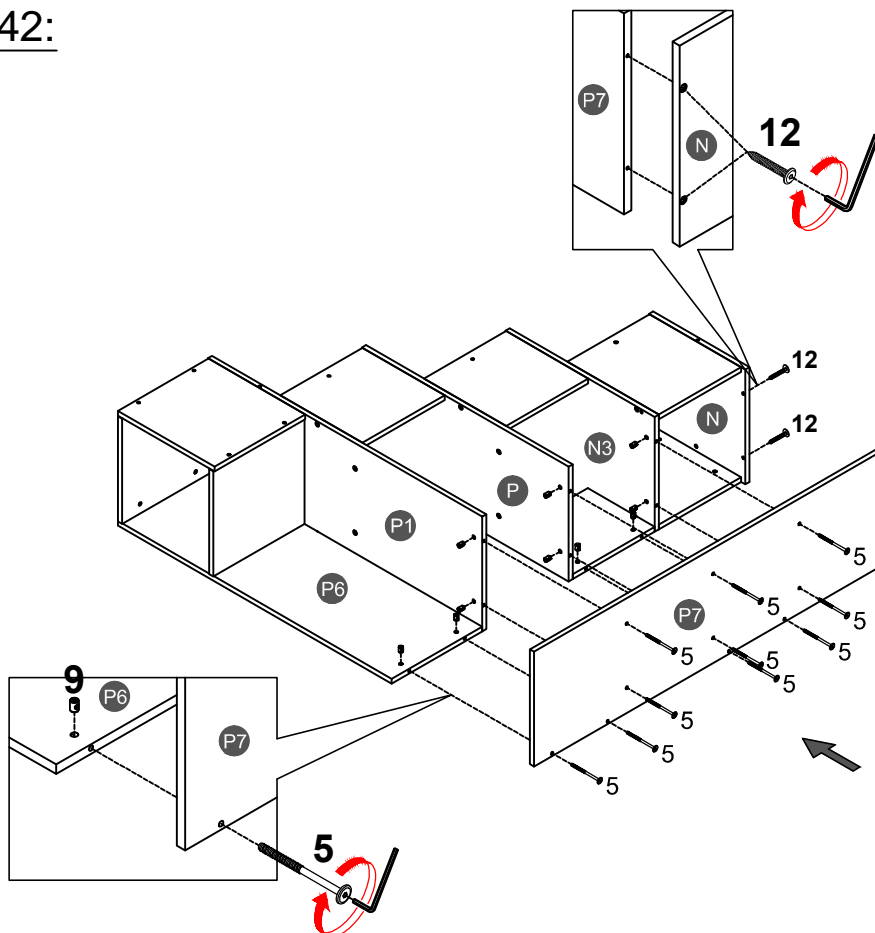

10PCS



10PCS



2PCS

STEP 43:

ÉTAPE

5



2PCS

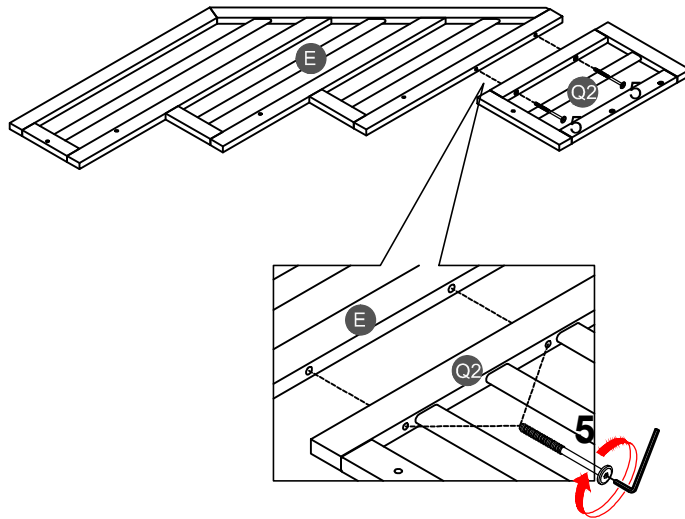

STEP 44:

ÉTAPE

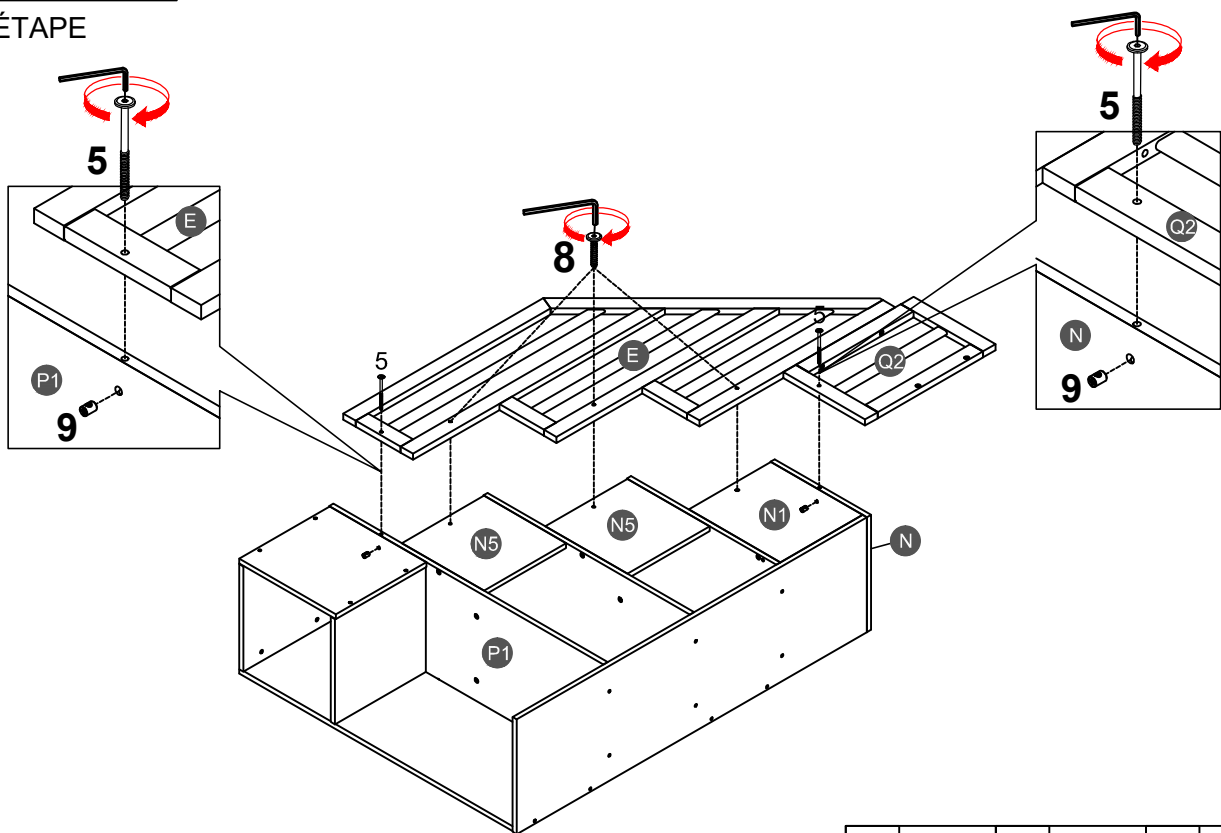

5



2PCS

8



3PCS

9



2PCS

STEP 45:

ÉTAPE

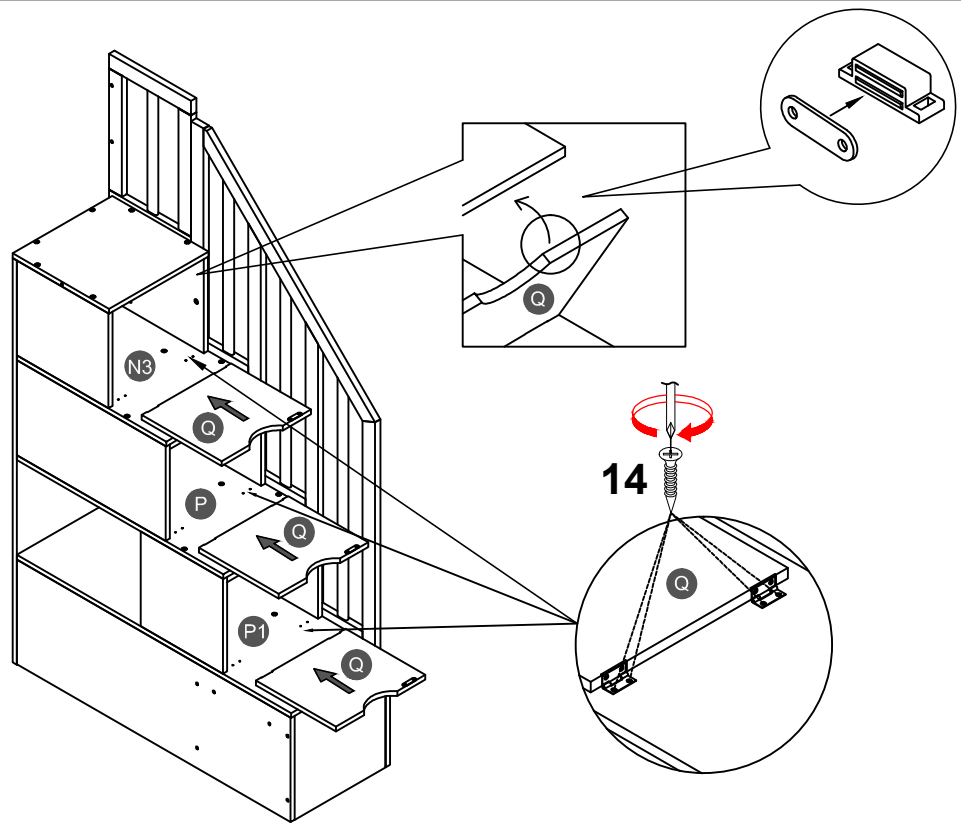

14



12PCS

STEP 46:

ÉTAPE

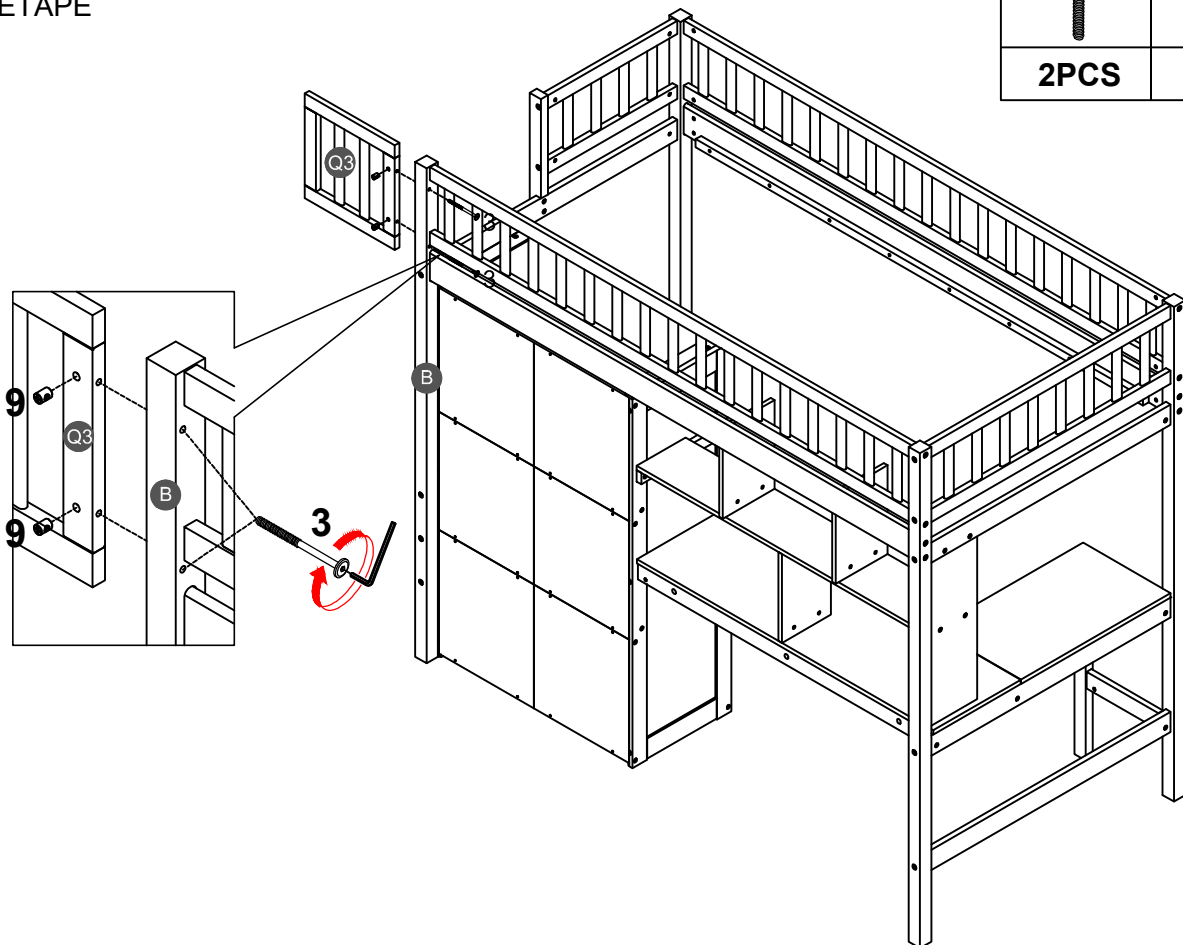

3



2PCS

9



2PCS

STEP 48:

ÉTAPE

13



28PCS

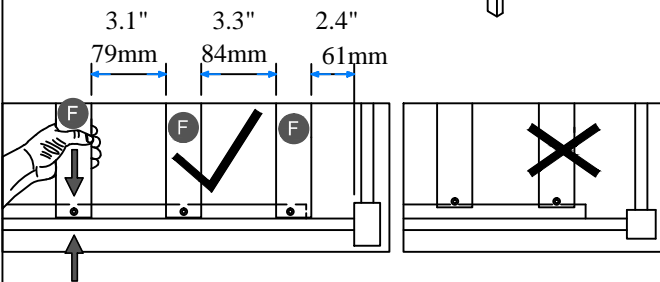
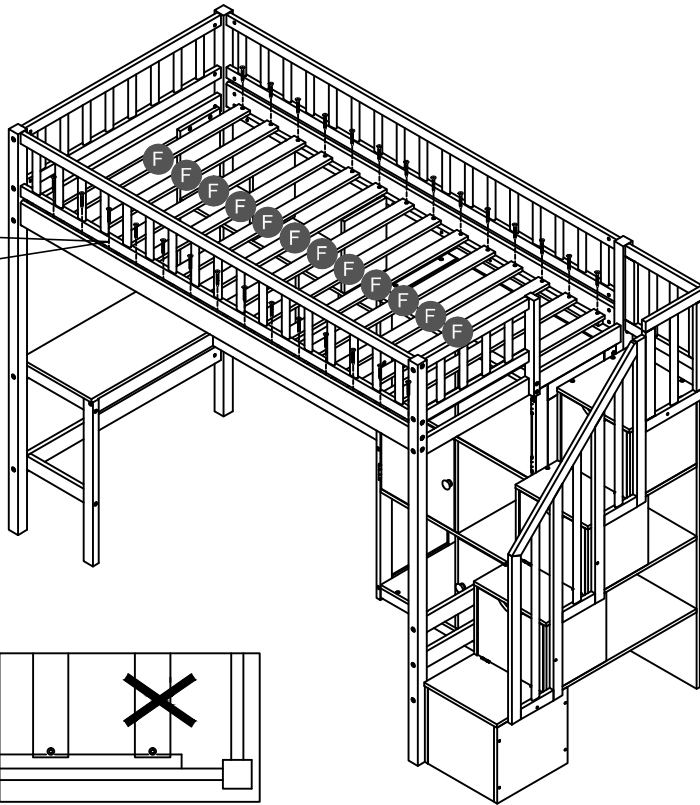
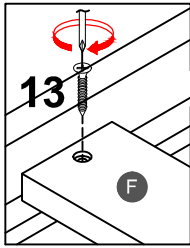

NOTE: Please make sure the bed slats close to the side rail before locking the screws to avoid breakage. This step is required for both the left and right sides. Moreover, please do not lock the screws of the bed slats at the outermost edge to avoid damaging.



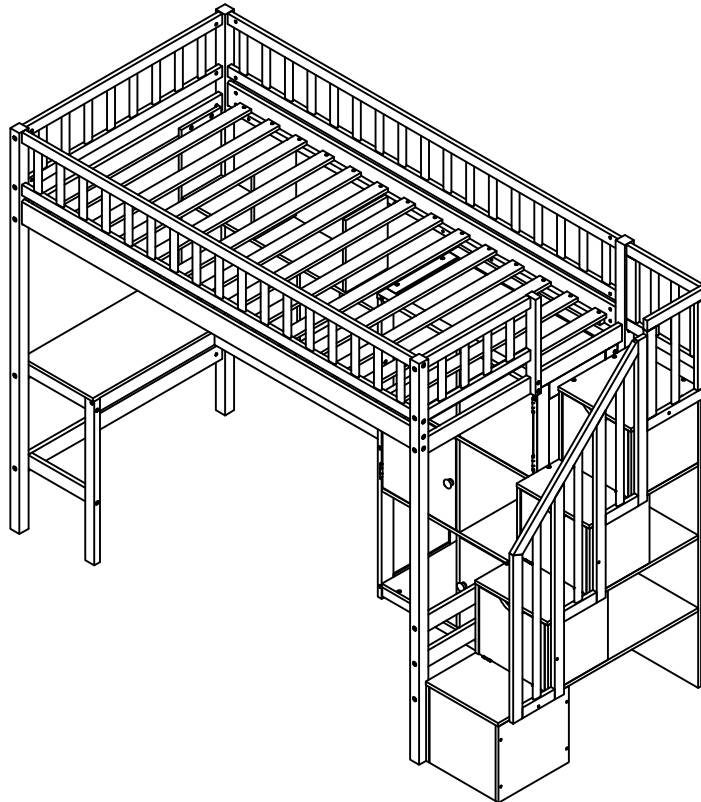

Remarque: Assurez-vous Les lattes du lit fermer du rail latéral avant de verrouiller les vis pour éviter la casse. Cette étape est requise pour tous les deux côtés gauche et droit. De plus, ne verrouillez pas les vis des lattes de lit sur le bord le plus extérieur pour éviter d'endommager.

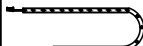

Make sure to tighten all the screws of the bed.

Assurez-vous de serrer toutes les vis des de lit.

STEP 49:
ÉTAPE

15 	24 	25 	26 	27 
1PC	1PC	1PC	1PC	1PC

