

ASSEMBLY INSTRUCTIONS

COD03 Storage Cabinet

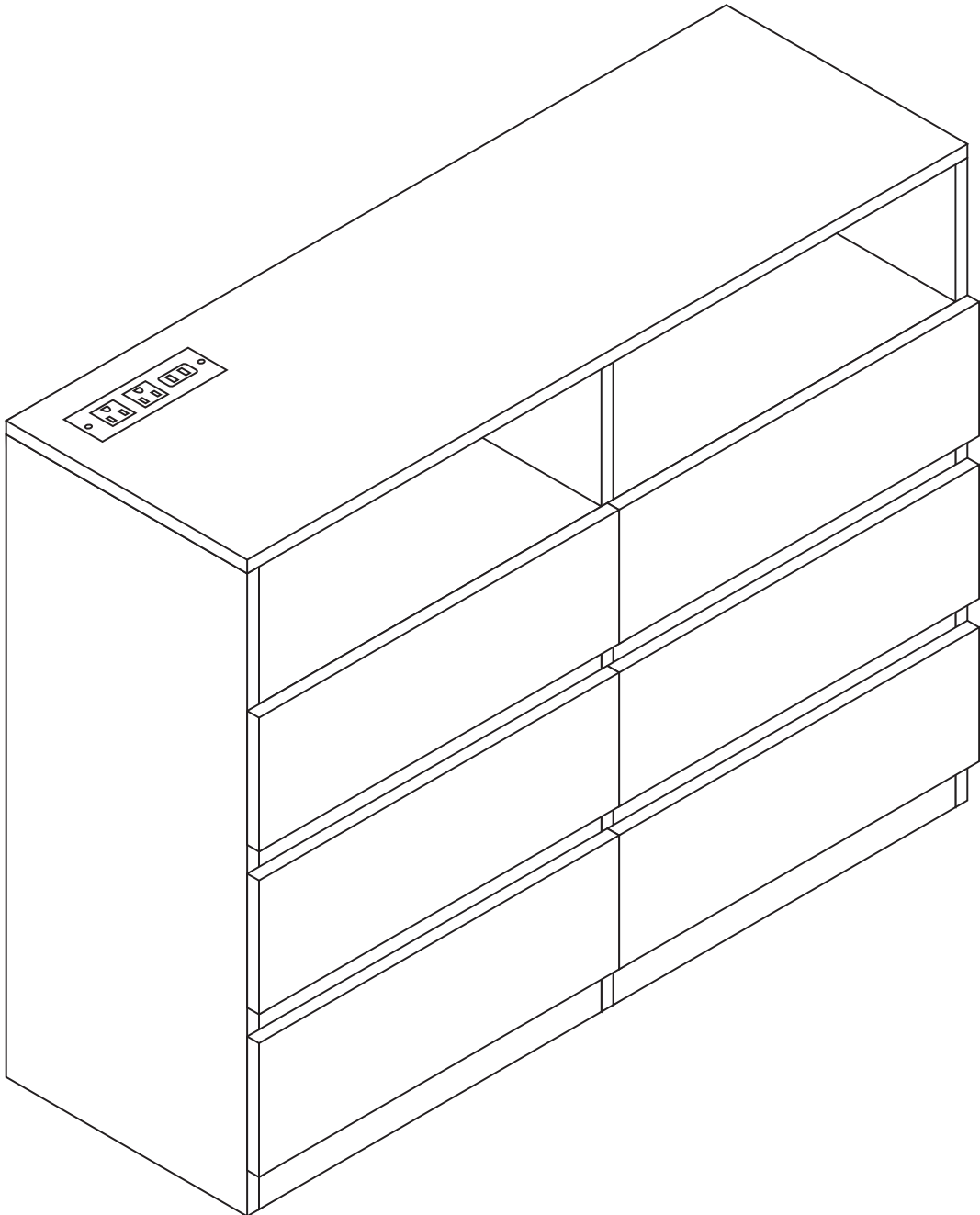

Thank you for purchasing our product!

Please refer and use this assembly instruction to assemble the product.

Contact our customer service department in case there are any missing or damage parts or hardware. Please also tell us your "Order ID", We will solve for you as soon as possible.

EMAIL: customerservice@hkfoam.com

ASSEMBLY PREPARATION:

1. Remove all packaging materials, staples and packing straps from the carton.
2. Refer to Parts List and Hardware List and ensure they are correct before assembly. Contact customer service for missing parts.
3. Place all wooden parts on a clean, flat and soft surface (e.g. carpet or rug) to prevent parts from getting scratched.

SAFETY PRECAUTION:

1. Keep all hardware parts out of reach of children.
2. Dispose plastic packaging material immediately to avoid any risk of suffocation to children and animals..

TIPS FOR ASSEMBLY:

1. Allow ample room for assembly and in close proximity to where product will be placed.
2. Assemble the product on a surface that does not scratch or damage the exterior gloss and finish of the furniture.
3. Identify all of the parts, hardware and quantities required for each step.
4. During assembly, do not over-tighten any fittings as this may cause damage.
5. DO NOT USE POWER TOOLS TO ASSEMBLE THIS PRODUCT.
6. Always place the product on a flat, level surface.
7. Do not sit or stand on the partially assembled product; only use the product for which it is intended.

CARE AND MAINTENANCE:

- Use a slightly damp cloth to clean the product. Do not use bleach or abrasive cleaning material.
- Check all the fittings periodically and re-tighten as necessary. Do not use the product if any of the parts is damaged or broken.
- Never allow any kind of liquid to remain on your furniture. Absorption can cause wood to warp or delaminate.
- Do not place hot items (e.g. hot drinks) directly onto the wood surface.





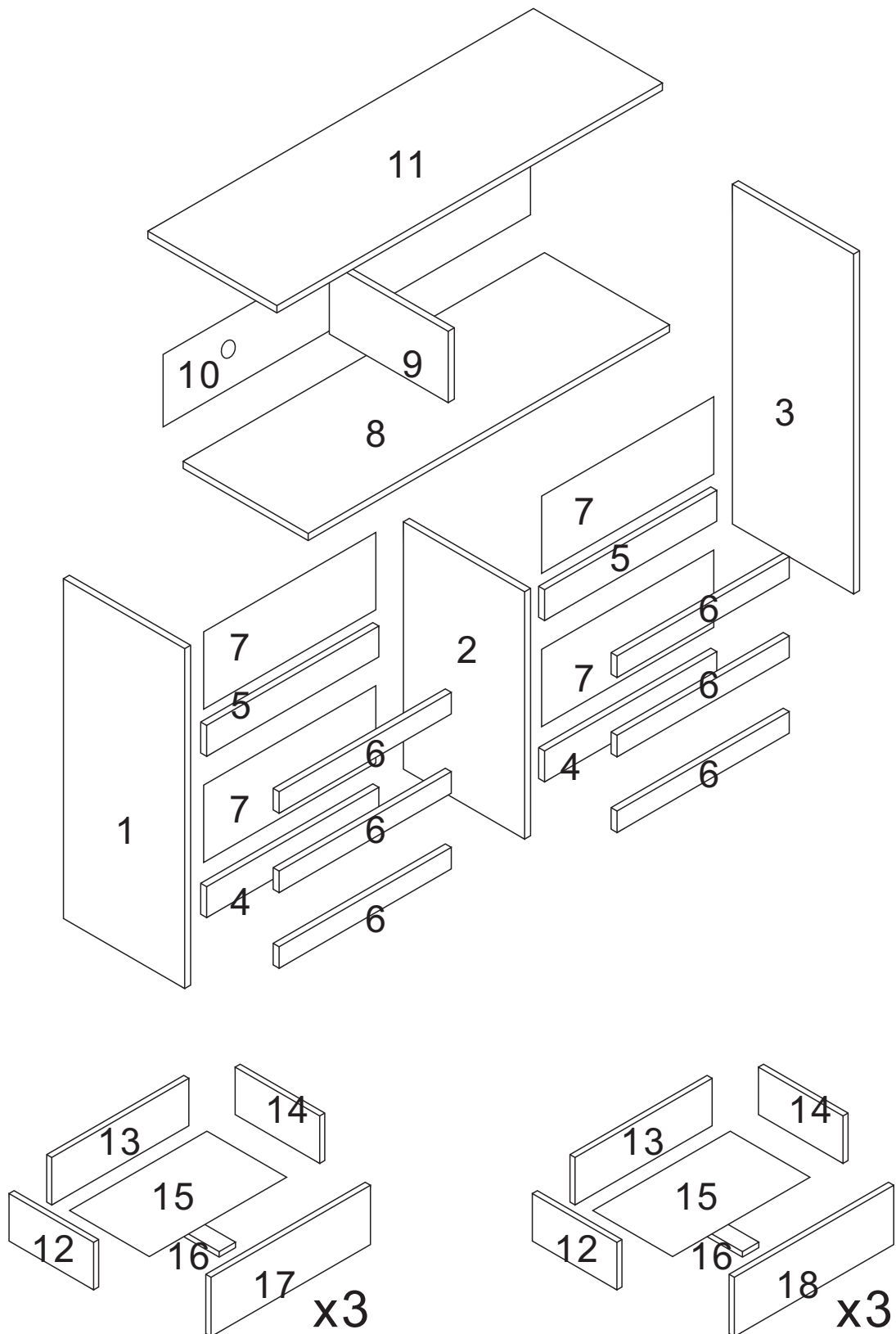







Part List

Please check if all the pieces listed bellow are received

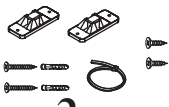

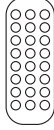
Hardware List

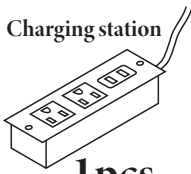
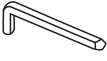
Please check if all the piece listed bellow are received

<p>A Cam bolt</p>  <p>124pcs</p>	<p>B Cam lock</p>  <p>124pcs</p>	<p>C Screw</p>  <p>58pcs</p>	<p>D Long screws</p>  <p>2pcs</p>	<p>E Short slide rail</p>   <p>18pc</p>
<p>F Plastic wedge</p>  <p>10pcs</p>	<p>G Anti-dumping accessories</p>  <p>2pcs</p>	<p>H Light strip</p>  <p>1pcs</p>	<p>H Remote control</p>  <p>1pcs</p>	<p>H Plastic clips</p>  <p>2tps</p>
<p>I Charging station</p>  <p>1pcs</p>	<p>J Hexagon screwdriver</p>  <p>1pcs</p>	<p>K Screwdriver</p>  <p>1pcs</p>		

**ASSEMBLY
REQUIREMENTS**

**3Hours
Assembly Time
(Approximate)**

2 -Person Assembly

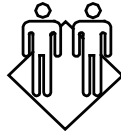

Tools Required (Not Provided):

Mark Pencil

Power Drill

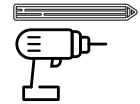

CAM LOCK SYSTEM OPERATION

NOTE: When inserting the Cam Lock, make sure that the Open End of the Cam Lock faces the Cam Screw Entry. The Dowel will be inserted in the hole NEXT to the Cam Lock/Cam Screw Hole.

NOTE: The Cam Lock is backwards in this illustration. The Cam Screw can not connect to the Cam Lock because the Dowel is in the incorrect hole.

NOTE: To tighten, turn the Cam Lock CLOCKWISE until the arrow point AWAY from the connected Panel.

NOTE: DO NOT USE AN AUTOMATIC SCREWDRIVER TO TIGHTEN CAM LOCKS, DO NOT OVER-TIGHTEN.

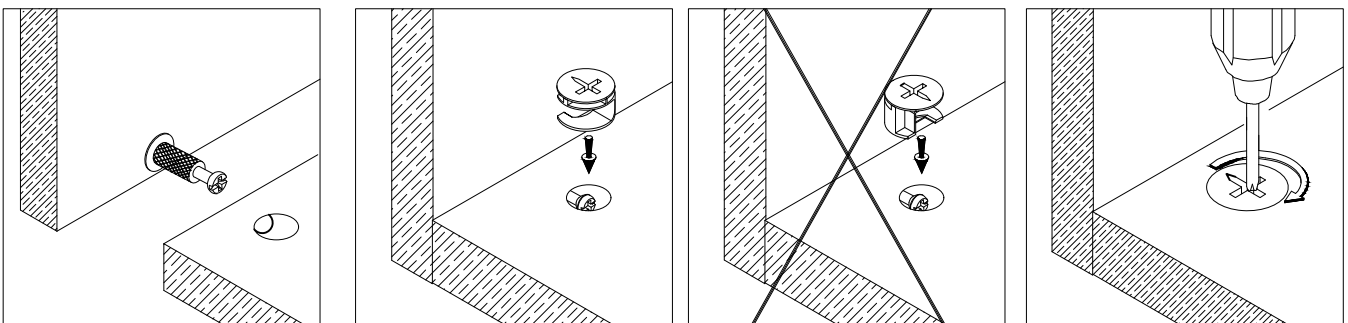
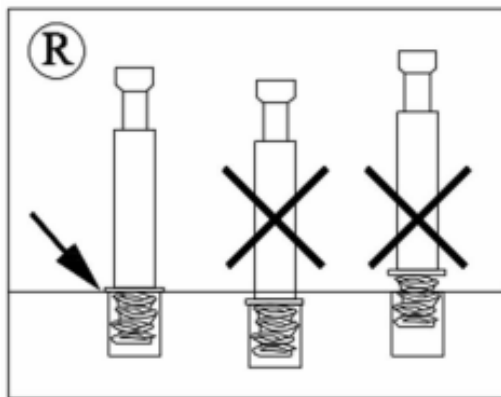
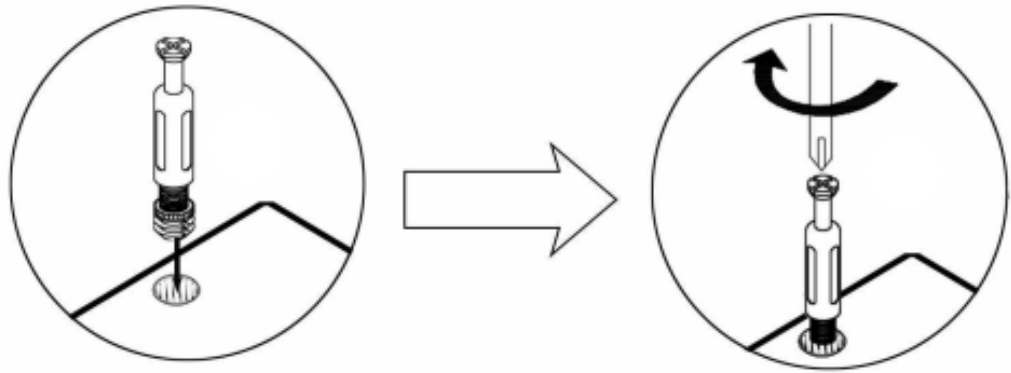

Before installing the drawer rail, you need to separate the E1 and E2 first.

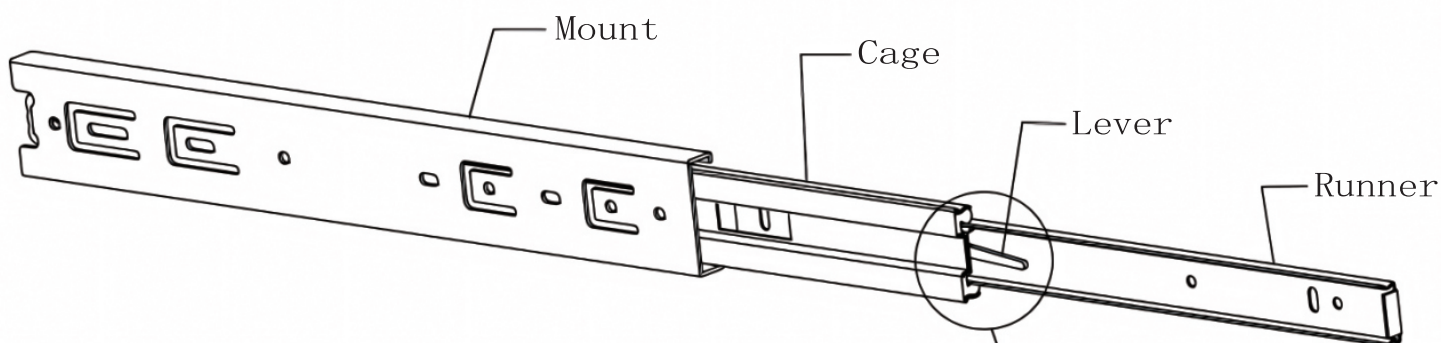

STEP 1: Extend Slider

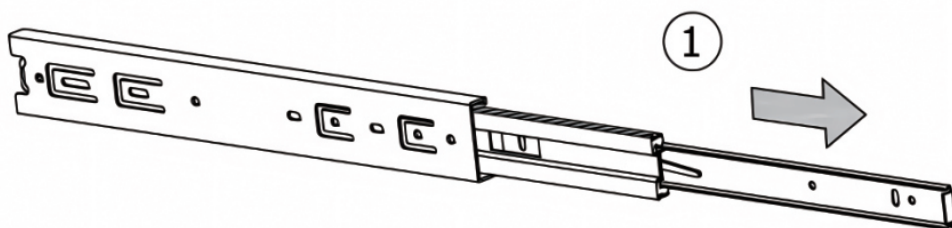

STEP 2: Push Lever Up

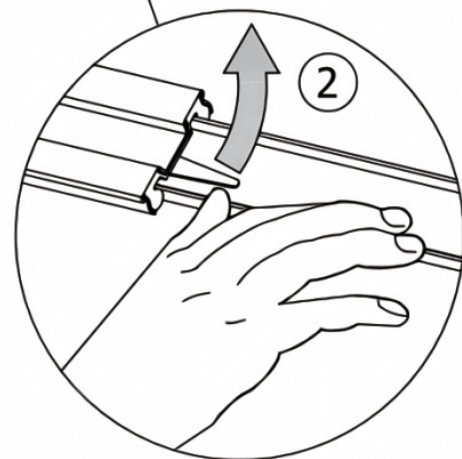

STEP 3: Remove Runner

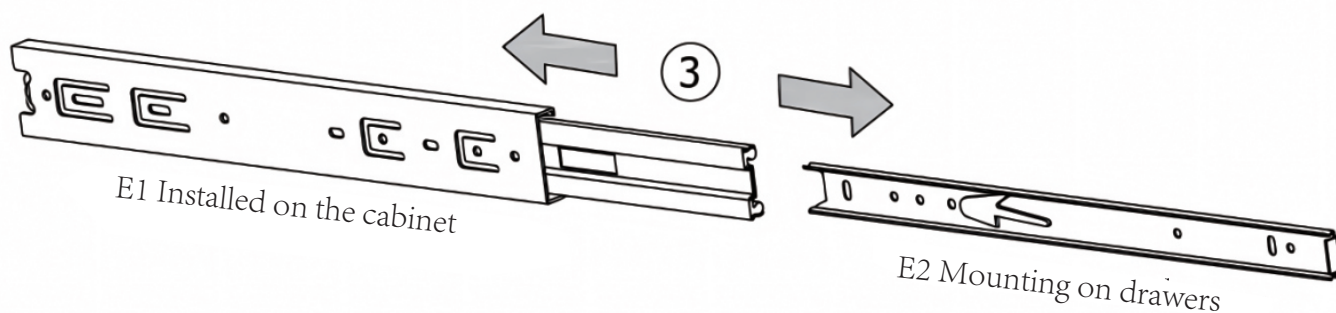



Step 1

I. Use screws (C) to secure the slide rail (E1) to the panel (1,3), and tighten them with a screwdriver.

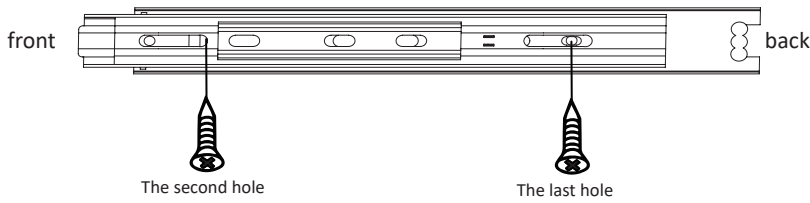
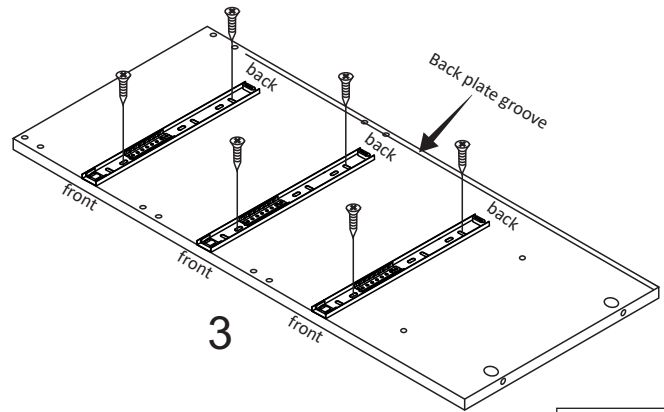
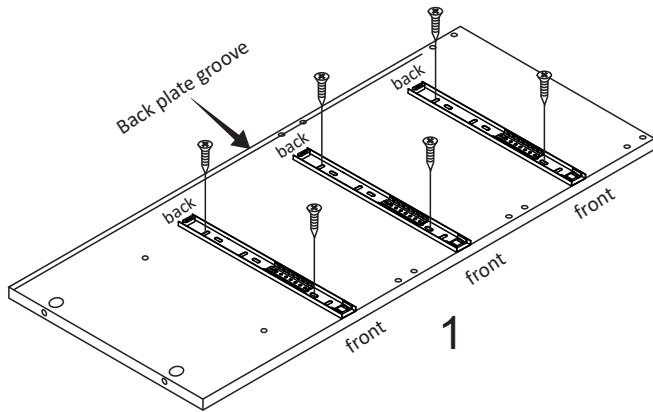
Note: For the correct orientation of slide rail (E1), please refer to the image.(front and back)



C	X12
	
E1	X6
	

Step 2

I. Screw in cam-bolt (A) into the designated holes on panel (1,3).

A	X24
	

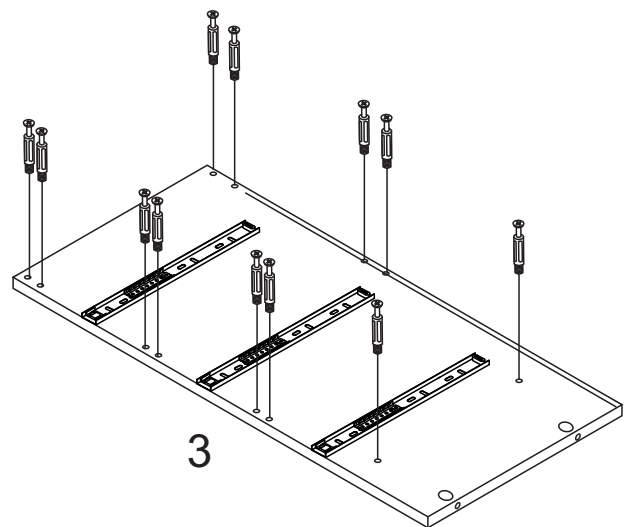
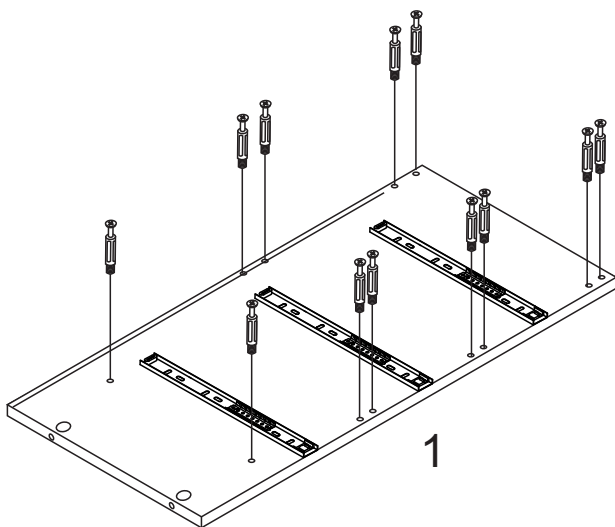

Step 3

I. Use screws (C) to secure the slide rail (E1) to the panel (2), and tighten them with a screwdriver.

Note: For the correct orientation of slide rail (E1), please refer to the image.(front and back)

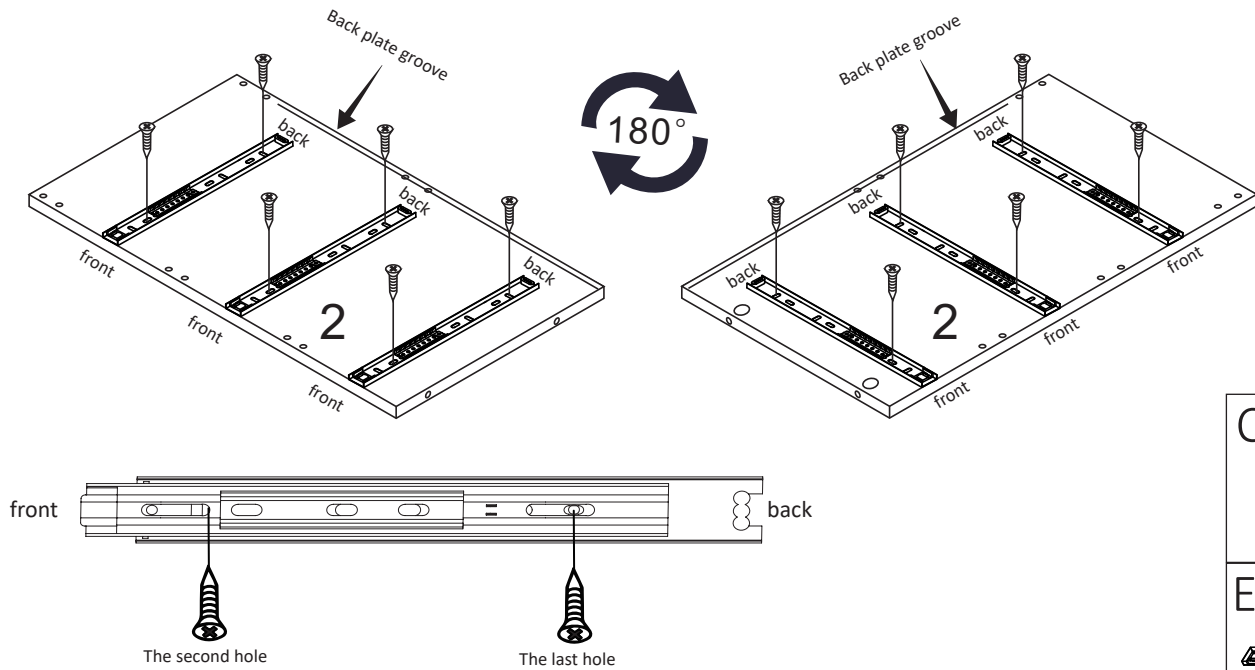

Step 4

I. Screw in cam-bolt (A) into the designated holes on panel (2).

Note: Install cam-bolt (A) on panel 2, please use a manual screwdriver.

It is not recommended to use an electric screwdriver.

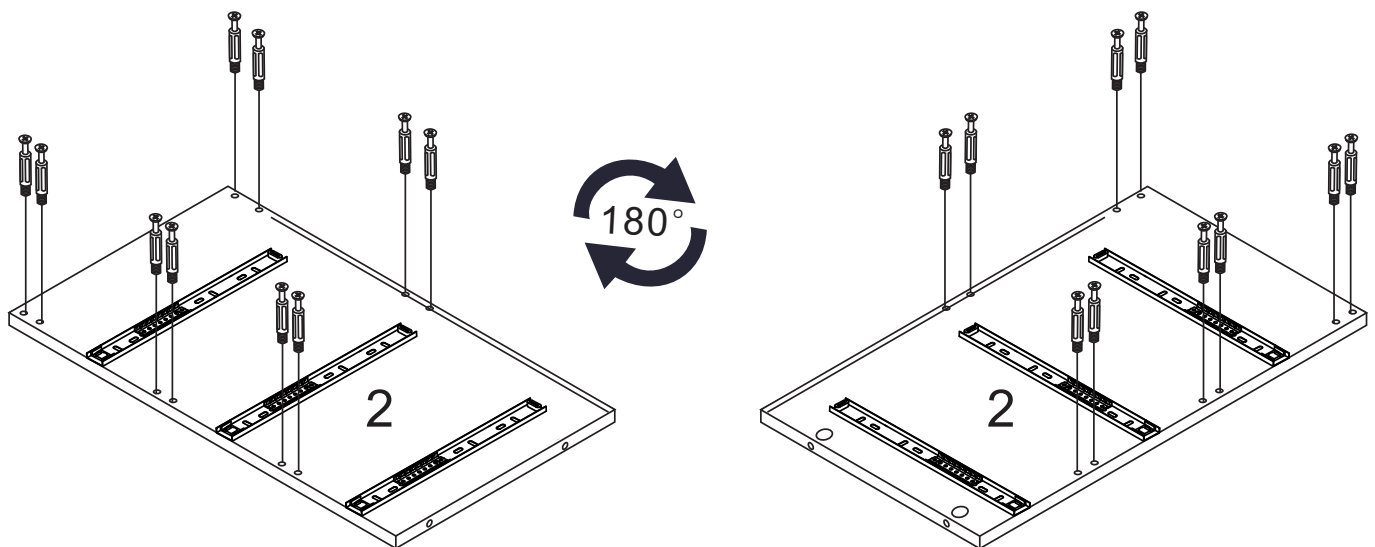
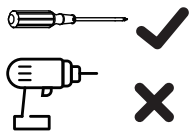

Step 5

I. Attach panel (4,5,6,6,6) to panel (2), insert cam-lock (B) into the panel (4,5,6,6,6), then turn clockwise to lock onto cam-bolt.

Note: The direction of installing cam-lock (B) is shown in the figure

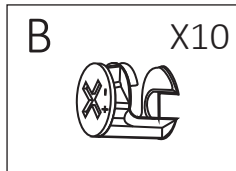
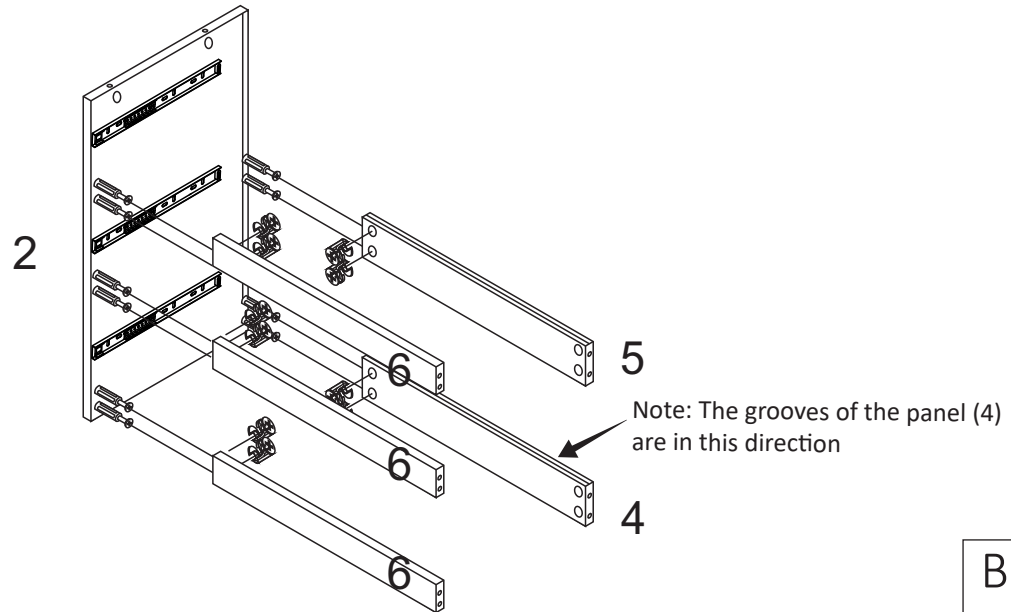

Step 6

I. Attach panel (4,5,6,6,6) to panel (2), insert cam-lock (B) into the panel (4,5,6,6,6), then turn clockwise to lock onto cam-bolt.

Note: The direction of installing cam-lock (B) is shown in the figure

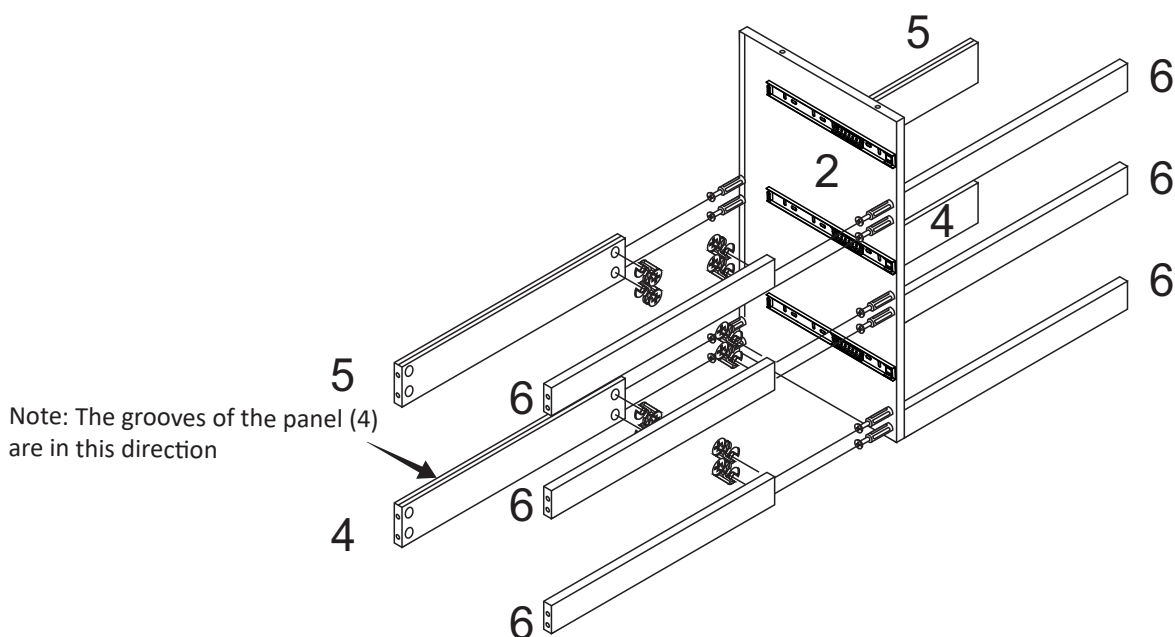
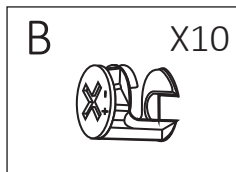

Step 7

I. Attach panel (8) to panel(9), using screw (D) attach panel (8) to panel (9) and tighten them with (J) Hexagon screwdriver.

II. Screw in cam-bolt (A) into the designated holes on panel (8).

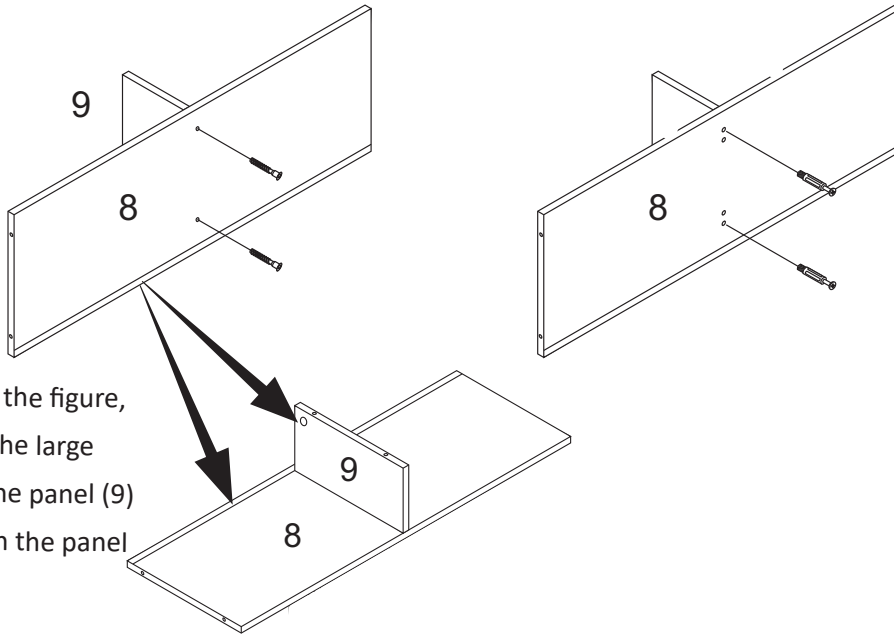

Note: As shown in the figure, the directions of the large circular holes on the panel (9) and the grooves on the panel (8) are consistent.

A	X2
D	X2
J	X1

Step 8

I. Attach the assembled panel (8,9) to panel (2), insert cam-lock (B) into the panel (2), then turn clockwise to lock onto cam-bolt.

Note: The orientation of the large circular hole on panel (9) and the groove on panel (8) is as shown in the figure.

Note: The orientation of the large circular hole on panel (9) and the groove on panel (8) is as shown in the figure.

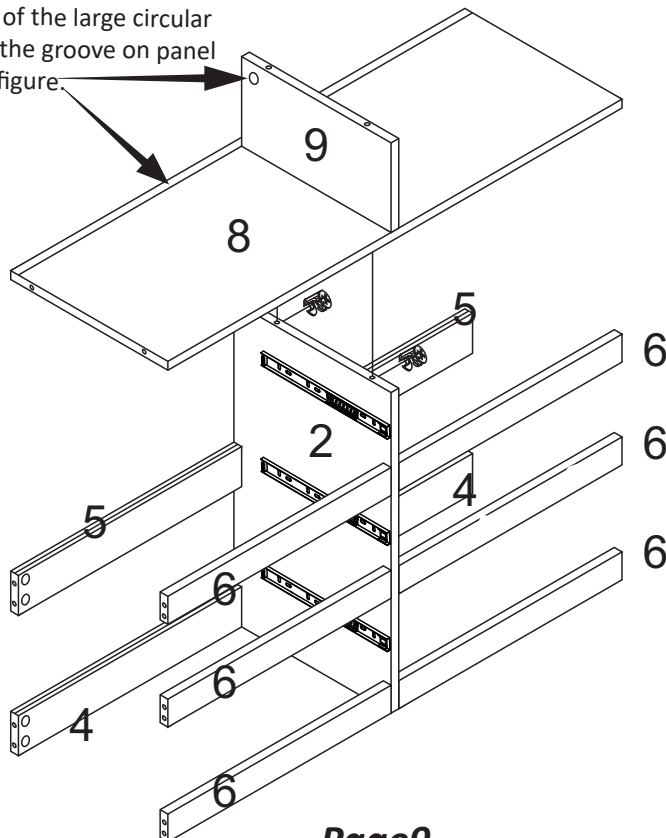

B	X2

Step 9

I. Install panel (7,7) as per diagram and slide them into the grooves until they are fully seated.

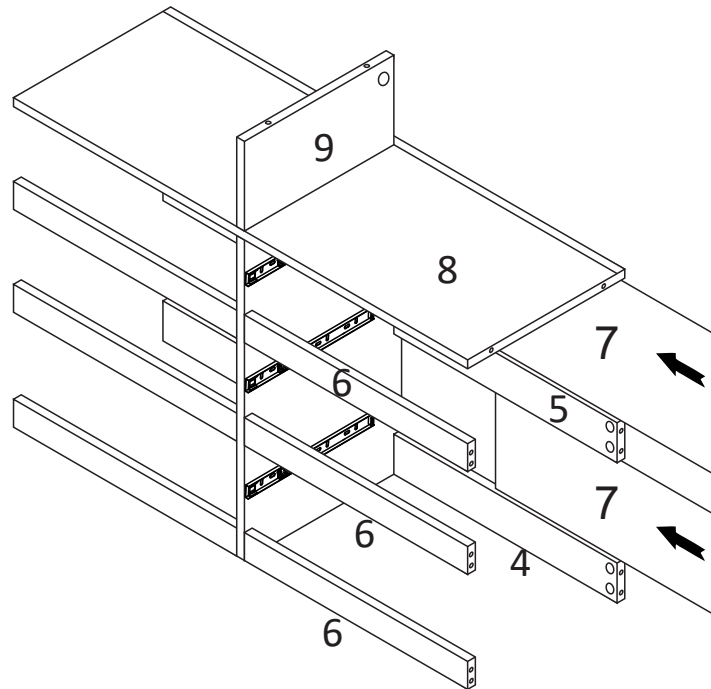

Step 10

I. Attach panel (3) to panel (4,5,6,6,6,8), insert cam-lock (B) into the panel (4,5,6,6,6,8), then turn clockwise to lock onto cam-bolt.

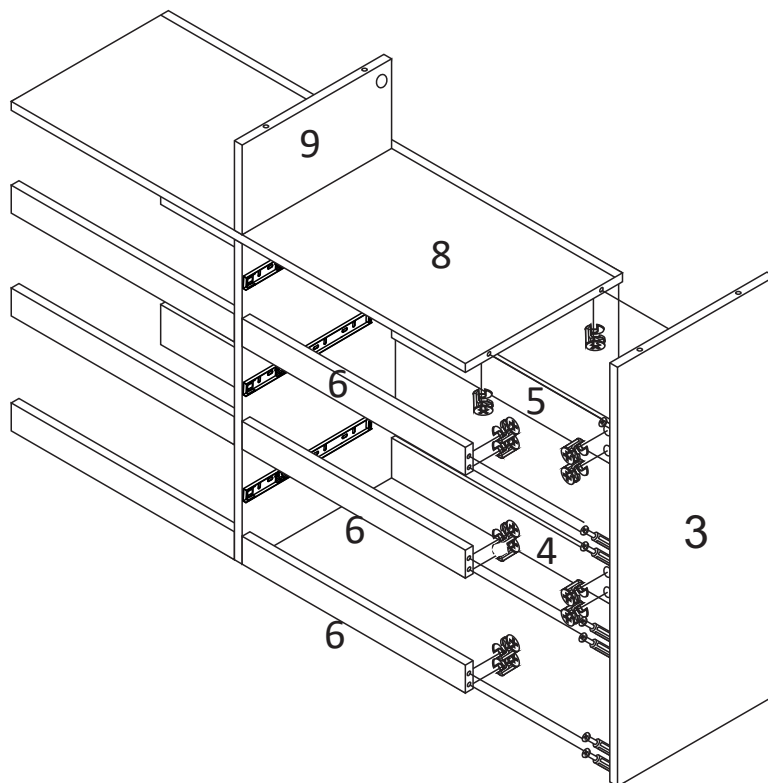
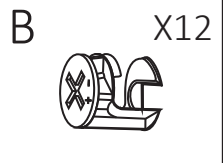

Step 11

I. Install panel (7,7) as per diagram and slide them into the grooves until they are fully seated.

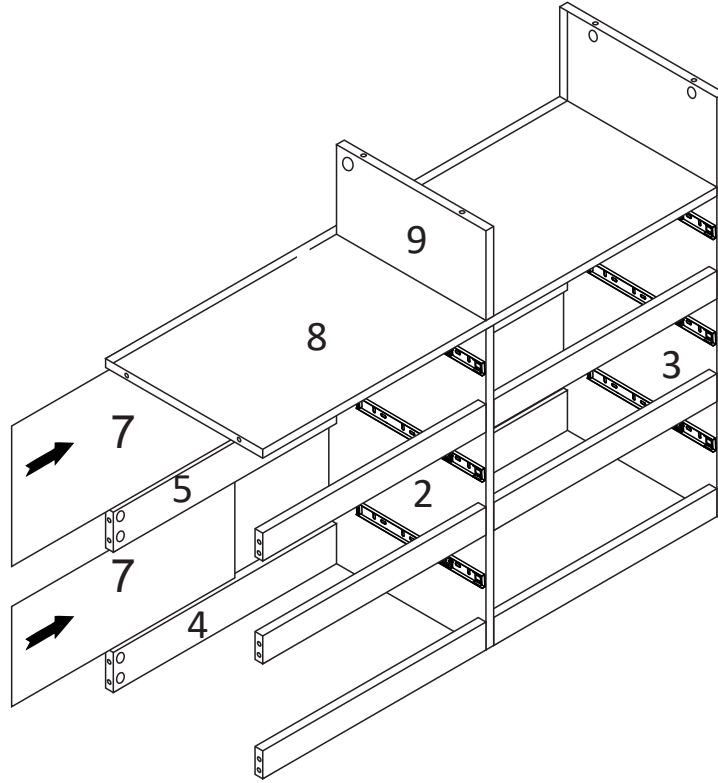

Step 12

I. Attach panel (1) to panel (4,5,6,6,6,8), insert cam-lock (B) into the panel (4,5,6,6,6,8), then turn clockwise to lock onto cam-bolt.

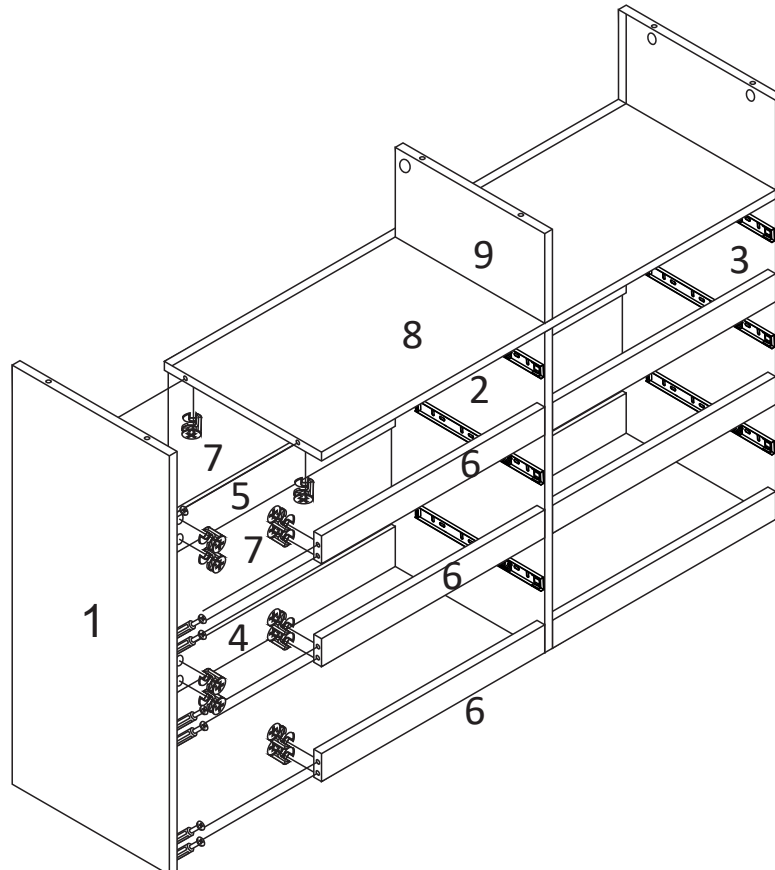

Step 13

I. Install panel (10) as per diagram and slide them into the grooves until they are fully seated.

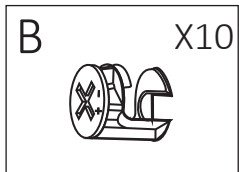
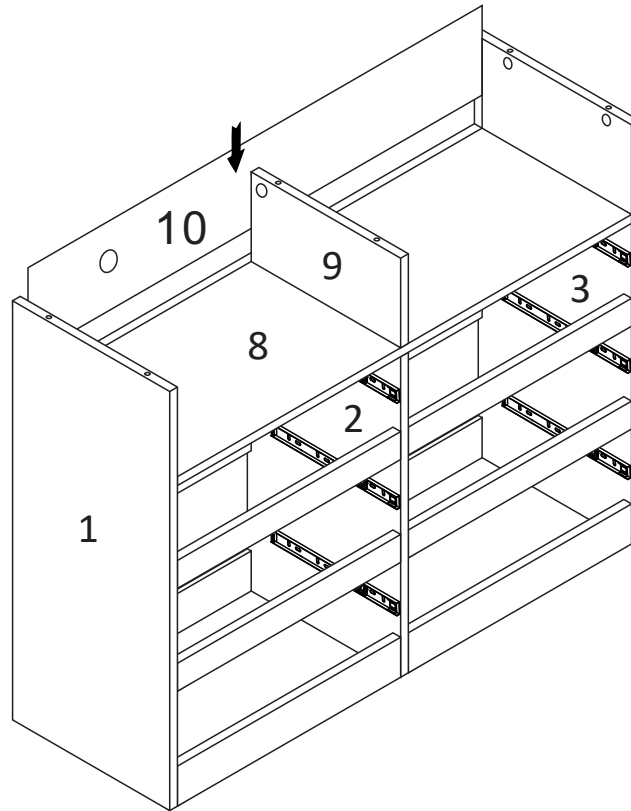

Step 14

I. Screw in cam-bolt (A) into the designated holes on panel (11).

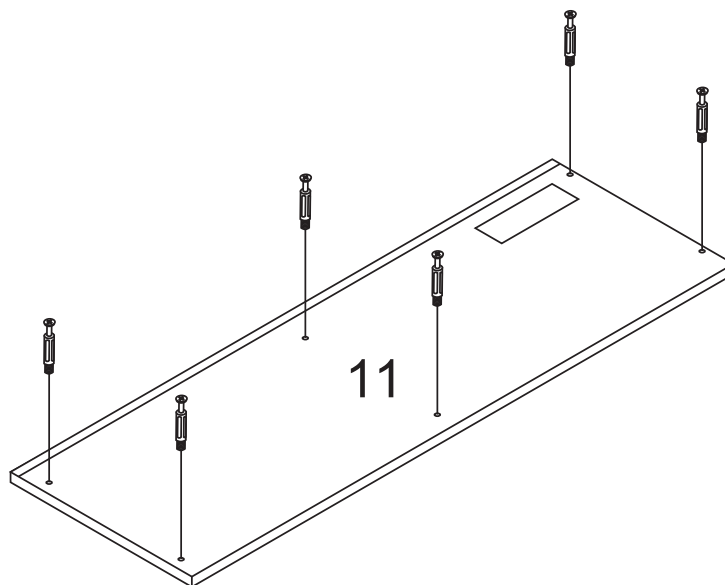
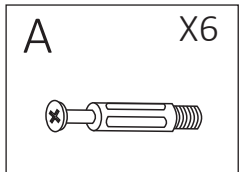

Step 15

I. Attach panel (11) to panel (1,9,3), insert cam-lock (B) into the panel (1,9,3), then turn clockwise to lock onto cam-bolt.

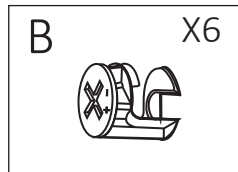
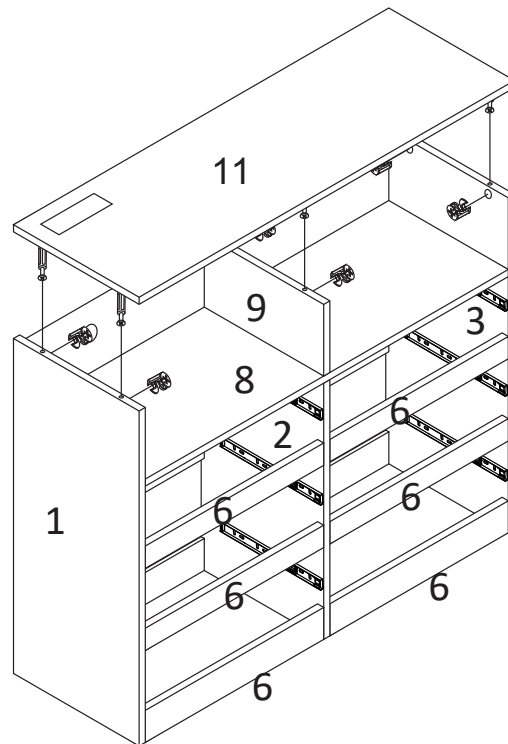

Step 16

I. Fix the charging station (I) to the panel (11) with screws (C).

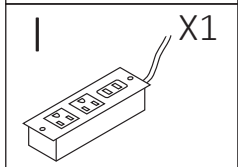
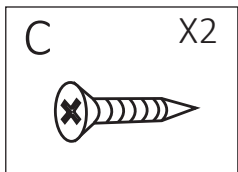
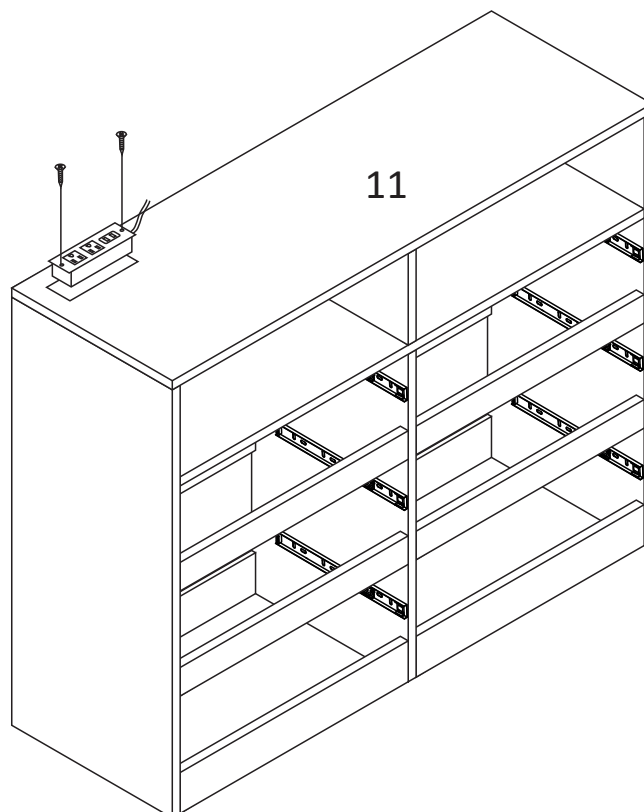

Step 17

I. Stick the light strip (H) onto the panel (11) and pass through the panel (9) .

II. Clip the plastic clip (H) to the light strip (H) and stick it to the panel to make the light strip stick firmly to the panel.

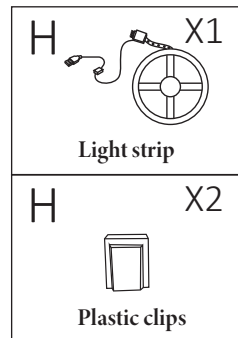
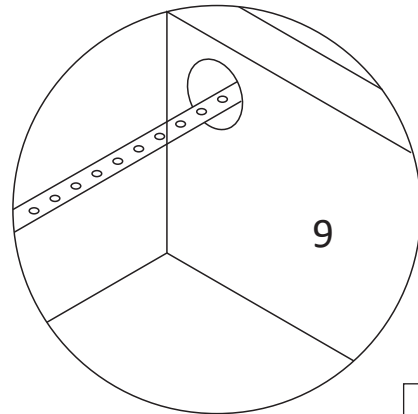
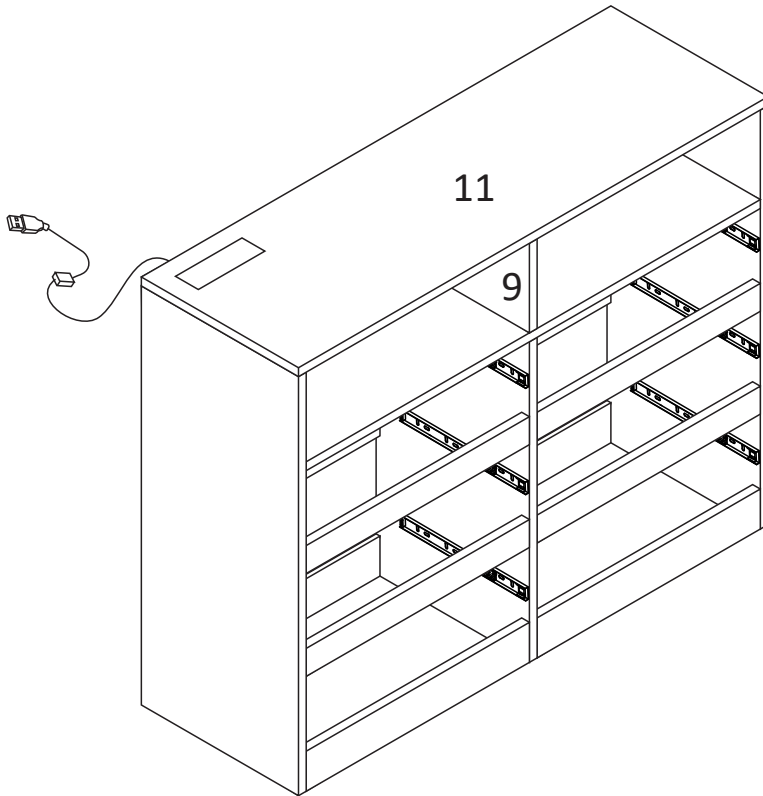

Step 18

I. Insert the thinnest side of Plastic wedge (F) into the gap between panel (1) and panel (7), and secure the Plastic wedge (F) with screws (C).

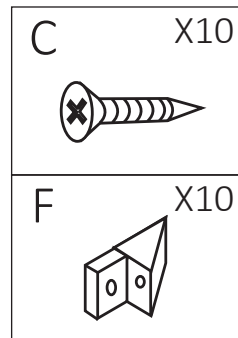
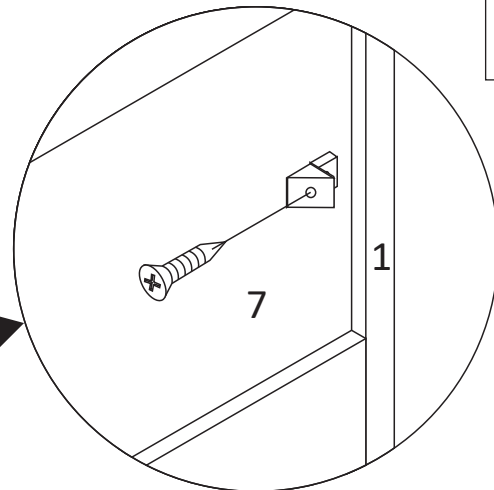
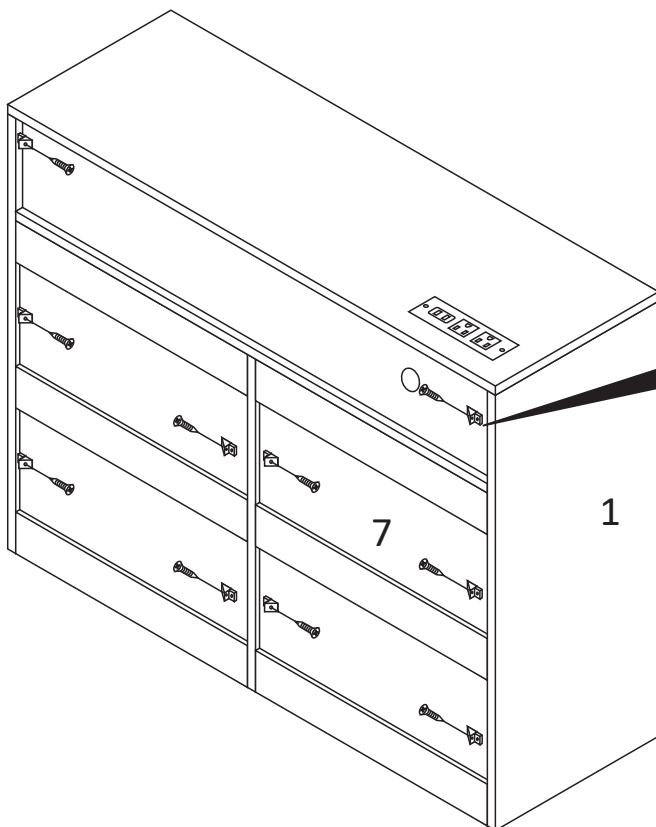

Step 19

- I. Screw in cam-bolt (A) into the designated holes on panel (12,13,14,17,18).
- II. Attach panel (12,14,16) to panel (13), insert cam-lock (B) into the panel (13,16), then turn clockwise to lock onto cam-bolt.
- III. Install panel (19) as per diagram and slide them into the grooves until they are fully seated.
- IV. Attach panel (17 or 18) to panel (12,14,16,19), insert cam-lock (B) into the panel (12,14), then turn clockwise to lock onto cam-bolt.

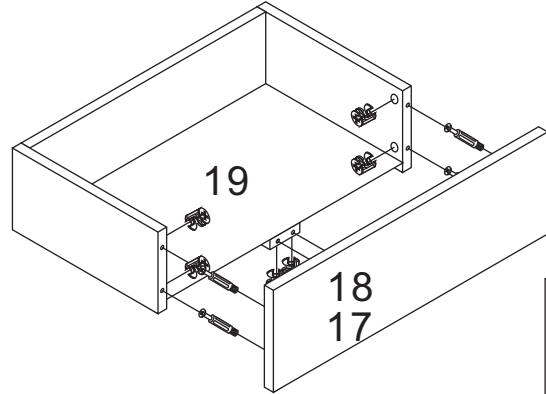
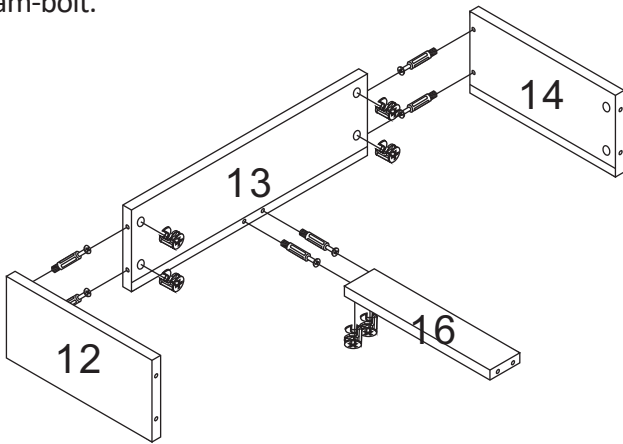

X6

A	X72
B	X72

Step 20

- I. Use screws (C) to secure the slide rail (E1) to the panel (12,14), and tighten them with a screwdriver.
- Note: For the correct orientation of slide rail (E1), please refer to the image.(front and back)

X6

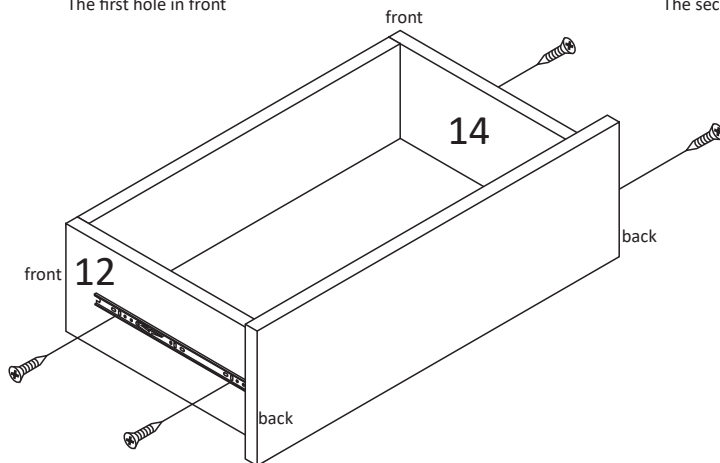
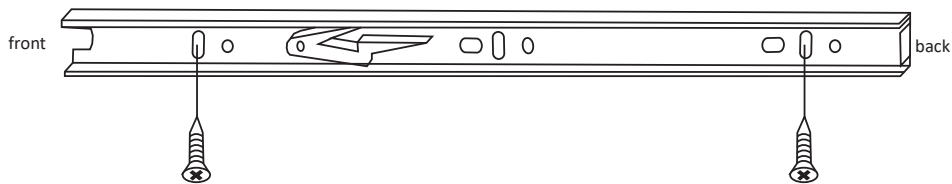

C	X24
E	X12

Step 21

I. Install the assembled drawer on the cabinet.

Note: Please install the panel (18) of the assembled drawer on the right as shown in the figure, and install the panel (17) of the assembled drawer on the left.

If drawer 17 and drawer 18 are not aligned vertically, you can adjust this screw (C) to align them: you can first use a screwdriver to loosen the screw (C), then move the panels (12,14) upward or downward, and then use a screwdriver to tighten the screw (C).

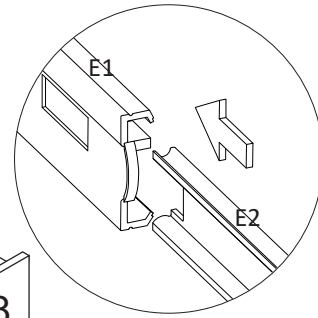
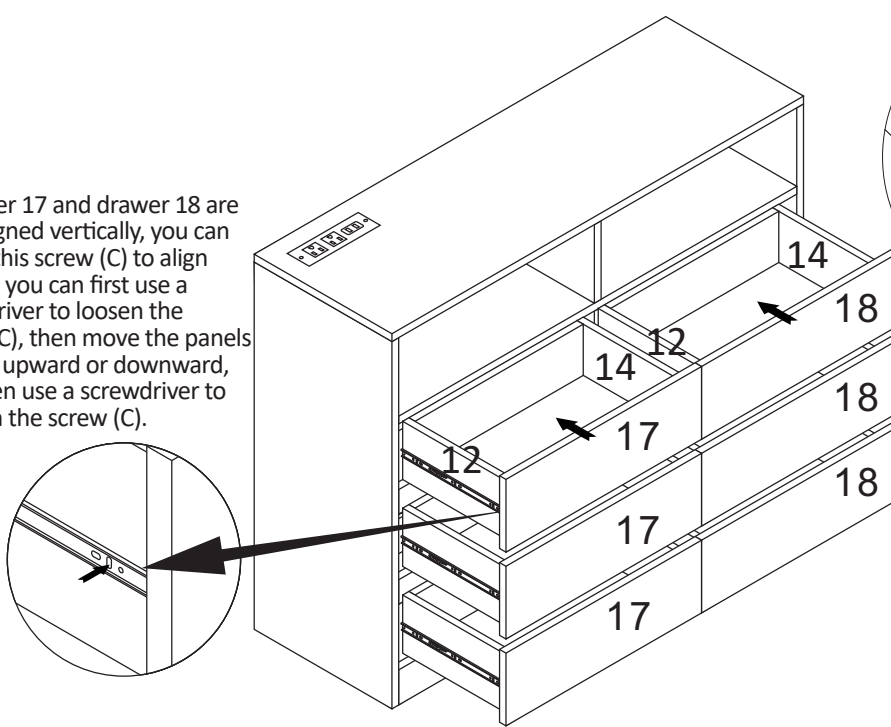

As shown in the figure, the slide rail (E2) is aligned with the slide rail (E1), and then push it in the direction of the arrow.

X2

Step 22

I. Install anti-tilt accessories: As shown in the figure, use short screws (G) to fix 2 pieces of plastic sheet to the panel (8).

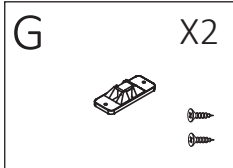
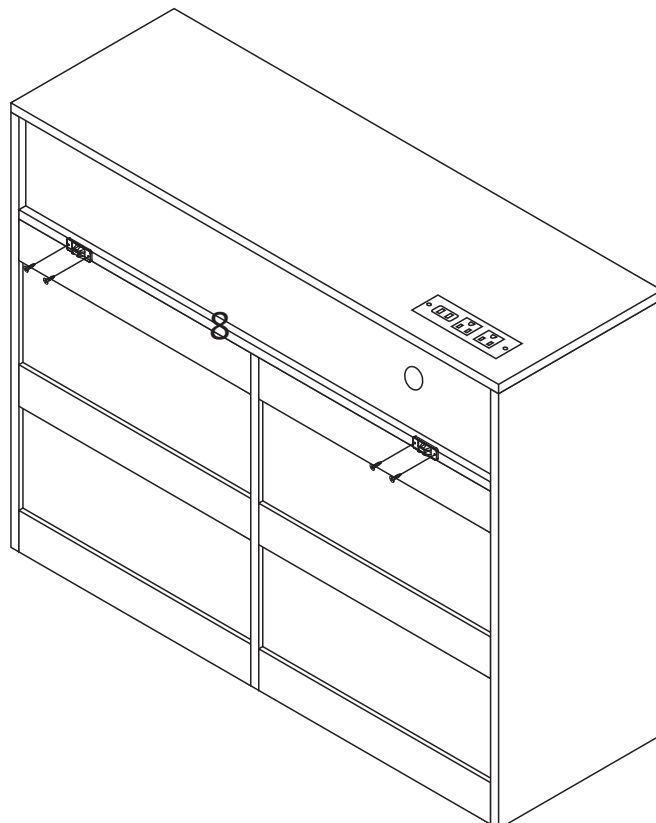
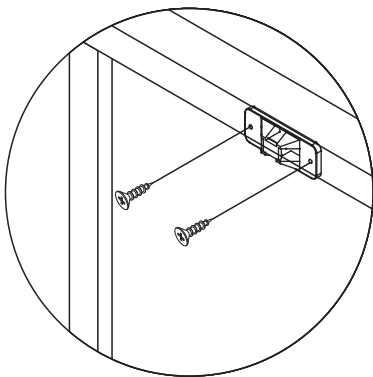

Step 23

- I. Mark the drill position on the wall with a pencil.
- II. Drill a small hole on the marked position.
- III. Insert the plastic peg into the drilled hole.
- IV. Fix the plastic sheet to the plastic peg with a long screw.

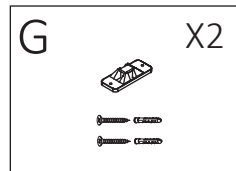
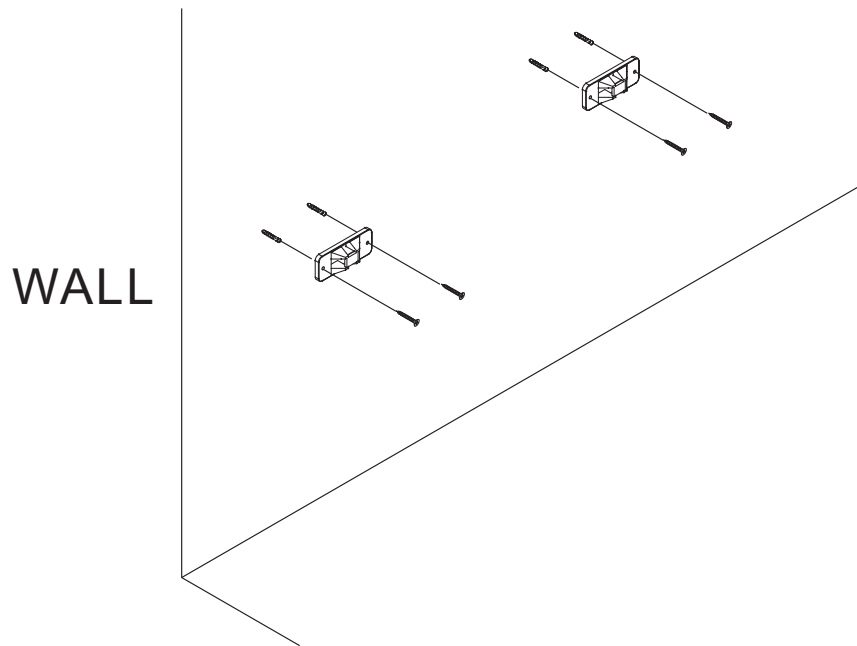

Step 24

- I. Use plastic strips to connect the plastic plate on the panel (8) to the plastic plate on the wall.

