

General Assembly Guidelines

- I. Ensure that all parts and hardware are available before beginning assembly.
- II. Follow each step carefully to ensure the proper assembly of this product.
- III. Two people are recommended for ease in the assembly of this product.
- IV. The three main types of hardware used to assemble this product are : wood dowels , screws and bolts.
- VI. A Phillips head screwdriver is required for the assembly of this product .

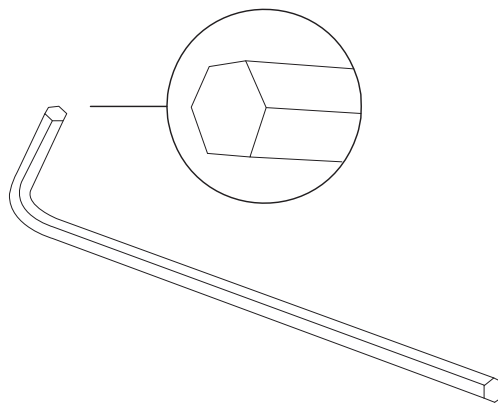

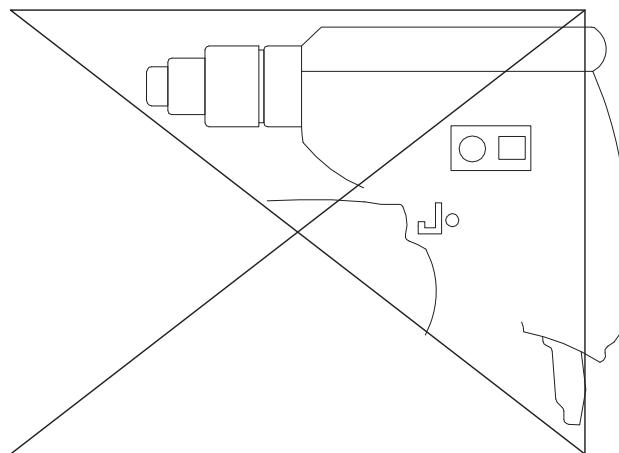

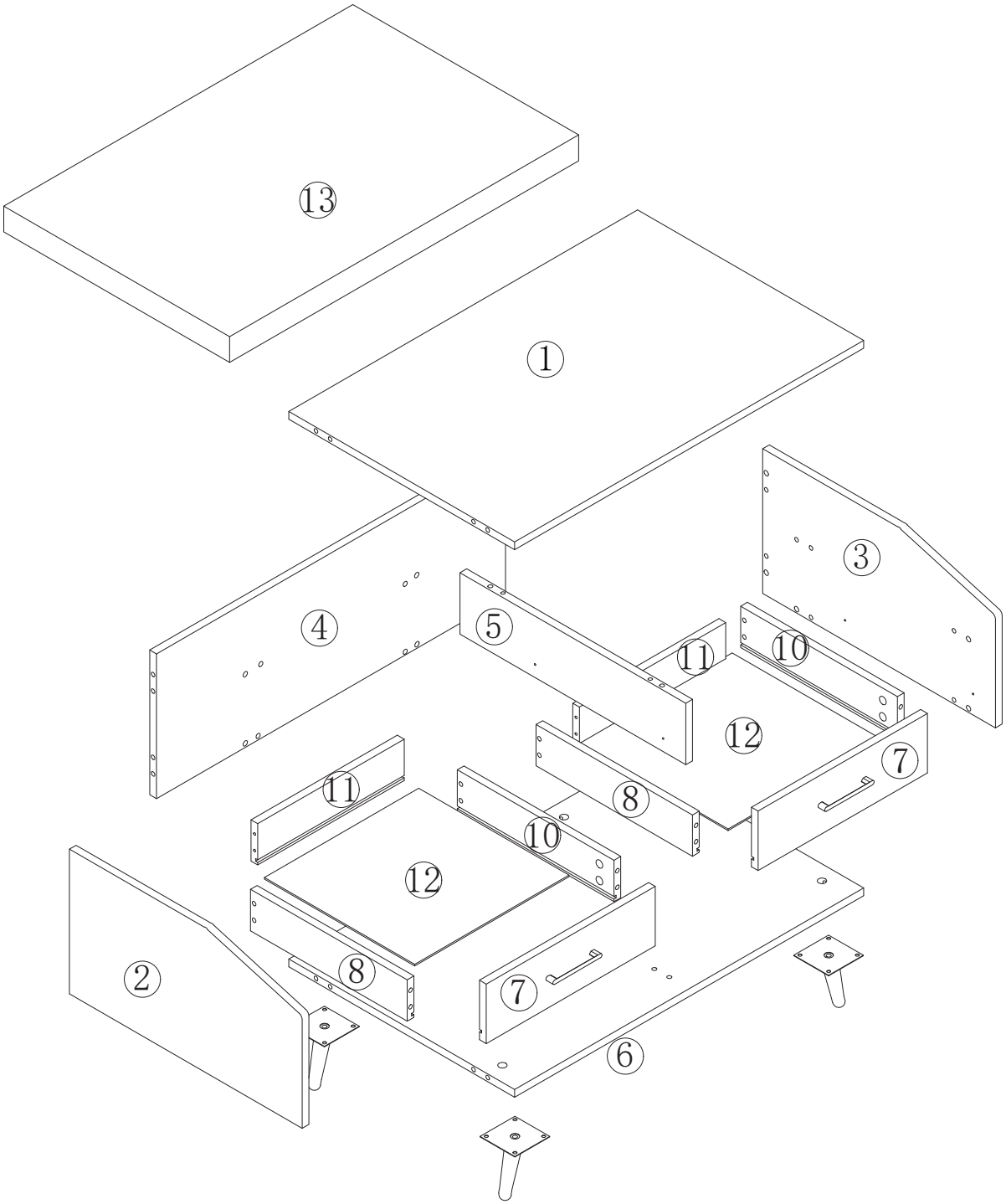

- VII. Power tools should not be used to assemble this product .

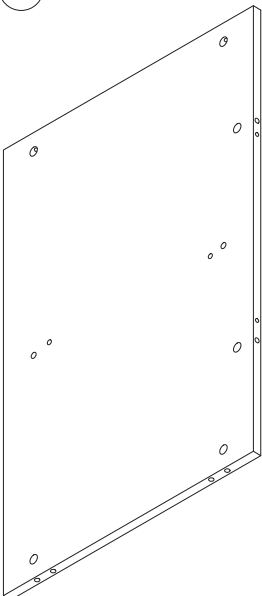
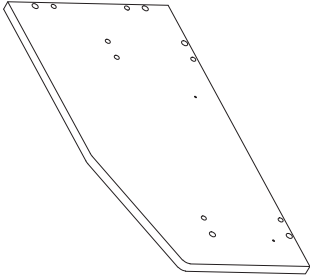
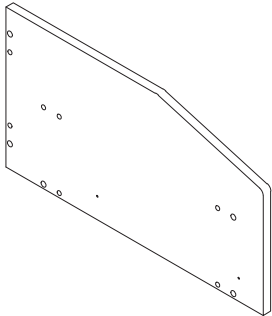
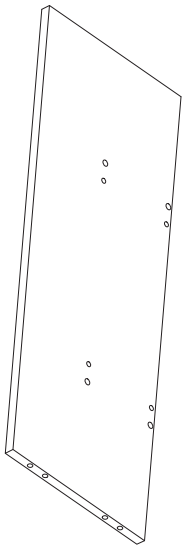
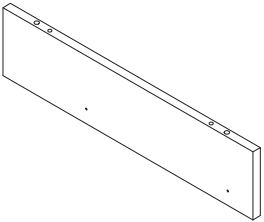
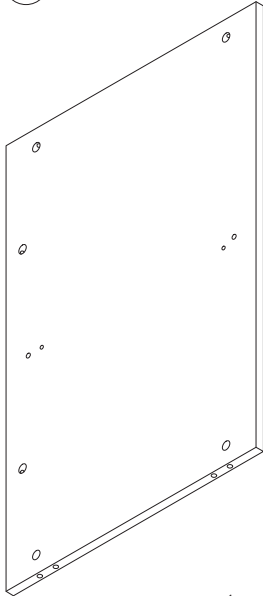
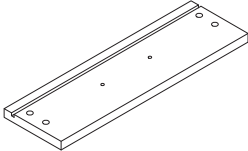
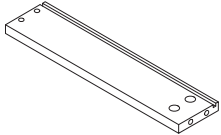
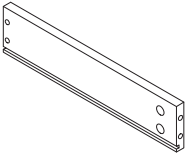
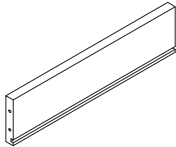
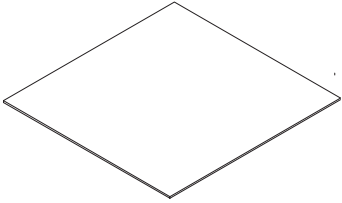
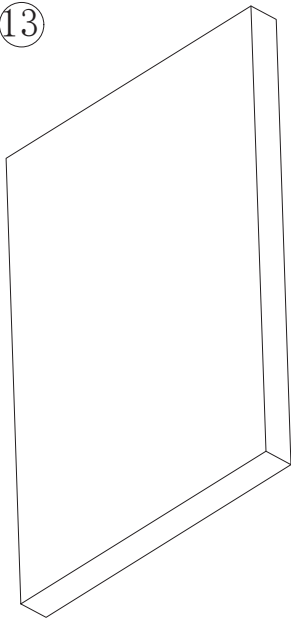

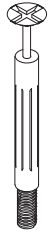

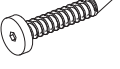
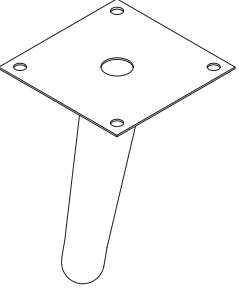
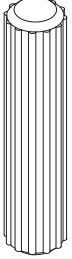
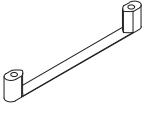
<p>① X1</p>  <p>780*505*15 (MM)</p>	<p>② X1</p>  <p>520*280*15 (MM)</p>	<p>③ X1</p>  <p>520*280*15 (MM)</p>	<p>④ X1</p>  <p>780*280*15 (MM)</p>
<p>⑤ X1</p>  <p>505*119*15 (MM)</p>	<p>⑥ X1</p>  <p>780*505*15 (MM)</p>	<p>⑦ X2</p>  <p>378*115*15 (MM)</p>	<p>⑧ X2</p>  <p>350*80*15 (MM)</p>
<p>⑩ X2</p>  <p>350*80*15 (MM)</p>	<p>⑪ X2</p>  <p>327*80*15 (MM)</p>	<p>⑫ X2</p>  <p>345*336*3 (MM)</p>	<p>⑬ X1</p>  <p>780*505*50 (MM)</p>

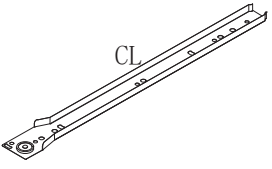
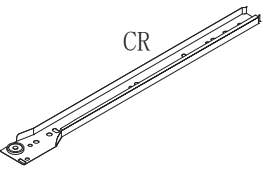
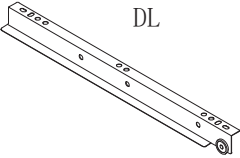
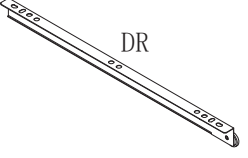
<p>(A)</p>  <p>26PCS</p>	<p>(B)</p>  <p>$\phi 15$ 26PCS</p>	<p>(C)</p>  <p>M3.5*14 32PCS</p>	<p>(D)</p>  <p>M5*40 10PCS</p>
<p>(E)</p>  <p>4PCS</p>	<p>(F)</p>  <p>20PCS</p>	<p>(G)</p>  <p>2PCS</p>	<p>(H)</p>  <p>M4*18 4PCS</p>
<p>(CL)</p>  <p>2PCS</p>	<p>(CR)</p>  <p>2PCS</p>	<p>(DL)</p>  <p>2PCS</p>	<p>(DR)</p>  <p>2PCS</p>

I

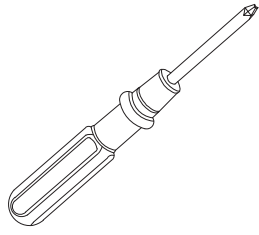
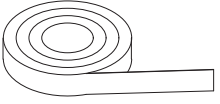

1PCS

Step 1

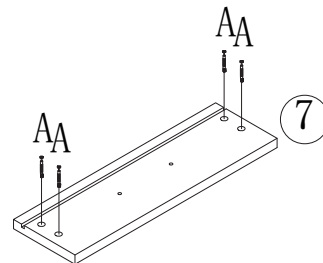
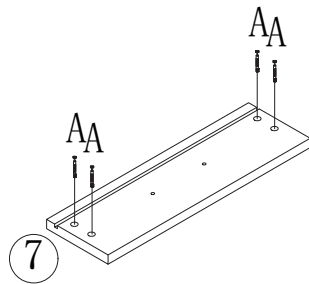
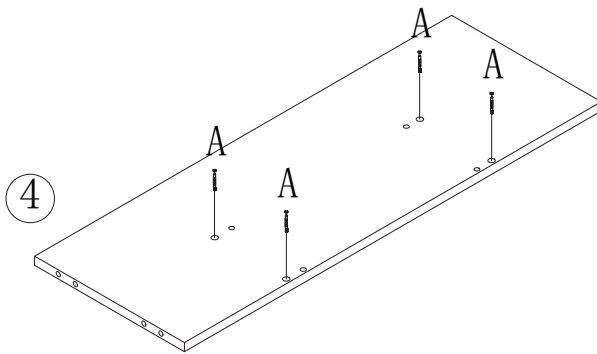
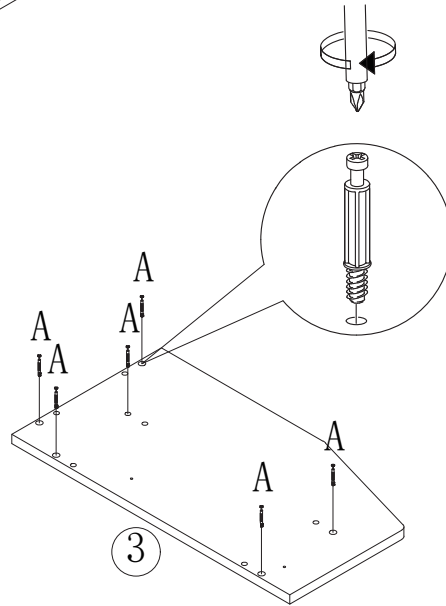
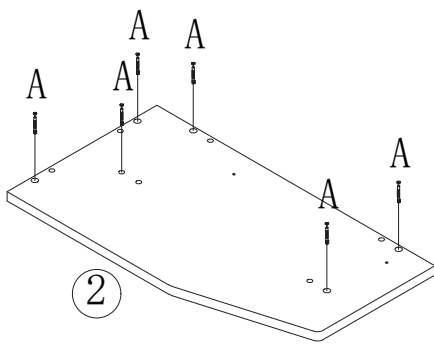
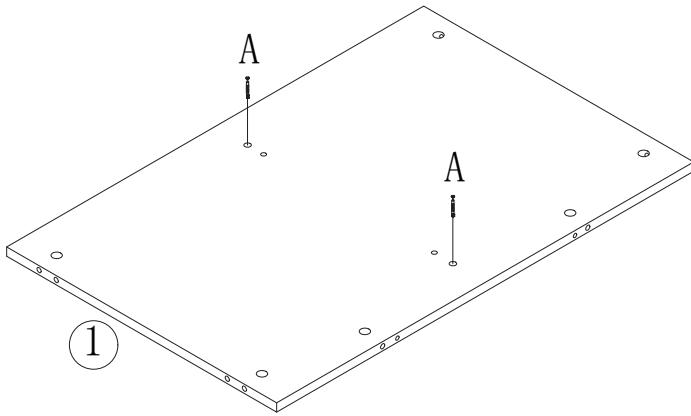
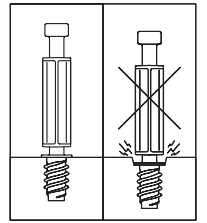

Step 2

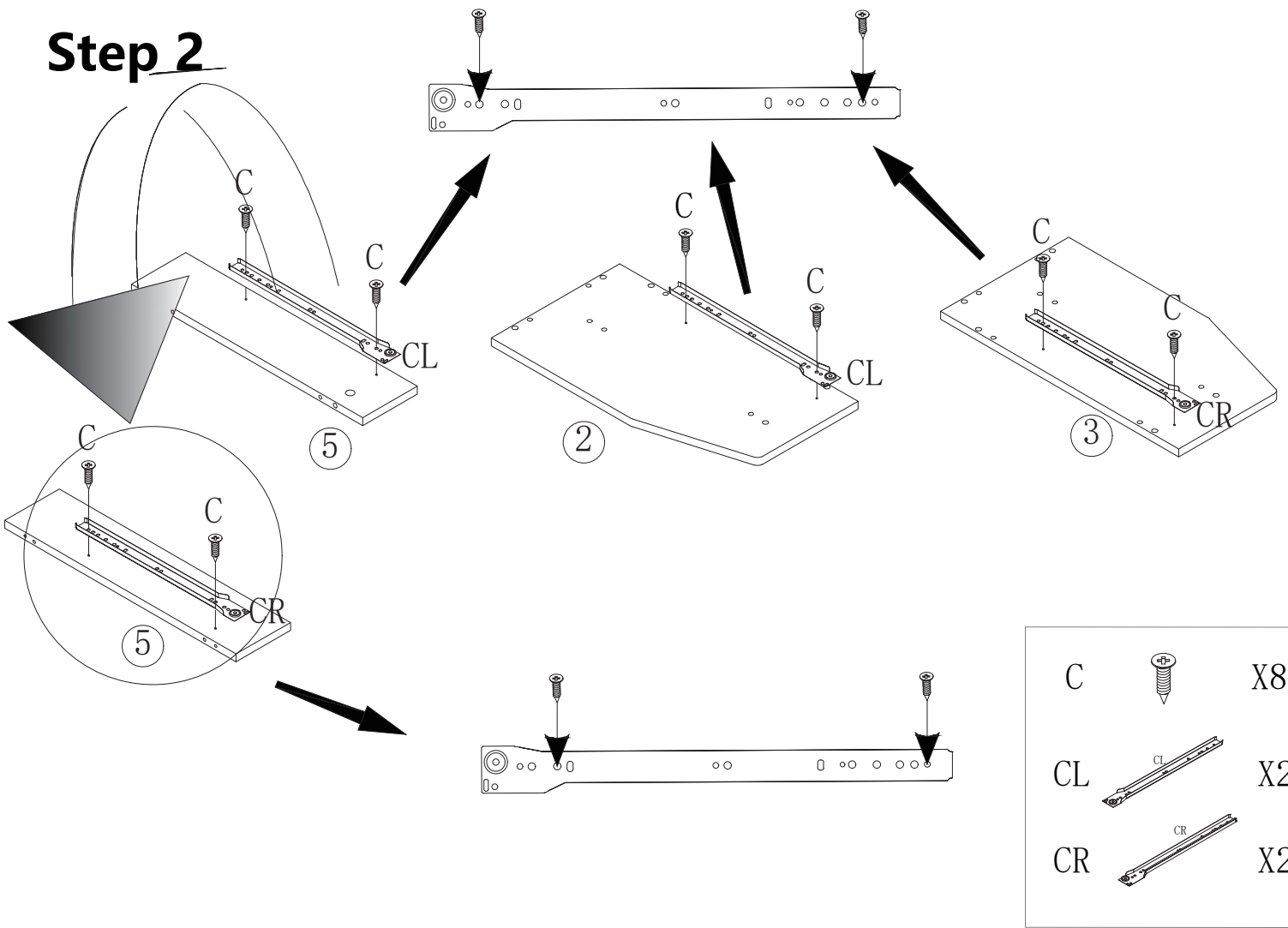

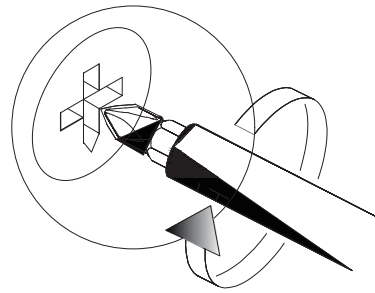
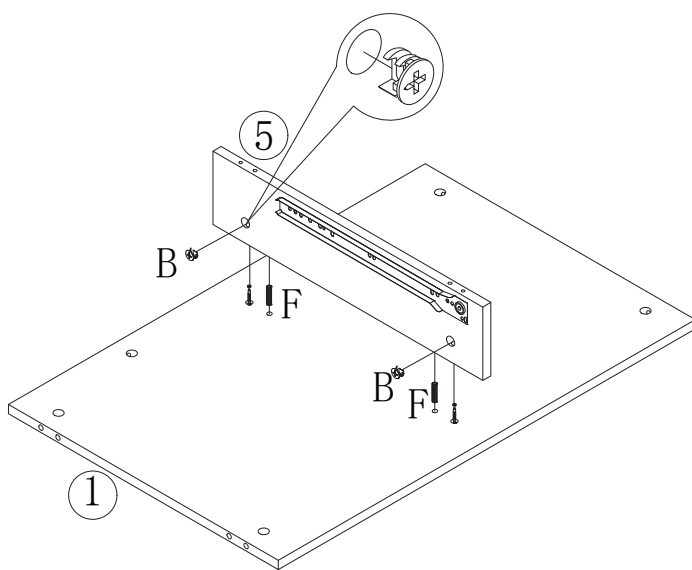

Step 3

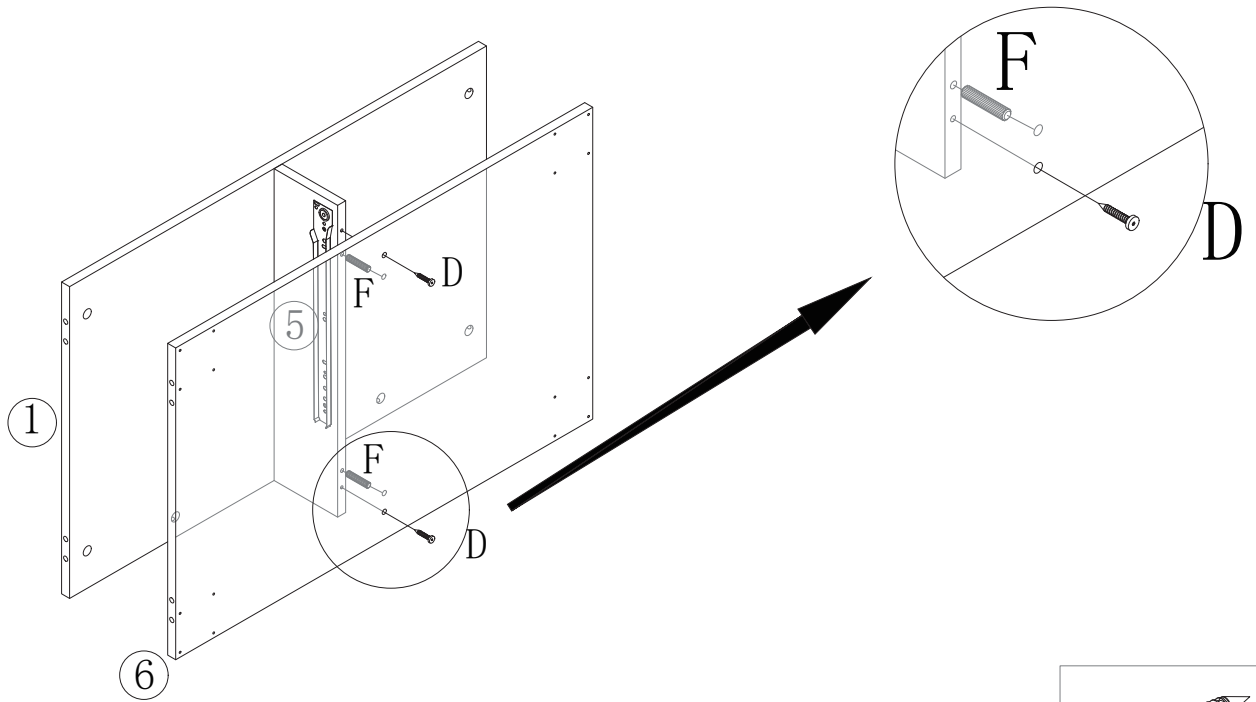

B		X2
F		X2

Step 4



D		X2
F		X2

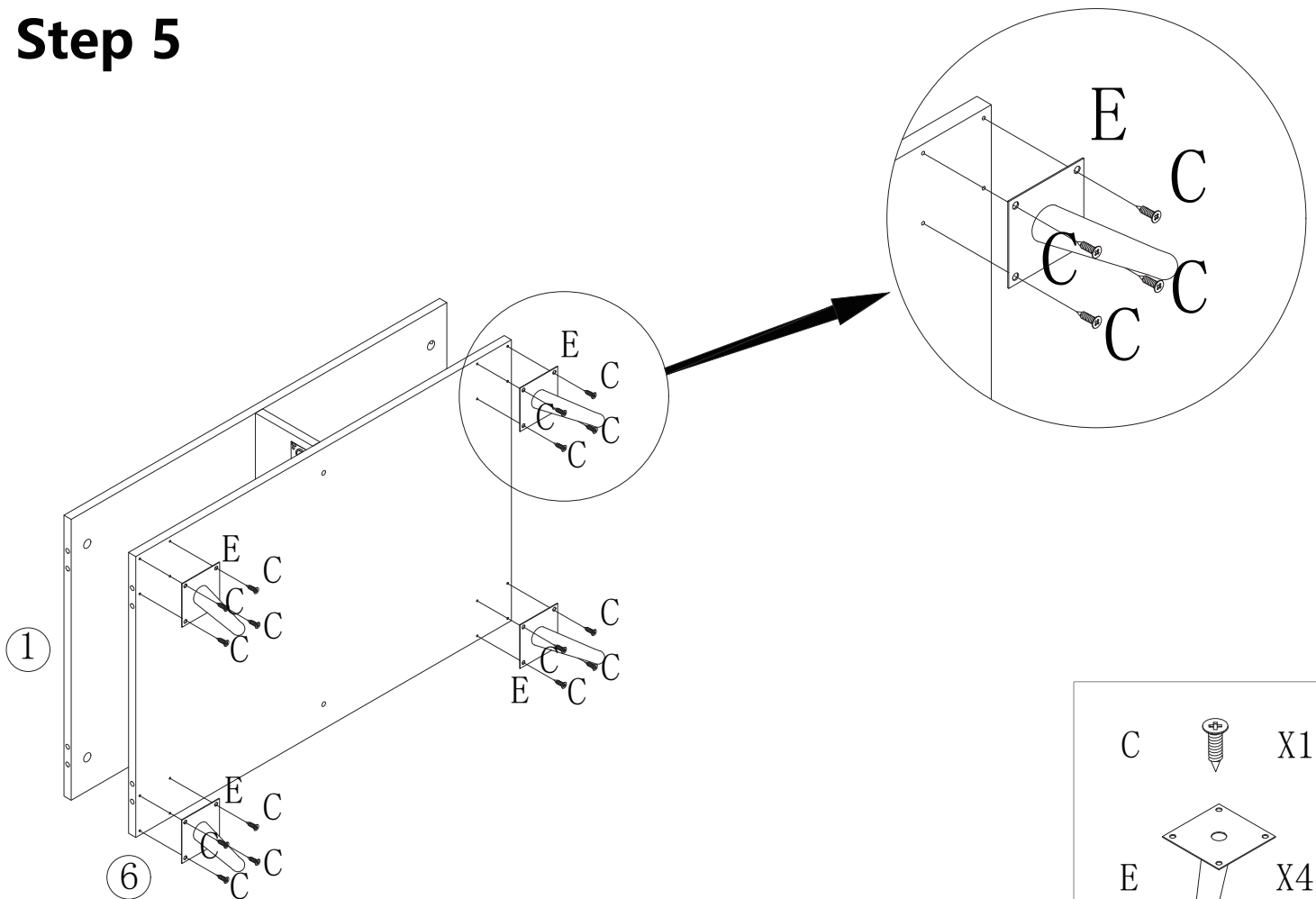

Step 5

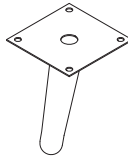

C		X16
E		X4

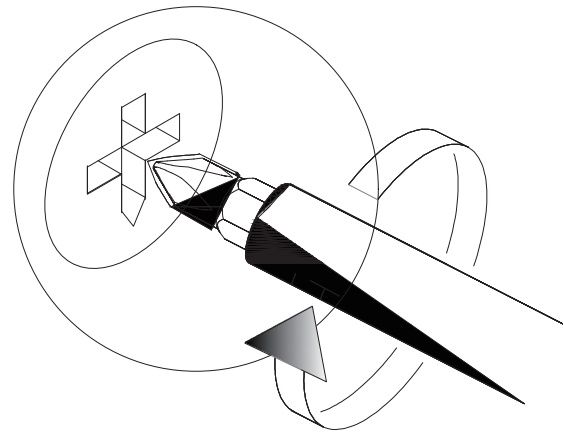
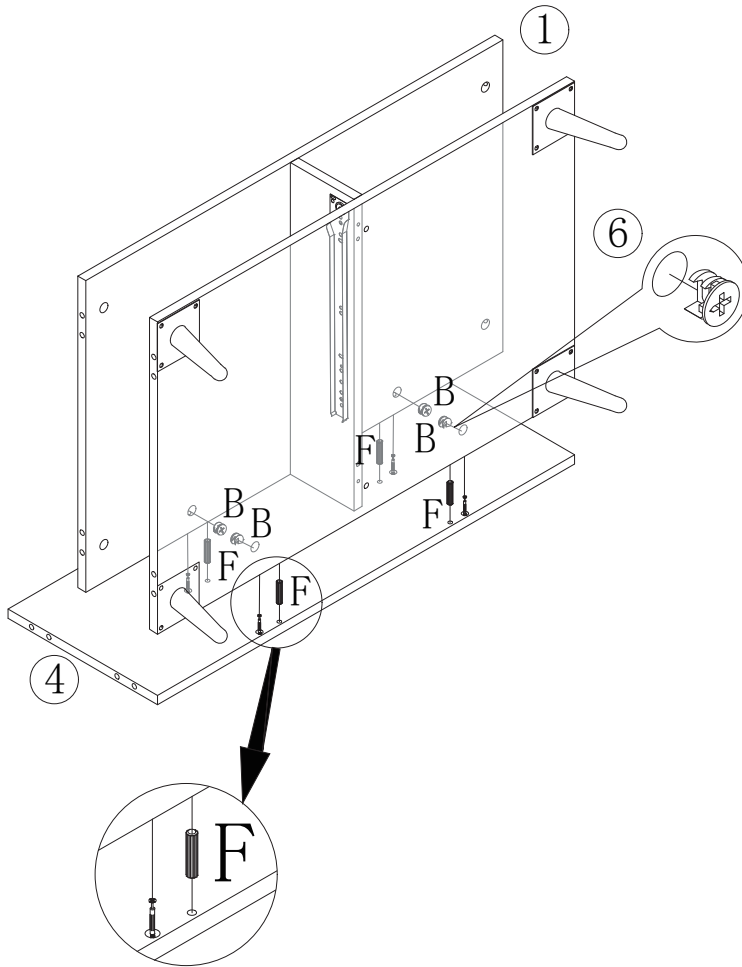

Step 6

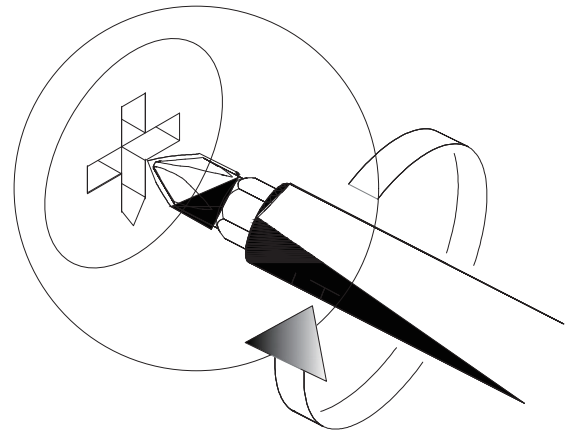
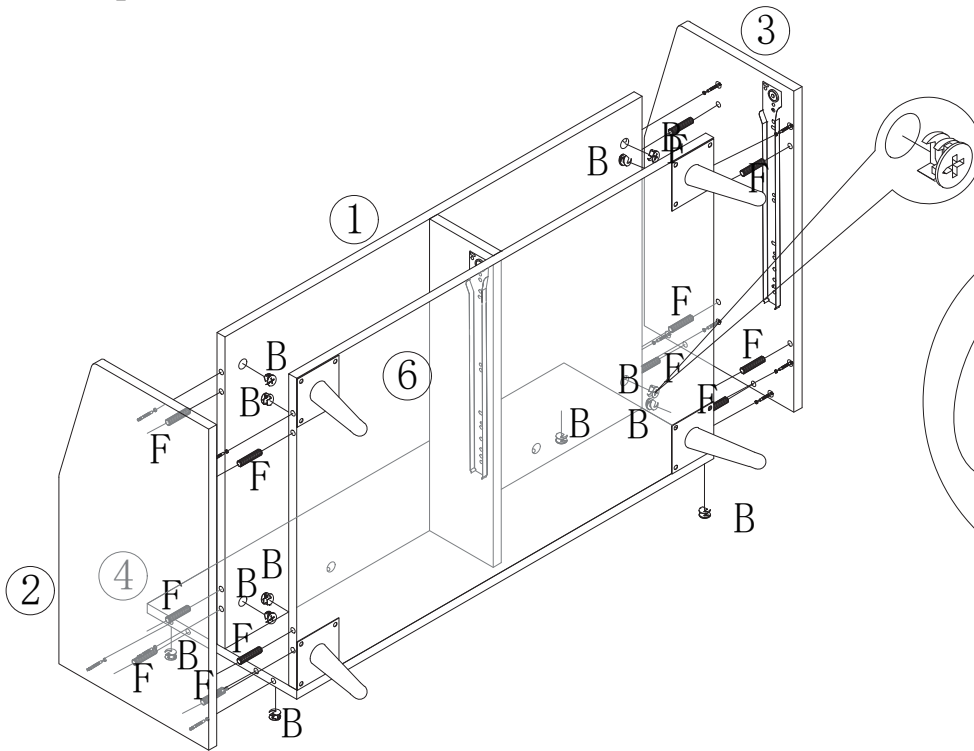

B		X4
F		X4

Step 7



B		X12
F		X12

Step 8

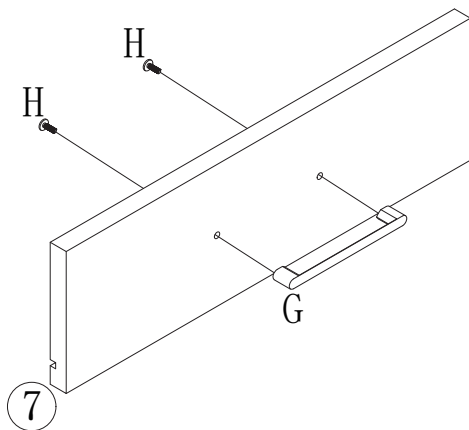
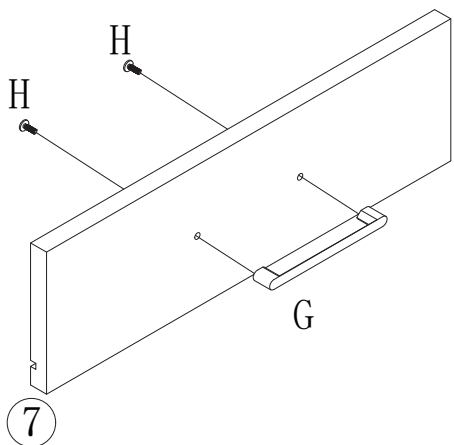

G		X2
H		X4

Step 9

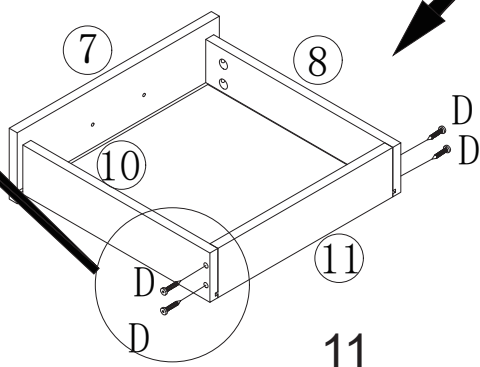
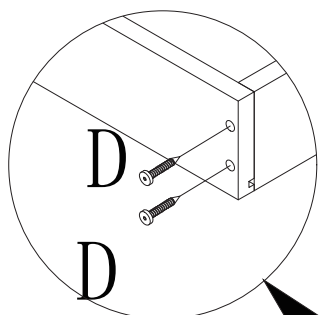
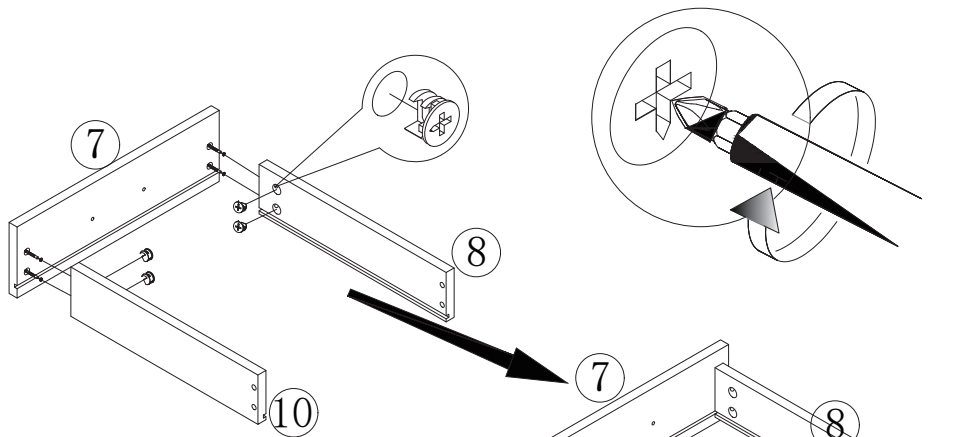

X2

B		X8
D		X8

Step 10

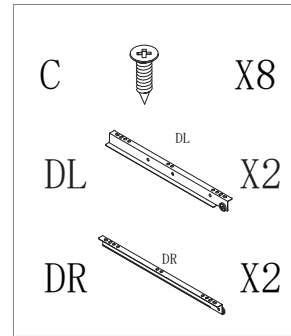
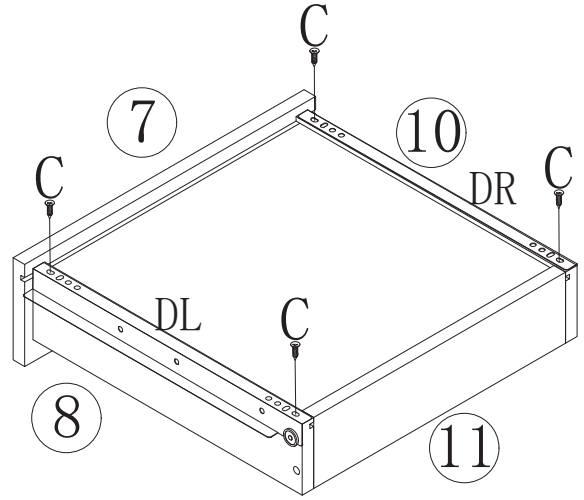
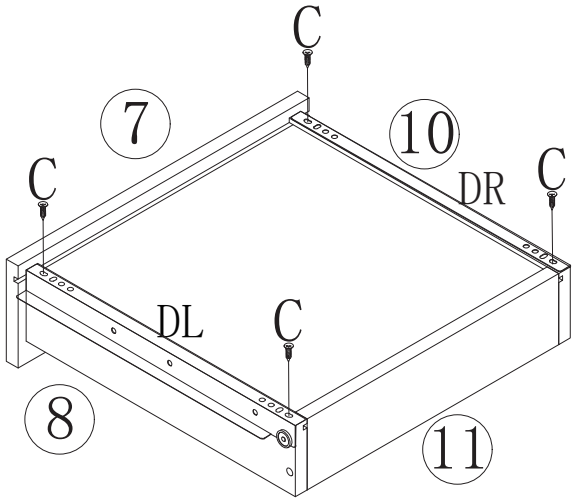

Step 11

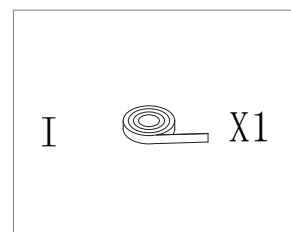
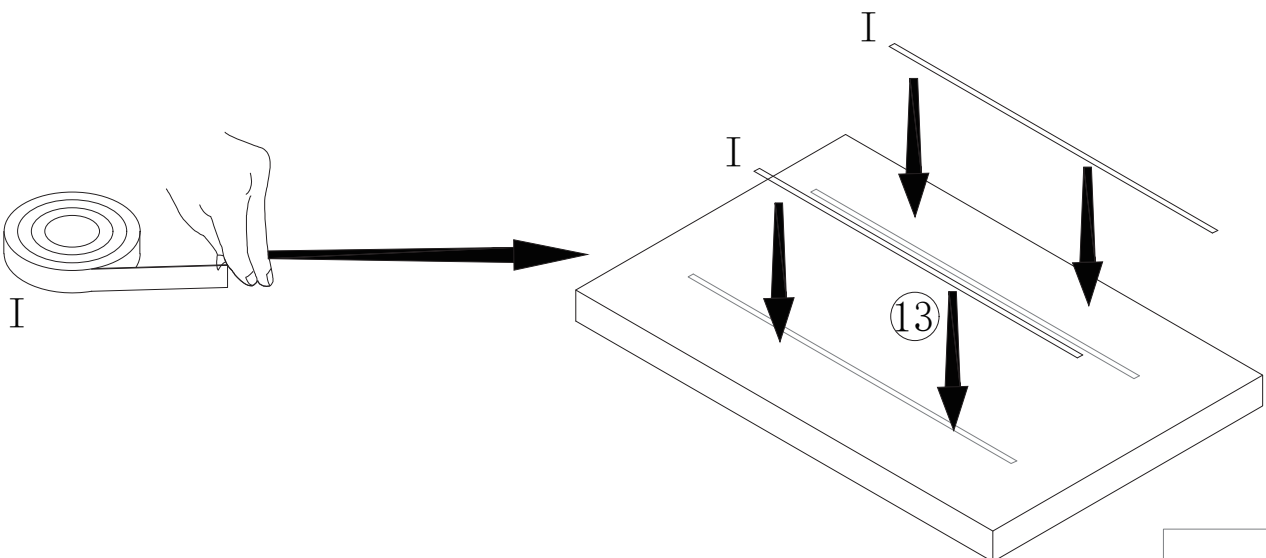

Step 11

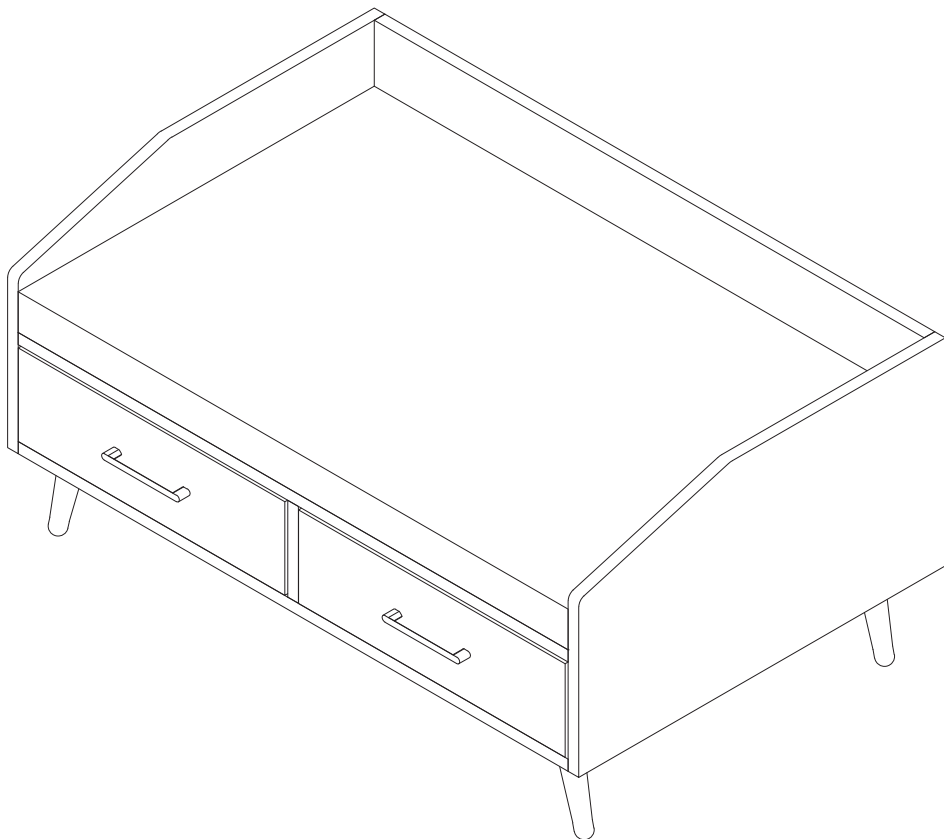
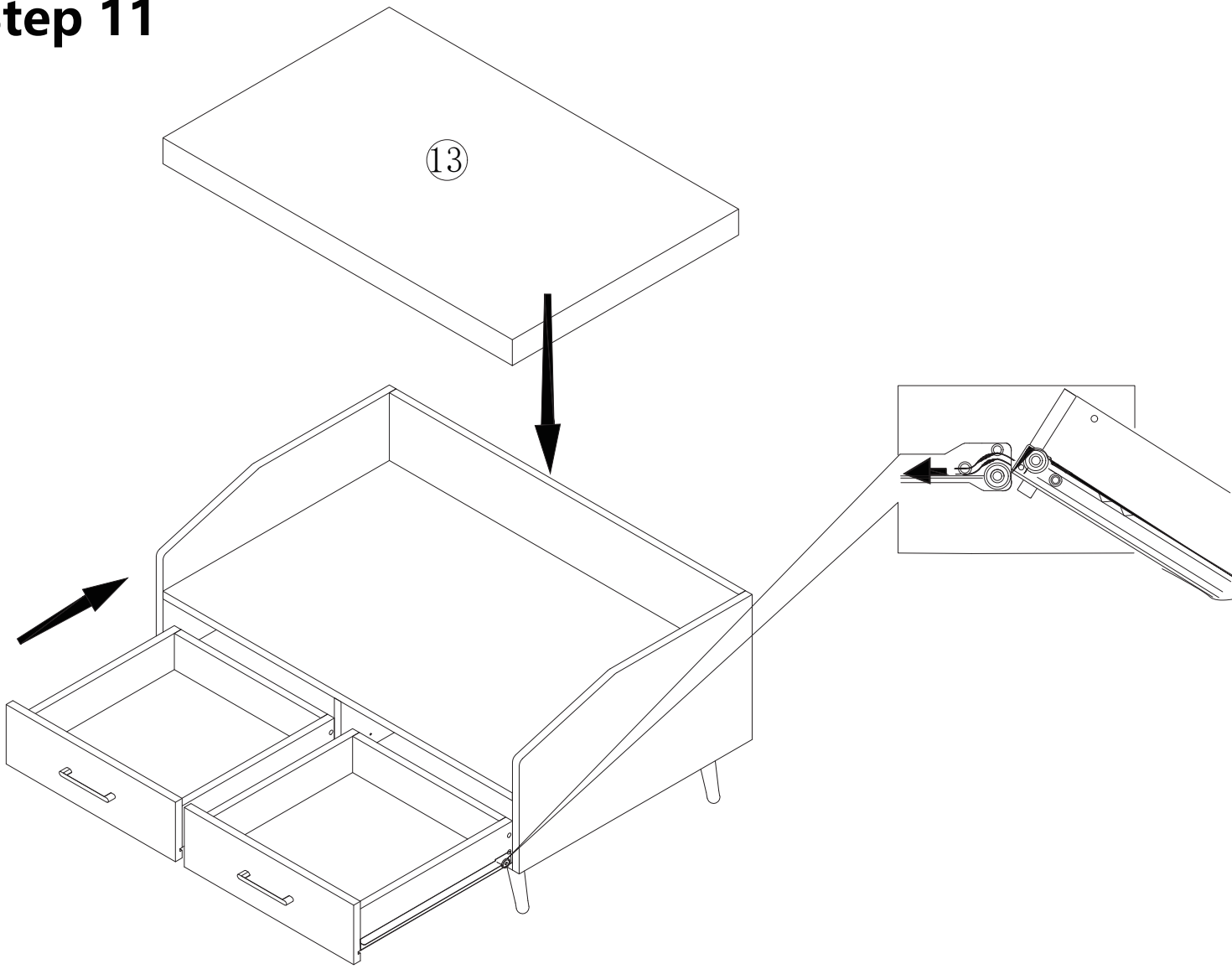

NOTES

Security/ Notice

To ensure safe installation and use of this product, please follow these security notices:

- During initial assembly, fasten screws loosely and avoid firmly tightening them until the item is fully assembled.
- Some parts of the product may be heavy and have sharp edges. Please handle with care.
- Stop using this item immediately if any parts are missing, broken, damaged, or worn, until repairs are made or factory replacement parts are installed.
- Reconfirm that all bolts, screws, and knobs are securely fastened every 90 days.
- Avoid using this item in a way inconsistent with the manufacturer's instructions, as this could void the product warranty.

NOTES

Warranty Guidelines

We offer a limited warranty period that begins on the date of shipment from for factory direct purchases, or on the date of purchase from an authorized reseller. Please keep a copy of your purchase receipt.

If this product or any associated parts are found to be defective or missing at the time of receipt, will repair or replace the defective parts at no charge to the original purchaser. Replacement parts or repaired parts shall be covered for the remainder of the Original Limited Warranty Period. All shipping costs will be the responsibility of the seller.

We provide continuous free technical support, including online diagnosis and troubleshooting to help solve any issues that arise. To process your warranty claim, please upload a copy of your receipt along with AT LEAST 2 photos of the issue/damaged parts. Failure to do so may result in the supplier refusing replacement parts or credit.

What is not covered by this limited warranty?

- Item past the warranty.
- Products that have been subjected to abuse, obesity, accident, alteration, modification, tampering, vandalism, negligence, misuse, abrasive contact, faulty installation or lack of reasonable care.
- Damage to the contents of products, any person or property is excluded. Normal and foreseeable service wear or tear.
- Parts were damaged due to improper installation or assembly.
- Damage that occurs due to acts of nature, i.e. hurricane, tornado, wind, flood, snow, wind driven debris, etc.
- Third party labor or installation fees of any kind are not recoverable under the warranty.
- Other circumstances are stipulated by law.

NOTES

Return Policy

We want you to be completely satisfied with your purchase. If for any reason you are unsatisfied with the product or have received the wrong item, you may return it within 1 month of receiving the item. To initiate the return process, simply contact us via platform message, and we will provide you with a free prepaid return label.

Please note that the item should be returned in its original unused condition and in the original packaging. Once we have received and inspected your returned order, refunds typically take 2 business days. However, please be aware that the refund may be partially deducted in the following cases:

1. If the returned item condition is different from reported.
2. If parts used or missing from the returned item
3. If the return is due to buyer remorse, such as the item no longer being needed, wrong color/size purchased, doesn't fit or is not liked. Please keep in mind that the Return Policy may not apply in all cases, depending on factors such as the condition of the product, where the product was purchased, or whom you purchased the product from. If you have any questions, please email the purchase platform.