











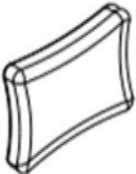

ASSEMBLY INSTRUCTION

NUMBER	COMPONENT	QUANTITY
A	 <p>SEAT PANLE</p>	1
B	 <p>BACKREST PANLE</p>	1
C	 <p>RIGHT LEG PANLE</p>	1
D	 <p>LEFT LEG PANLE</p>	1
E	 <p>SEATCUSHION</p>	1
F	 <p>BACK CUSHION</p>	2

ASSEMBLY INSTRUCTION

NUMBER	COMPONENT	QUANTITY
1	 <p>Screw (M6 x 70mm)</p>	3
2	 <p>Screw (M6 x 50mm)</p>	7
3	 <p>Bolt (M6 x 20mm)</p>	3
4	 <p>Bolt (M6 x 30mm)</p>	5
5	 <p>Washer</p>	9
6	 <p>Allen Wrench</p>	2
7	 <p>Sleeve Nut (6x13mm)</p>	3

ASSEMBLY INSTRUCTION

①

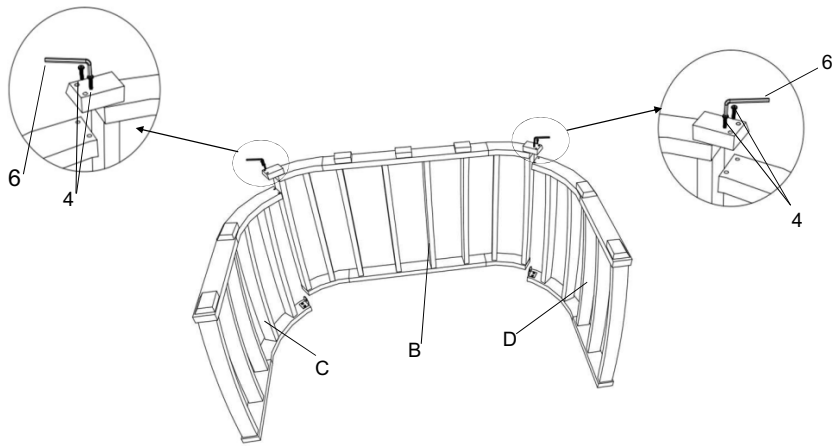

Place the Backrest Panel(B) stand onto a clean, non-marring surface and flip it.
1.1) Attach the Right Leg Panel(C) to the Backrest Panel(B) using Bolt(4) and AllenWrench(6).
1.2) Attach the Left Leg Panel(D) to the Backrest Panel(B) using Bolt(4) and AllenWrench(6).
Note : only eighteen 80%.

②

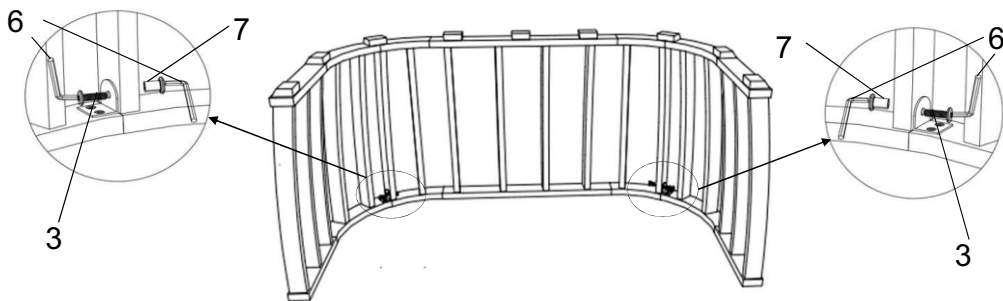

Using Bolt(3), Sleeve Nut(7) and Allen Wrench(6) to tighten the assembled part in Step 2.
Note : only eighteen 80%.

ASSEMBLY INSTRUCTION

③

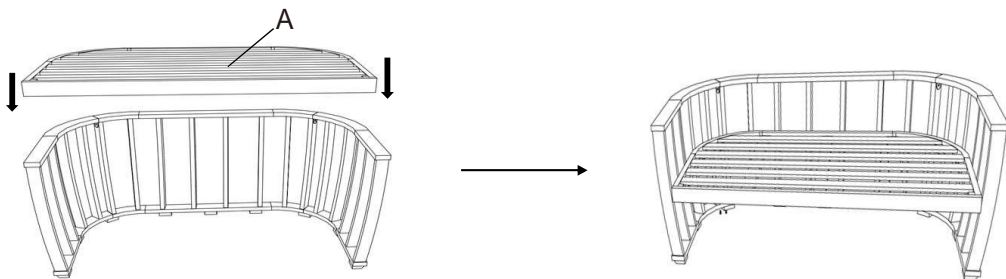

With the assistance from your partner, turn the right side of the assembled part in Step 2 up, place the Seat Panel(A) onto it as shown above.

④

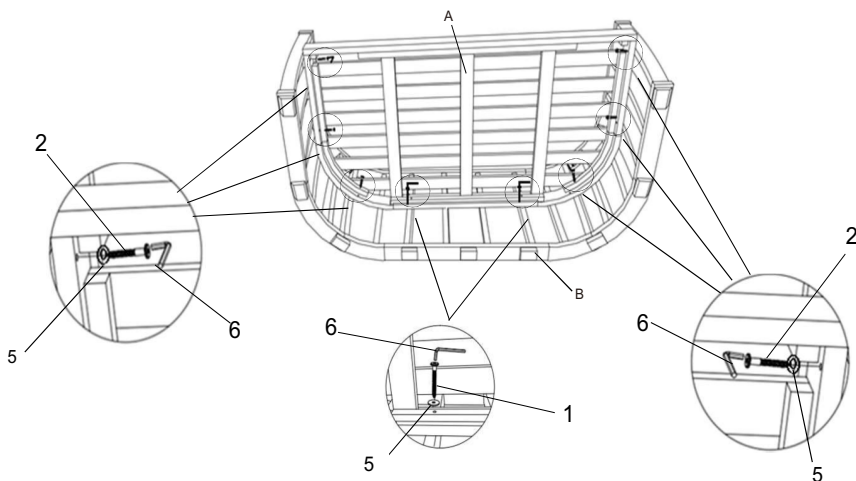

With assistance from your partner, lay assembled part in Step 4 down as shown above. Position the Seat Panel(A) at frame using Screw(1), Screw(2), Washer(5) and AllenWrench(6).
Note : only eighteen 80%.

ASSEMBLY INSTRUCTION

⑤

