

Dining Table

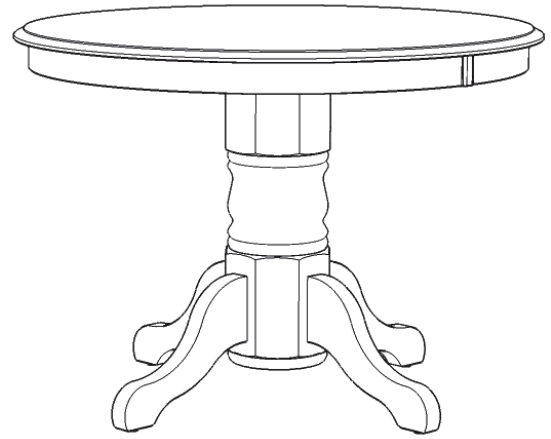

IMPORTANT

Carefully remove all the parts from the carton and place them individually on a soft cloth to prevent scratches or other damage.

Carefully and strictly follow these assembly instructions to ensure a completed product as designed.

Do not use power tools above 8 volts to assemble.

Part List

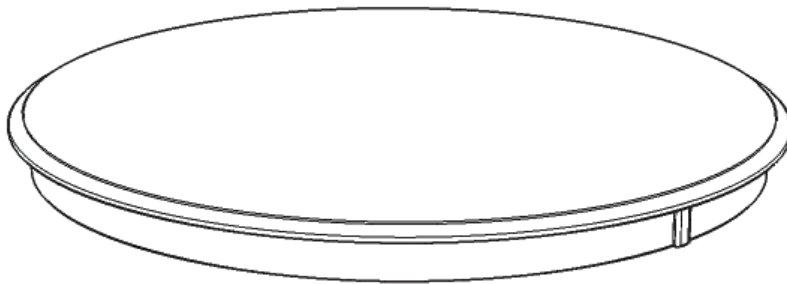

A.
Top
1 pc.



B.
Panel
1 pc.

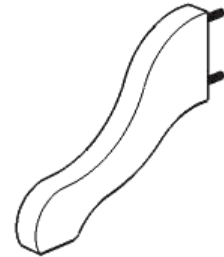

D.
Leg
4 pcs.

Hardware List



Key Wrench
1 pc.



Hex Wrench
1 pc.



Small Hex Wrench
1 pc.



Nut
12 pcs. (+1 extra)

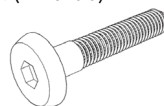

M6x40
Head Cap Bolt
4 pcs. (+1 extra)



Spring Washer (large)
12 pcs. (+1 extra)



Spring Washer (small)
4 pcs. (+1 extra)

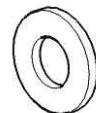

Flat Washer (large)
12 pcs. (+1 extra)



Flat Washer (small)
4 pcs. (+1 extra)

Assembly Instructions 2/3

IMPORTANT

- Use a soft cloth between these parts and the floor.
- Do not use power tools above 8 volts to assemble.
- Do not tighten all the bolts until each part is properly assembled.
- The unit must be level to work properly. Use the included adjustable levelers to level.
- Keep Key Wrench and Hex Wrench as the bolts may need to be tightened in the future.

STEP 1

Attach Panel (B) to Pedestal (C) with Flat Washers (large), Spring Washers (large) and Nuts. (See Figure 1)

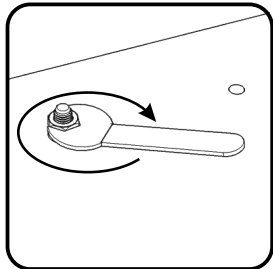

Figure 1

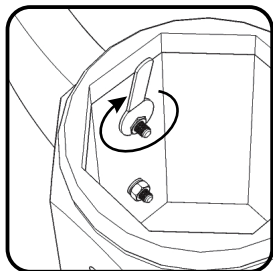
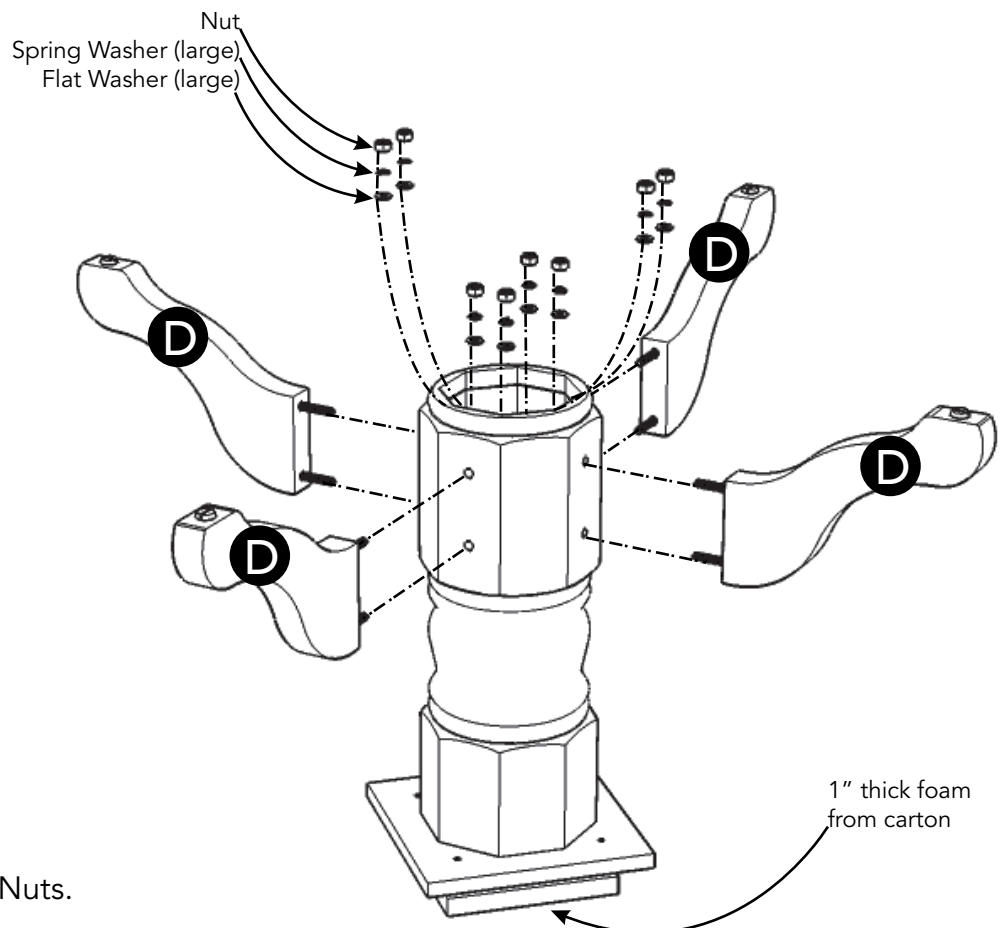
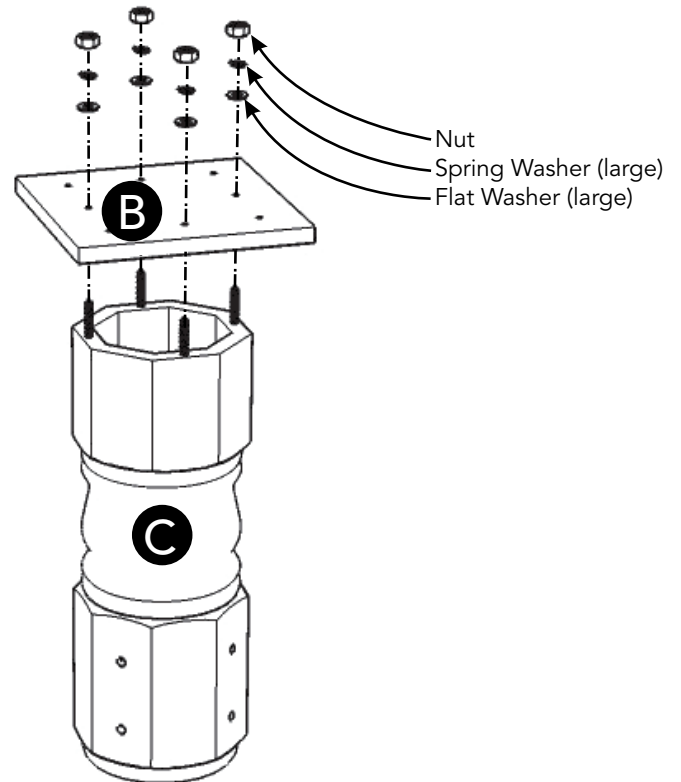

Figure 2

STEP 2

Place unit upside down on 1" thick foam from carton.

Attach Legs (D) to unit with Flat Washers (large), Spring Washers (large) and Nuts. (See Figure 2)



Assembly Instructions 3/3

STEP 3

Place Top (A) upside down on a soft cloth.

Attach unit to Top (A) with Flat Washers (small), Spring Washers (small) and Head Cap Bolts. (See Figure 3)

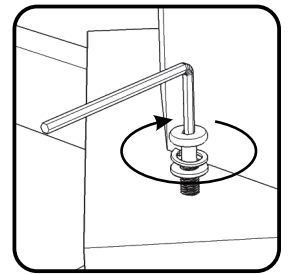
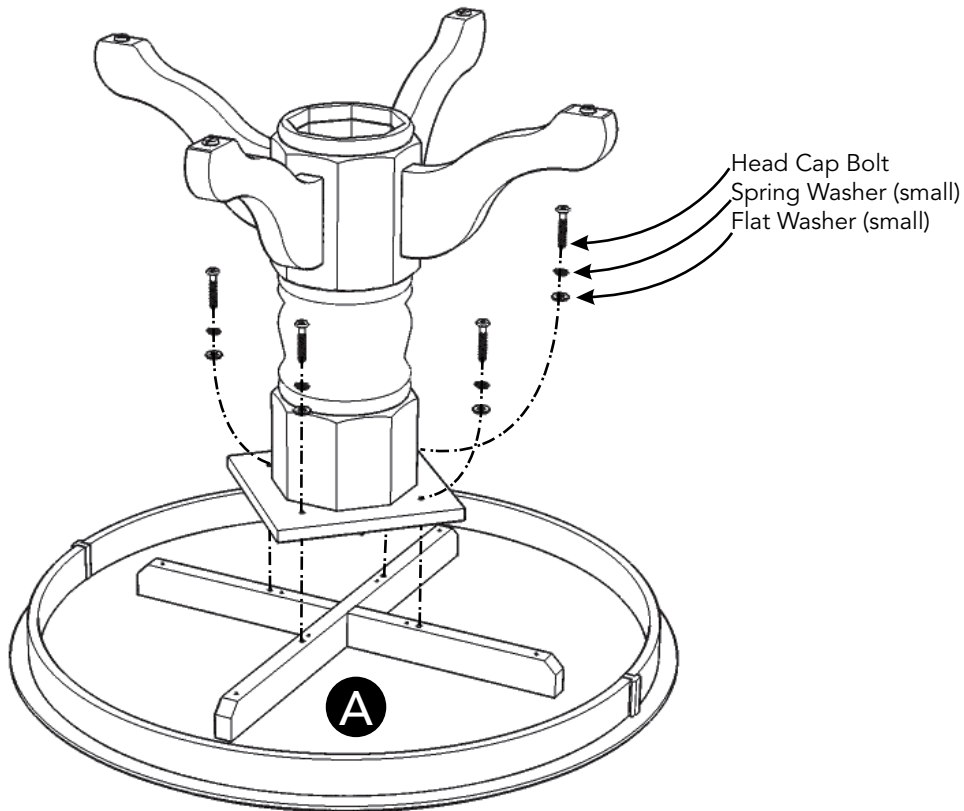

Figure 3

STEP 4

Turn unit over to its upright position.

Level unit by adjusting the adjustable levelers on bottom of unit. (See Figure 4)

(See Figure 4)

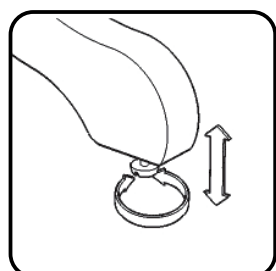

Figure 4

