

| Sofa

THE FOLLOWING INFORMATION:

- Order number
 - Purchase platform
 - Purchase date
 - Detailed description of the issue along with photos (if applicable)
-

Important – Please read these instructions carefully before starting the installation.

IMPORTANT/WICHTIG/ATENCIÓN

IMPORTANT/IMPORTANTE



EN - We recommend **1** or more people to install.
DE - Wir empfehlen, dass die Montage von **1** oder mehreren Personen durchgeführt werden sollte.
ES - Recomendamos realizar el ensamble con **1** o más personas.
FR - Il est recommandé d'effectuer le montage à **1** personne(s) ou plus.
IT - È necessaria la presenza di **1** o più persone per il montaggio di questo prodotto.



EN - The expected assembly time is **1** h.
DE - Die Montagezeit beträgt durchschnittlich **1** h.
ES - El tiempo aproximado de ensamble es de **1** h.
FR - Le temps nécessaire est estimé à **1** h.
IT - Il tempo previsto per il corretto assemblaggio è di **1** h.



EN - Not intended for use by children.
DE - Nicht geeignet für Kinder.
ES - Producto no apto para niños.
FR - Produit non destiné à être utilisé par des enfants.
IT - Questo prodotto non è destinato all'uso da parte dei bambini.



EN - Keep away from fire or other heat sources.
DE - Bitte von Feuer und Hitzequellen fernhalten.
ES - Manténgase alejado de las llamas y otras fuentes de calor.
FR - Tenir à distance des flammes et autres sources de chaleur.
IT - Tenere lontano dal fuoco o da altre fonti di calore.



EN - We recommend wearing protective gloves.
DE - Wir empfehlen das Tragen von Schutzhandschuhen.
ES - Recomendamos el uso de guantes de seguridad.
FR - Il est recommandé de porter des gants de protection.
IT - Per il processo di assemblaggio, consigliamo fortemente l'utilizzo di guanti protettivi.

CUSTOMER SERVICE GUIDE

Thank you for choosing our product! We are committed to providing you with excellent service. If you find any missing parts, damaged packaging, or product damage after receiving all packages, please follow the steps below to quickly contact our customer service team. We will do our best to resolve your issue.

1. Missing Parts

Verify Parts:

1. Refer to the “Parts List” in the manual to verify the name, specifications, and quantity of the missing parts.
2. Take a clear photo of the parts list and mark the missing parts with detailed information, e.g., “Missing 5 pieces of M6x30mm screws.”

Contact Us:

- By Email:
 - Send an email to us, with the subject line “Missing Parts Issue.”
- A description of the missing parts and a photo of the parts list.
- Order details (order number, purchase platform, purchase date).

2. Product or Packaging Damage

If it affects normal use:

Steps:

1. Take clear photos or videos showing the damaged parts and the extent of the damage (multi-angle shots are recommended).
2. Email the photos/videos along with other details to us, with the subject line “Product Damage Issue.”

Resolution:

After verification, we will arrange for a replacement part, product exchange, or refund as quickly as possible.

If it does not affect normal use:

Steps:

1. Contact our customer service team.
2. Provide a description of the damage and include relevant photos or videos.

Resolution:

We will provide repair guidance or an appropriate compensation plan based on the specific situation.







Helpful Tips

To process your issue efficiently, please prepare the following information:







- Order details (order number, purchase platform, purchase date).
- Clear photos or videos.
- We are committed to providing quick and professional solutions, no matter the size of the issue, to ensure your satisfaction.

Thank you for your trust and support! We hope you enjoy using our product!

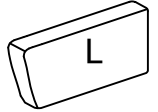
Hardware parts

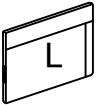
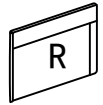
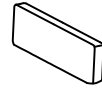
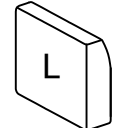
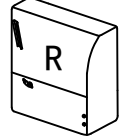
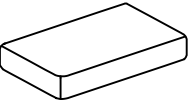
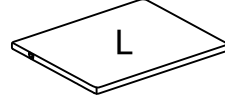
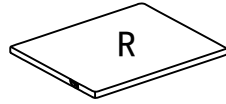
1 Sofa Wooden Leg 15cm  x4	2 Screw M6*30MM  M6*30MM x12	3 H Shape Angel Iron  x1	4 Screw M6*20MM  x12	5 V Shape Angle Iron  x1	6 Sofa Leg 15cm  x1	7 Allen Key M6  x1
---	--	--	---	--	--	---

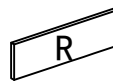
Main structure accessories

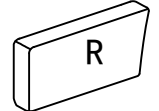
A Backrest (L)  x1	B Accent Pillows  x2	C Back Metal Frame (L)  x1	D Back Metal Frame (R)  x1	E Armrest Pillow  x2	F Armrest (L)  x1	G Armrest (R)  x1
H Seat Cushion  x2	I Seat Metal Base (L)  x1	J Seat Metal Base (R)  x1	K Seat Front Frame (L)  x1	L Seat Front Frame (R)  x1	M Seat Front Frame Cover  x1	N Backrest (R)  x1

STEP 1

Tear open the nylon fastener on the bottom of armrests G and F, then remove a total of 2 pieces of part B and 2 pieces of part E from inside the armrests.

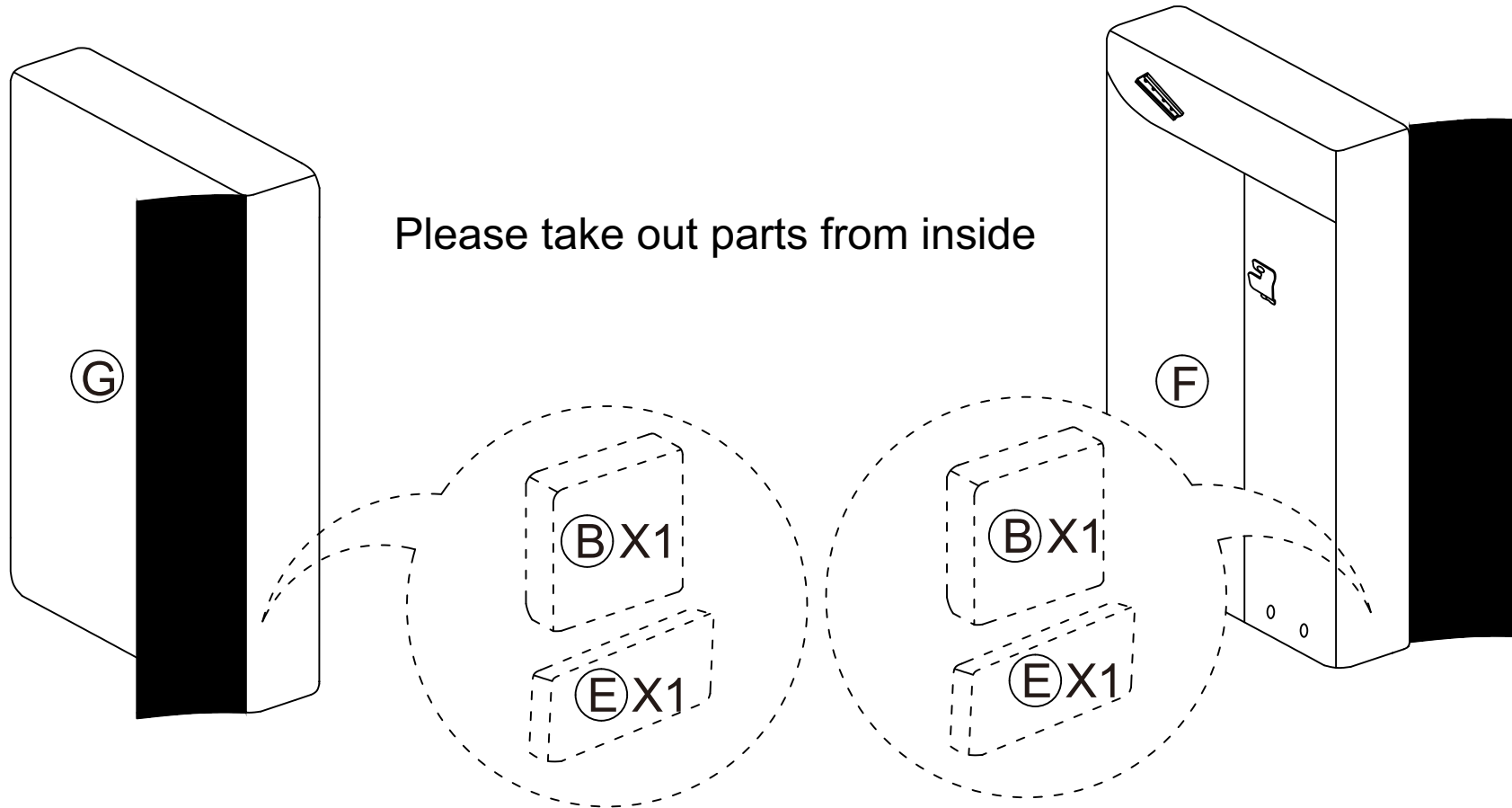



Note:

After taking out all the accessories, reattach the nylon fastener securely.

STEP 2

Attach the wooden legs (#1) to armrests G and F, and secure them using bolts (#2)

HARDWARE ACCESSORY LIST	
2	Screw M6*30MM
	
	x12
1	Sofa Wooden Leg 15CM
	
	x4

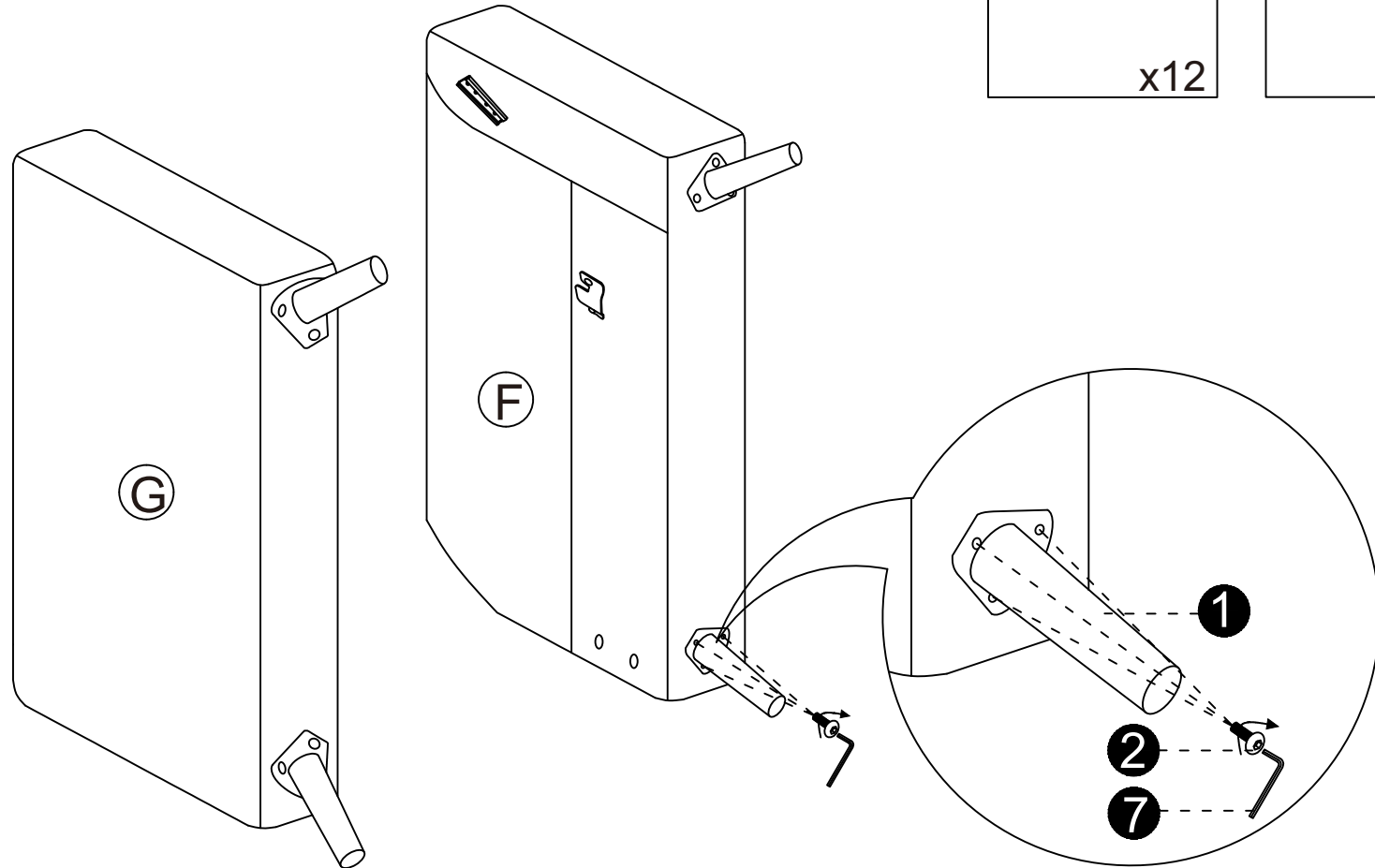



Note:

First, screw in all the bolts loosely, then fully tighten them once everything is in place. Make sure the legs are facing the correct direction.

STEP 3

HARDWARE ACCESSORY LIST

5 V Shape Angle Iron

x1

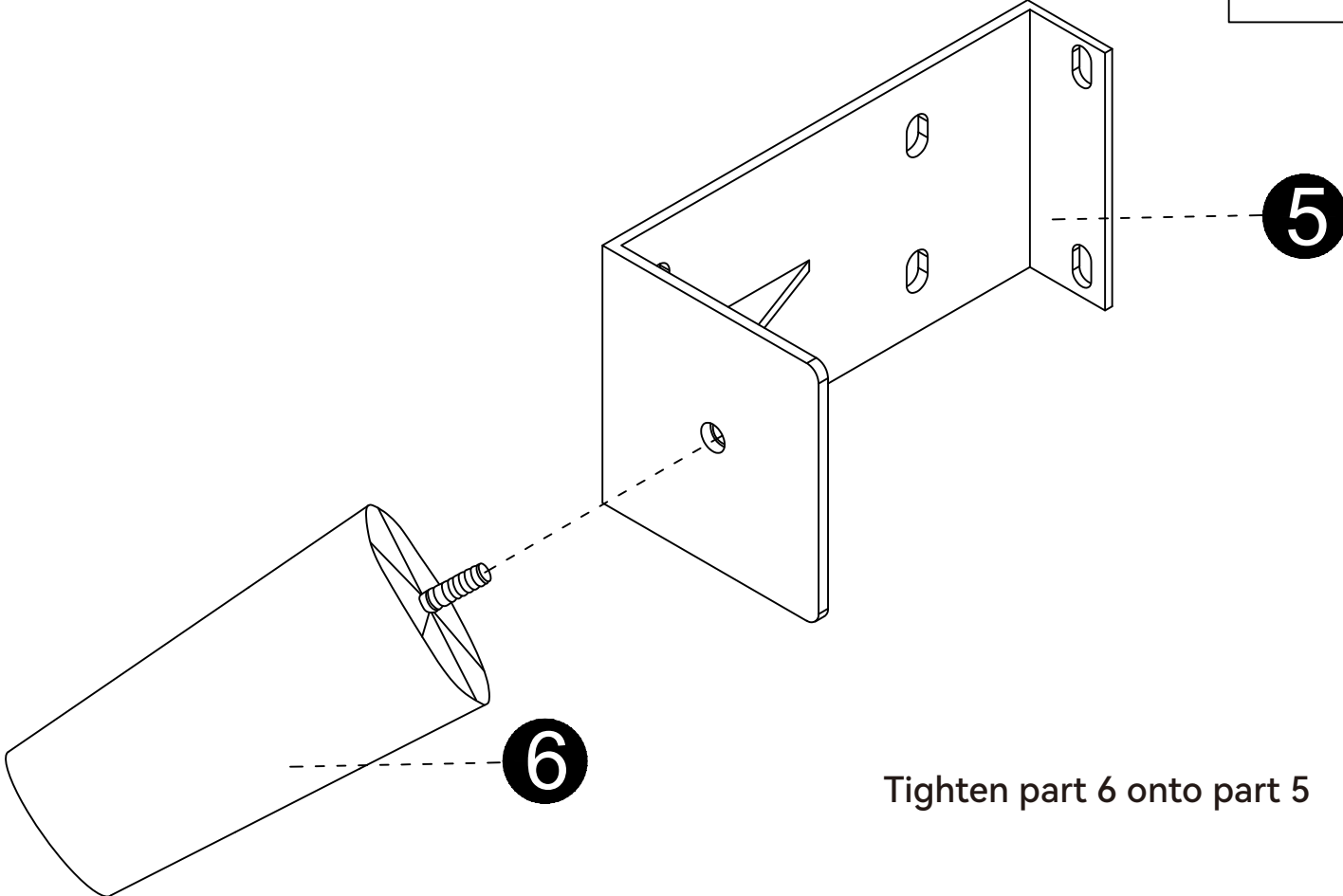
6 Plastic Middle Leg

x1



Tighten part 6 onto part 5

STEP 4

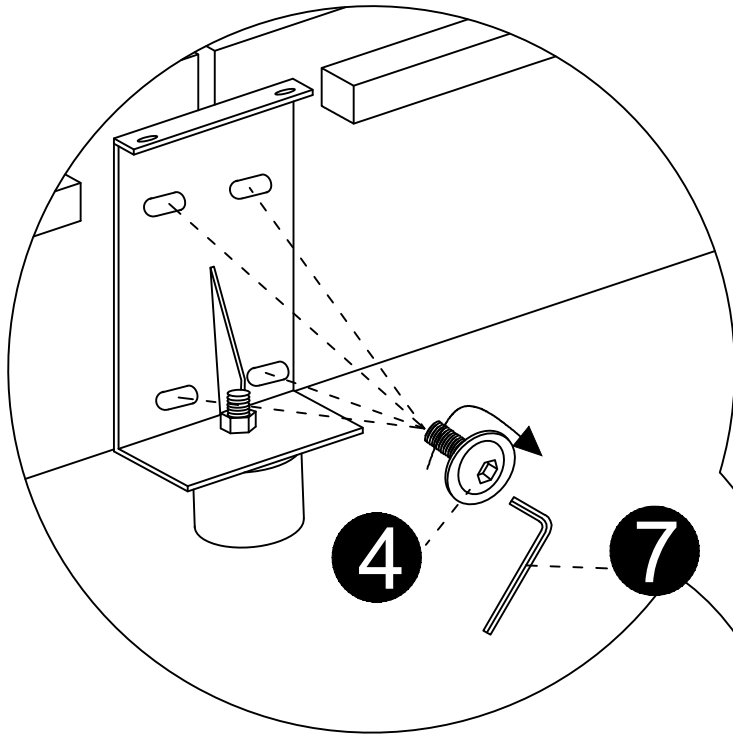
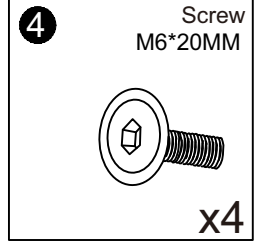
HARDWARE ACCESSORY LIST



Connect parts L and K using part 5, and secure them with bolts (#4).

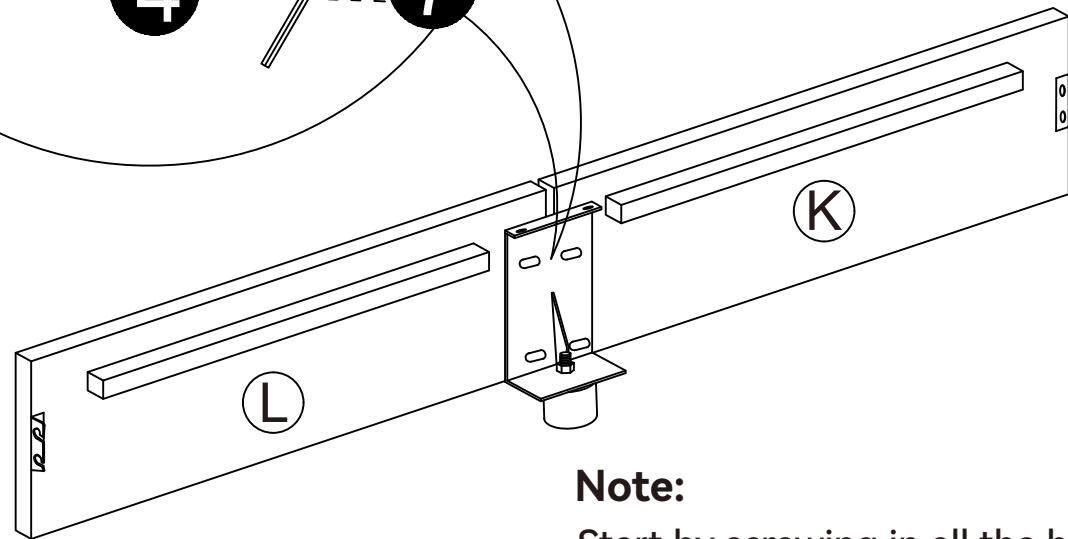

Note:

Start by screwing in all the bolts loosely. Once everything is aligned, fully tighten them.

STEP 5

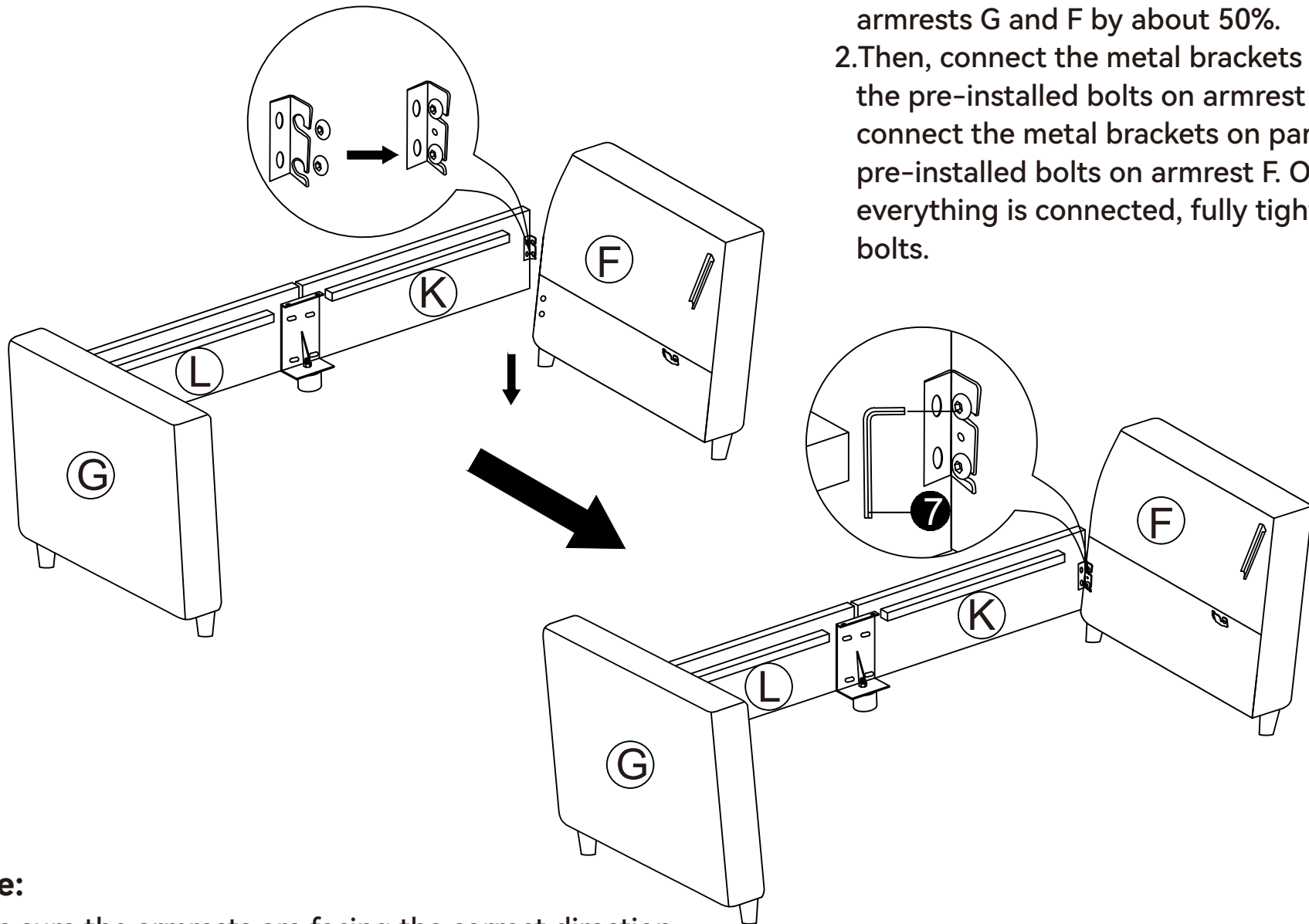

1. Loosen the pre-installed bolts on the front of armrests G and F by about 50%.
2. Then, connect the metal brackets on part L to the pre-installed bolts on armrest G, and connect the metal brackets on part K to the pre-installed bolts on armrest F. Once everything is connected, fully tighten all the bolts.

Note:

Make sure the armrests are facing the correct direction, front to back.

STEP 6

Insert the metal tabs on part I into the corresponding slots on armrest F.

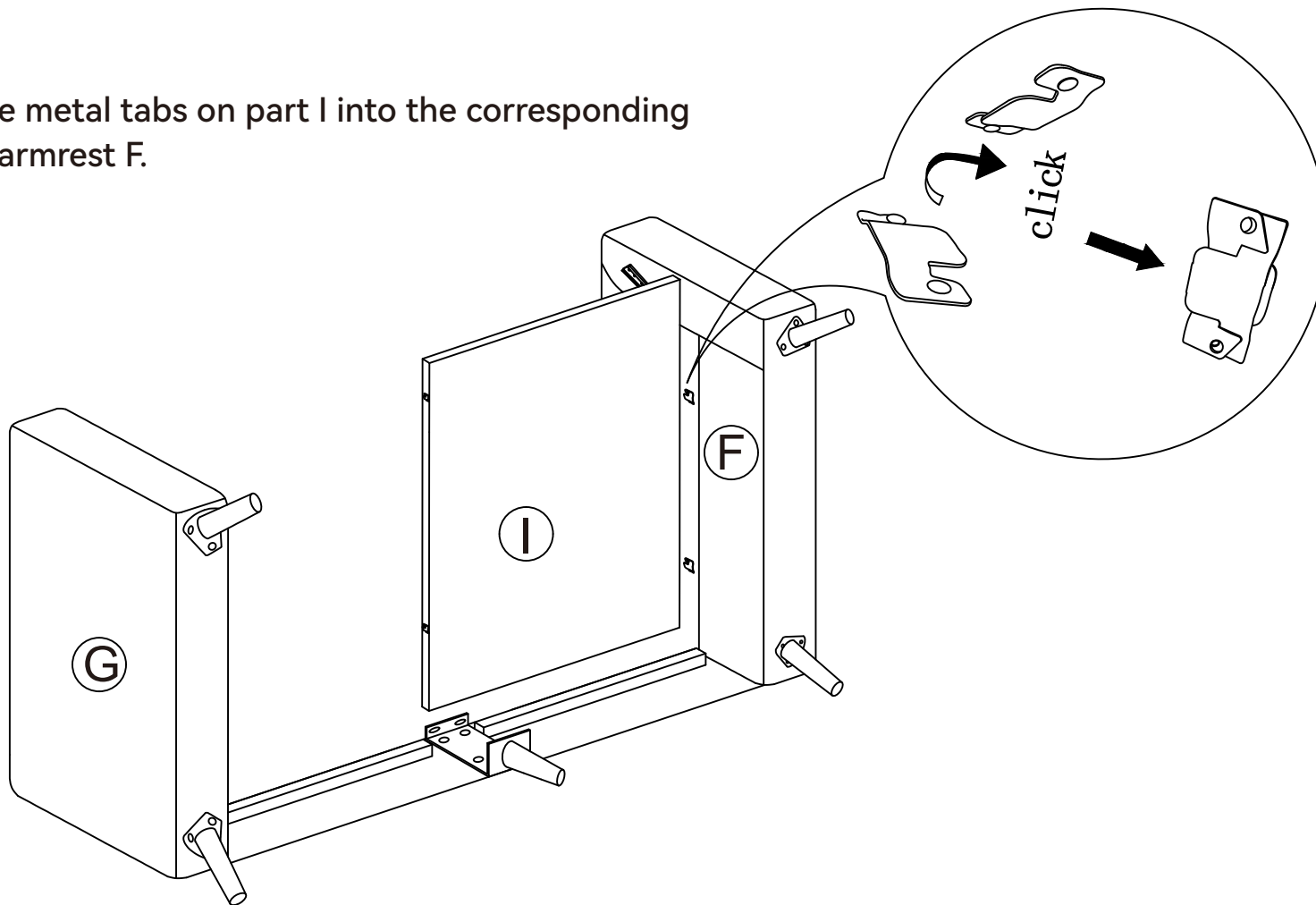

STEP 7

Insert the metal tabs on part J into the corresponding slots on armrest G and part I.

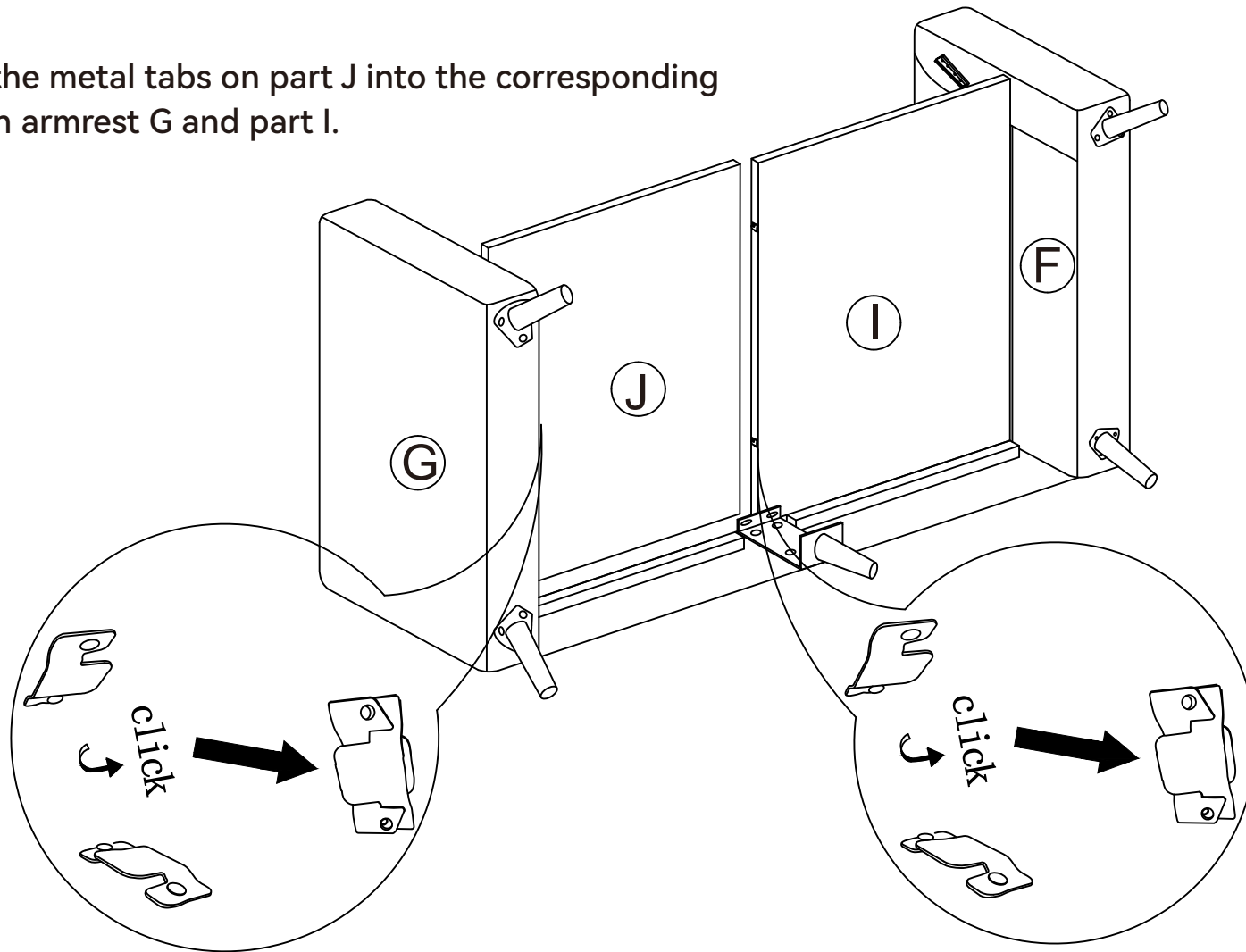

STEP 8

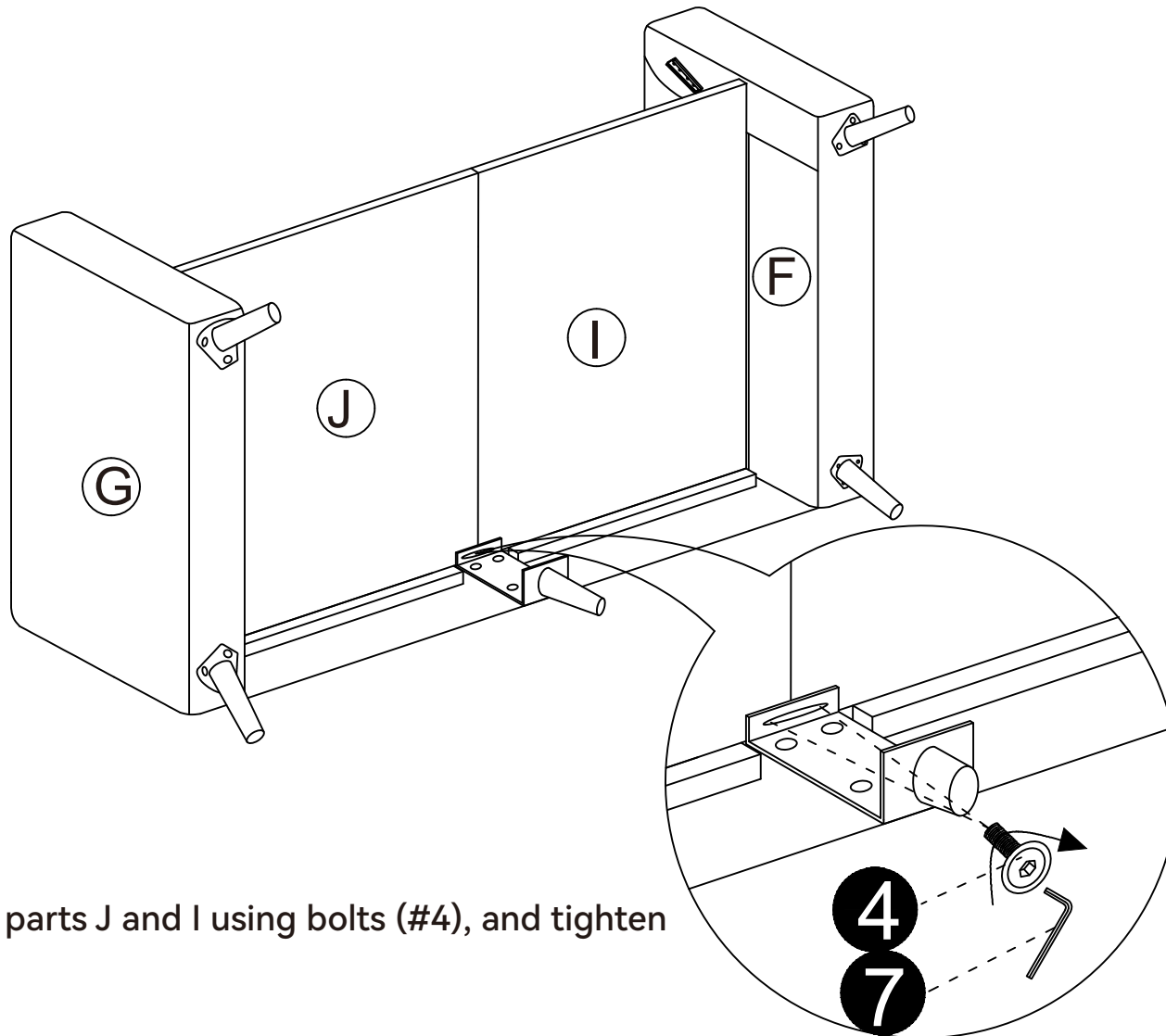
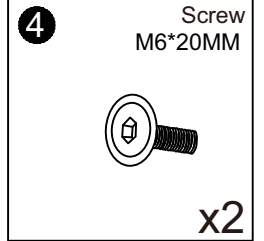

HARDWARE ACCESSORY LIST

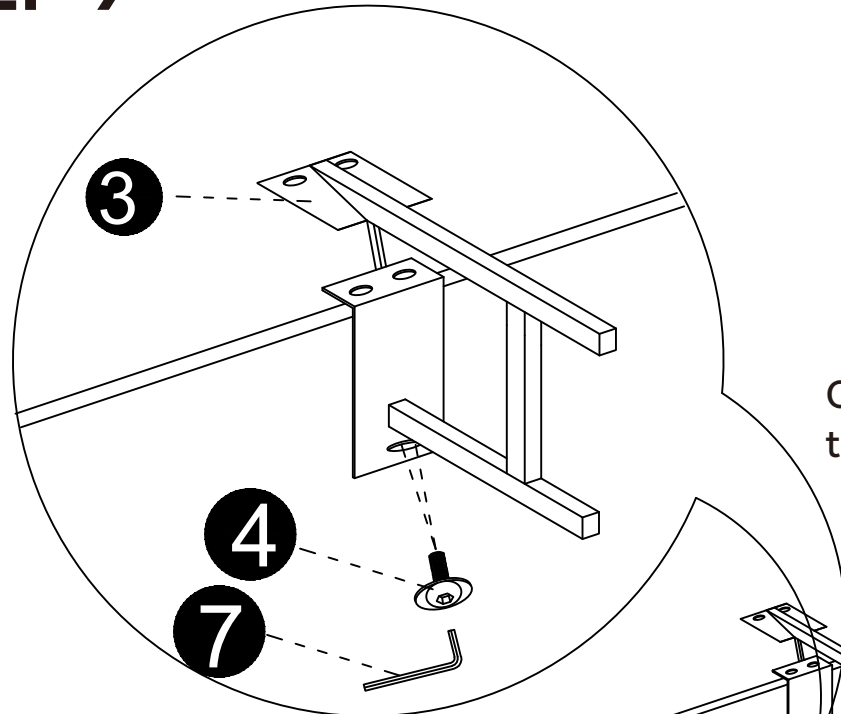

Secure part 7 to parts J and I using bolts (#4), and tighten the bolts.

STEP 9



HARDWARE ACCESSORY LIST	
4	Screw M6*20MM
	
	x2
3	H shape -angel iron
	

Connect parts J and I using hardware piece 3, and secure them with bolts (#4).

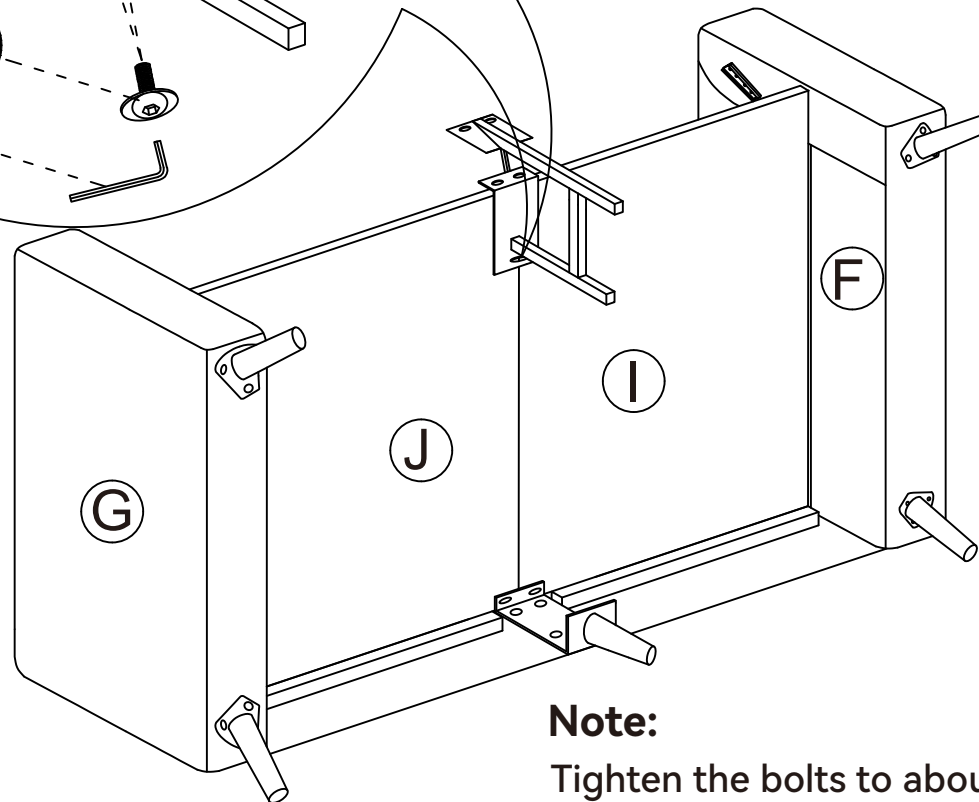

Note:

Tighten the bolts to about 70%—do not fully tighten them yet. This will make the remaining assembly easier.

STEP 10

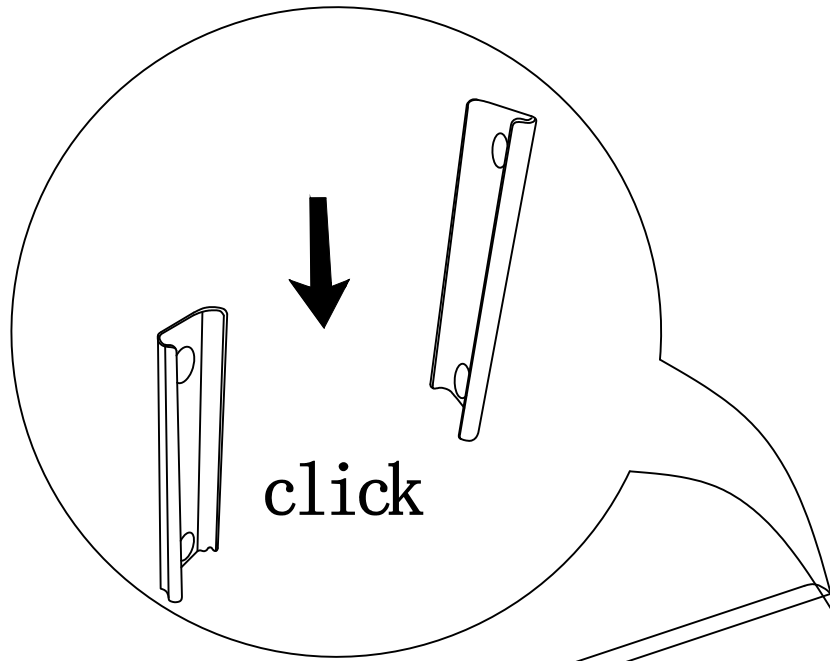

Connect parts C and D together.

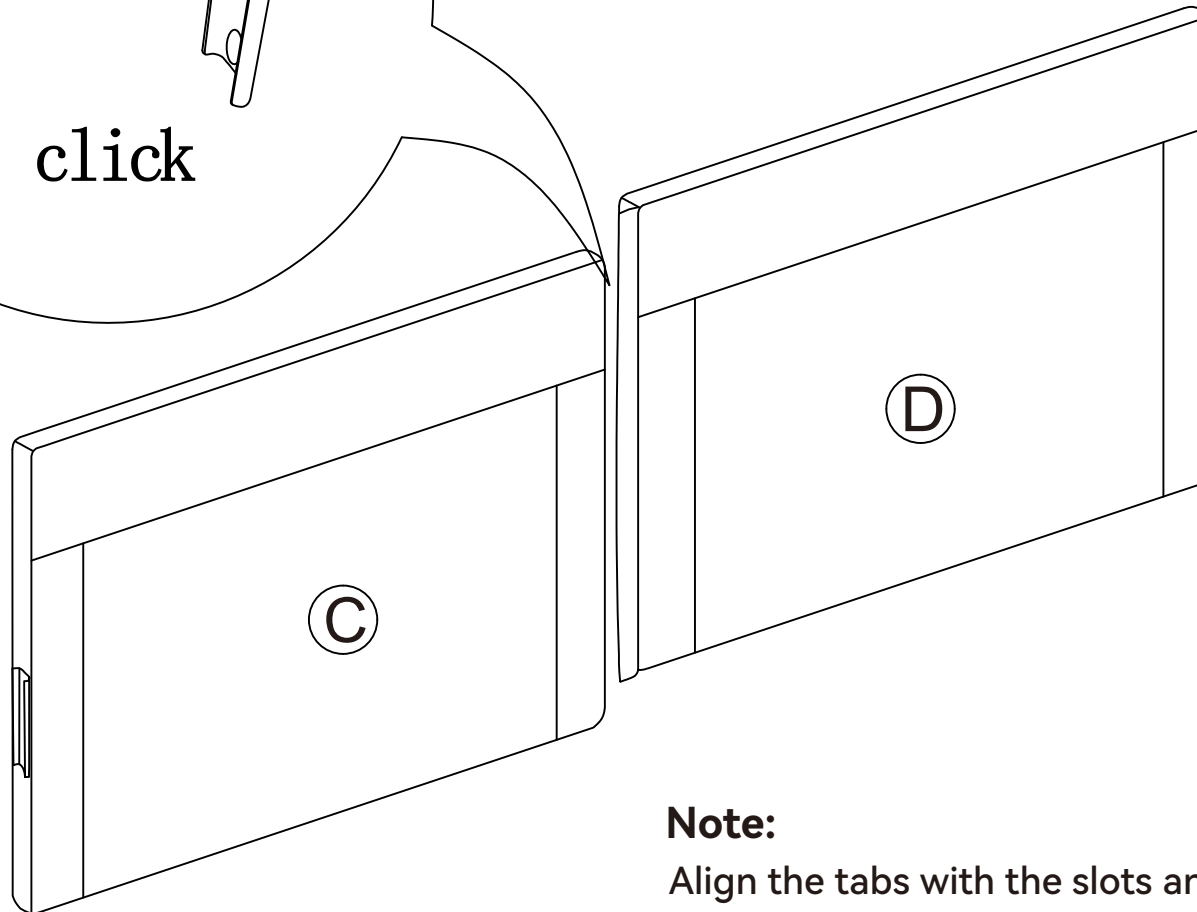

Note:

Align the tabs with the slots and push straight in with firm, even pressure until fully inserted.

STEP 11

Align the tabs on part C with the slots on armrest F, and the tabs on part D with the slots on armrest G. Push straight in with firm, even pressure until they are fully inserted.

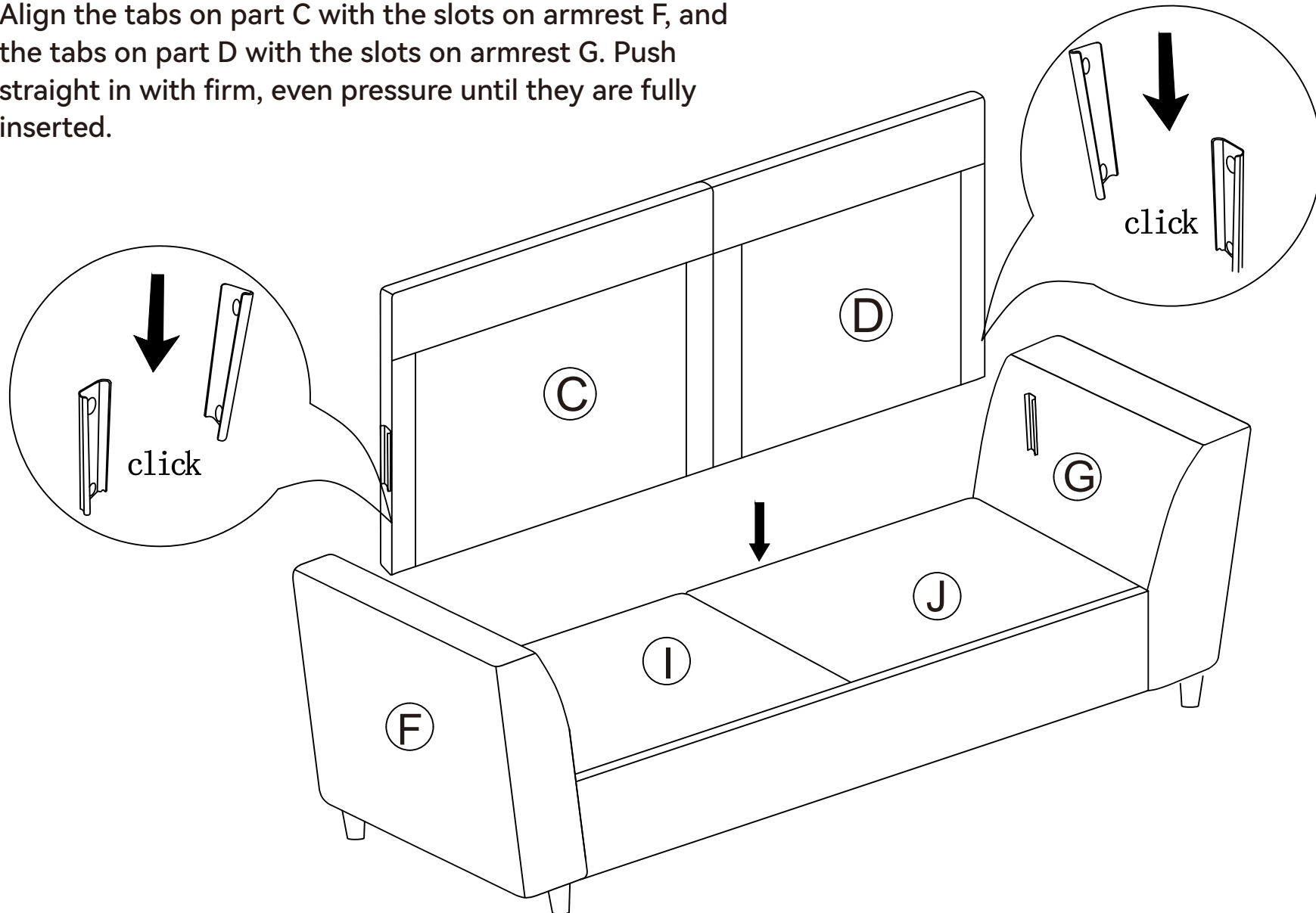

STEP 12

HARDWARE ACCESSORY LIST

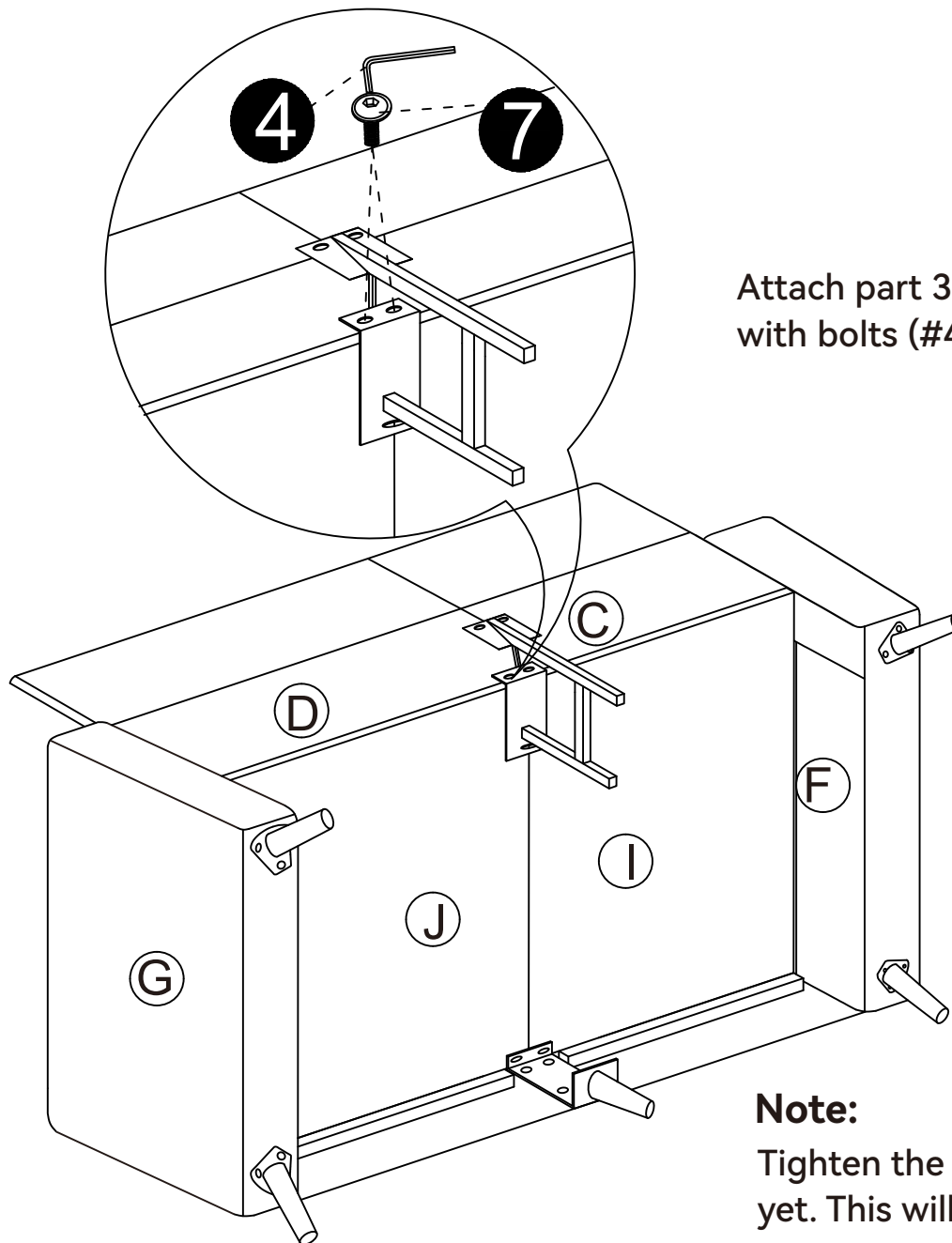
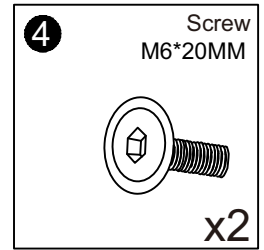

Attach part 3 to the holes on parts I and J, and secure it with bolts (#4).

Note:

Tighten the bolts to about 70%—do not fully tighten them yet. This will make the rest of the assembly easier.

STEP 13

HARDWARE ACCESSORY LIST

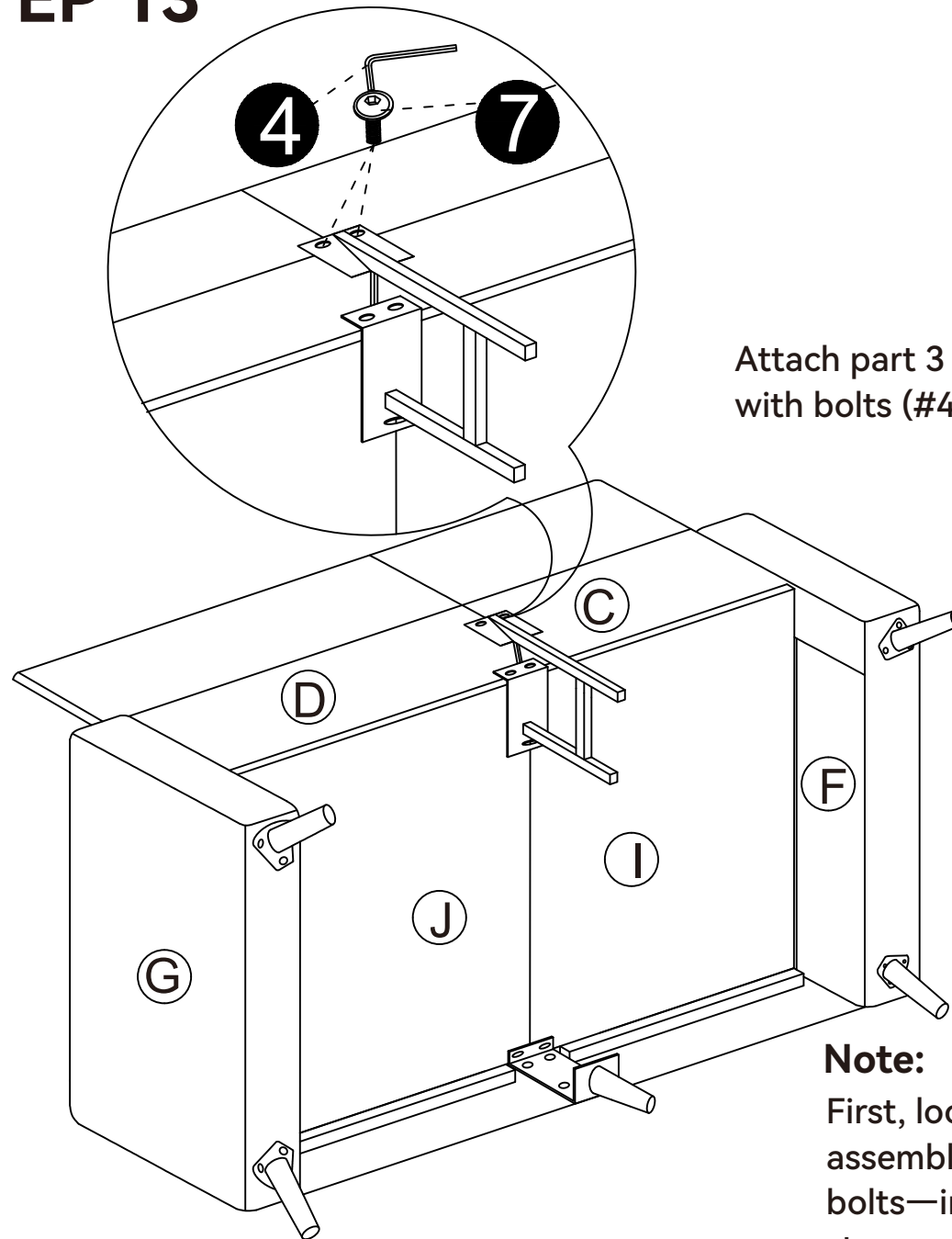
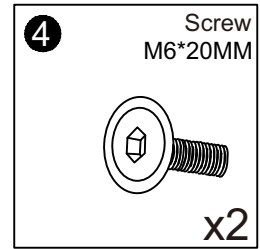

Attach part 3 to the holes on parts C and D, and secure it with bolts (#4).

Note:

First, loosely screw in all the bolts. Once everything is assembled and aligned, fully tighten all the bolts—including any that were left untightened in earlier steps.

STEP 14

Attach the fabric cover M to both parts L and K using the nylon fastener strips.

Using Nylon fastener to secure it in place

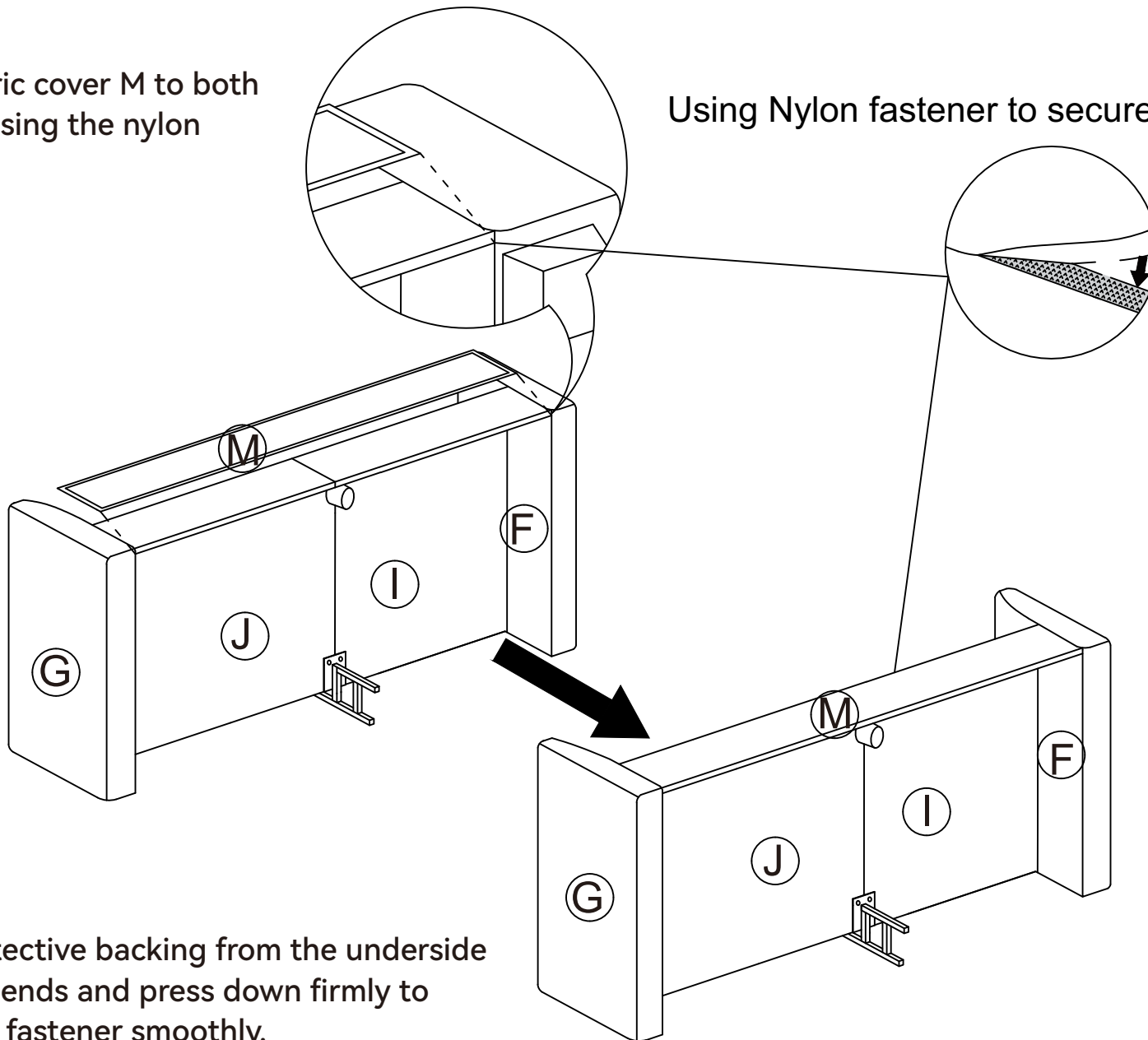

Note:

Remove the protective backing from the underside of M. Align both ends and press down firmly to attach the nylon fastener smoothly.

STEP 15

Place part H onto both parts I and J.

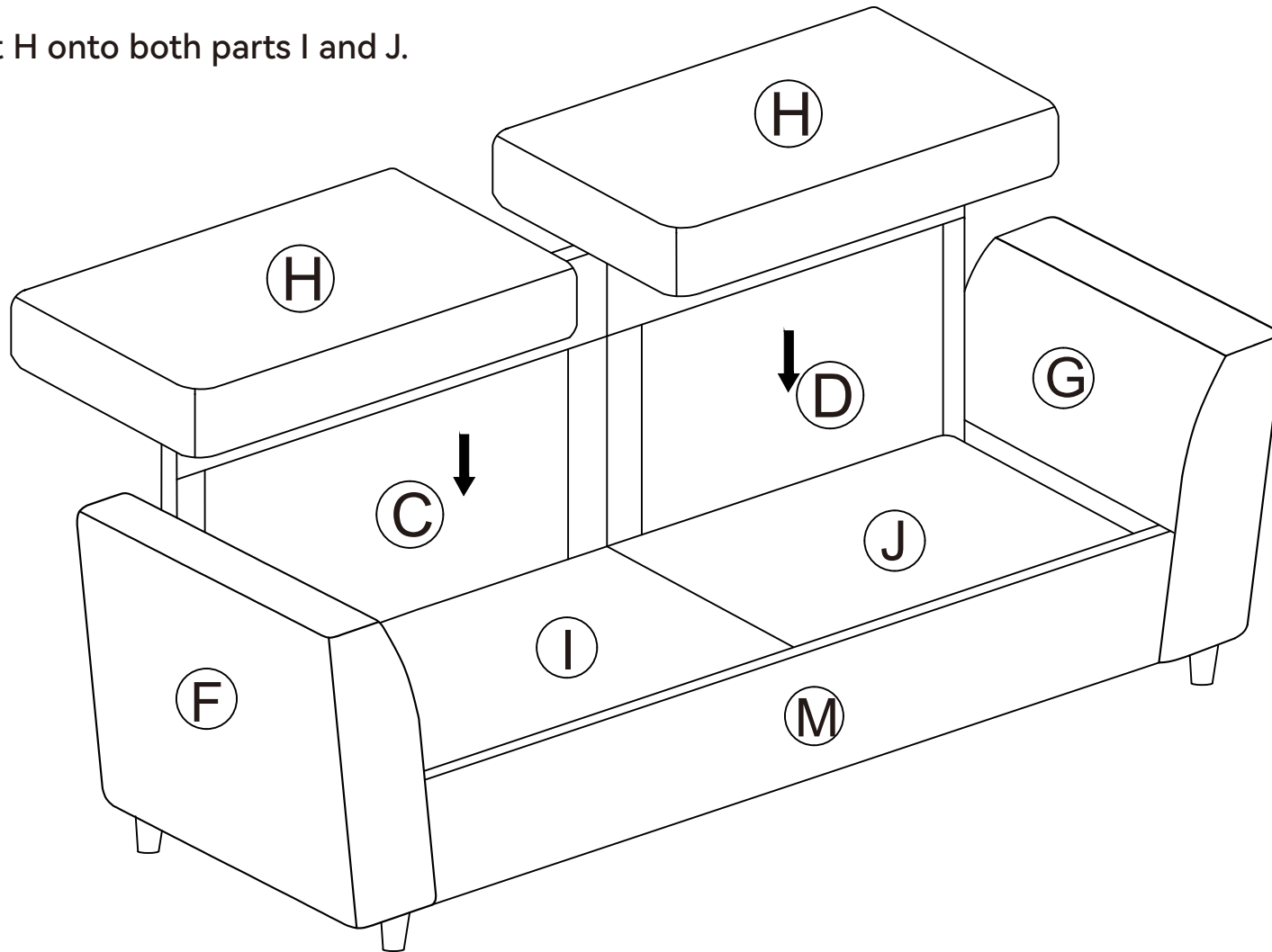

STEP 16

Place parts A and N on top of part H.

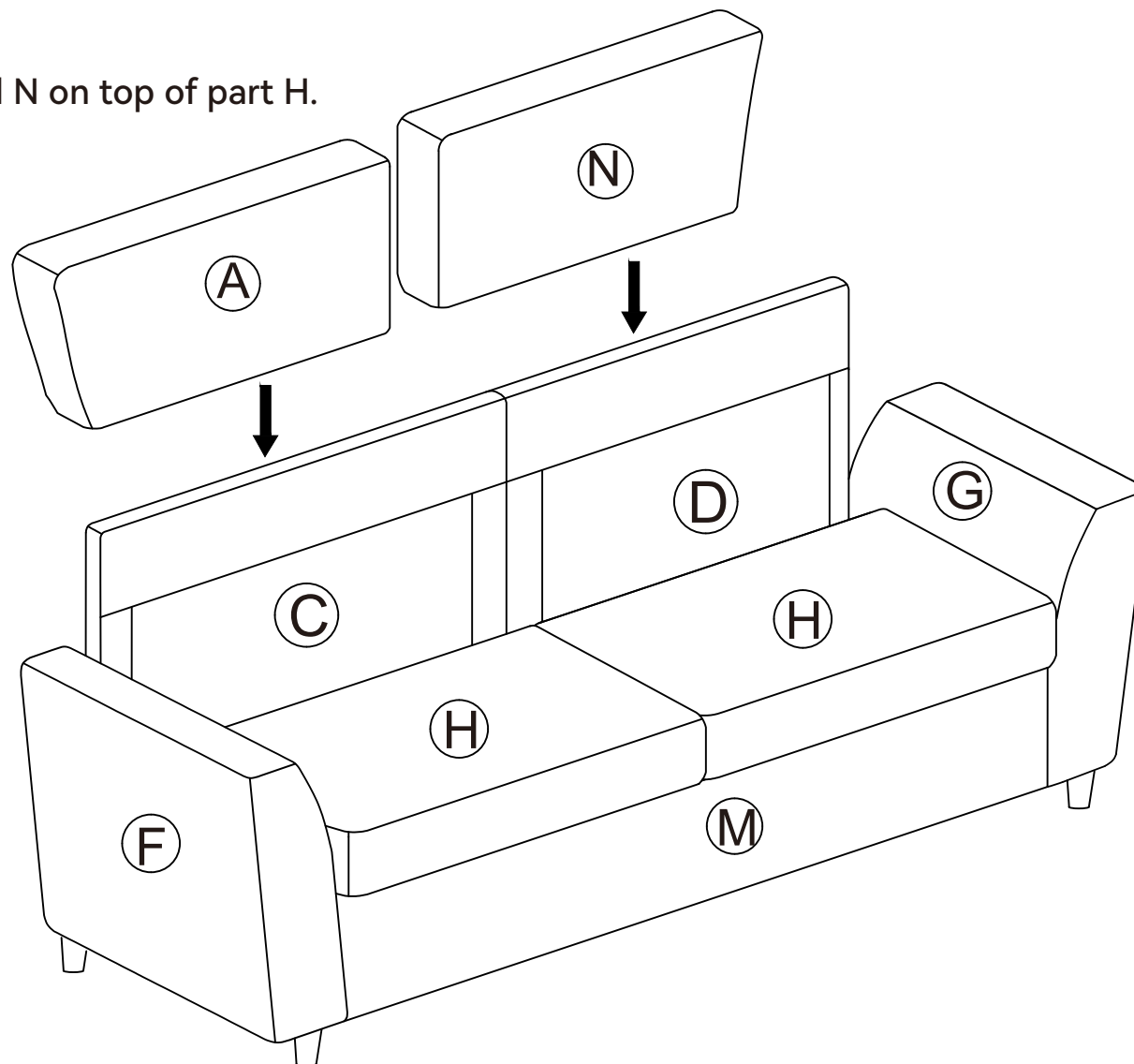

STEP 17

Place part B on top of part H.

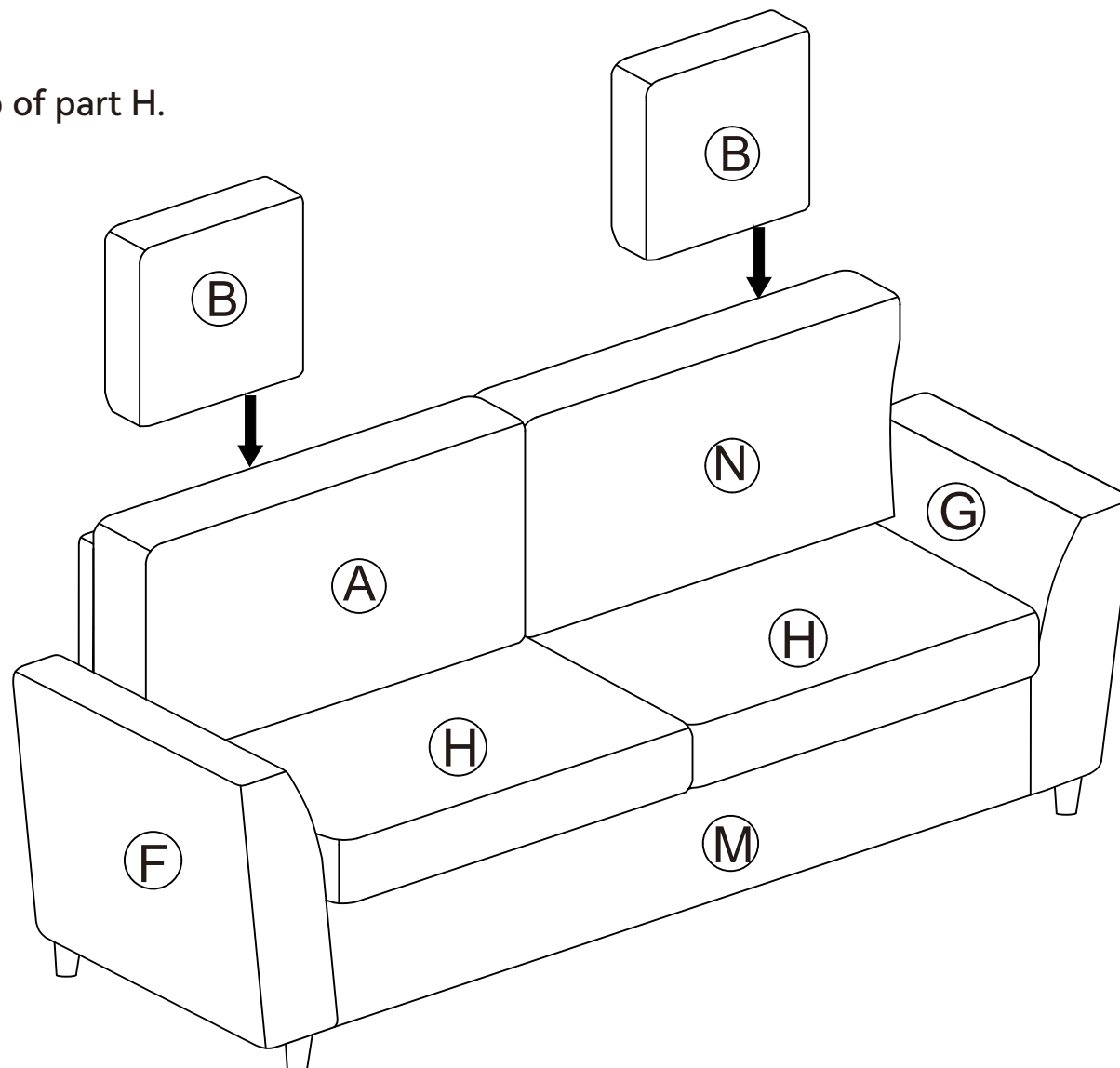

STEP 18

Place part E on top of part H.

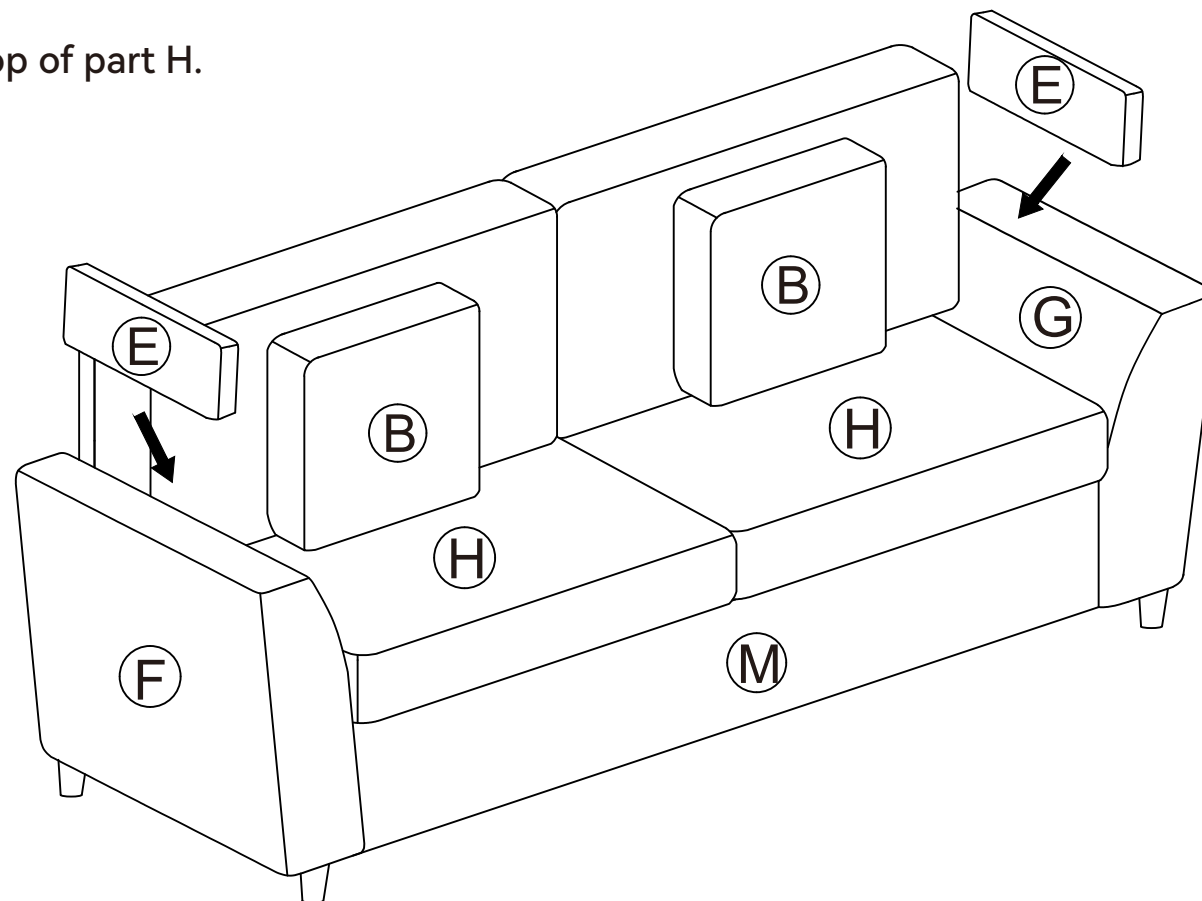

STEP 19

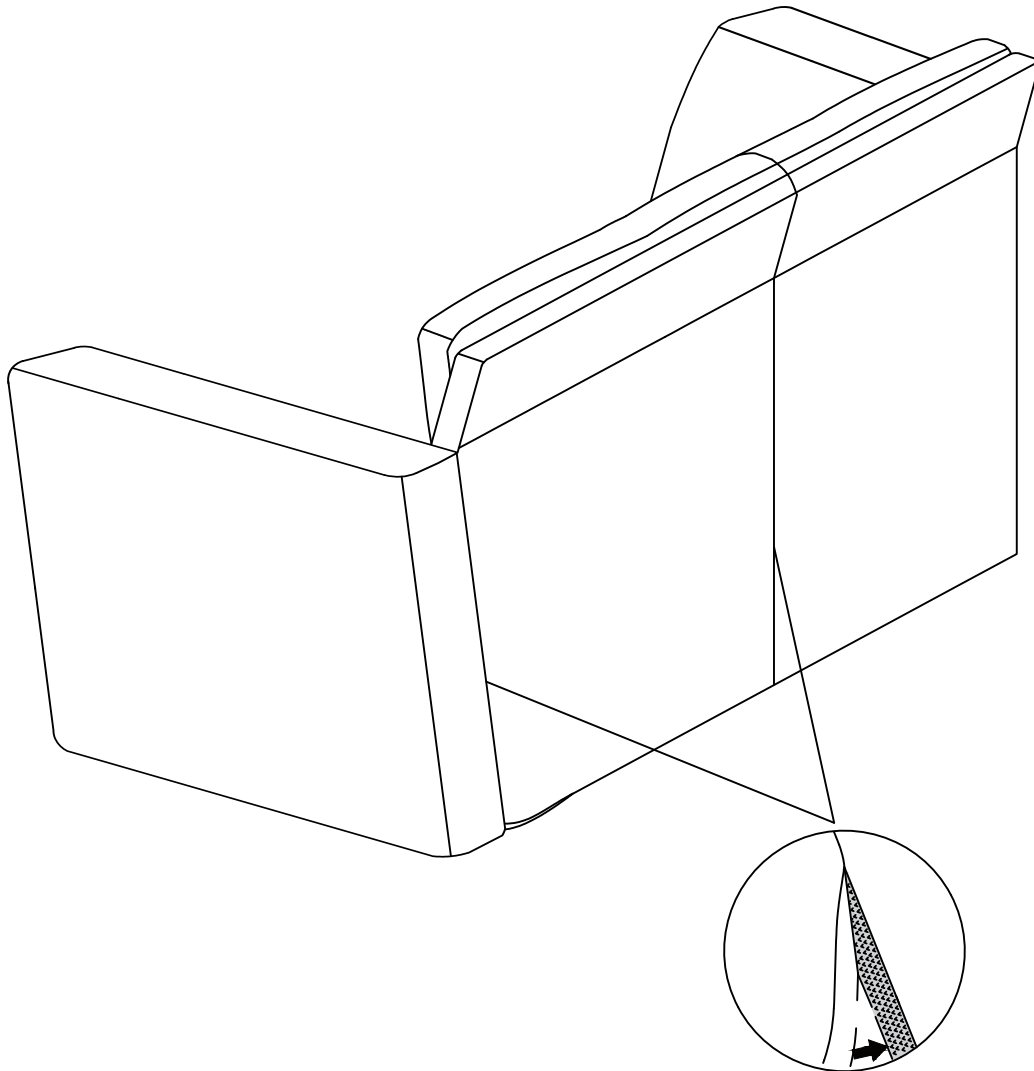

Remove the protective backing and press down the nylon fastener firmly for a smooth, secure attachment.

Using Nylon fastener to secure it in place

STEP 20

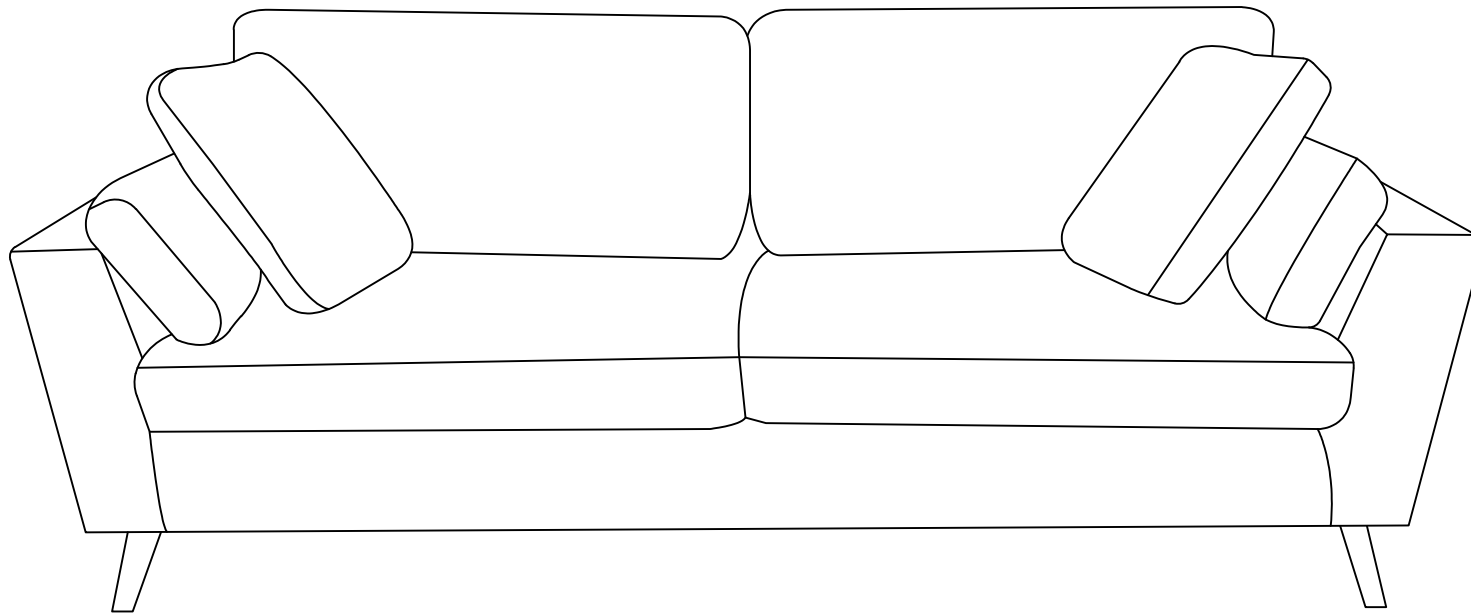

Assembly complete!