

## WARRANTY

We strive to offer high-quality products, and we also try our best to satisfy each and every customer that orders from us with product or service as needed.

Each customer must provide a record of their order such as the order number, or item receipt for any items that are out of the warranty period you may also still receive replacement parts by purchasing them with our company if they are available.

**Are you having difficulty  
with assembly? Missing parts?**

**Please contact us : [info@firstopintl.com](mailto:info@firstopintl.com)**

**telephone No.:5627813327**

**send email with your order No. to**

**For return, please check the return policy with  
the retailer or market place you bought from.**

**Appreciate your purchasing from us.**

**Pop up your life by our furniture !**

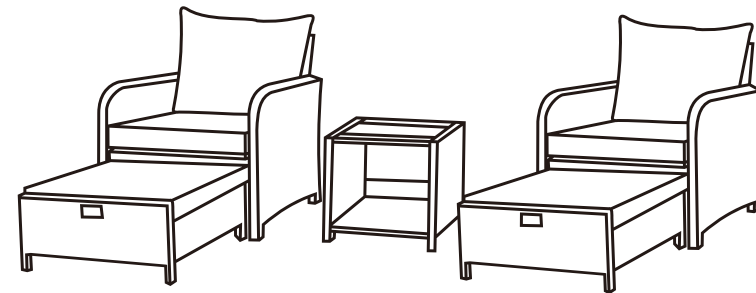
The logo for Wixe, featuring the word "wixe" in a bold, lowercase, sans-serif font. The letter "i" is stylized with a leaf-like shape above it.

ITEM NO: FOP-ODF518882801

ITEM NO: FOP-ODF518882802

ITEM NO: FOP-ODF518882803

ITEM NO: FOP-ODF518882901

ITEM NO: FOP-ODF518882902

ITEM NO: FOP-ODF518882903

### NOTE:

This brochure contains IMPORTANT safety info. Please read and keep for future reference.

# MAINTAINANCE AND WARNING







- Keep furniture away from heat and fire.
- Keep furniture away from sharp objects.
- Do not clean furniture with harsh cleansers or polish. Do not use detergents, Solvents, abrasives, spray packs or leather cleaner. Use non-color mild soap with warm water clean spills(Mix 1:10 soap to water)
- Do not jump or strike on the furniture.
- Do not write on furniture without a padded barrier to protect the surface.
- Not for commercial use, For residential use only.

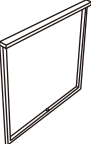
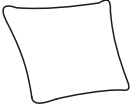

Weight Limitation

**250LBS**

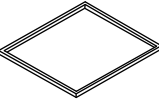
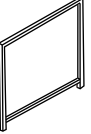
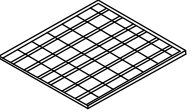
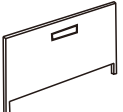
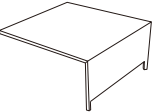
# PARTS LIST

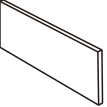
A*2  Armrest	B*2  Armrest	C*2  Backrest
D*2  Seat surface	E*2  Pillows	F*2  Seat Cushion
G*1  Table	H*2  Side panel	I*1  Storage plate
J*2  parts	K*2  L-parts	L*2  Seat Cushion
M*4  Side panel		

# HARDWARE and TOOL LIST

①\*18  
M6\*35mm

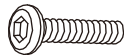

Bolt

②\*24  
M6\*30mm

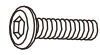

Bolt

③\*42  
M6



Gasket

④\*1  
M6



Allen Key

## SPARE

①\*1  
M6\*35mm



Bolt

②\*1  
M6\*30mm

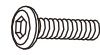

Bolt

Be sure to check all packing materia fit the packing list. Carefully for small parts, which may have come loose inside the carton during shipment.

# ASSEMBLY INSTRUCTIONS

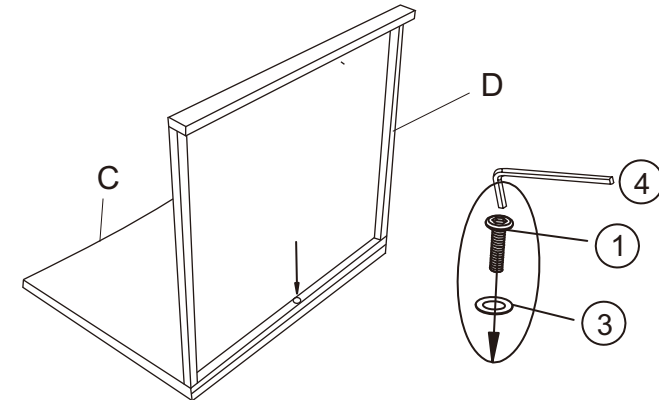

**STEP 1:** Screw ① with gasket ③, using the allen key tool to assemble the backrest C and seat surface D.

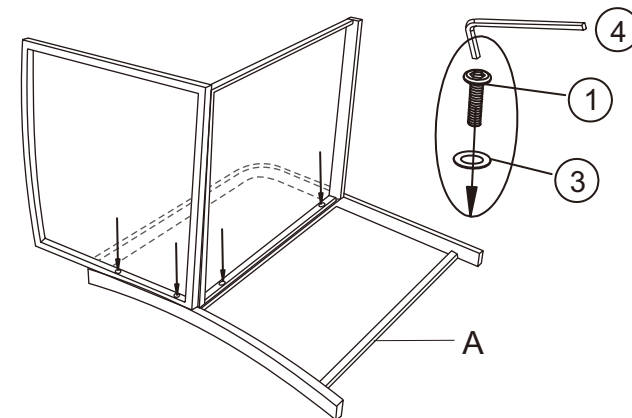

**STEP 2:** Put the armrest A on a clean surface, align the reserved screw holes on the backrest C and seat surface D with the reserved screw holes on the armrest A, use the screw ① with the gasket ③, and assemble the armrest with them with the help of the allen key tool ④.

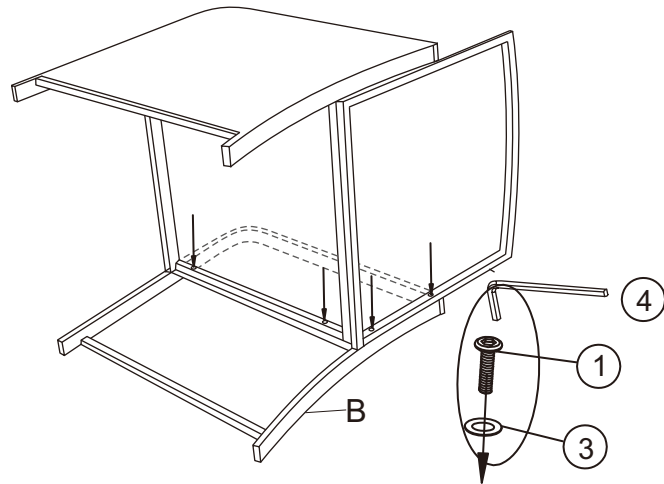

**STEP 3:** As in the previous step, assemble the other armrest.

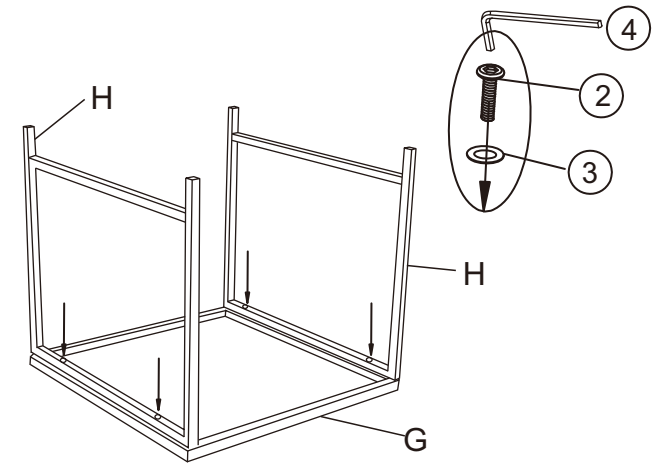

**STEP 1:** Place the bottom of the table G upward on a clean surface, align the screw holes reserved on the side panel H(2PCS) with the screw holes reserved on the table G, and use gasket (3) on the screw (2) to assemble the two. This process requires the use of the hex tool (4).

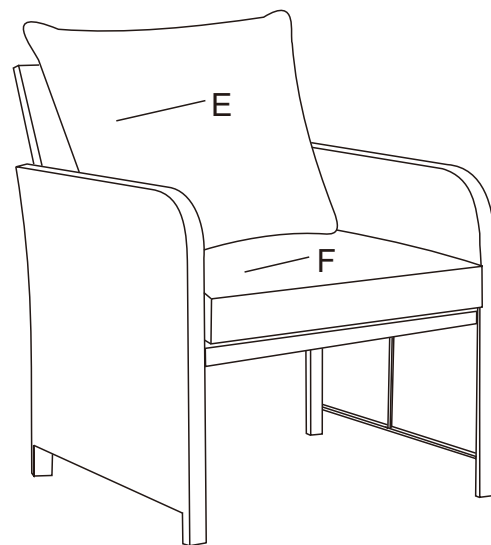

**STEP 4:** Using the hex tool, tighten all screws until they are completely tightened. Place seat cushions and pillows, and arrange them to make them beautiful. Using the allen key tool, tighten all screws until fully secured. Assembly completed.

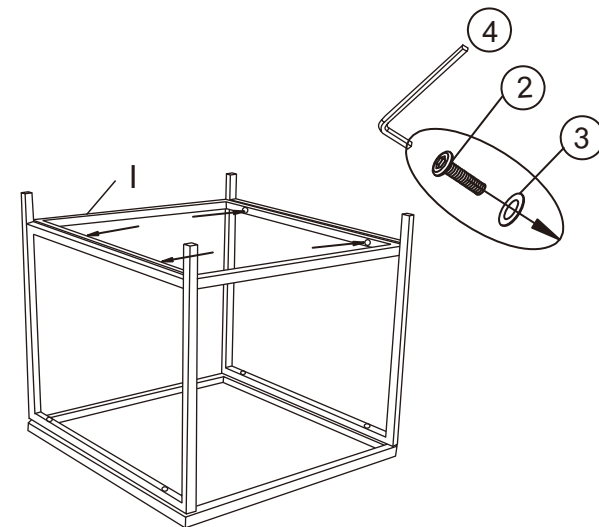

**STEP 2:** Align the holes reserved on both sides of the coffee table storage plate I with the holes reserved on the side plates on both sides of the coffee table, add gasket (3) on the screw (2) and assemble the storage plate I with the help of the allen key (4).

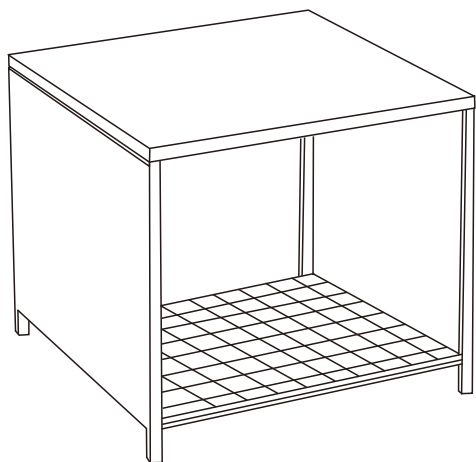

**STEP 3:** Using the allen key tool, tighten all screws until fully secured. Assembly completed.

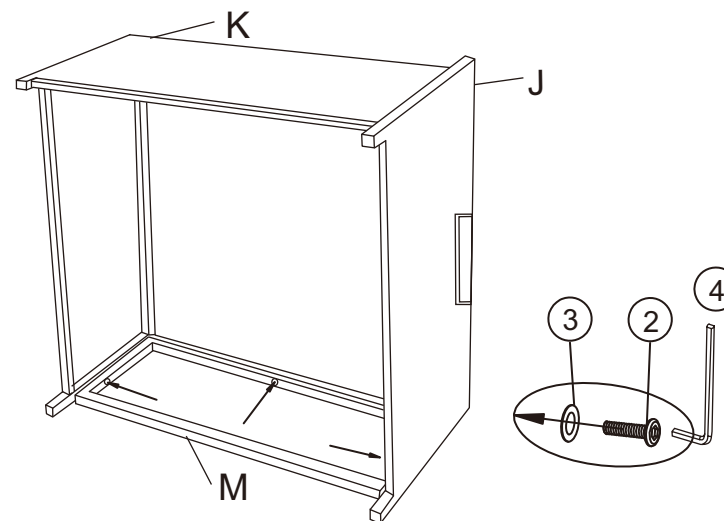

**STEP 2:** Assemble the other part M in the same way.

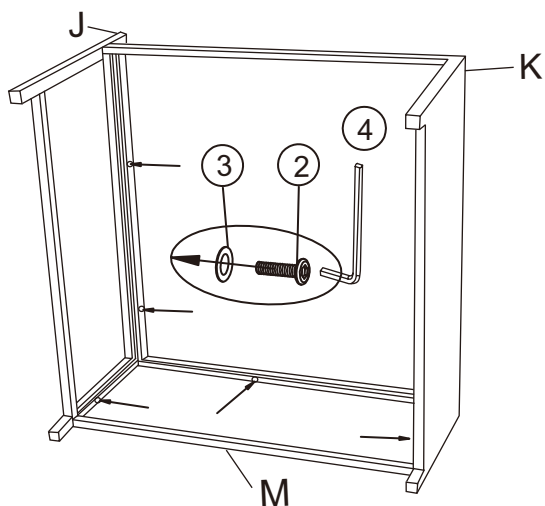

**STEP 1:** According to the instructions, add gasket ③ on the screw ② and assemble the parts J and K. Then assemble the part M in the position shown in the same way.

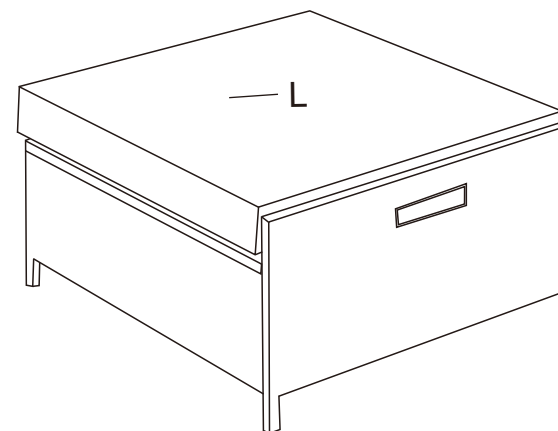

**STEP 3:** Place the seat cushion L on the stool and arrange it to make it beautiful. Use the allen key ④ to tighten all screws until fully secured. Assembly completed.