

BREATHING LEATHER SINGLE MOTOR ELDERLY CHAIR

USAGE GUIDELINES

(To use this product, please read this User Guide carefully)

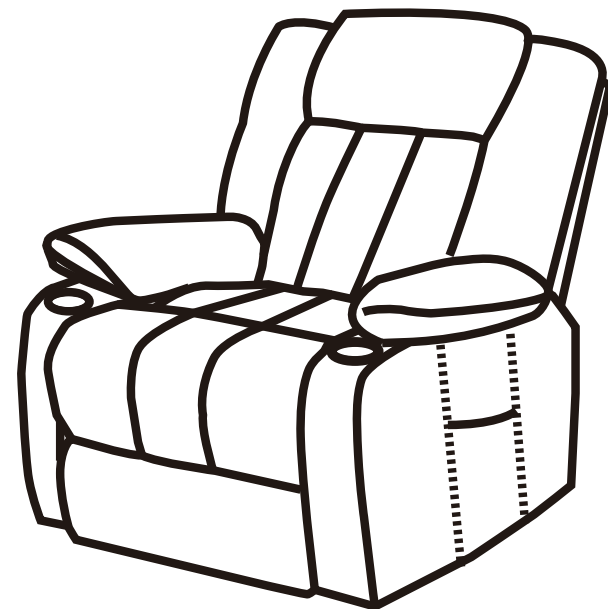

CATALOGS

Dear friends.

Thank you for using our products, in order to facilitate your correct operation of this product, please read this user guide carefully before use, and store it in a fixed place so that you can consult it in the future.

Basic Product Parameters -----	01
Unpacking List -----	01
Installation instructions -----	03
Function Introduction -----	07
Transport and installation -----	12
Caveat -----	12
Methods of care -----	13

BASIC PRODUCT PARAMETERS

BRAND NAME POWER LIFT CHAIR

SIZES 97*96*107CM

UNPACKING LIST

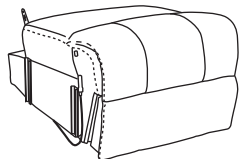
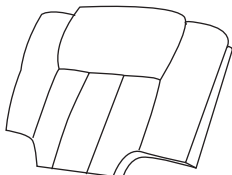
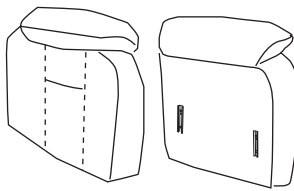
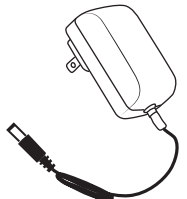
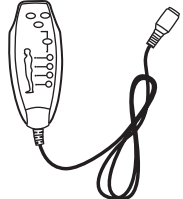
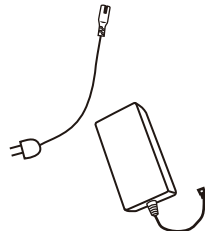
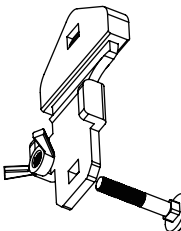
			
Chair base	Backrest	Left and right armrest	
			
Power cord	Remote control	Power Source	Anti-fall bracket x2

INSTALLATION INSTRUCTIONS

step1

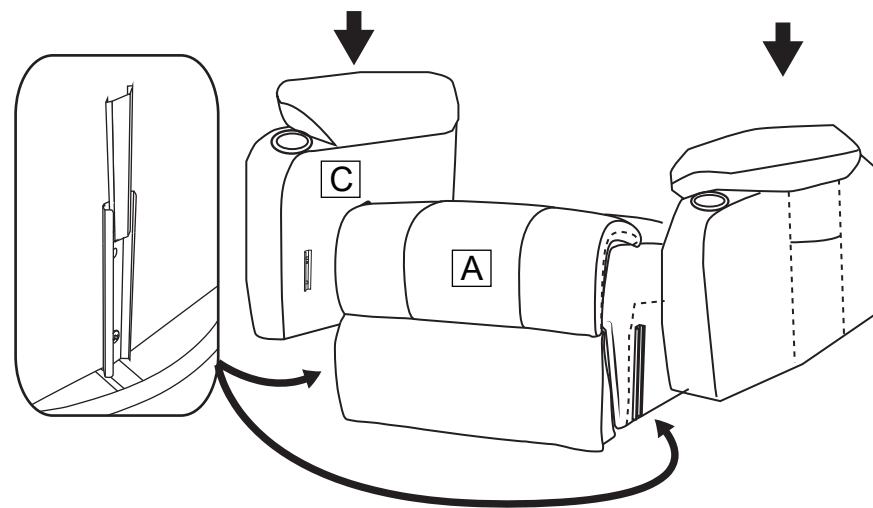

Insert two armrests to the chair base, make sure the slots on the armrests fully assembled to the bottom part.

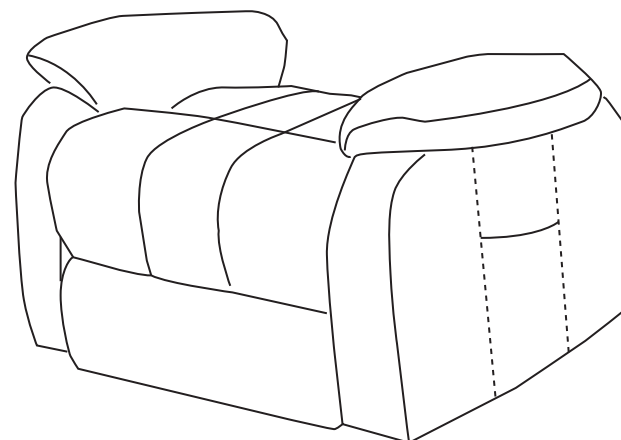

INSTALLATION INSTRUCTIONS

step3

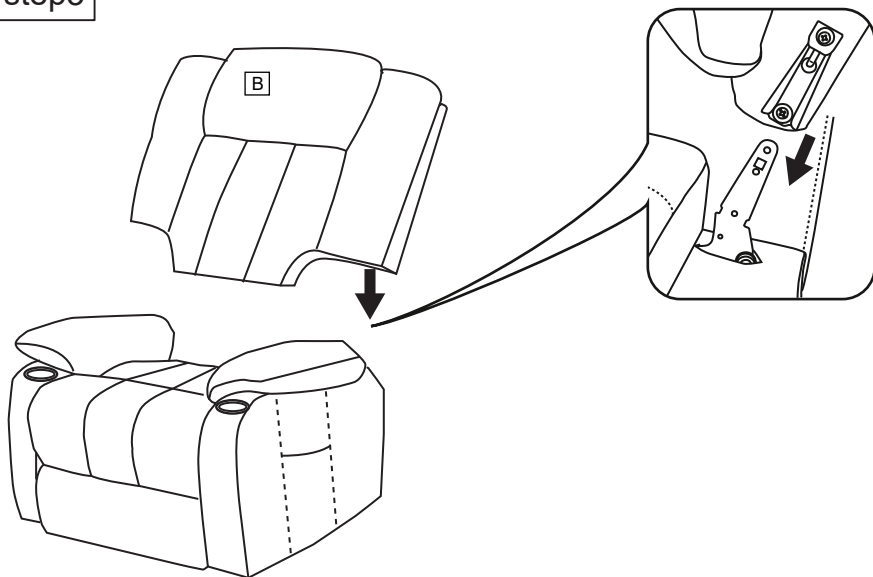

Insert chair back to the chair base, make sure the slots on the back fully assembled to the bottom part.

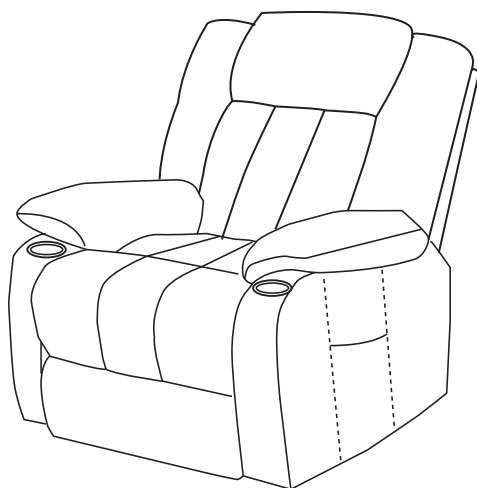

INSTALLATION INSTRUCTIONS

step5

No.1 and No.2 wire connect with the backrest and chair base.

No.3 wire connects with backrest and power cord(D).

No.4 wire connects with backrest and remote control(E).

No.5 wire connect the motor and the wire from rightside armrest,which use to connect the control panel.

No.6 wire connect the motor and power source (F).

NOTE

1: Two same color wires connect.

2: Plug power cord and power source into outlet, then you can use all function.

How to recline?

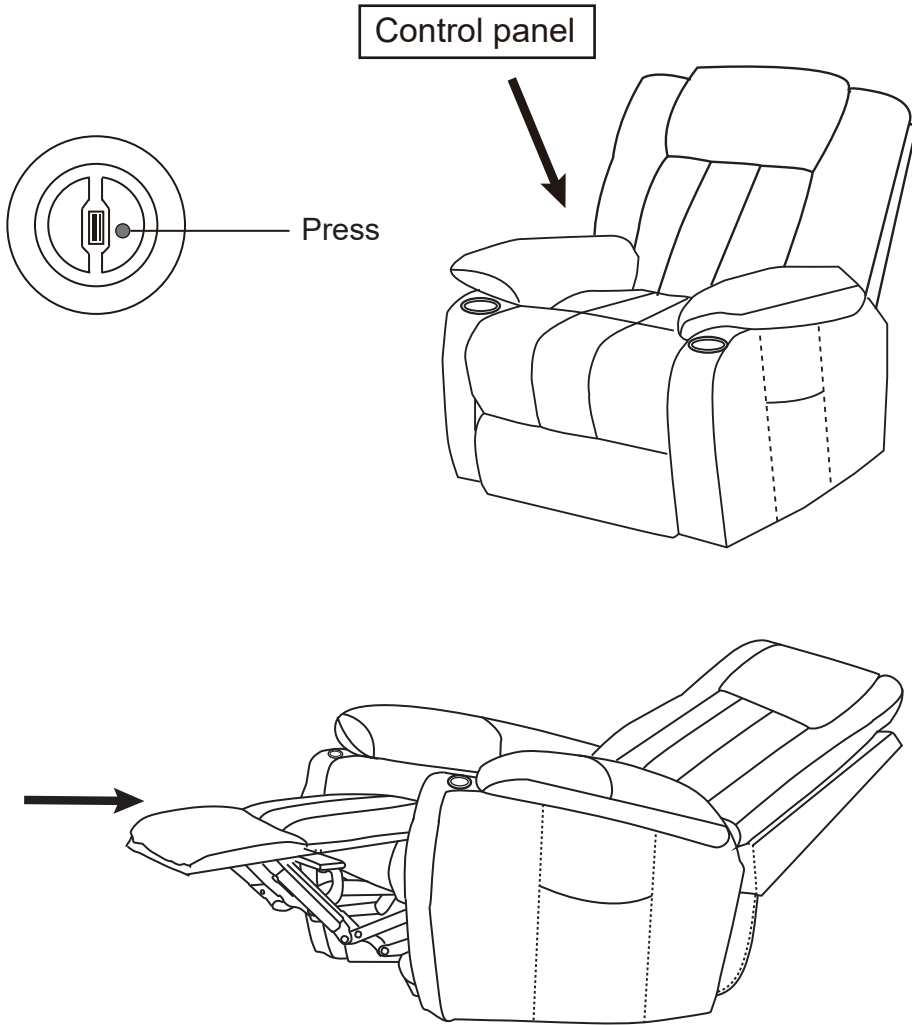

How to get footrest latch down and stand?

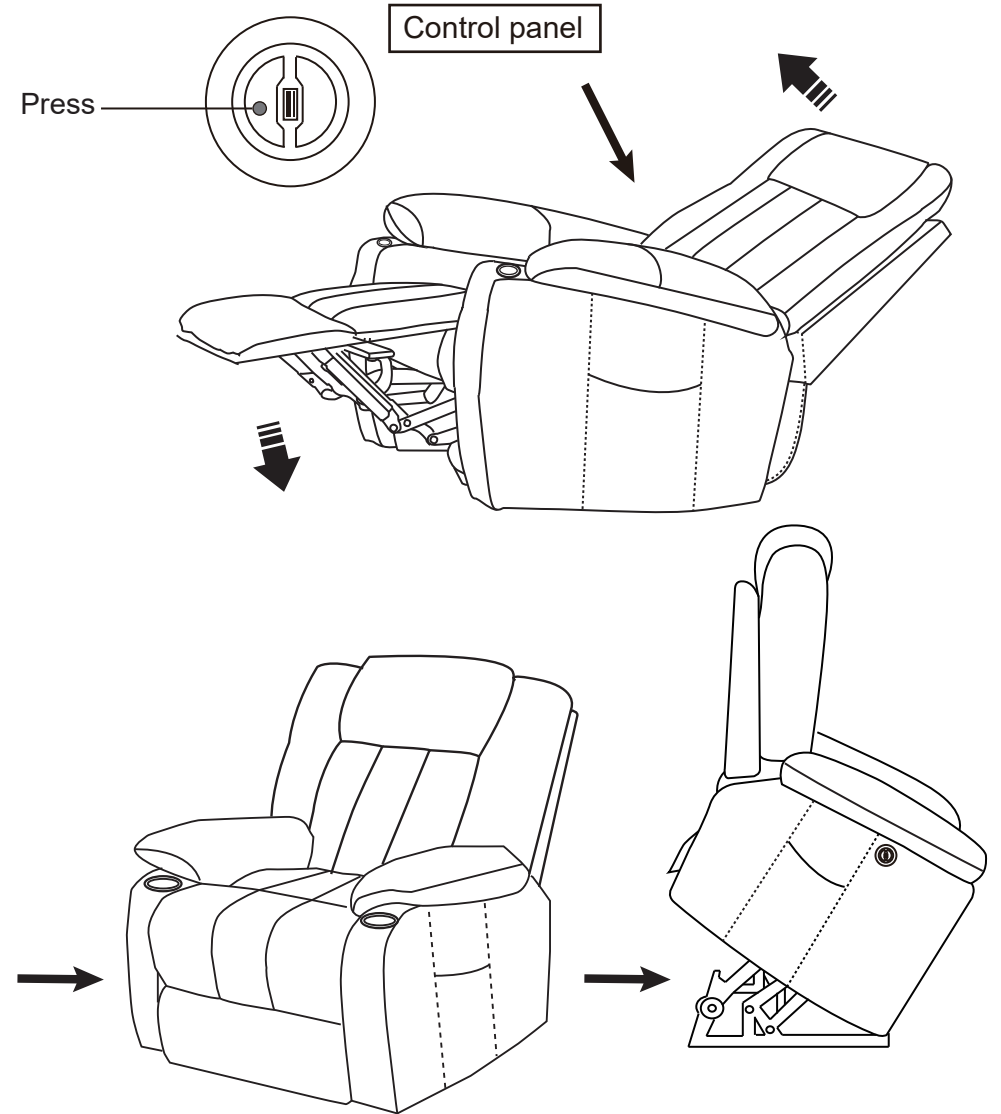

How to use the remote control?

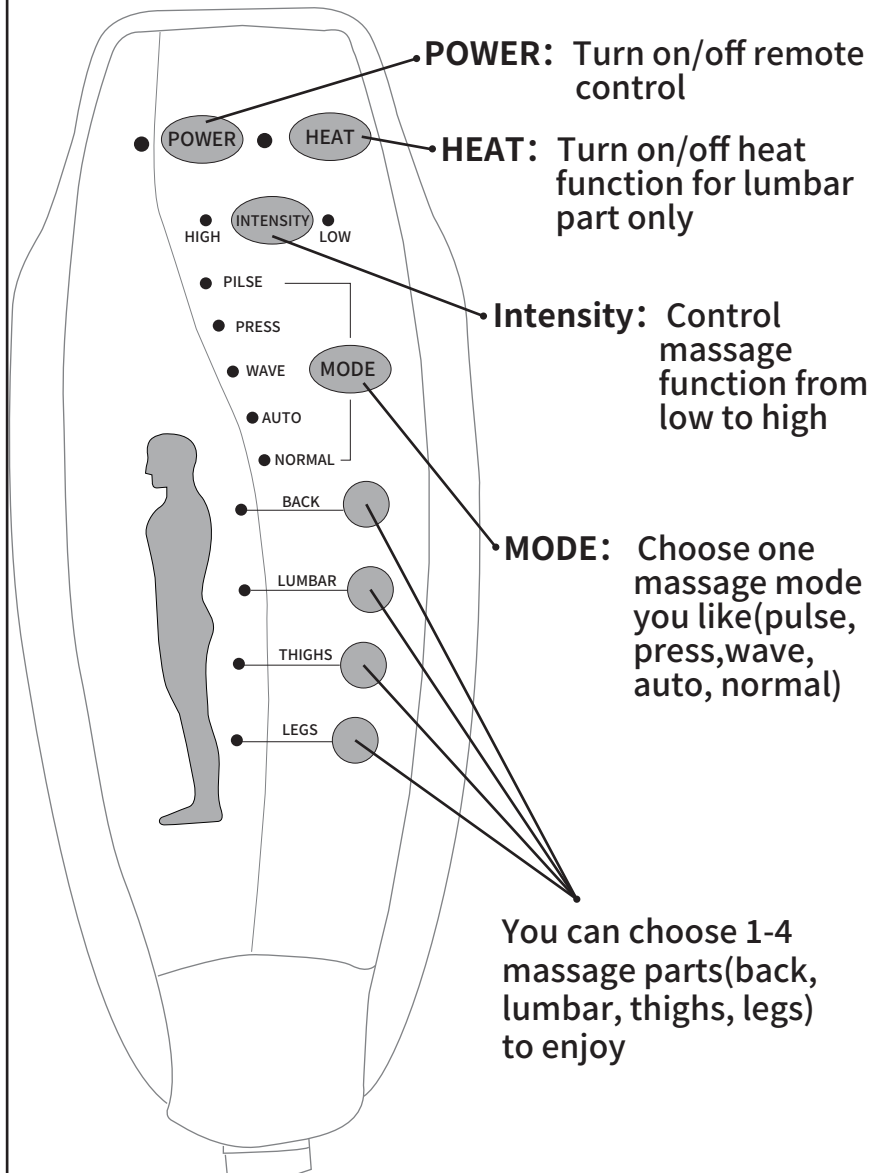

How to use control panel that outside of right armrest?

Control panel is for chair lift and reclining function, also has dual USB outlets (5V2A+Type C) that keep your devices charging, such as nearly all smartphone (like iPhone, Samsung..), ipad, headphones, Kindle...

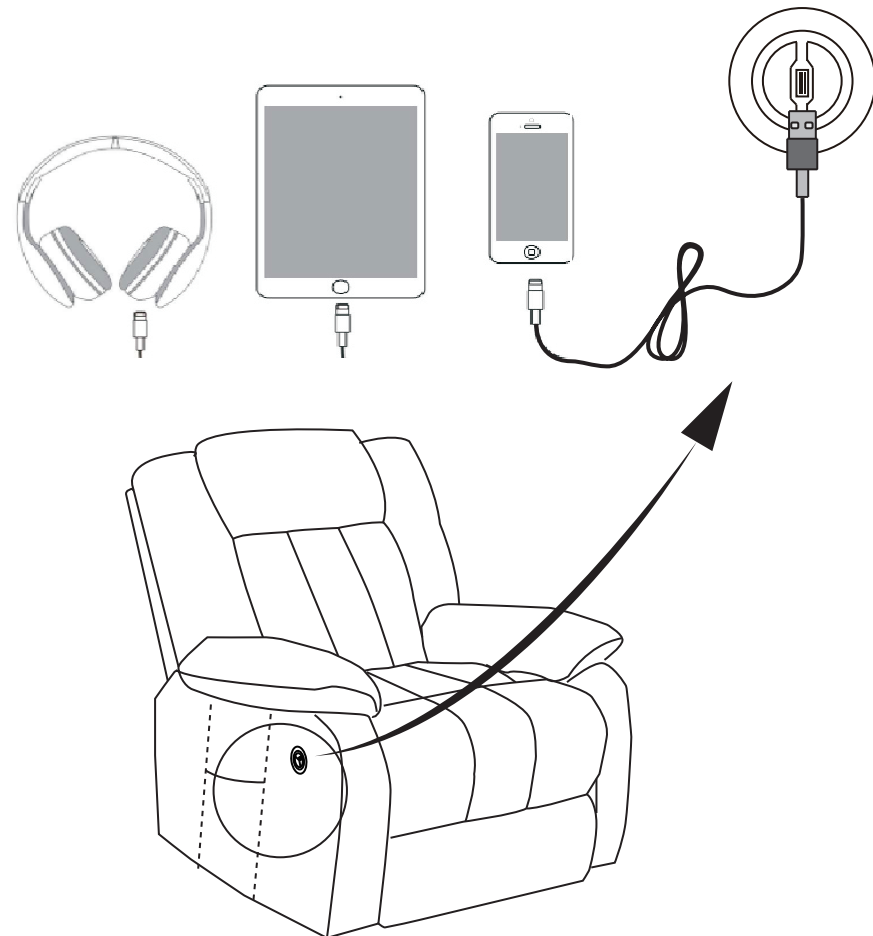

FAQ

1.Q: Missing parts when received.

A: Please check if you already received two boxes we shipped to you. Sometimes the two boxes will not arrive in same date, hope you can wait for 2-3 more days or contact us for more help.

If you already have two boxes, please kindly send us messages to let us know the name of missing part regarding to the first page of instructions. We will send replacement to you asap.

2.Q: Some parts damaged when arrived.

A: Please send clear photos about damaged part to us as attachment, we will check and offer you best solution soon.

3.Q: The massage function does not work.

A: Please check if all wires connect correctly, the power cord (D) may be defective if indicator does not light on, or if the lights doesn't turn on when you press "POWER" button on the remote, that means the remote is defective.

Please kindly send messages with clear photos to describe the problem, then we will send necessary replacement to you.

4.Q: The chair is stuck on lifting or reclining position, and no response when you press the lifting or reclining button.

A: Please kindly check if the power source (F) and control panel are connected well with lift motor(Wire #5 & #6). Sometimes the power source (F) and control panel may fall off from the motor. If they connect well, then check the lift motor if it has some anomaly, like some noise comes out when you press the lift and recline button. If you can make sure the motor is defective, please contact us for replacement.

5.Q: The Heat function does not work or can't feel.

A: Please check all wires connection the same as question 3 first. If the remote also works well, you will need wait for 5-10 mins after you press the "HEAT" button. The heating function only works at lumbar position and the heat temperature isn't very hot.

TRANSPORT AND INSTALLATION

1. The sofa should be especially protected against rain, moisture and crushing by heavy objects during transportation, in order to avoid quality problems during use.
2. Please make sure that the sofa has the safe access required for its entry before it enters your place of use.
3. Sofas are mainly fixed installation, a few are dismantling sofas. When purchasing a sofa, please give full consideration to the size of the door frame and the movable space of the entrance door. If necessary, ask a professional to disassemble the sofa and reassemble it after entering the house, so that it will not damage the sofa's internal structure, seating sensation and surface effect.

CAVEAT

Please read all instructions before use.

If in any doubt about safety, contact a specialized technician for inspection. When using this product, basic safety precautions must be observed to avoid the risk of injury to persons, including the following.

1. Do not use this product in high humidity environments.
2. Do not store or use this product outdoors or in direct sunlight.
3. Someone must be present to watch over children, disabled people or people with reduced mobility when they are near or using the sofa.
4. After using the sofa, please turn off the on/off function of the backrest/-footrest completely before getting up to avoid accidents.
5. Do not sit on the footrest when using the massage sofa to avoid accidents.
6. Do not try to stand on the armrests or backrests to avoid the massage sofa toppling over, this may cause an accident.
7. Always keep the sofa clean and avoid inserting other objects into the gap of the sofa.
8. Please ensure that there are no other obstacles under the footstool or backrest when lowering it, especially for children.

It is not recommended that children use the appliance alone. The following aspects must be considered.

1. Do not allow children to play freely on the sofa alone without adult supervision to be! Limbs may get caught in the seams of the product and the sofa may tilt and cause the child to fall.
2. Do not leave children unattended near the sofa when it opens and closes to avoid unnecessary injuries.

METHODS OF CARE

1. Avoid placing the sofa in direct sunlight above 30°C. Every 10-15 days, use a vacuum cleaner to remove dust etc. and clean the entire sofa.
2. Remove stains as soon as they are stained and avoid scratching or other damaging treatments, thus permanently maintaining the quality of the fabric surface. The surface of the sofa can be covered with a tight-fitting protective cover. When stained with ink-like stains, wipe with a soft white cloth or absorbent paper.
3. If a solvent is to be used to remove a stain, avoid applying it directly to the stain, but pour it onto a clean cloth first and then try to clean the hidden areas on the back. The stain should be wiped in a circular motion from the outside in until it is completely removed. Immediately after wiping, a low-power hair dryer should be used to dry the clean area from the outside in.
4. Be gentle and careful when wiping stains and spots, do not use excessive force. The massage sofa can be covered with a removable, tight-fitting protective cover.
- 5, If you have covered the sofa with a tight-fitting protective cover, please follow the instructions listed on the cover and clean it with a cleaner that does not contain bleach or oxidizing agents. Otherwise the texture and color of the fabric will change.
6. Vacuum regularly:
Vacuum once a week, paying special attention to removing dust between fabric folds. If there are stains, wipe with a dampened clean cloth to avoid leaving traces, preferably from the edge of the stain.
7. How to clean effectively:
Generally speaking, a soft cotton cloth can be moistened with a 1:10 soap

flake solution or 1:20 advanced shampoo, wrung out and gently wiped the stained area. If the stain is too heavy, repeat the process a few times and the stain will be removed. Don't use too much force or the fabric will fade.

8, How to remove stubborn stains:

If the sofa is stuck with chewing and other gelatinous substances, use an ice pack or ice water to cool it down, and then gently wipe it off with a fine silk cloth.