

ASSEMBLY INSTRUCTIONS



Fine Furniture for every stage of life

VANITY

ASSEMBLY INSTRUCTIONS

ASSEMBLY TIPS:

1. Remove hardware from box and sort by size.
2. Please check to see that all hardware and parts are present prior to start of assembly.
3. Please follow attached instructions in the same sequence as numbered to assure fast & easy assembly.



WARNING!

1. Don't attempt to repair or modify parts that are broken or defective. Please contact the store immediately.
2. This product is for home use only and not intended for commercial establishments.



ASSEMBLY TIME 99 MINUTES

PARTS IDENTIFICATION

B2: VANITY BASE & GLASS

A

TOP PANEL

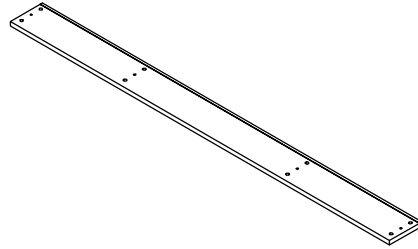

1PC

B

LEFT CABINET LEFT PANEL

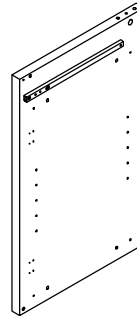

1PC

C

LEFT CABINET RIGHT PANEL

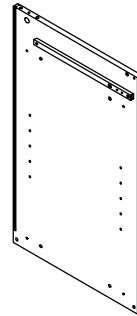

1PC

D

RIGHT CABINET LEFT PANEL

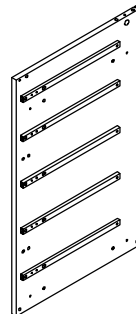

1PC

ASSEMBLY INSTRUCTIONS

PARTS IDENTIFICATION

E RIGHT CABINET RIGHT PANEL

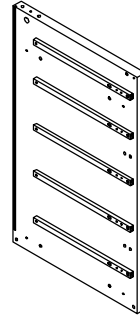

1PC

F BACK PANEL

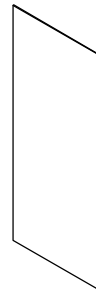

2PCS

G SUPPORT PANEL

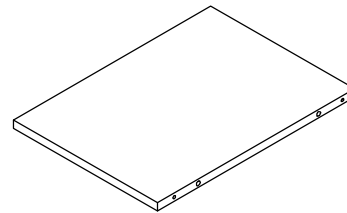

2PCS

H BOTTOM PANEL

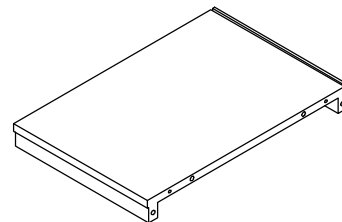

2PCS

I MIDDLE BOTTOM PANEL

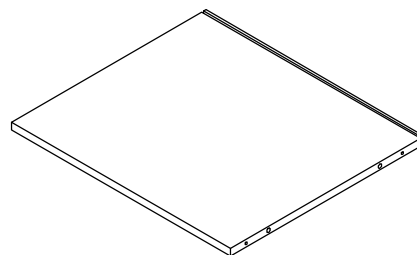

1PC

ASSEMBLY INSTRUCTIONS

PARTS IDENTIFICATION

J

MIDDLE BACK PANEL

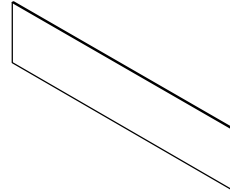

1PC

K

LONG TOP SUPPORT PANEL

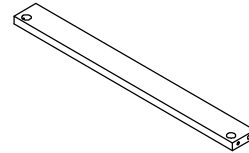

1PC

L

SHORT TOP SUPPORT PANEL

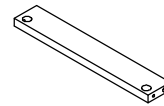

2PCS

M

DOOR PANEL

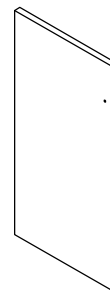

1PC

N

LARGE DRAWER FRONT PANEL

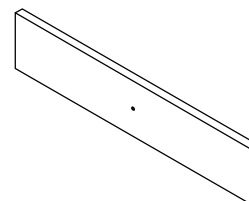

1PC

ASSEMBLY INSTRUCTIONS

PARTS IDENTIFICATION

O

LARGE AND SMALL DRAWER
LEFT PANEL

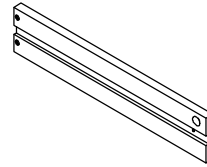

3PCS

P

LARGE AND SMALL DRAWER
RIGHT PANEL

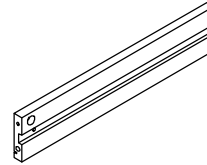

3PCS

Q

LARGE DRAWER BACK PANEL

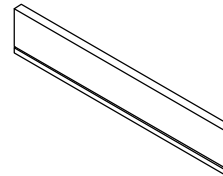

1PC

R

LARGE DRAWER BOTTOM PANEL

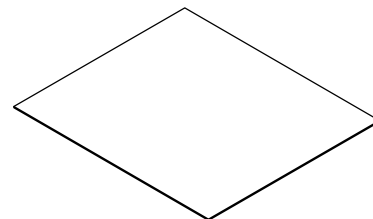

1PC

S

SMALL DRAWER FRONT PANEL

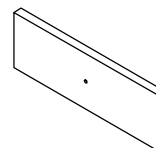

2PCS

ASSEMBLY INSTRUCTIONS

PARTS IDENTIFICATION

T

SMALL DRAWER BACK PANEL

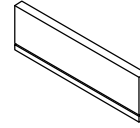

2PCS

U

MEDIUM AND SMALL DRAWER
BOTTOM PANEL

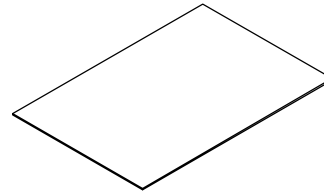

6PCS

V

MEDIUM DRAWER FRONT PANEL

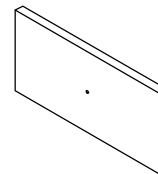

4PCS

A1

MEDIUM DRAWER LEFT PANEL

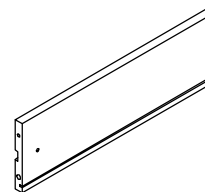

4PCS

A2

MEDIUM DRAWER RIGHT PANEL

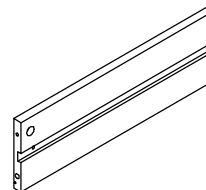

4PCS

ASSEMBLY INSTRUCTIONS

PARTS IDENTIFICATION

A3

MEDIUM DRAWER BACK PANEL

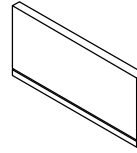

4PCS

A4

SHELF PANEL

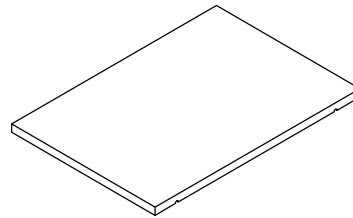

1PC

A5

RIGHT CABINET SUPPORT PANEL

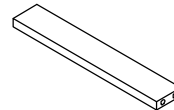

2PCS

A6

HINGE

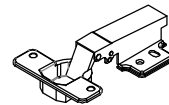

2PCS

A7

GLASS

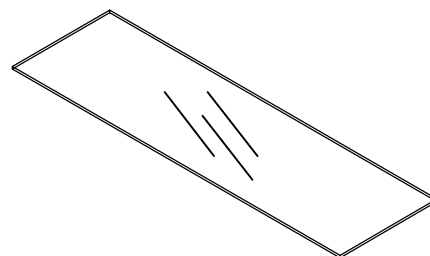

1PC

ASSEMBLY INSTRUCTIONS

PARTS IDENTIFICATION

A8 HANDLE BASE



8PCS

A9 HANDLE



8PCS

B1: VANITY TOP

A10 CROSSBAR

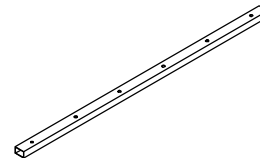

2PCS

A11 MAKE-UP MIRROR

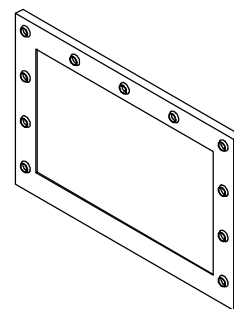

1PC

B3: 11PCS LIGHT BULB

A12 LIGHT BULB



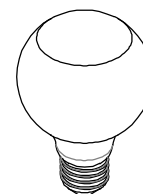













TYPE G / E26 CLEAR LIGHT BULB / 4 WATT.



11PCS

ASSEMBLY INSTRUCTIONS

HARDWARE IDENTIFICATION

1	LARGE CAM BOLT (38MM)		26PCS	11	SHELF BOLT		4PCS
2	SMALL CAM BOLT		18PCS	12	CAP (20 x 30mm)		4PCS
3	LARGE CAM-LOCK (Ø15MM)		30PCS	13	SUCTION CUP		8PCS
4	SMALL CAM-LOCK (Ø12mm)		14PCS	14	LONG BOLT (1/4" x 35mm SR)		12PCS
5	WOOD DOWEL (8 x 30mm)		50PCS	15	GLUE		2PCS
6	WOOD DOWEL (6 x 25mm)		14PCS	16	ALLEN WRENCH (4mm)		1PC
7	LONG SCREW (8 x 25mm)		28PCS				
8	SHORT SCREW (3.5 x 12mm)		12PCS				
9	SMALL BOLT (5/32" x10mm)		14PCS				
10	LONG BOLT (5/32" x22mm)		8PCS				

Hardware pack is located in 931143B2

ASSEMBLY INSTRUCTIONS

STEP 1

Do not tighten until each step is completed or instructed.

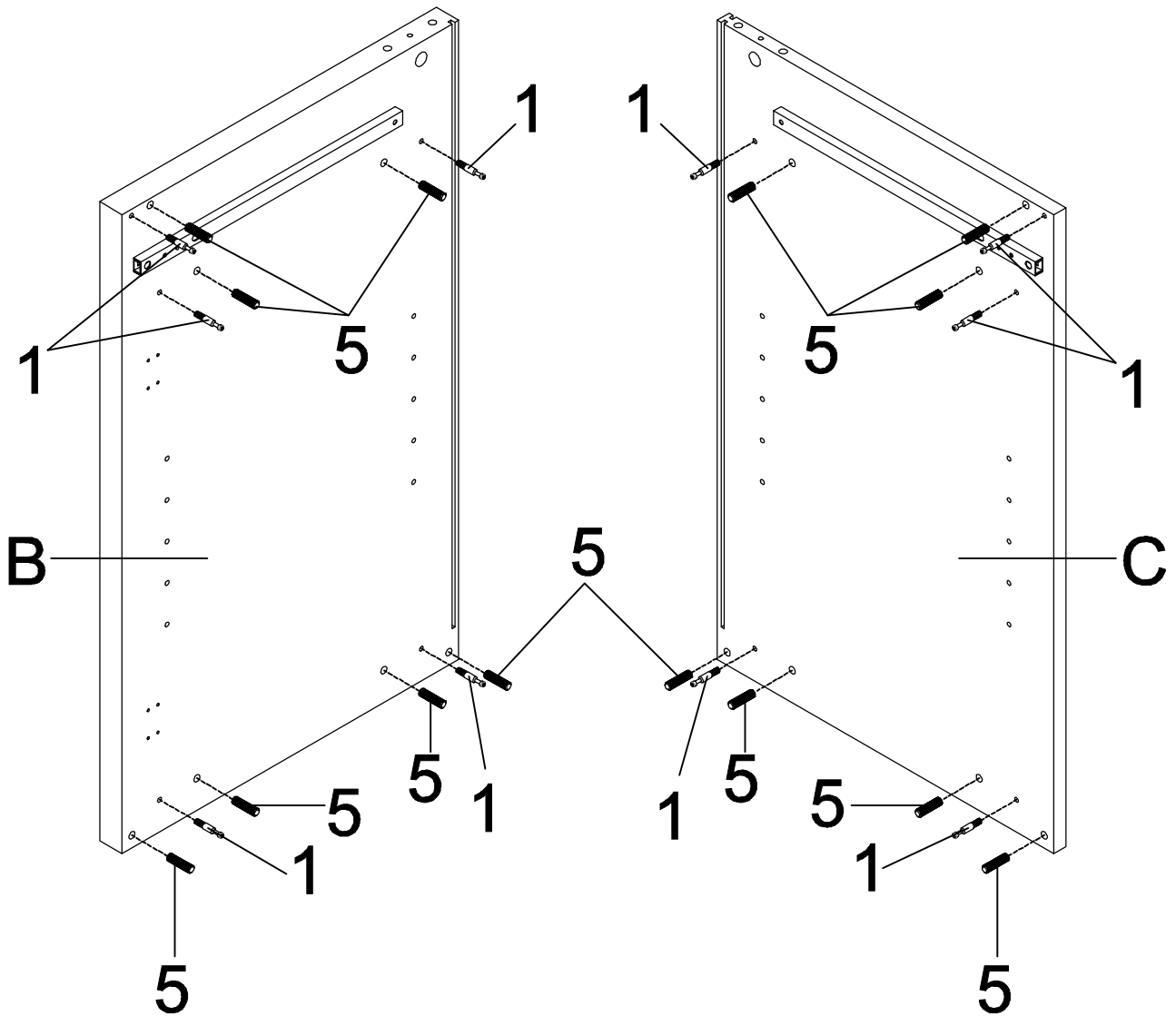
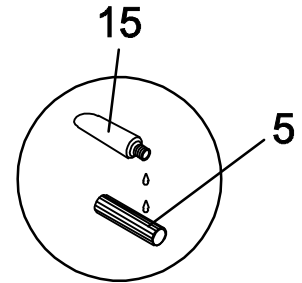

ASSEMBLY INSTRUCTIONS

STEP 2

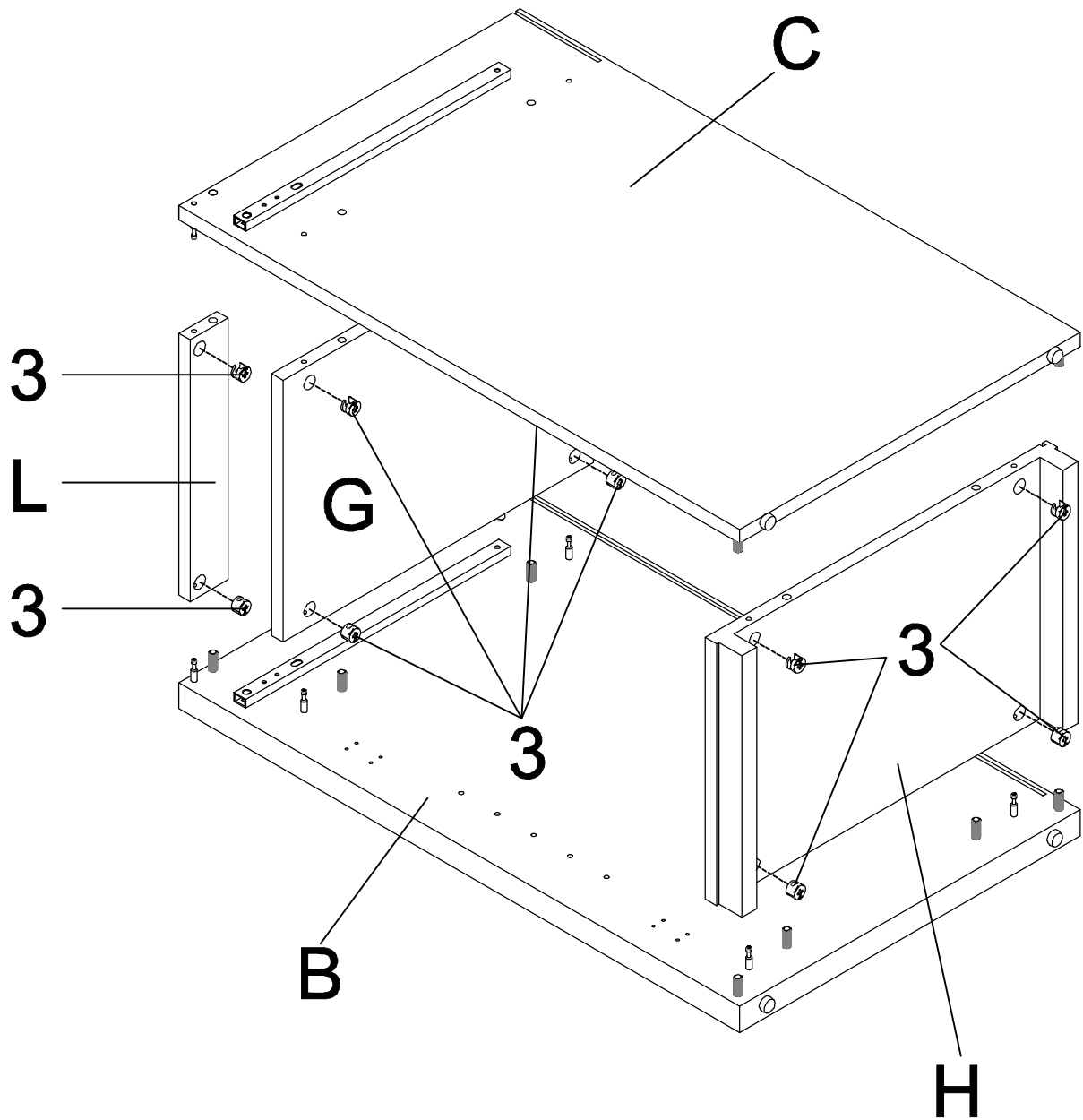

ASSEMBLY INSTRUCTIONS

STEP 3

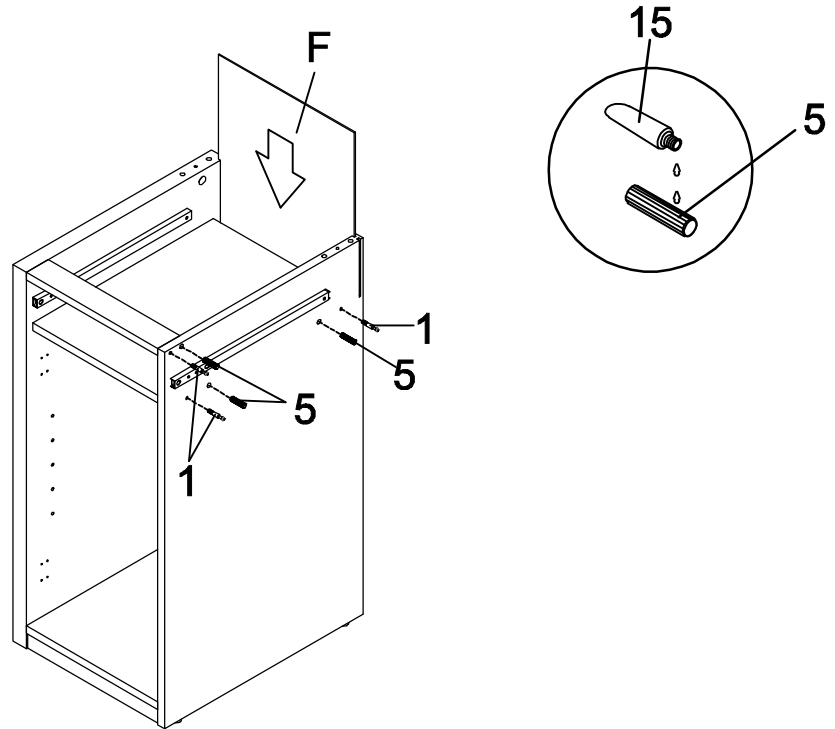

STEP 4

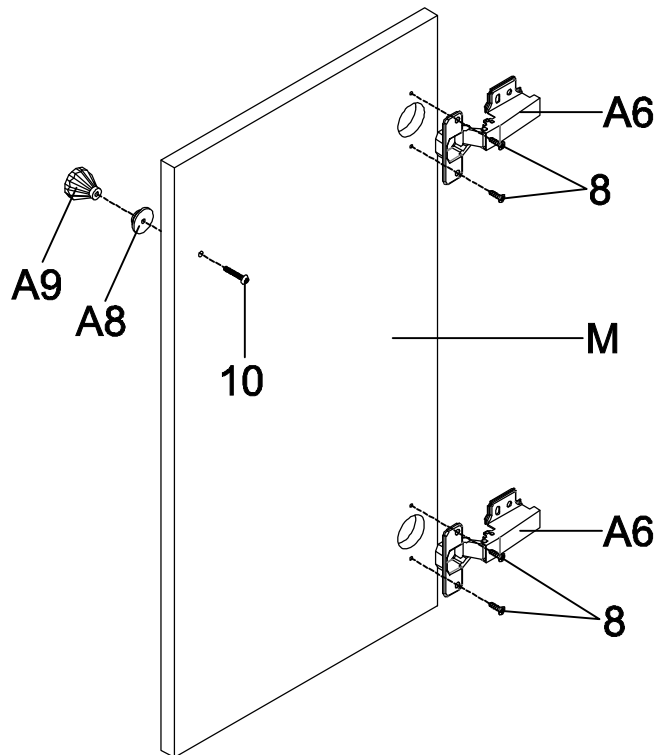

ASSEMBLY INSTRUCTIONS

STEP 5

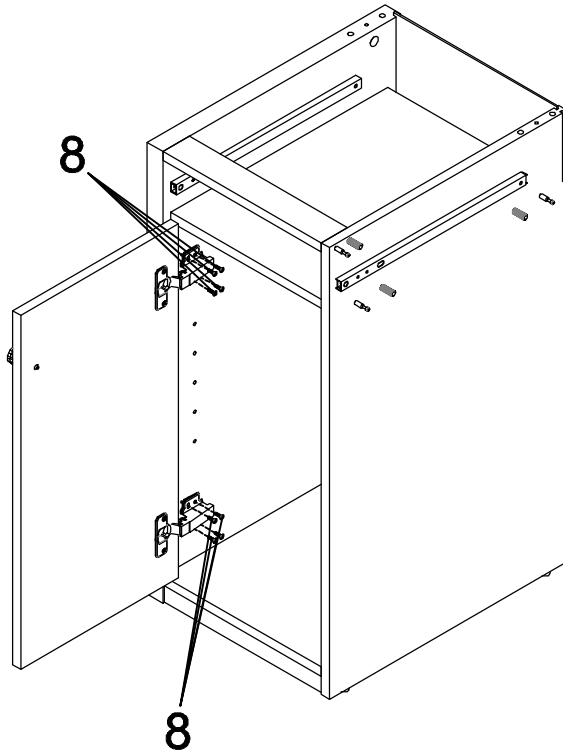

STEP 6

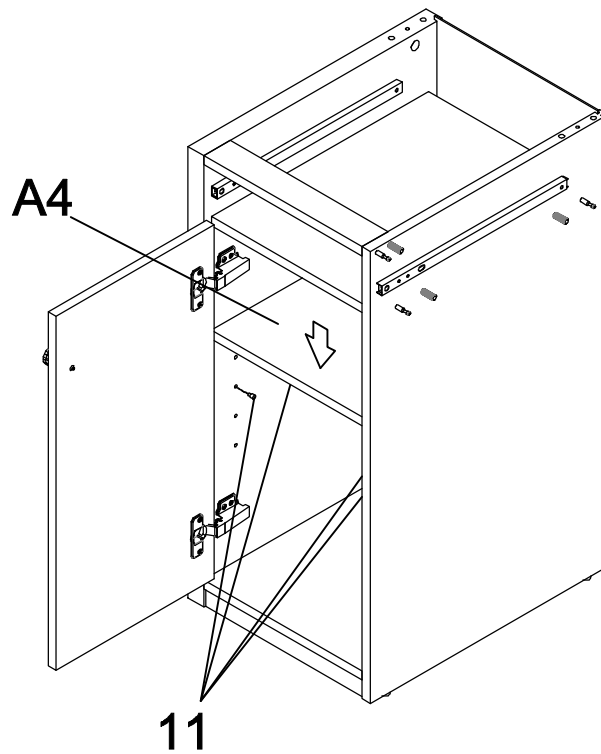

ASSEMBLY INSTRUCTIONS

STEP 7

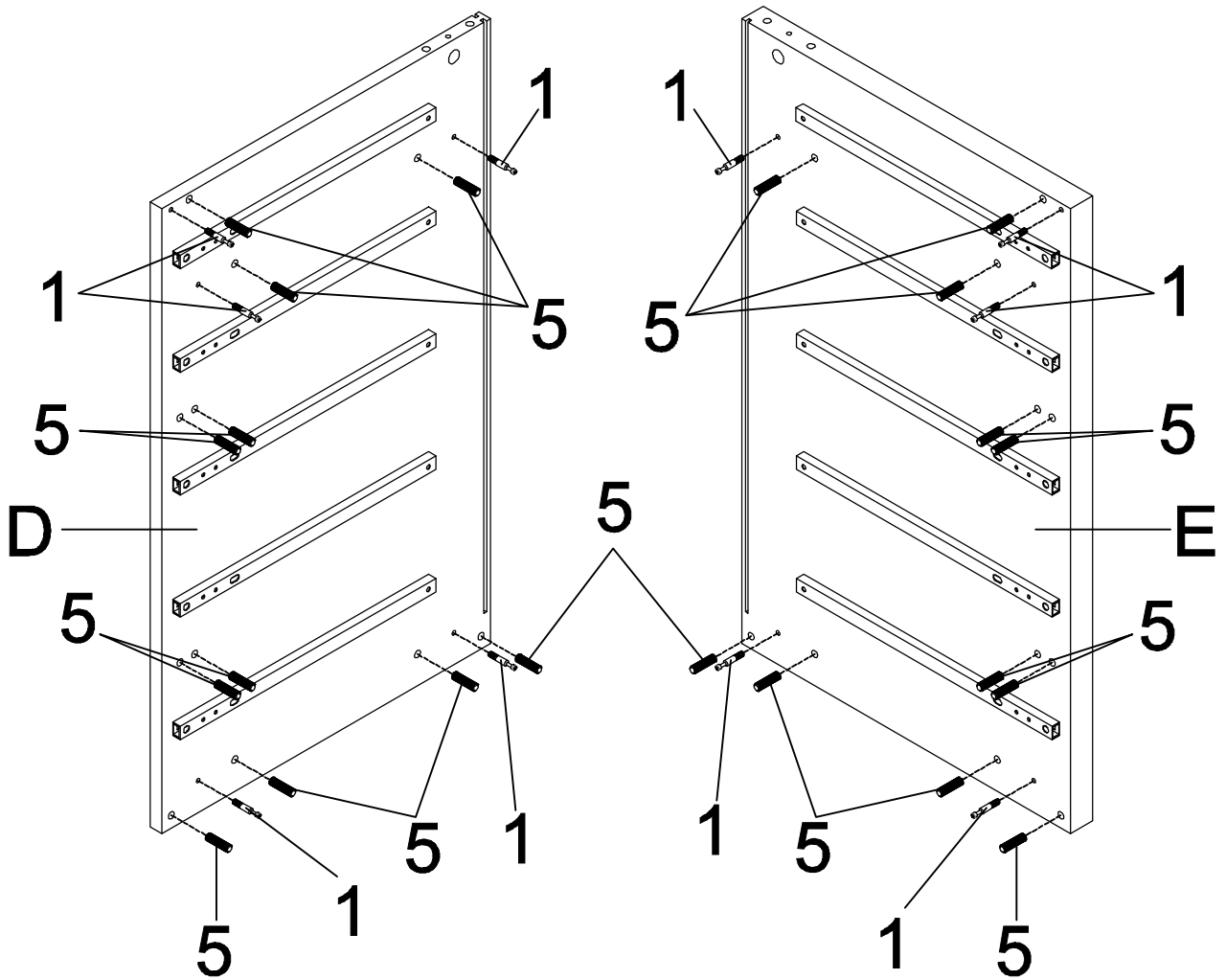
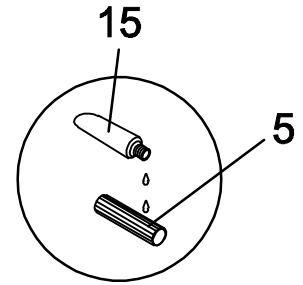

ASSEMBLY INSTRUCTIONS

STEP 8

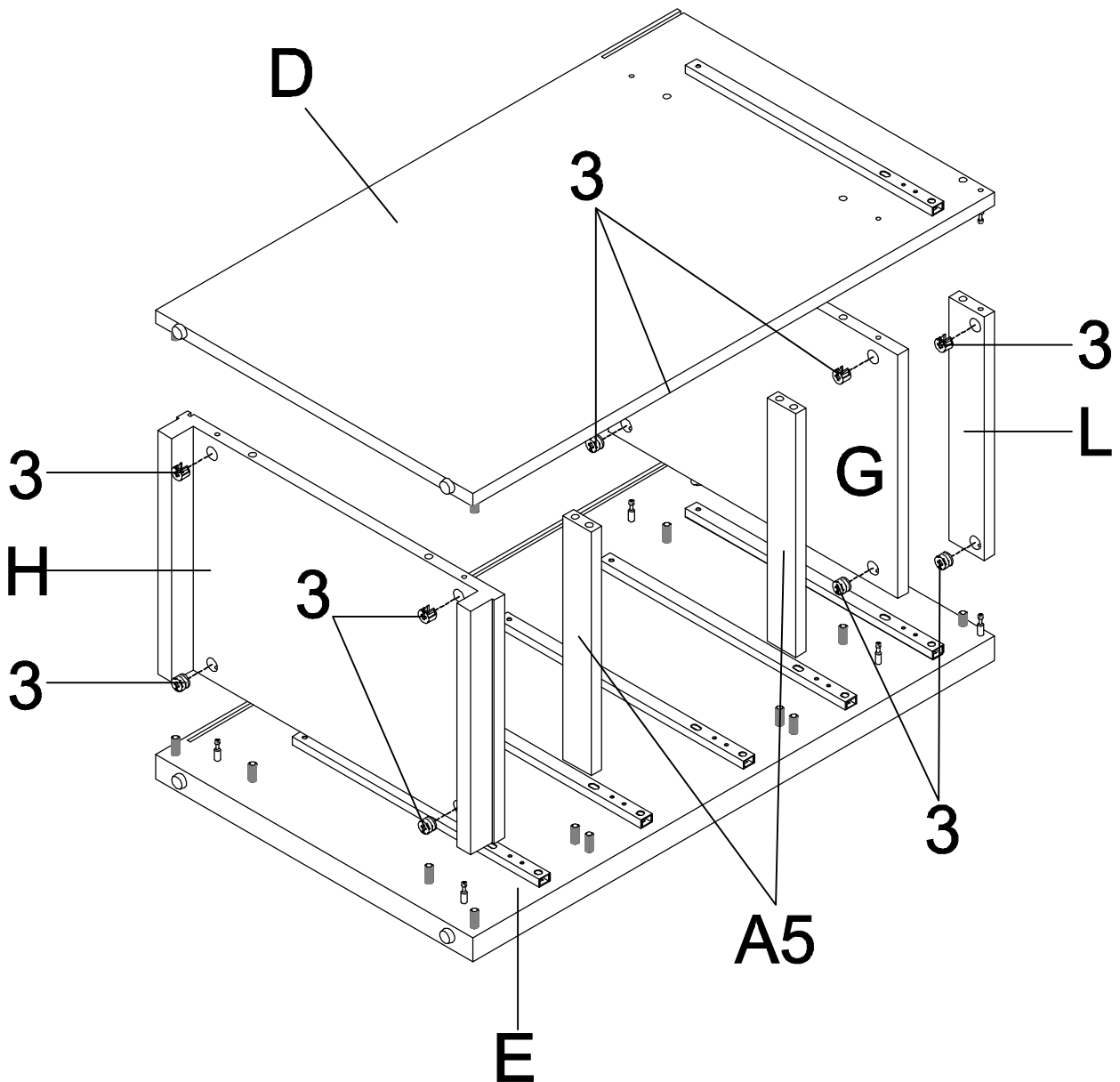

ASSEMBLY INSTRUCTIONS

STEP 9

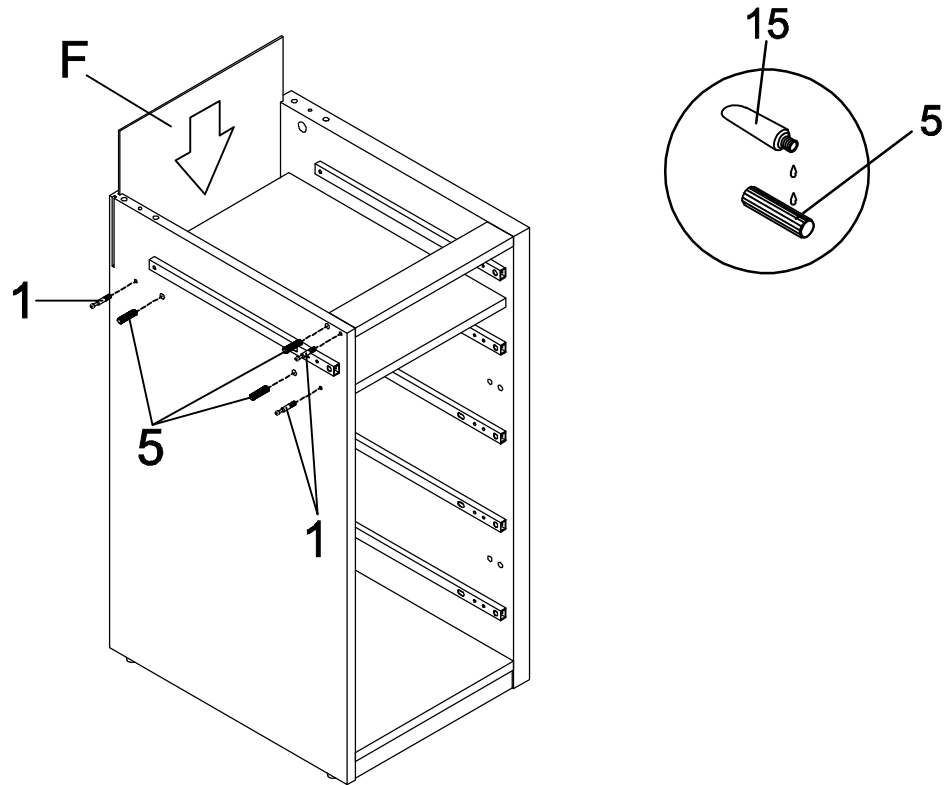

STEP 10

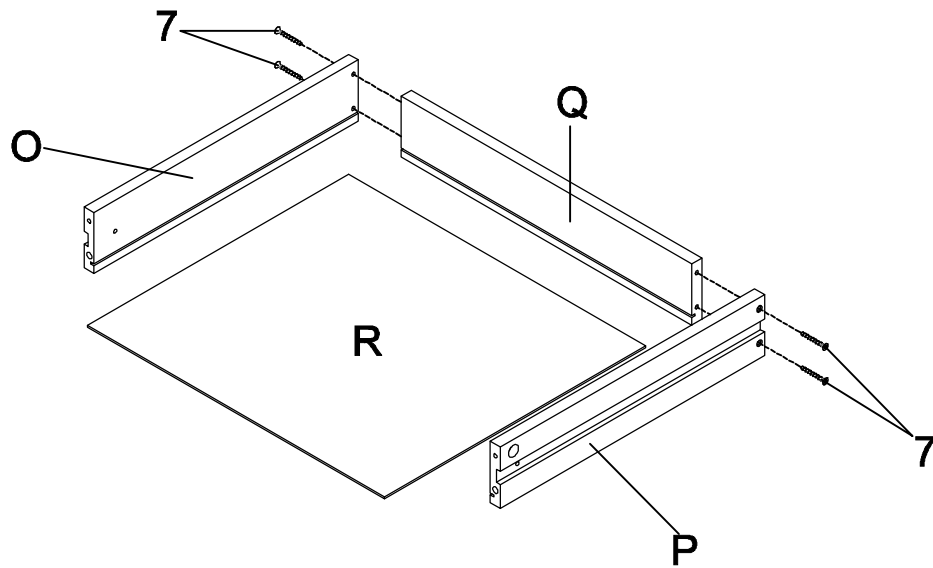

ASSEMBLY INSTRUCTIONS

STEP 11

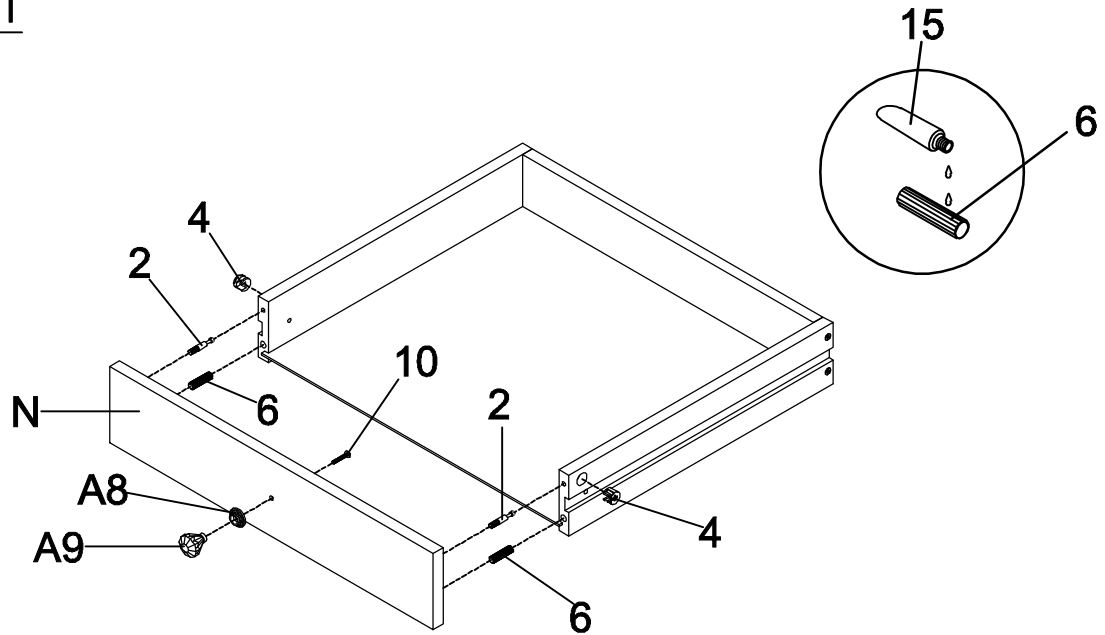

STEP 12

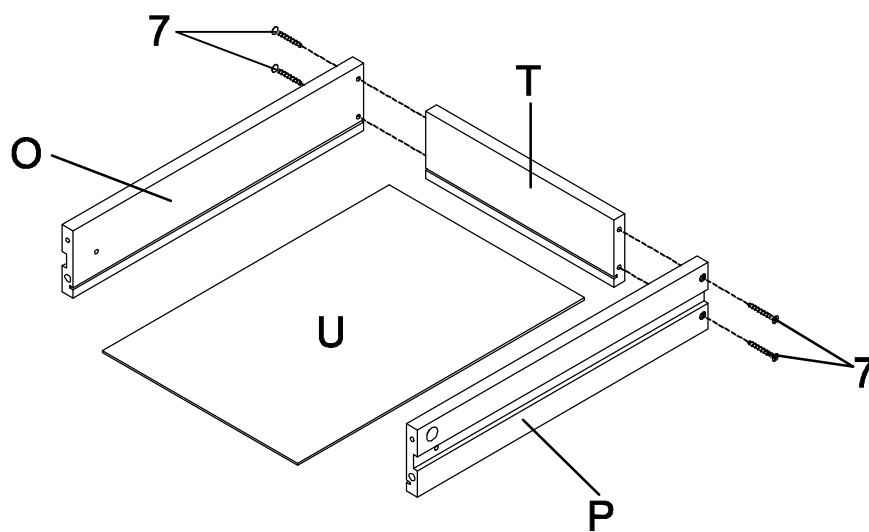

ASSEMBLY INSTRUCTIONS

STEP 13

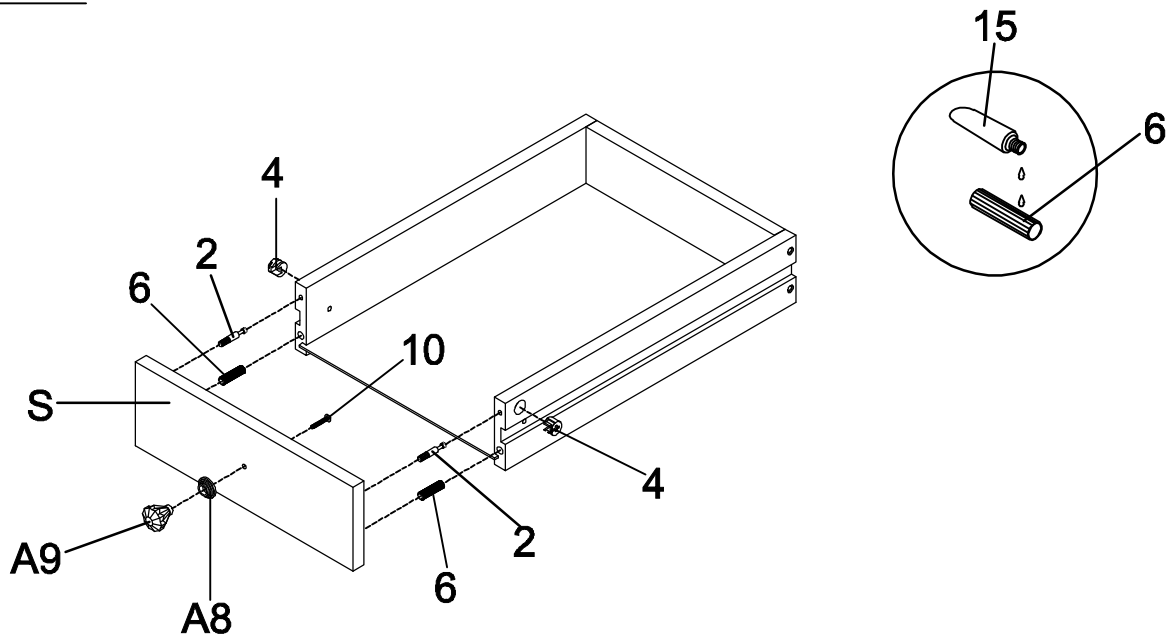

STEP 14

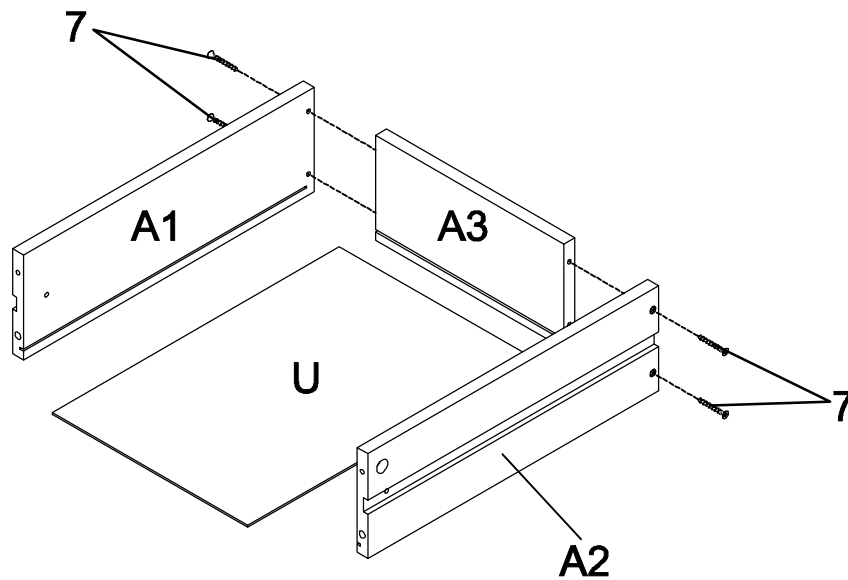

STEP 15

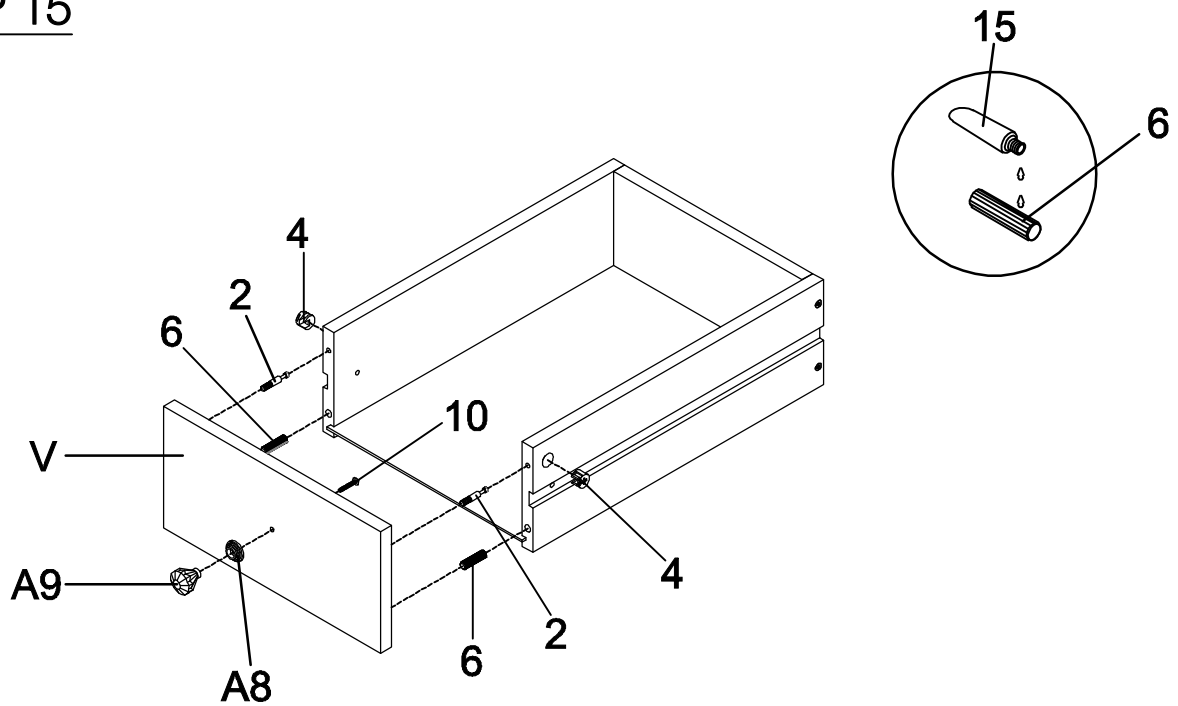

STEP 16

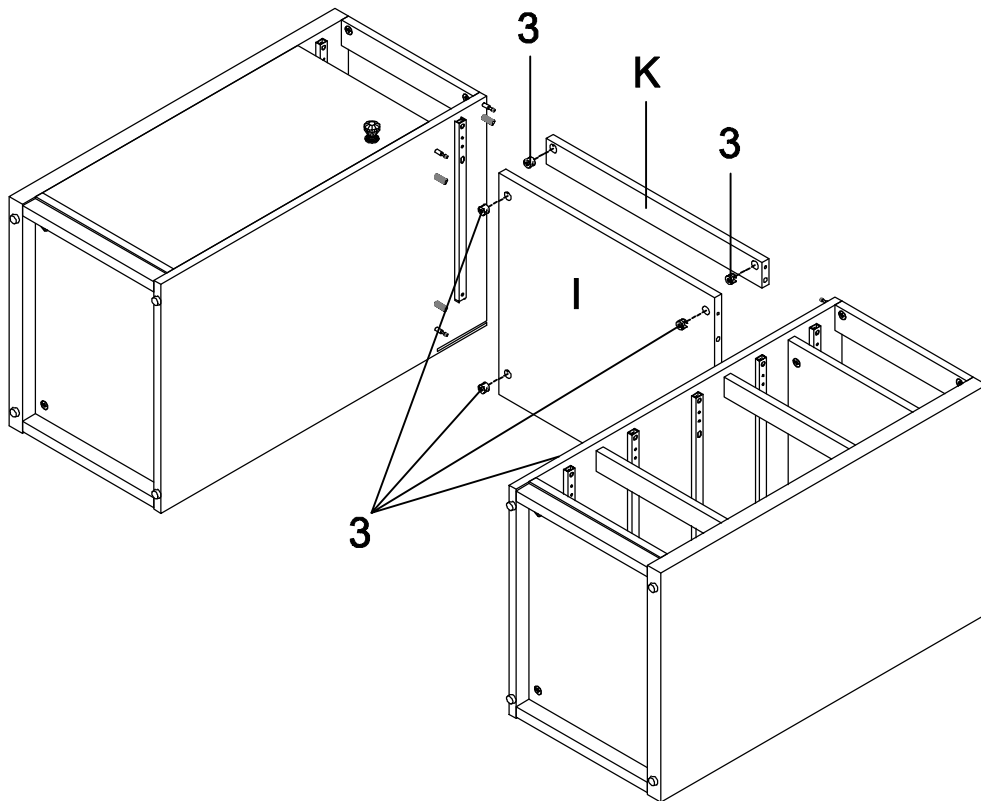

ASSEMBLY INSTRUCTIONS

STEP 17

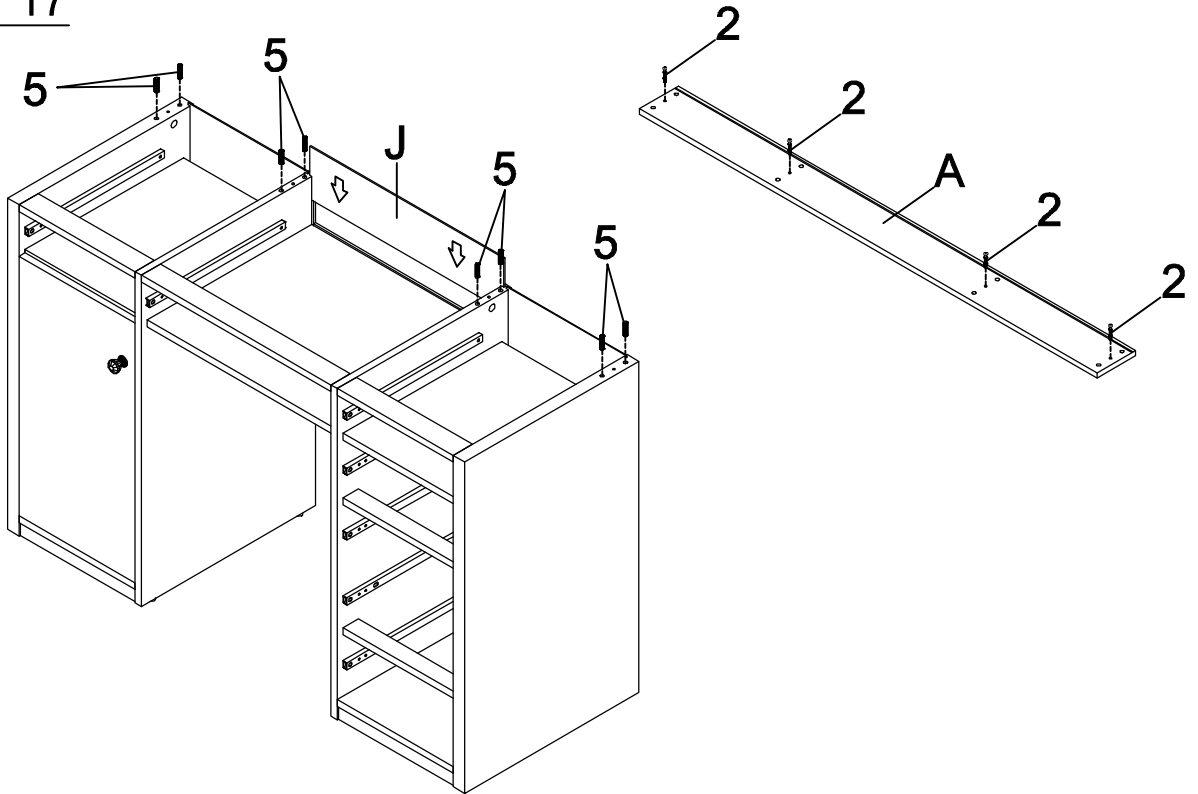

STEP 18

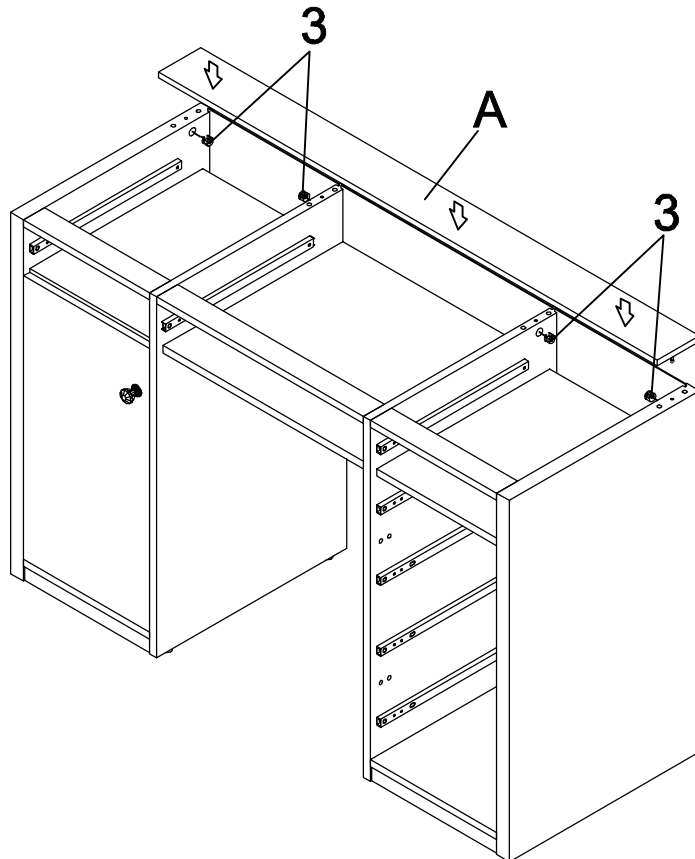

ASSEMBLY INSTRUCTIONS

STEP 19

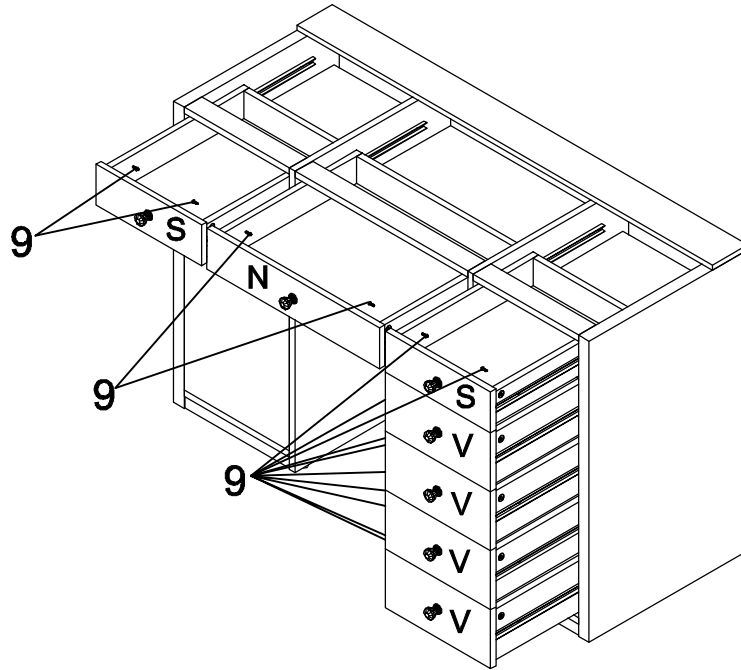

STEP 20

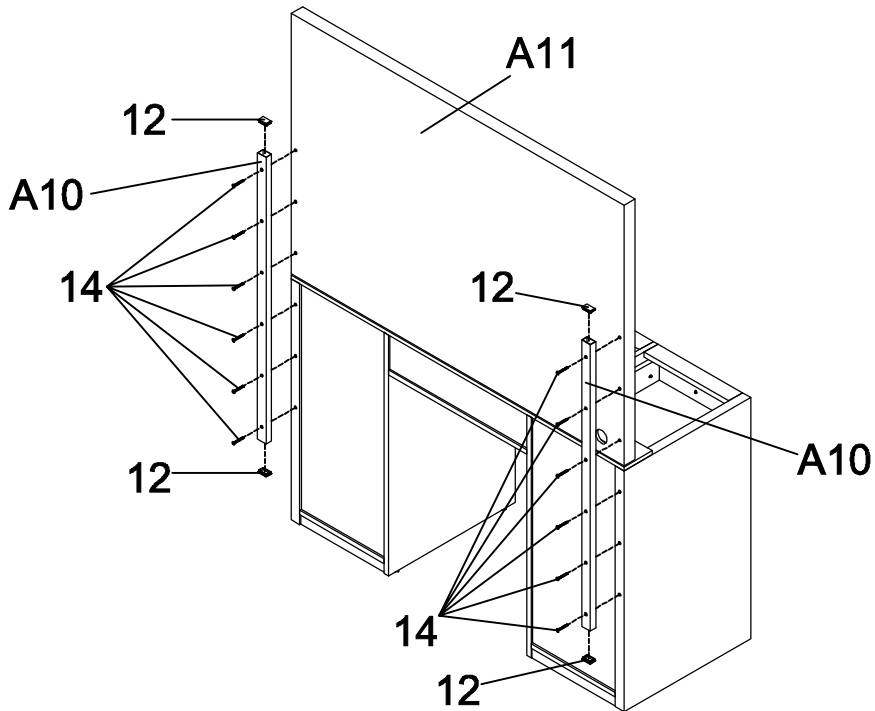

STEP 21

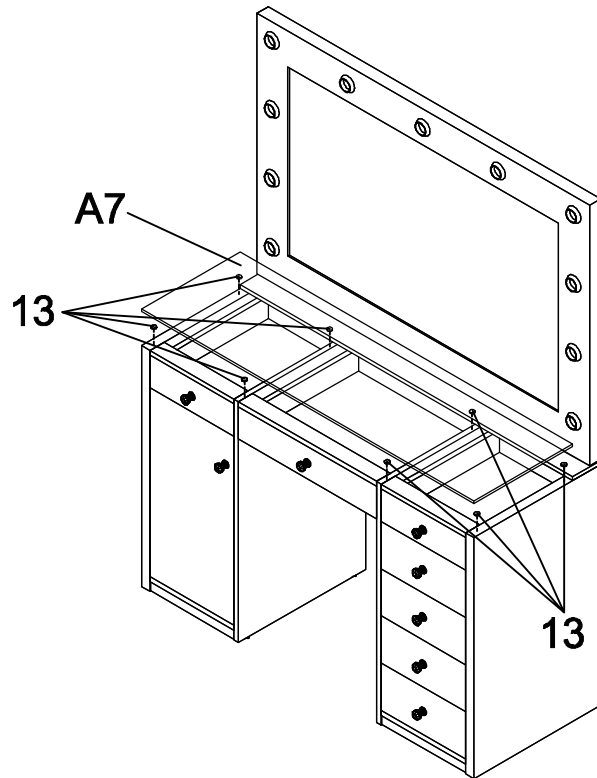

STEP 22
COMPLETE

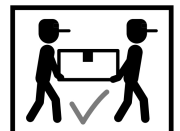
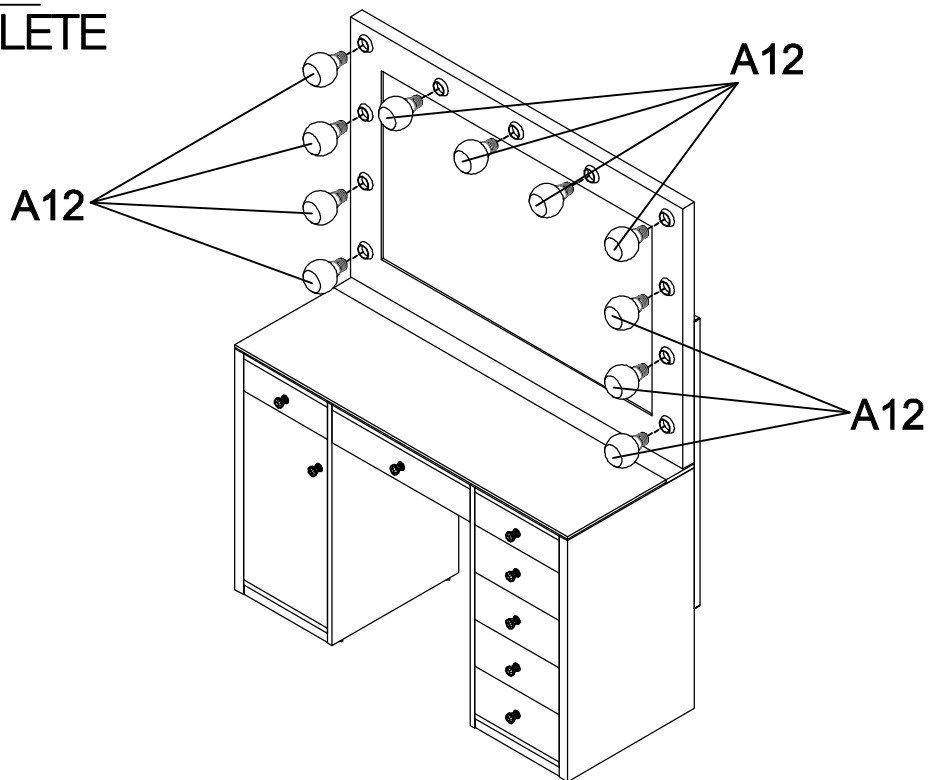

ASSEMBLY INSTRUCTIONS

Product Size : 1181 X 470 X 1562 H (MM)
 Product Size : 46.5" X 18.5" X 61.5"

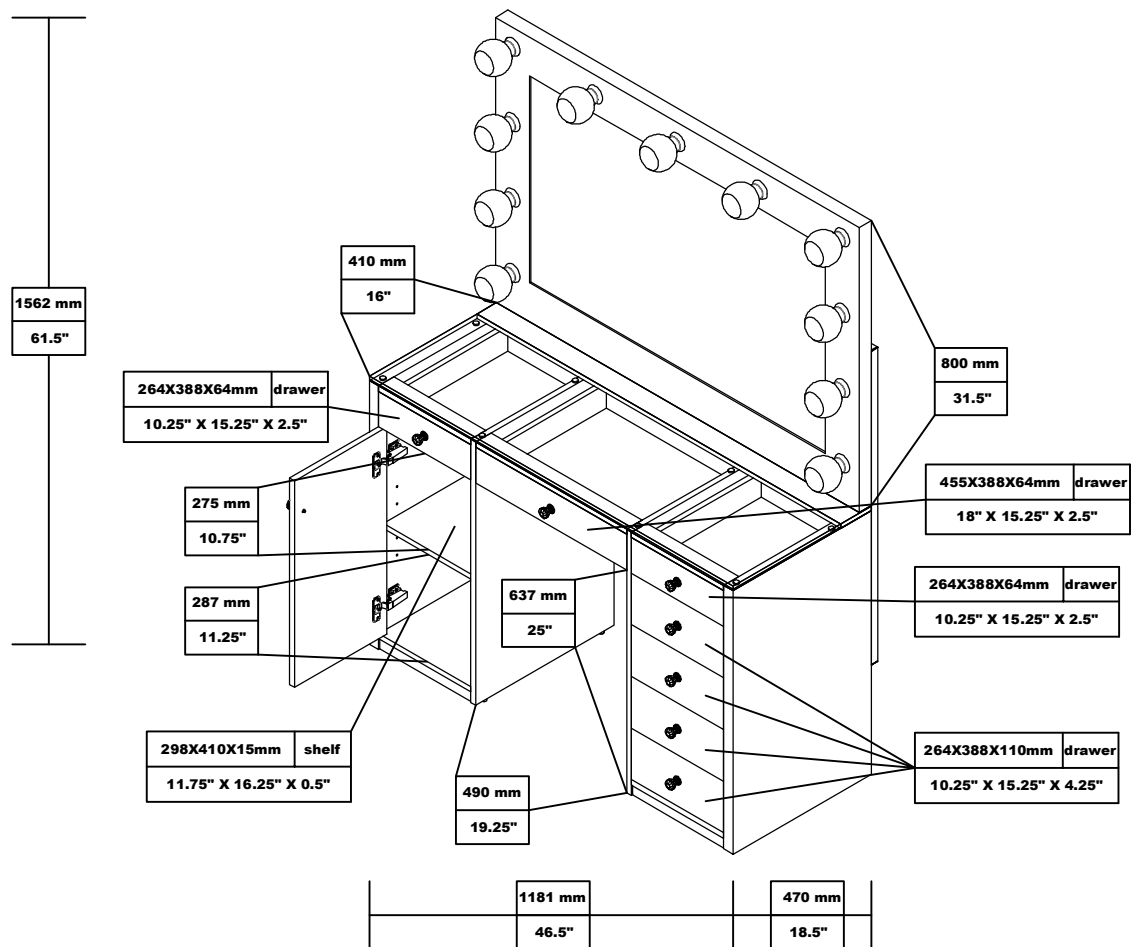

Note : Dimension tolerance $\pm 5\%$