





ASSEMBLY INSTRUCTION

ITEM : 65032

Description : Spindleback Windsor Chair

No	Part List	Qty
A	Chair Back	1
B	Legs Frame	2
C	Stretchers	1

No	Hardware List	Qty
D	JCBC Bolt M6 x 50 mm 	2
E	Barrel Nut 	2
F	JCBC Screw M7 x 35mm 	6
G	Allen Key 	1
H	Wood Button 	2

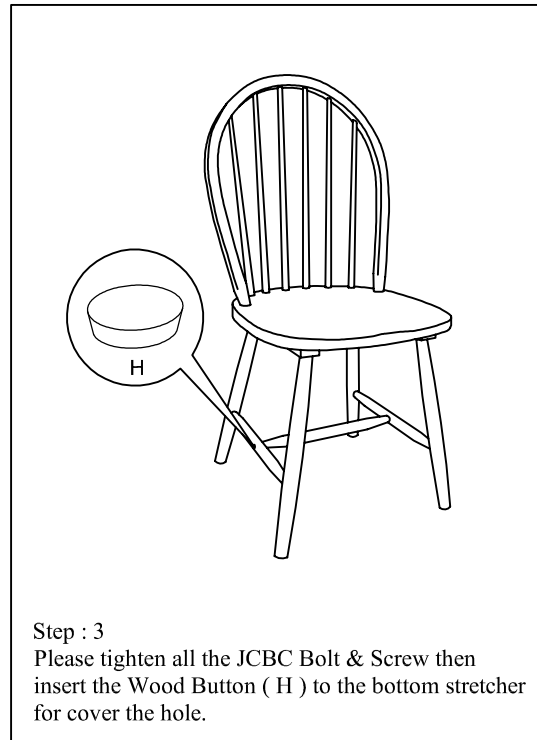
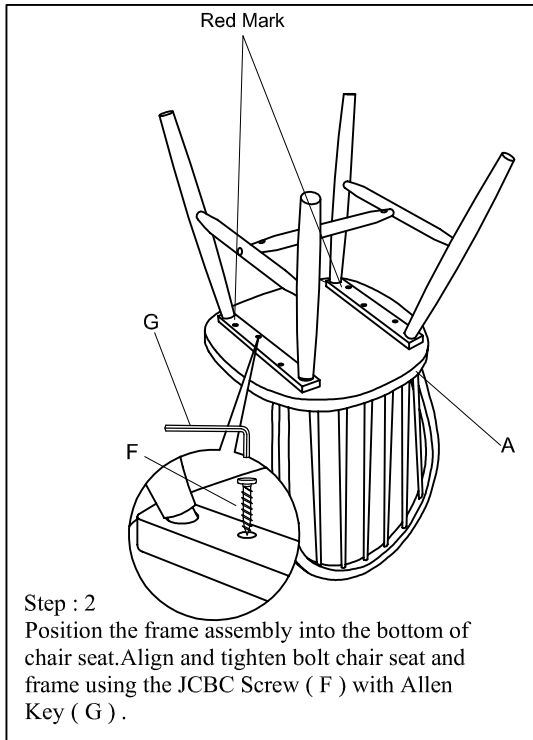
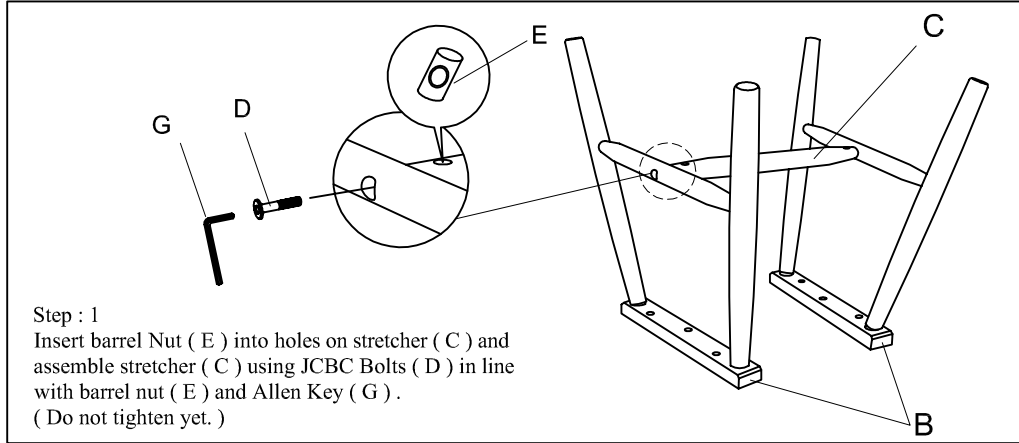

Thank you for purchasing our product!

Please assemble the products with the guidance of this manual instruction.

Contact our friendly customer service department with any comments or in case there is any missing or damaged parts or hardware. Replacements for missing or damaged parts or hardware are normally shipped within 2 to 3 days.

Email: replacementparts@buylateral.com

Within 30-days from delivery date

PRODUCTS PURCHASED THROUGH OUR AUTHORIZED VENDORS ONLY ARE ELIGIBLE FOR REPLACEMENT PARTS.

We appreciate your business!

THIS PRODUCTS IS FOR INDOOR AND HOUSEHOLD USE ONLY- NOT FOR COMMERCIAL USE.



- After a few days of initial assembly and chairs have acclimated to new environment retighten all hardware.
- For a permanent attachment, suggest that glue be used on stretcher ends.

Important Notes