

desk

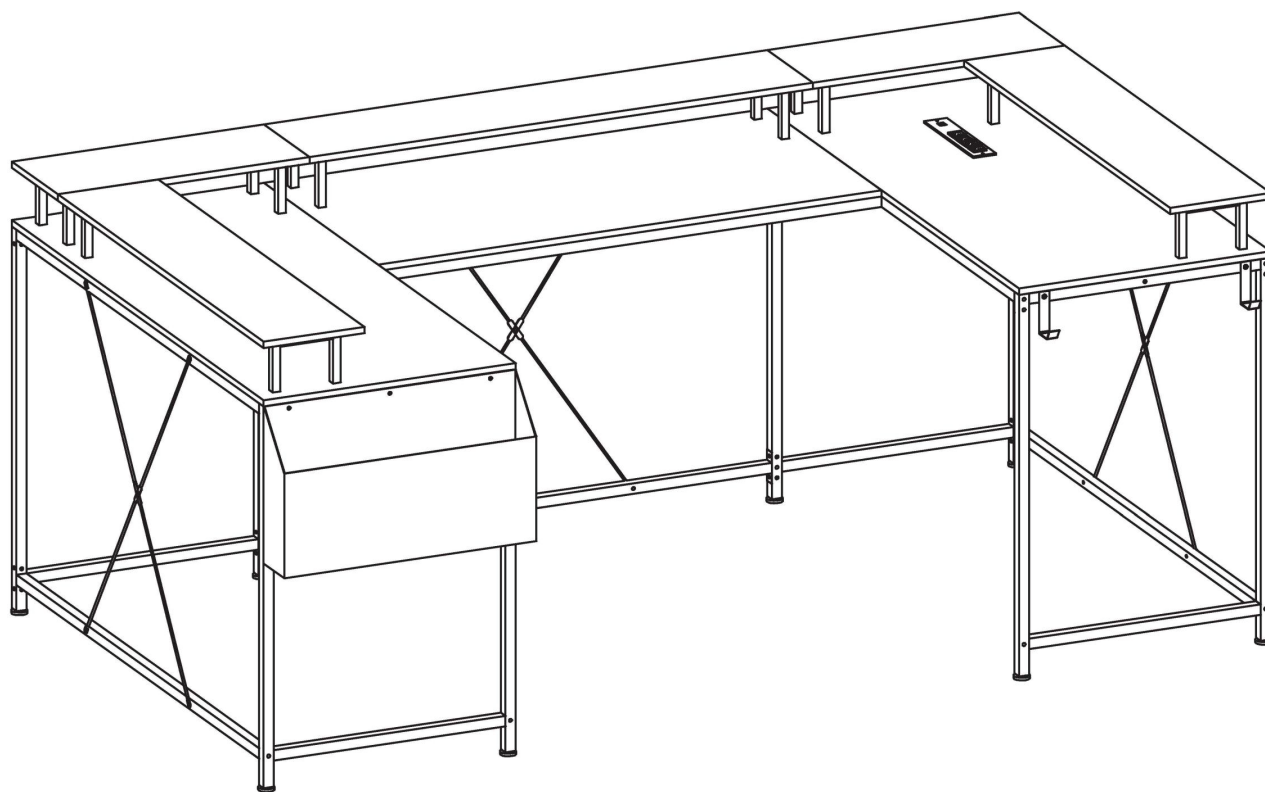

EN**WARNING****The product must be assembled by adult before use.**

Serious or fatal injury may occur from unexpected assembly or use.

1. During the assembly process, keep all parts away from babies or children.
2. Always securely fix this product to the wall. Make sure the wall area to be drilled is free from hidden electrical wires, water and gas pipes.
3. Use of tip-over restraints may only reduce, but not eliminate the risk of tip-over.
4. Unless specially designed to accommodate, do not set heavy objects on top of this product.
5. Place the heaviest items on the lowest layer.
6. Never allow children to climb or bump drawers, doors or shelves.

FR

Merci d'avoir acheté notre produit. S'il vous plaît contactez-nous si vous avez des difficultés avec assemblage ou besoin de pièces de remplacement.

**ATTENTION****Le produit doit être assemblé par un adulte avant utilisation.**

Des blessures graves ou mortelles peuvent survenir à cause de l'assemblage ou l'utilisation inattendue.

1. Pendant le processus de montage, gardez toutes les pièces loin des bébés et des enfants.
2. Fixer toujours sécuritaire ce produit au mur. Assurez-vous que la zone du mur à percer est libre de fils électriques cachés, de conduites d'eau et de gaz.
3. L'utilisation de dispositifs de retenue pour le renversement ne peut que réduire, mais pas éliminer le risque de renversement.
4. Sauf si spécialement conçu pour accueillir, ne posez pas d'objets lourds au sommet de ce produit.
5. Placez les articles les plus lourds sur la tablette la plus basse.
6. Ne laissez jamais les enfants grimper ou cogner sur les tiroirs, les portes ou les étagères.

IT

Grazie per aver acquistato il nostro prodotto. In caso dei problemi durante l'assemblaggio o la sostituzione, si prega di contattarci senza esitazione.

**AVVERTIMENTO****Il prodotto deve essere assemblato da un adulto prima dell'uso.**

L'inaspettato montaggio potrebbe provocare i lesioni gravi o mortali.

1. Durante l'assemblaggio, metti tutti i parti fuori dalla portata dei bambini.
2. Sempre fissare saldamente questo prodotto alla parete. Assicurarsi che l'area della parete sia libera dai cavi elettrici nascosti, i tubi dell'acqua e del gas.
3. La restrizione punta-over può ridurre il rischio di punta-over ma non può eliminarlo.
4. A meno che con l'appositamente progettato, Non deporre gli oggetti pesanti sul piano superiore
5. Posiziona le robe più pesante al piano inferiore.
6. Non permettere i bambini di scalare o battere i cassetti, le porte o gli scaffali.

DE**WARNUNG****Der Produkt muss vor Gebrauch von einem Erwachsenen zusammengebaut werden.**

Bei unerwarteter Montage oder Verwendung können schwere oder tödliche Verletzung auftreten.

1. Legen Sie in den Montageprozess alle Teile weg von Babys oder Kindern.
2. Befestigen Sie dieses Produkt immer sicher an der Wand. Um sicherzustellen, dass der zu bohrende Wandbereich entfernt von verdeckten Stromkabeln, Wasser- und Gasleitungen ist.
3. Die Verwendung von Kippsicherungen kann die Gefahr eines Kippens nur verringern, jedoch nicht beseitigen.
4. Setzen Sie bitte keine schweren Gegenstände auf dieses Produkt, es sei denn, dass das Produkt speziell für die Unterbringung konzipiert wird.
5. Legen Sie bitte die schwersten Gegenstände auf das unterste Regal.
6. Erlauben Sie nie Kindern, auf Schubladen, Türen oder Regale zu klettern oder zu knallen.

ES

Gracias por adquirir nuestro producto. Por favor, póngase en contacto con nosotros si tiene dificultades con montaje o necesidad de repuestos.



ADVERTENCIA

El producto debe ser ensamblado por un adulto antes de su uso.

Se pueden producir lesiones graves o fatales debido al montaje o uso inesperado.

1. Durante el proceso de montaje, mantenga todas las piezas alejadas de bebés o niños.
2. Fije siempre este producto de forma segura a la pared. Asegúrese de que el área de la pared a perforar esté libre de cables eléctricos ocultos, tuberías de agua y gas.
3. El uso de restricciones de vuelco solo puede reducir, pero no elimina el riesgo de que se vuelque.
4. A menos que esté especialmente diseñado para acomodarse, no coloque objetos pesados encima de este producto.
5. Coloque los artículos más pesados en el estante más bajo.
6. Nunca permita que los niños se suban o golpeen los cajones, puertas o estantes.

JP

弊社製品をお買い上げいただき、誠にありがとうございます。ご不明な点がございましたら、お問い合わせください。組み立てに問題が発生した場合、または部品を交換する必要がある場合は、カスタマーサービスチームに連絡して申し付けください。



ご注意

製品は、使用する前に大人が組み立てる必要があります。

誤って組み立てたり使用したりすると、重傷または致命傷を負う可能性があります。

1. 組み立て中は、すべての部品を乳幼児や子供から遠ざけてください。
2. 製品は必ず壁にしっかりと固定してください。隠された電源コード、水道管やガス管の位置を確認してから、遠く離れている壁を掘削してください。
3. 傾斜転倒の防止装置の使用は、リスクを減らすことはできますが、完全に排除することはできません。
4. 特別に設計されていない限り、この製品の上に重い物を置かないでください。
5. 一番重いものは最下位の棚に置いてください。
6. 安全のため、子供が引き出し、ドアや棚に登ったり、ぶついたりする場合はご注意ください。

CH

感谢您购买我们的产品。如果您有任何困难，请与我们联系。如遇到组装问题或需要更换零件，我们的客服团队会为您提供帮助。







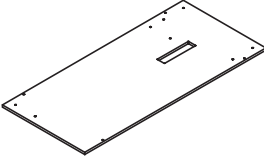
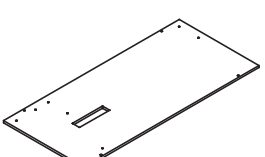
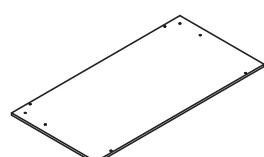
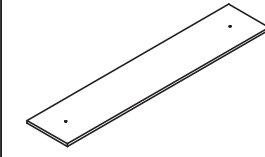
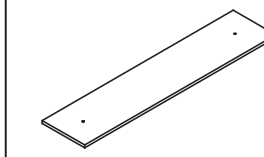
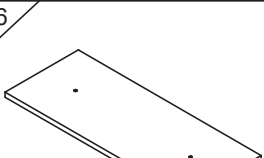
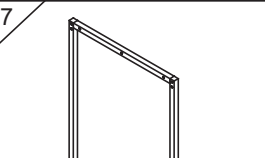
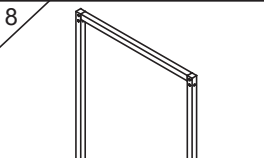
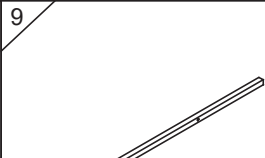
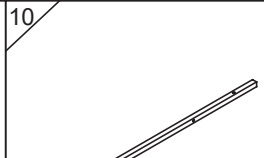

警告

产品必须由成人组装后才能使用。

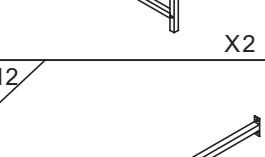
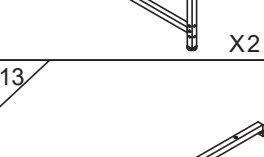
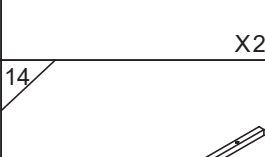
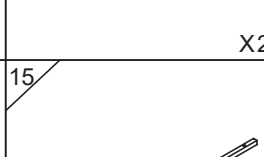



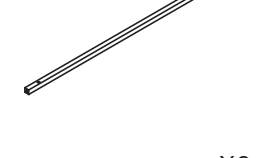
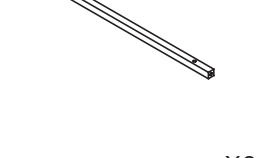
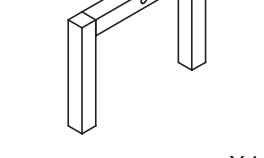

意外组装或使用可能会造成严重或致命的伤害。

1. 在组装过程中，请将所有零件远离婴幼儿。
2. 始终将本产品牢固地固定在墙上。确保钻孔的墙面远离隐蔽的电源线、水和煤气管道。
3. 使用防倾倒装置只能降低倾倒的风险，但不能消除它们。
4. 除非经过特殊设计确保可行，否则请勿在本产品上放置重物。
5. 最重的物品请放在最底层的架子上。
6. 切勿让儿童攀爬或撞击抽屉，门或架子。

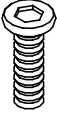
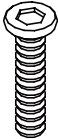
Parts List / Teile Liste

1  X1	2  X1	3  X1	4  X1	5  X2
6  X2	7  X2	8  X2	9  X2	10  X2
11  X2	12  X1	13  X1	14  X1	15  X1
16  X2	17  X2	18  X10	19  X6	20  X1
21  X2	22  X2	23  X2		

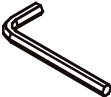
Parts List / Teile Liste

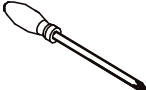
A	 M6X12 X8	 M6X23 X40	 M6X28 X44	 M4X12 X4	 M6 X23
F	 M6 X8				

Assembly Steps / Montageschritte

STEP1 The first installation

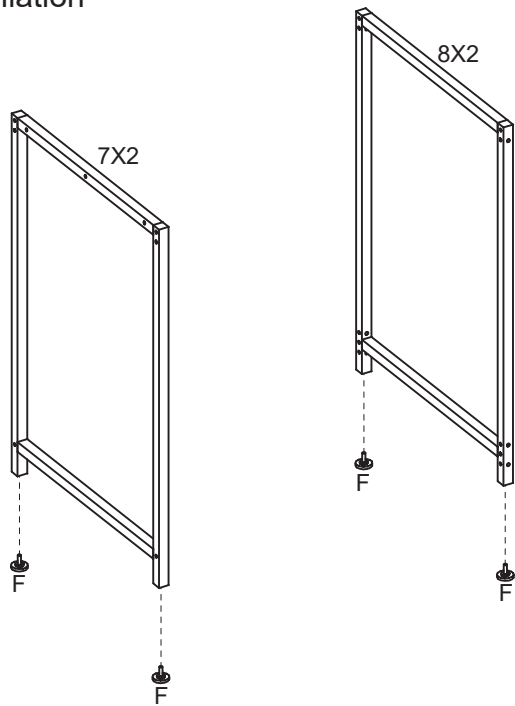

F	M6	X8
---	----	----

STEP2

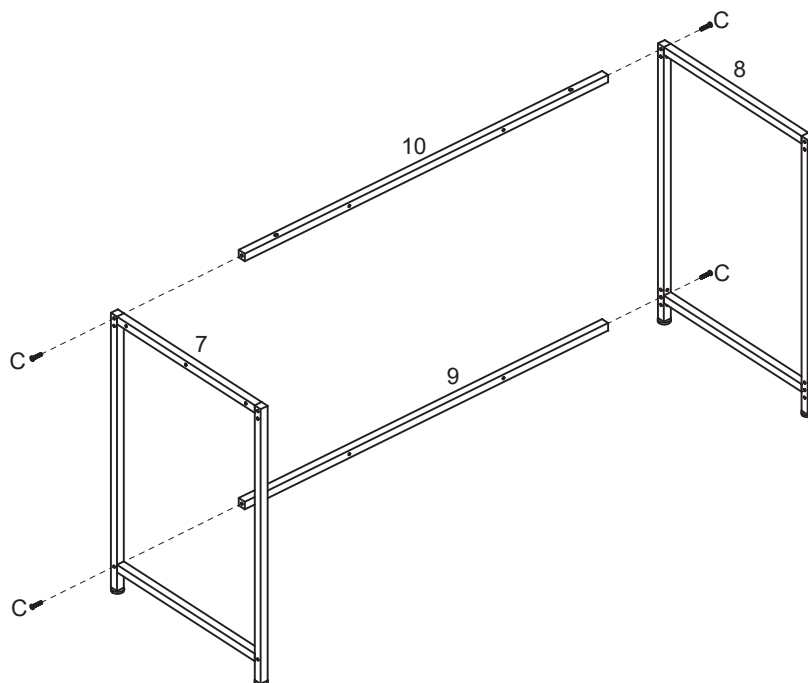

C	M6X28	X4
---	-------	----

Assembly Steps / Montageschritte

STEP 3

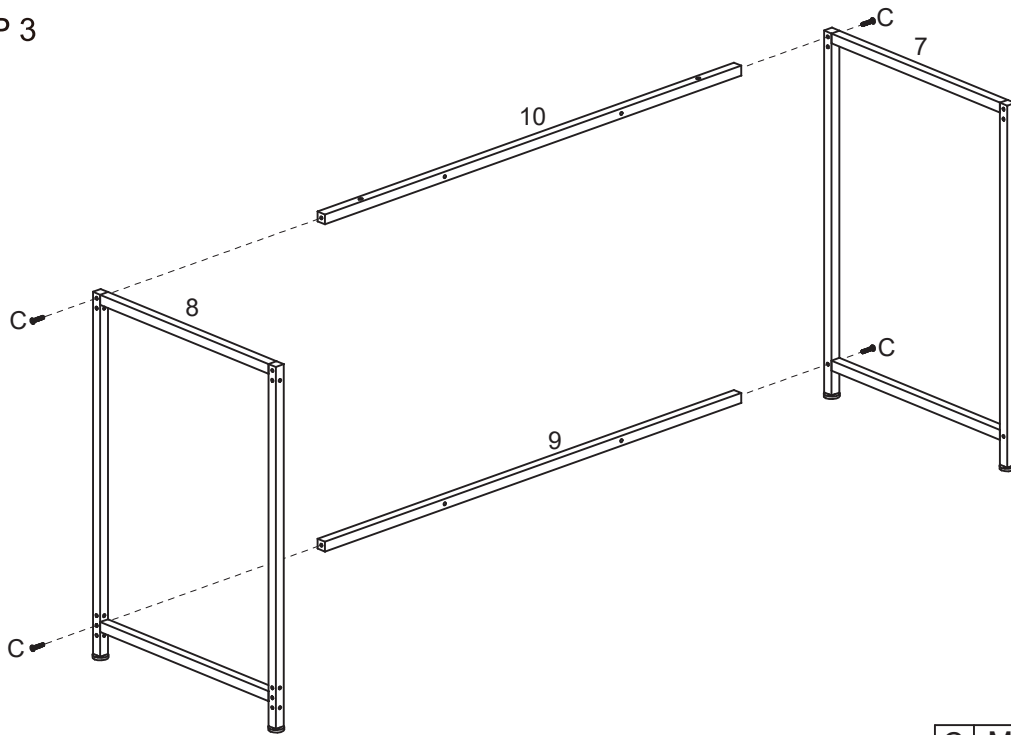

C	M6X28	X4
---	-------	----

STEP 4

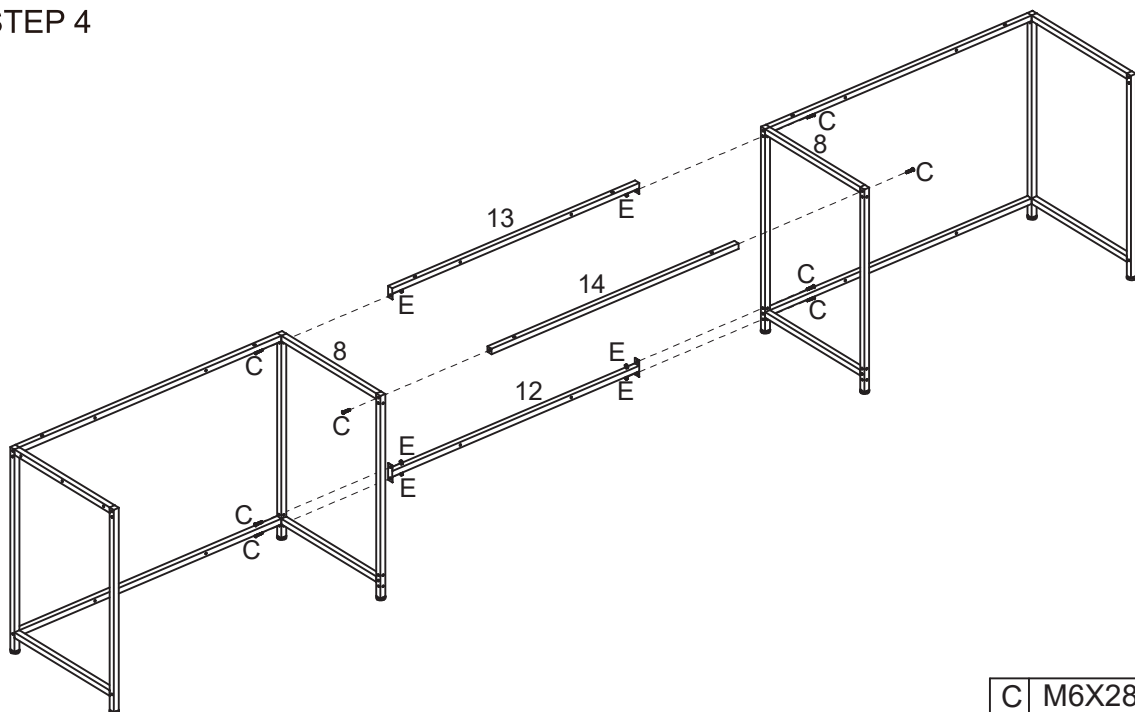

C	M6X28	X8
E	M6	X6

Assembly Steps / Montageschritte

STEP 5

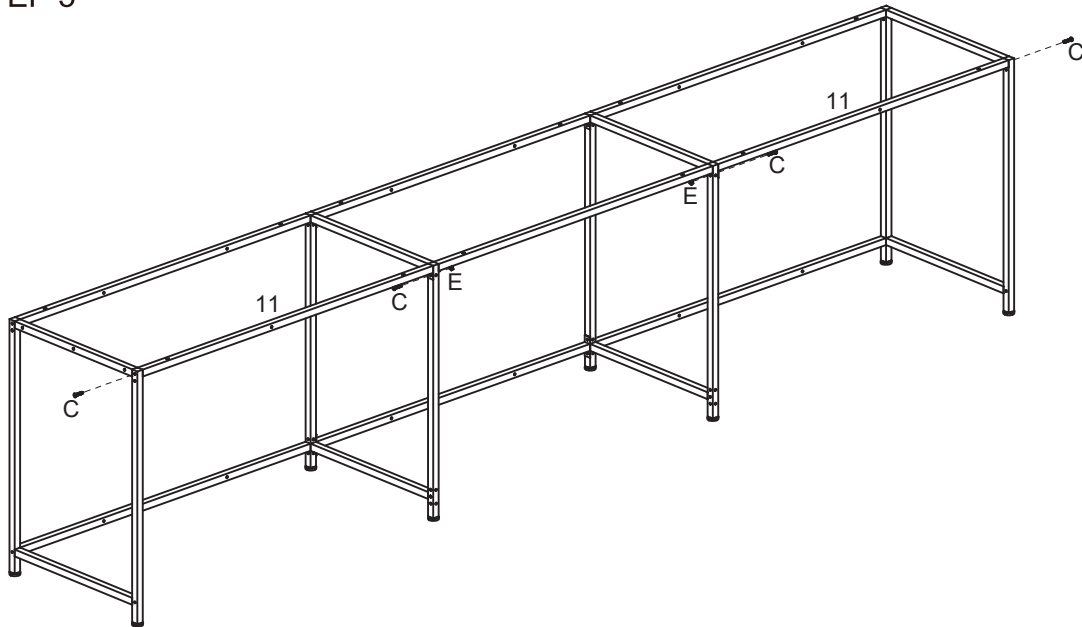

C	M6X28	X4
E	M6	X2

STEP 6

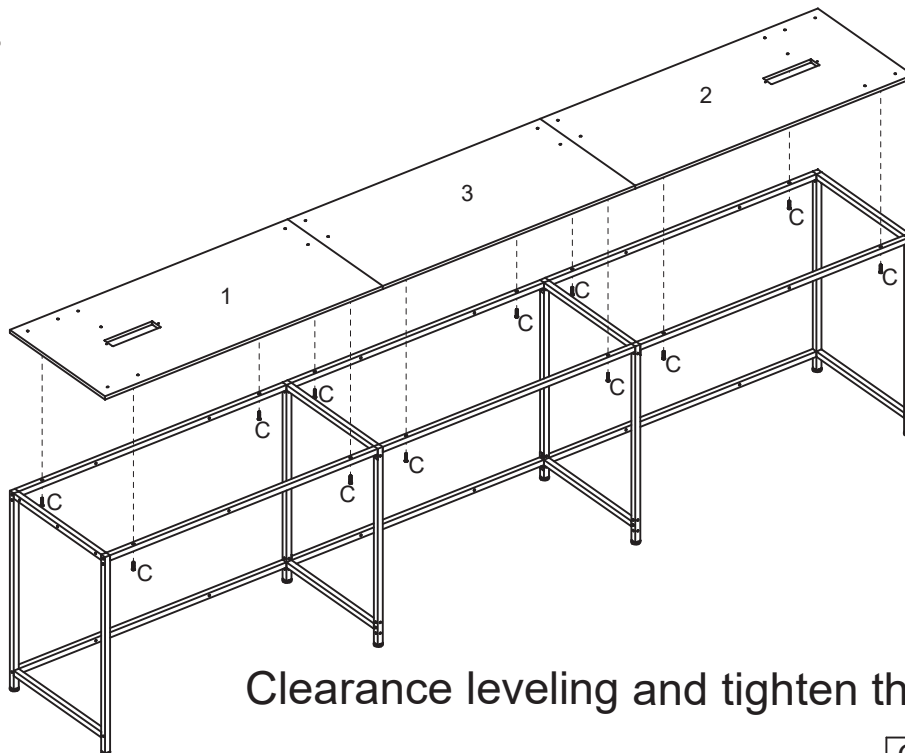

Clearance leveling and tighten the screws

C	M6X28	X12
---	-------	-----

Assembly Steps / Montageschritte

STEP 7

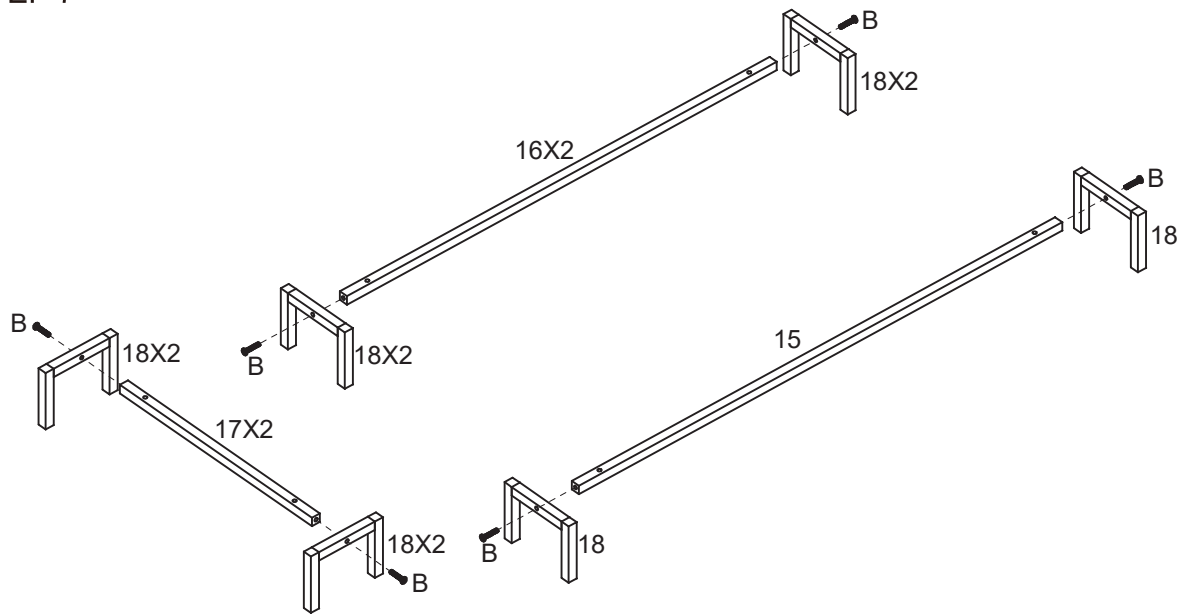

B	M6X23	X10
---	-------	-----

STEP 8

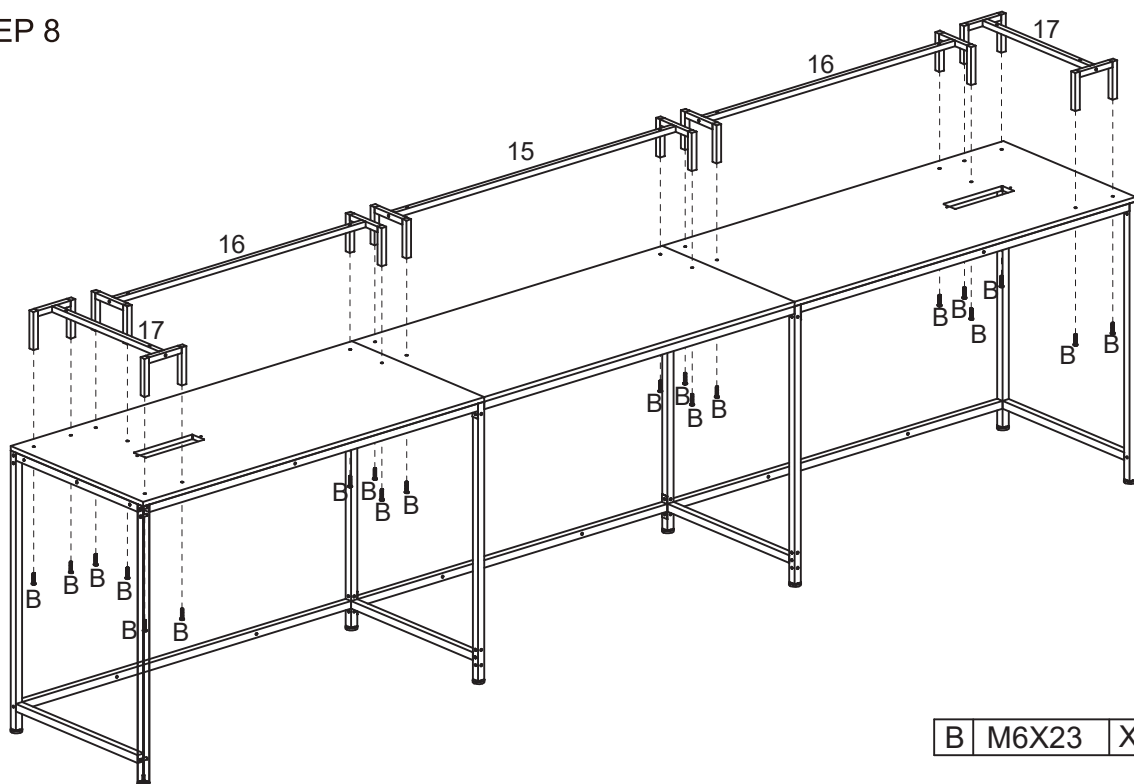

B	M6X23	X20
---	-------	-----

Assembly Steps / Montageschritte

STEP 9

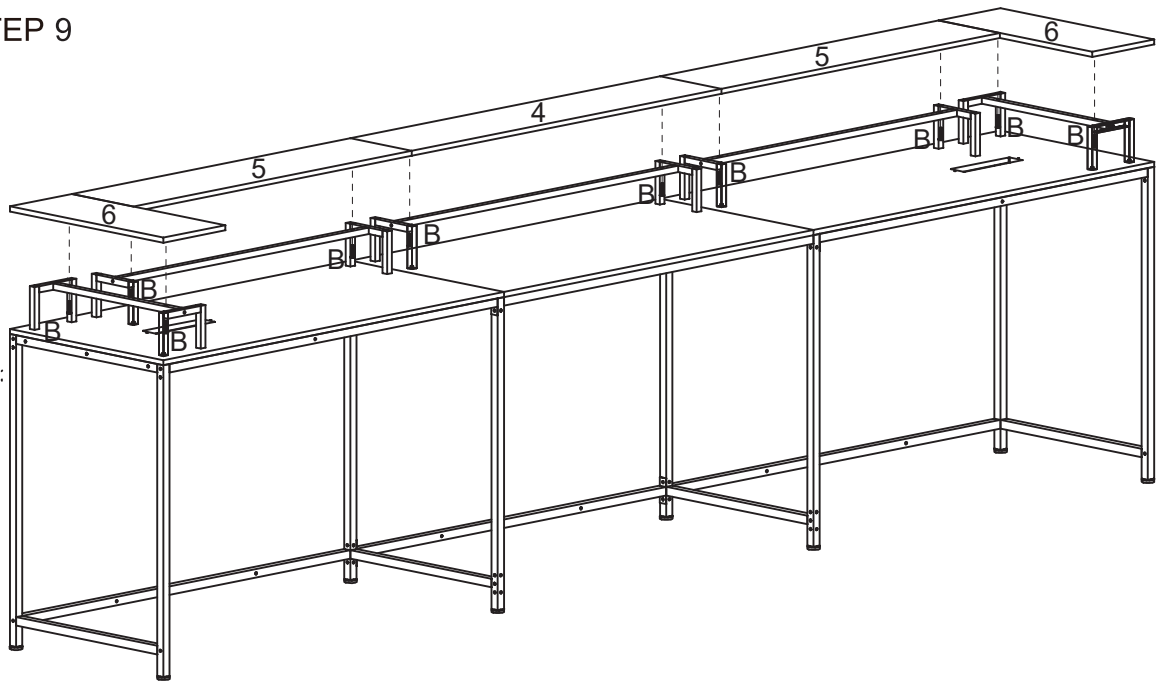

Clearance leveling and tighten the screws

B	M6X23	X10
---	-------	-----

STEP10

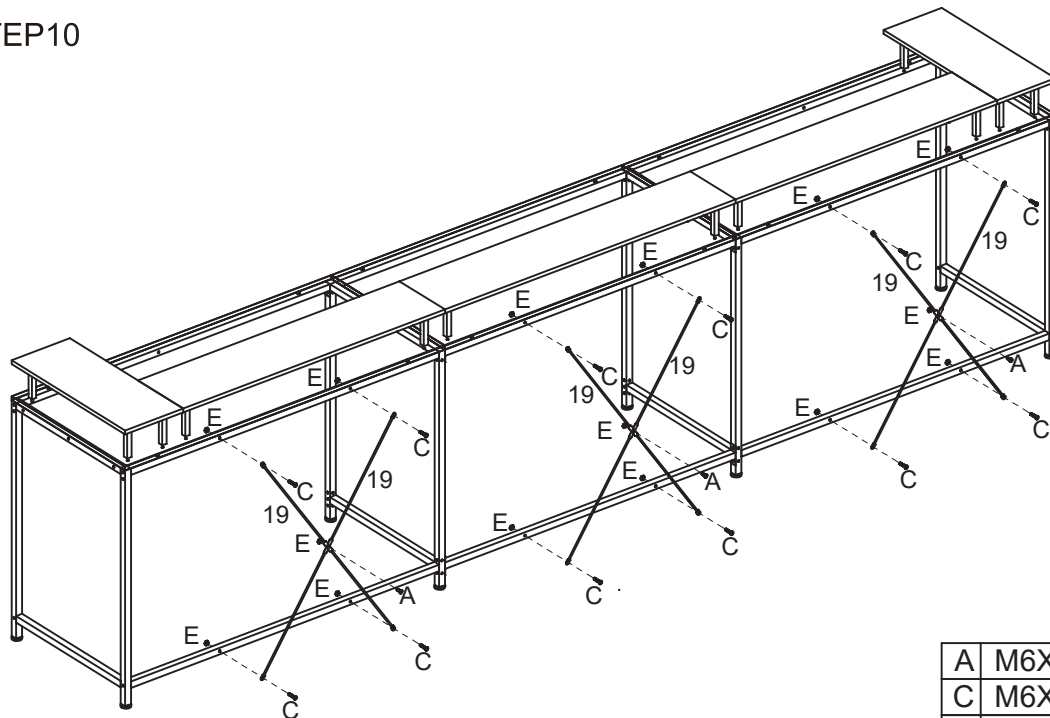

A	M6X12	X3
C	M6X28	X12
E	M6	X15

Assembly Steps / Montageschritte

STEP 13

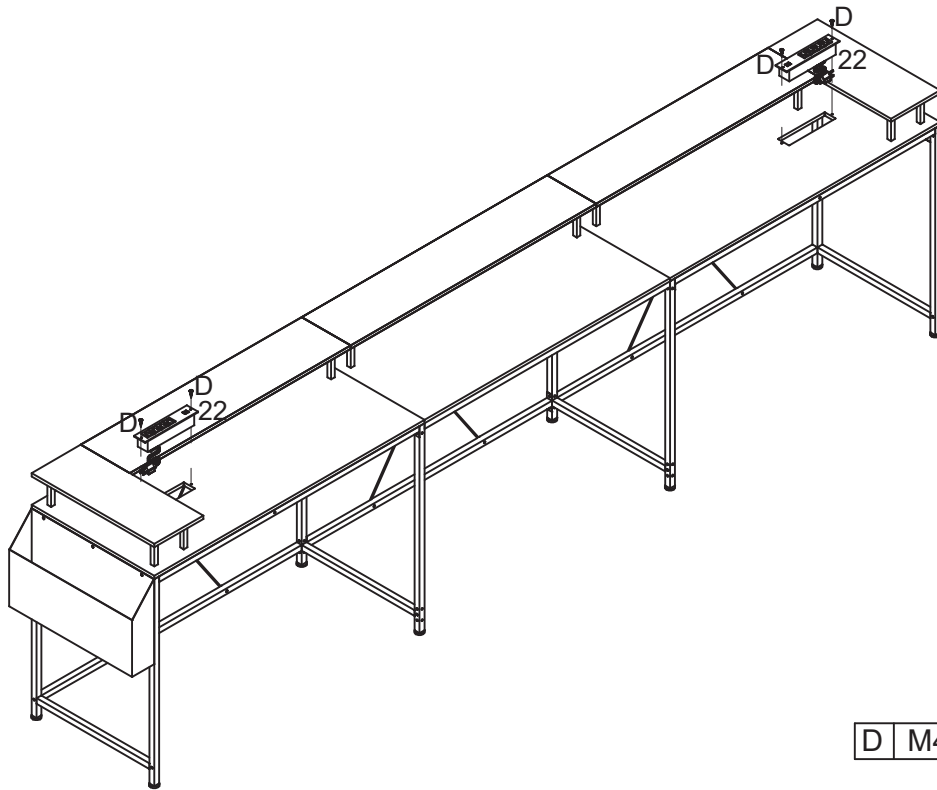

D	M4X12	X4
---	-------	----

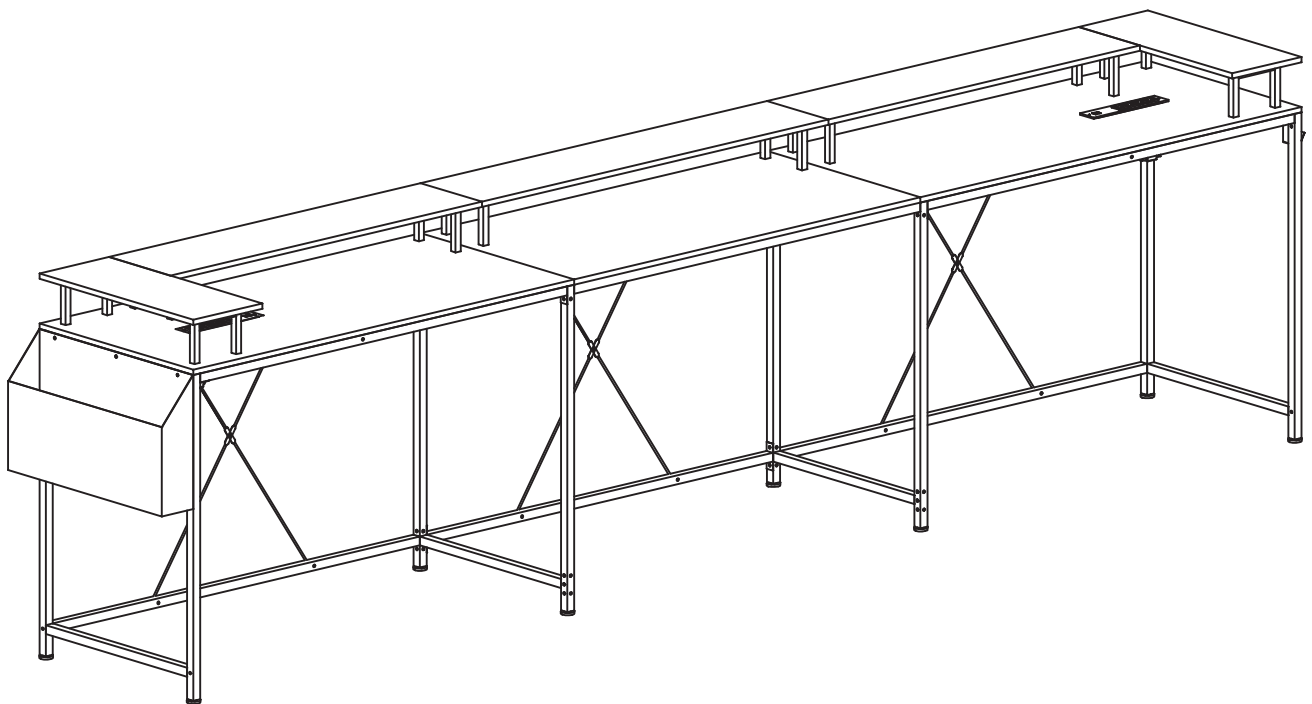

Assembly Steps / Montageschritte

STEP1 The second installation

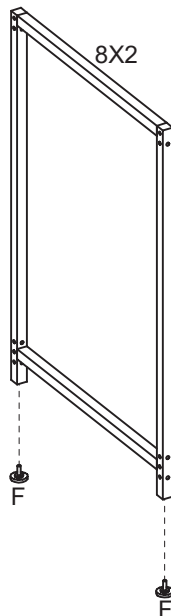
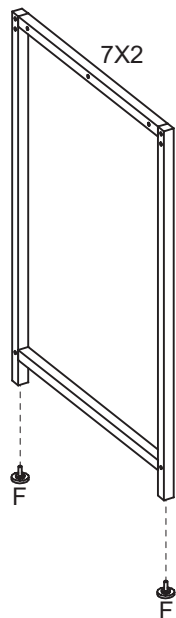

F	M6	X8
---	----	----

STEP2

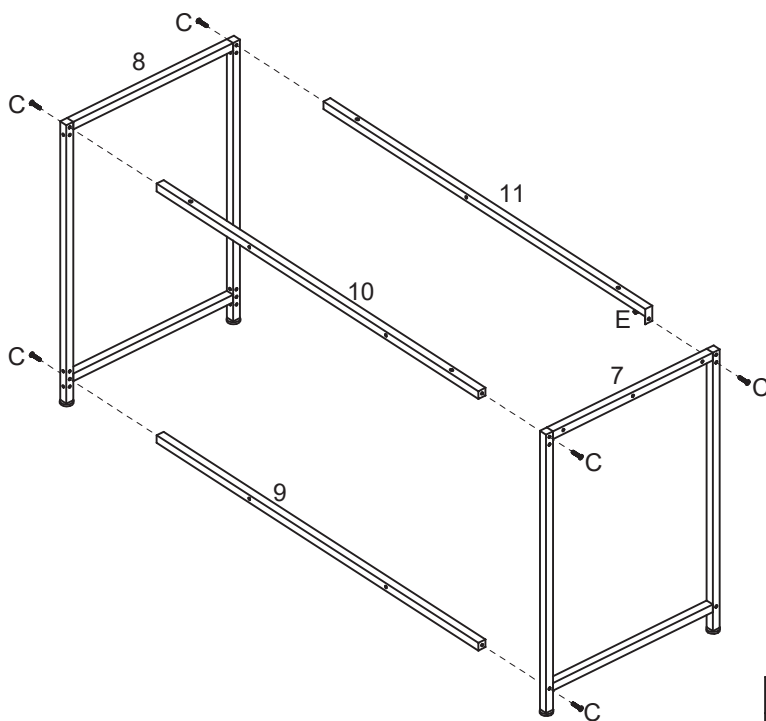

C	M6X28	X6
E	M6	X1

Assembly Steps / Montageschritte

STEP 3

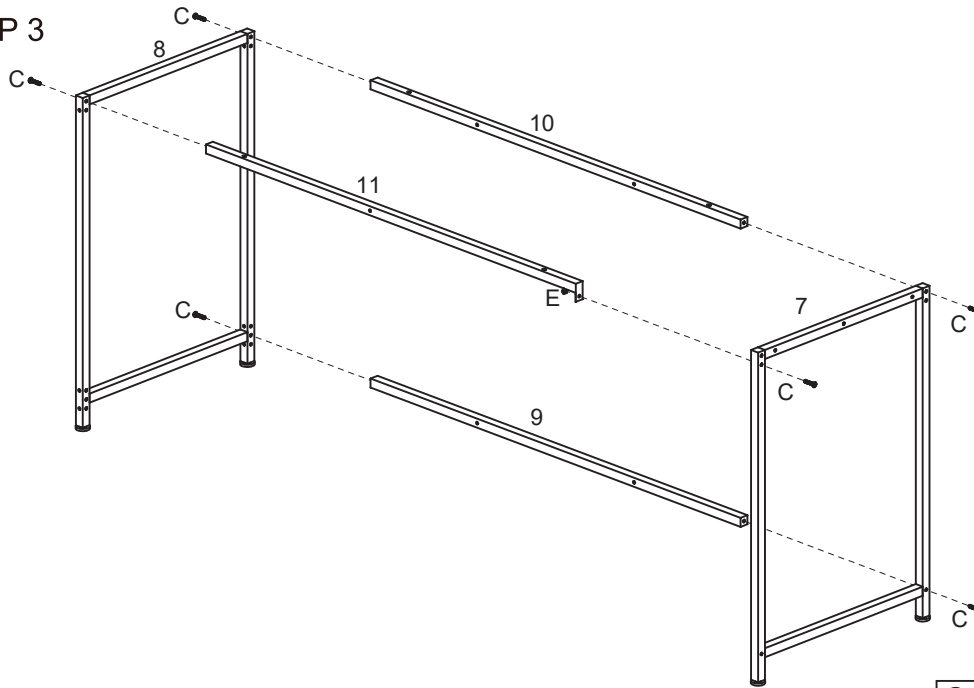

C	M6X28	X6
E	M6	X1

STEP 4

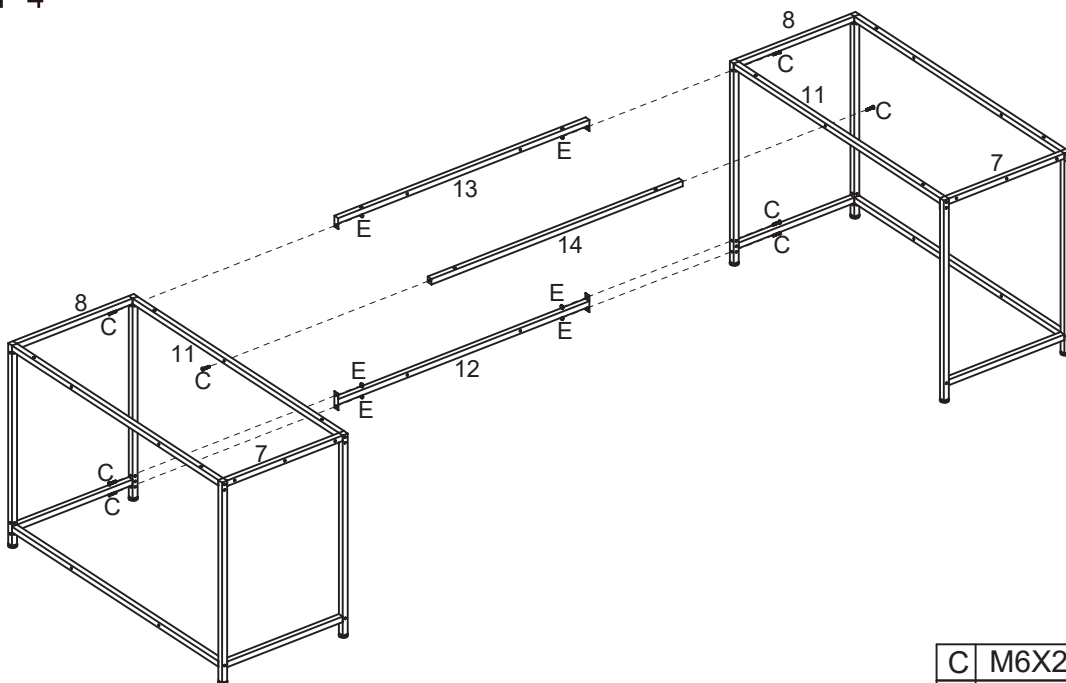

C	M6X28	X8
E	M6	X6

Assembly Steps / Montageschritte

STEP 5

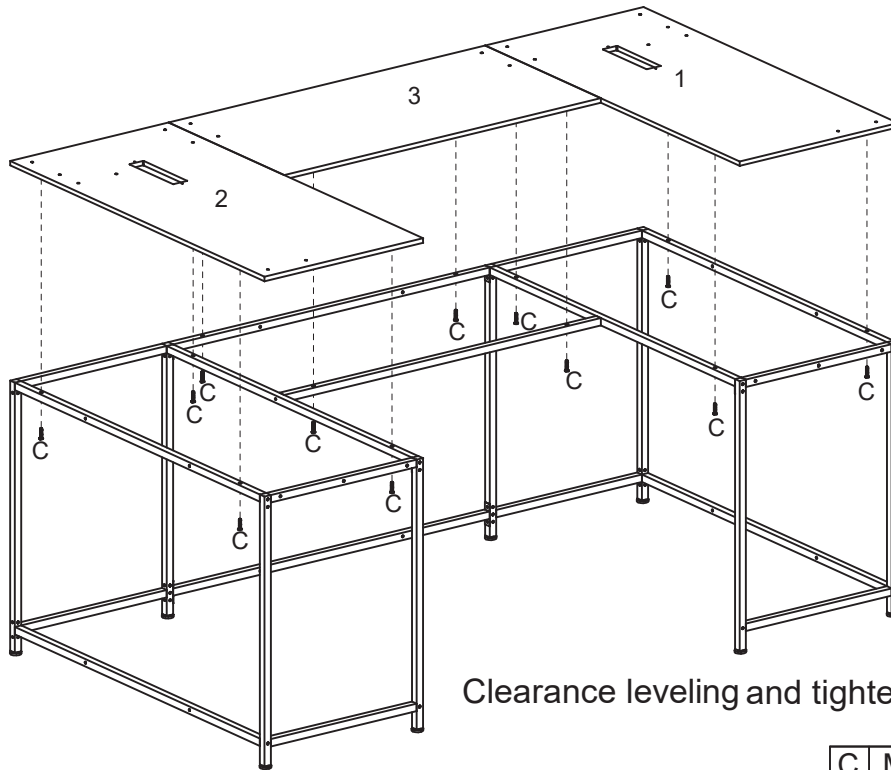

C	M6X28	X12
---	-------	-----

STEP 6

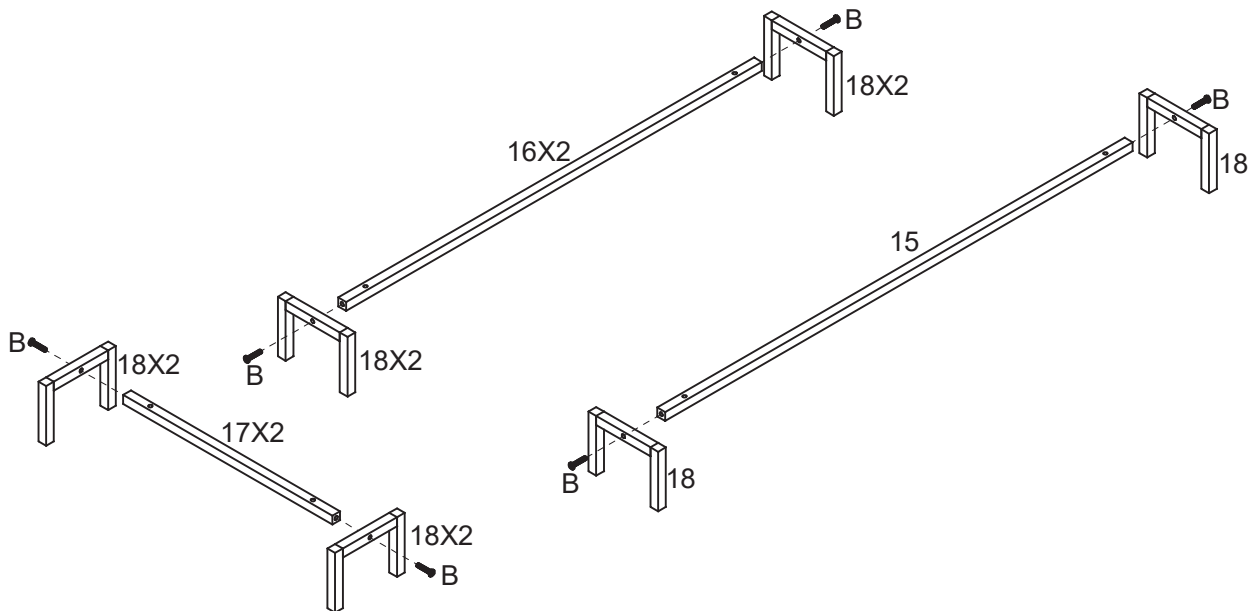

B	M6X23	X10
---	-------	-----

Assembly Steps / Montageschritte

STEP 7

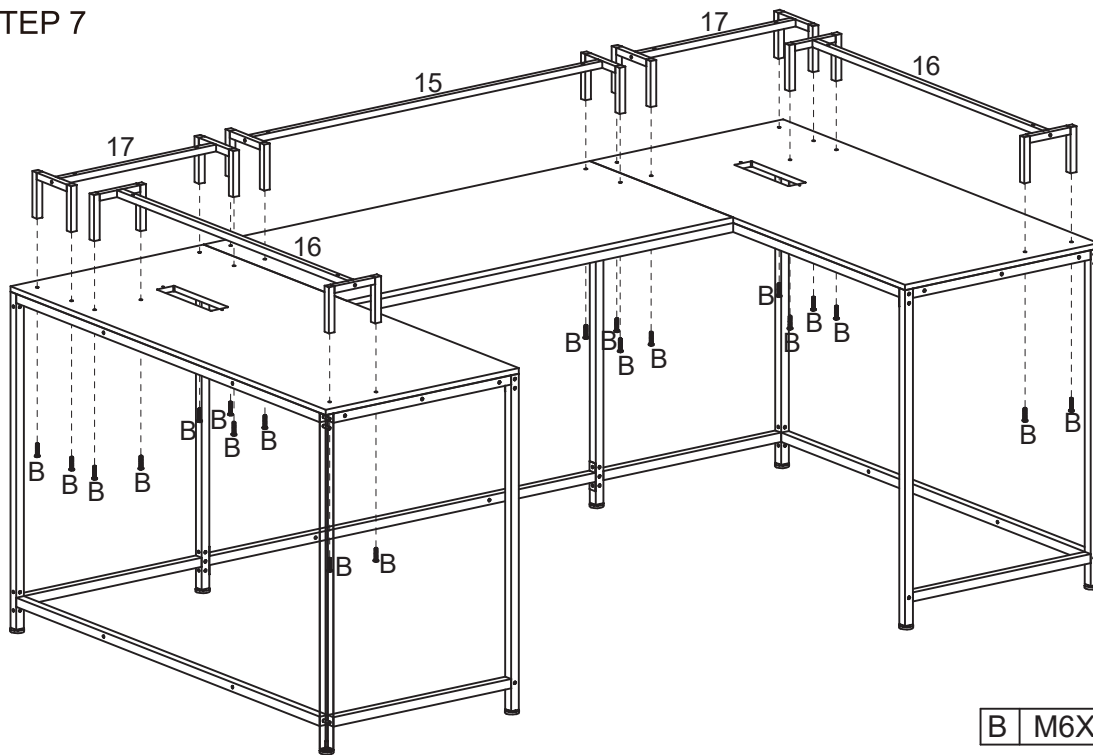

B	M6X23	X20
---	-------	-----

STEP 8

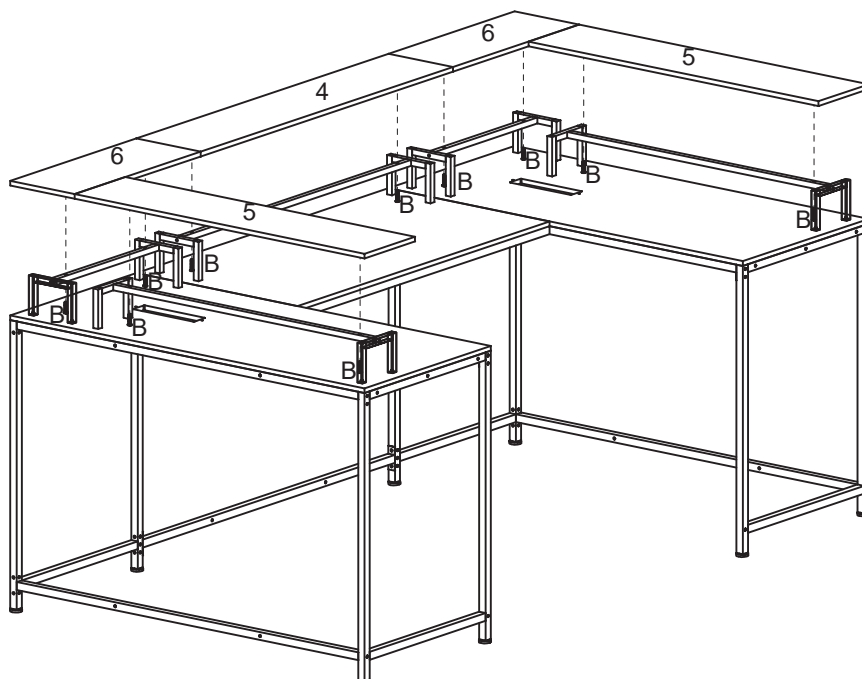

Clearance leveling and tighten the screws

B	M6X23	X10
---	-------	-----

Assembly Steps / Montageschritte

STEP 9

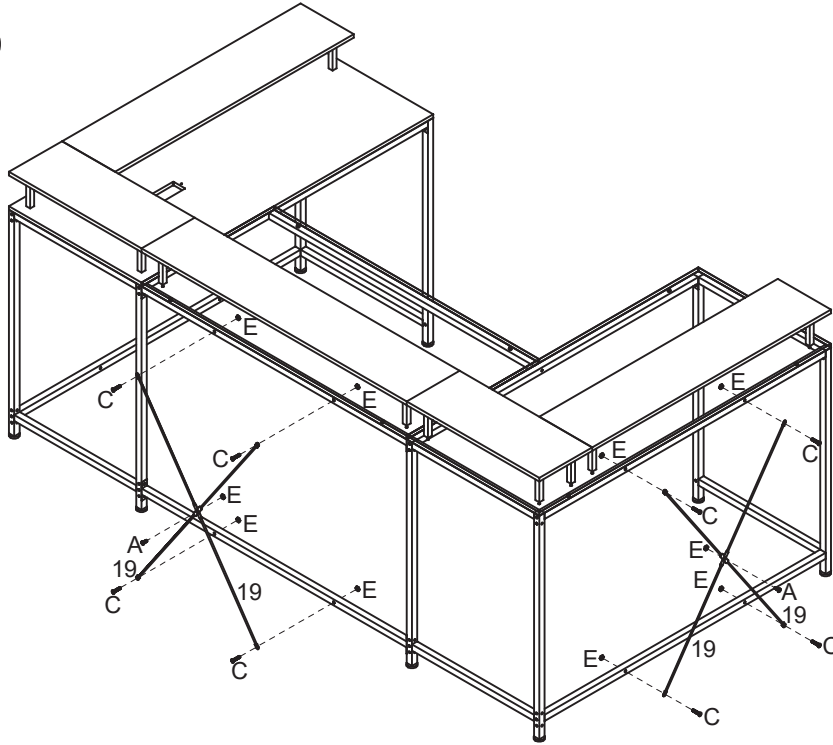

A	M6X12	X2
C	M6X28	X8
E	M6	X10

STEP 10

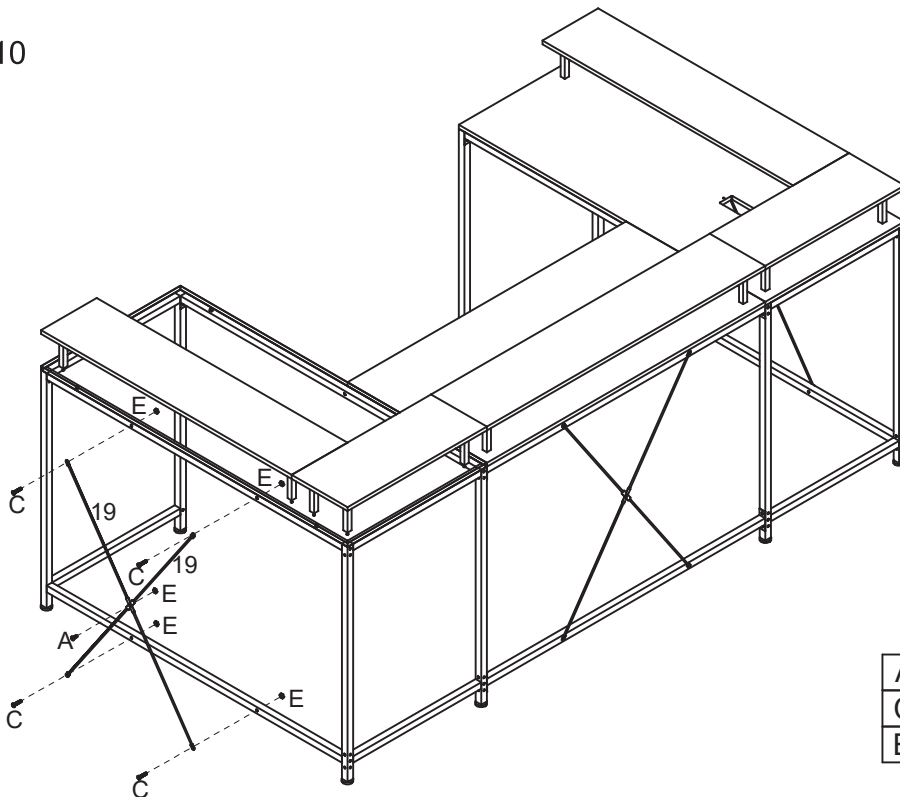

A	M6X12	X1
C	M6X28	X4
E	M6	X5

Assembly Steps / Montageschritte

STEP 11

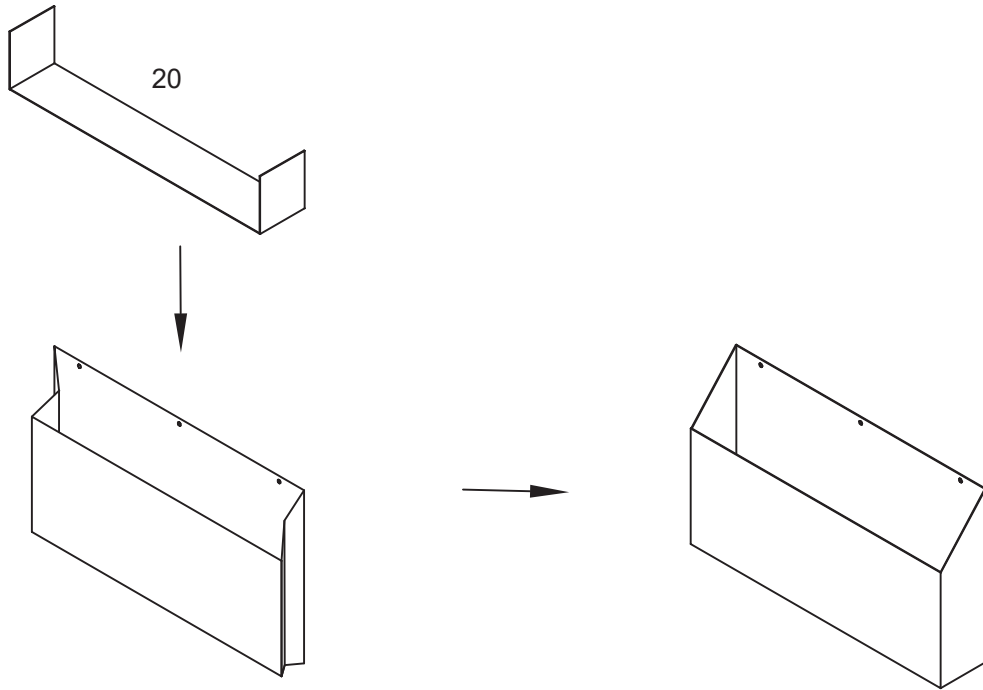

STEP 12

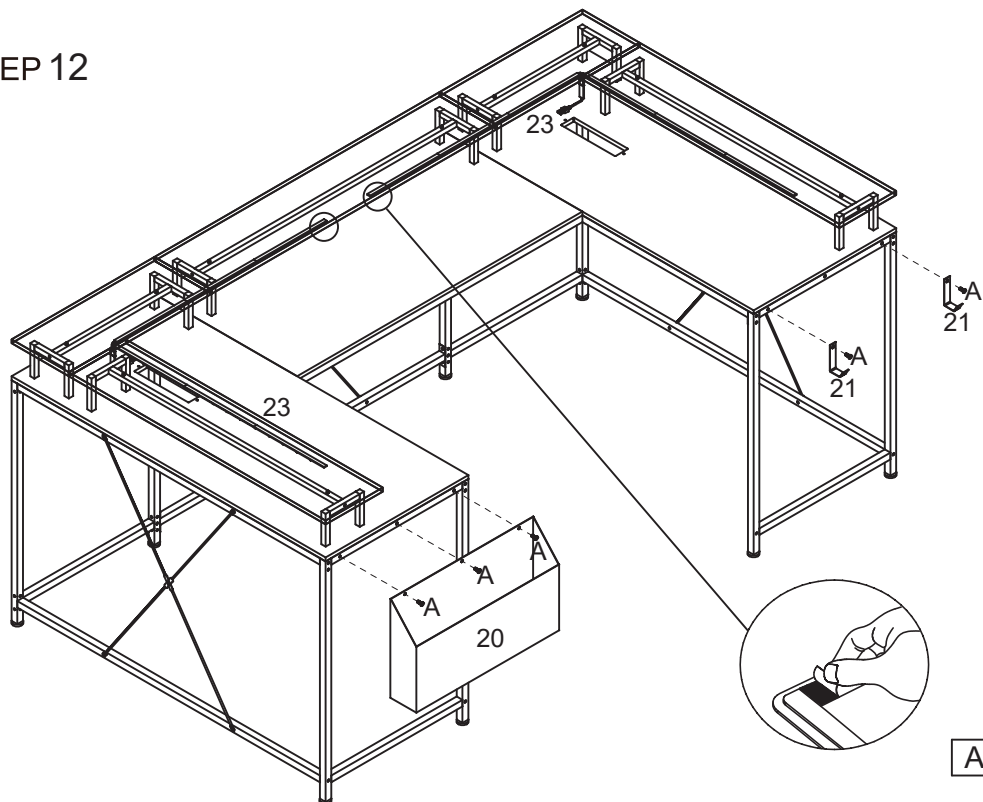

A	M6X12	X5
---	-------	----

Assembly Steps / Montageschritte

STEP 13

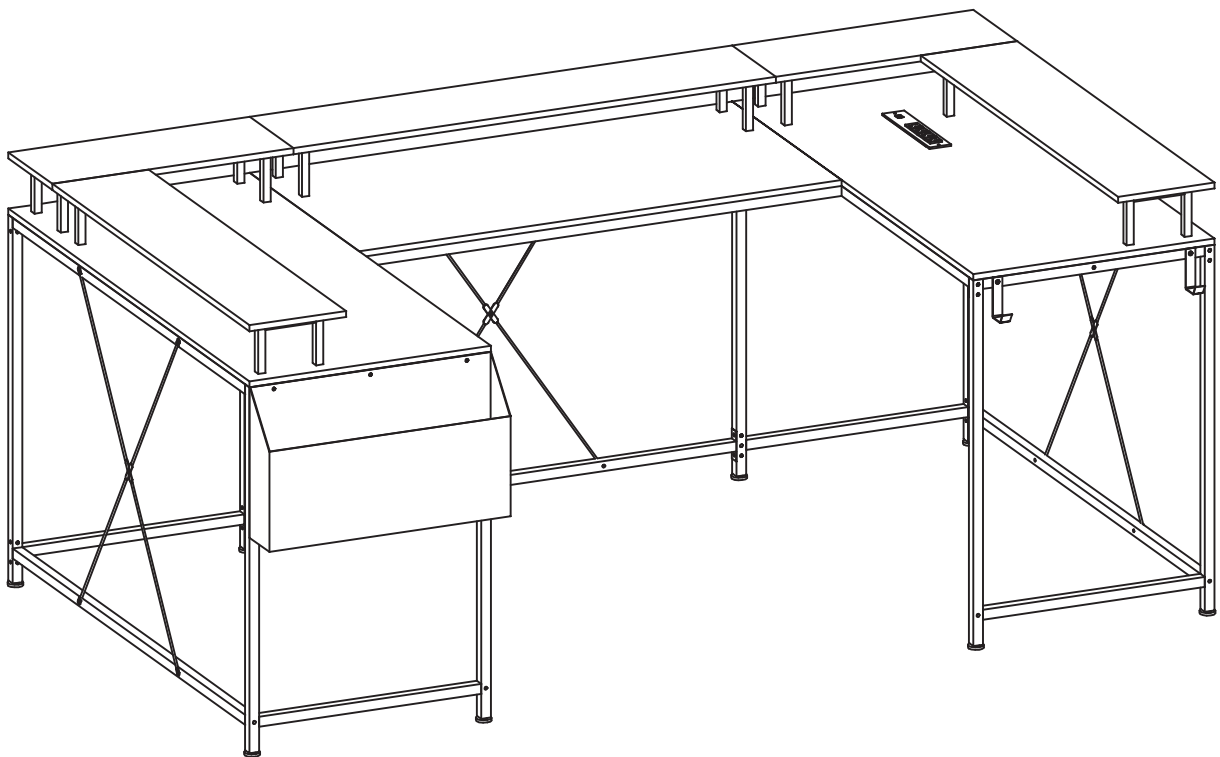
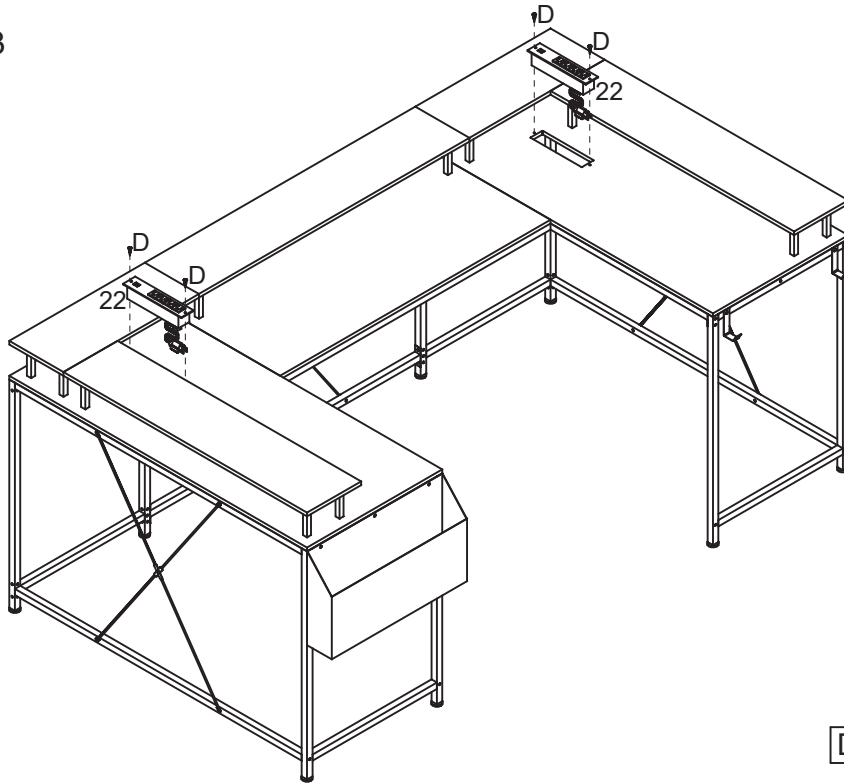

WARNING



Children have died from furniture tipover. To reduce the risk of furniture tipover:

ALWAYS install tipover restraint provided.

NEVER allow children to stand, climb or hang on drawers, doors, or shelves.

NEVER open more than one drawer at a time.

Place heaviest items in the lowest drawers.