

INSTRUCTIONMANUAL

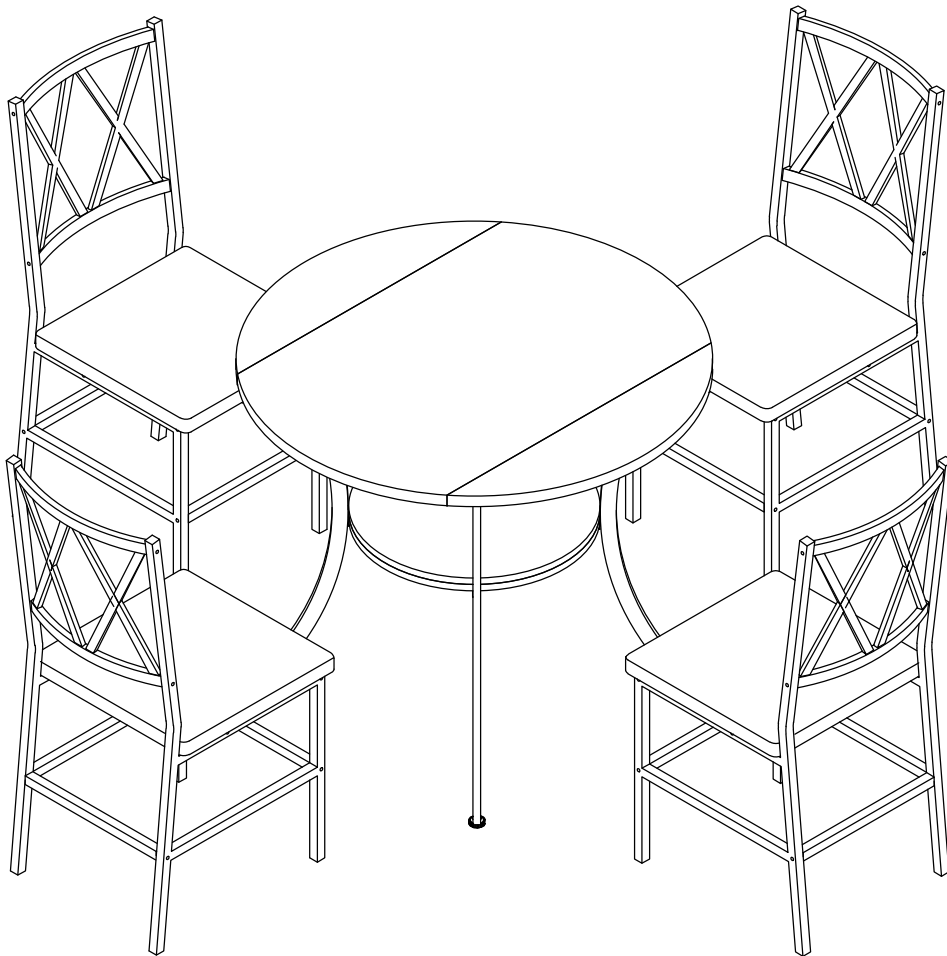

■ Please don't tighten the screws completely and go back later for a final tightening of all the screws after pieces are aligned with each other.

■ If you have any question, please feel free to contact us.



HARDWARELIST

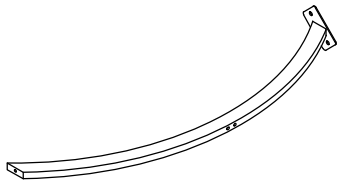

① x2PCS

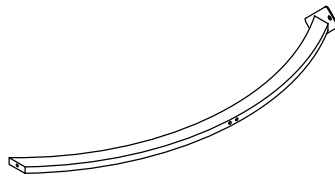

② x2PCS

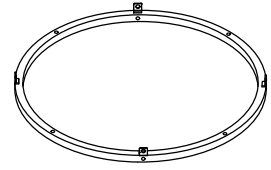

③ x1PC

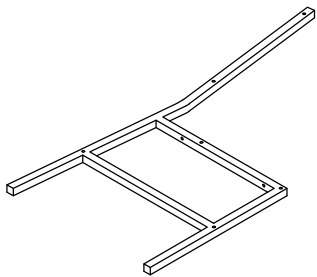

④ x8PCS

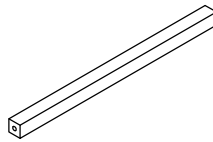

⑤ x16PCS

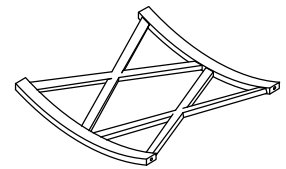

⑥ x4PCS

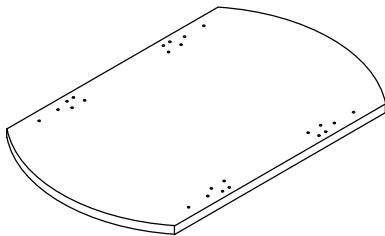

⑦ x1PC

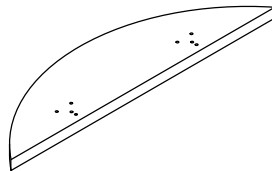

⑧ x2PCS

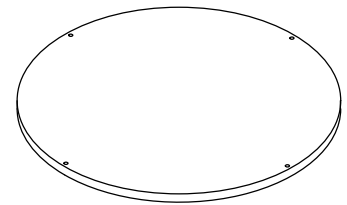

⑨ x1PC

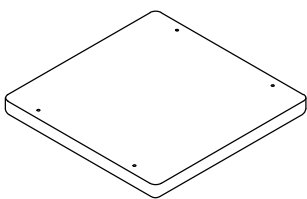

⑩ x4PCS

LISTPARTA

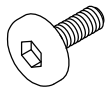

M5*16mm
A x 32PCS



M6*20mm
B x 12PCS

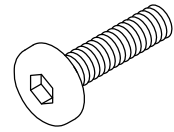

M6*25mm
C x 8PCS

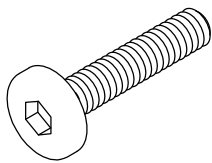

M6*30mm
D x 48PCS

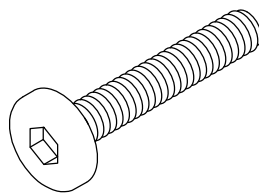

M6*35mm
E x 16PCS

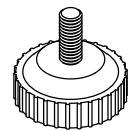

F x 4PCS

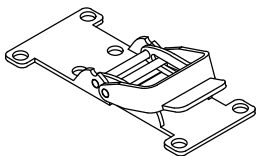

G x 4PCS

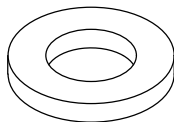

H x 8PCS

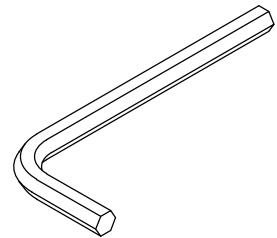

I x 1PC

1

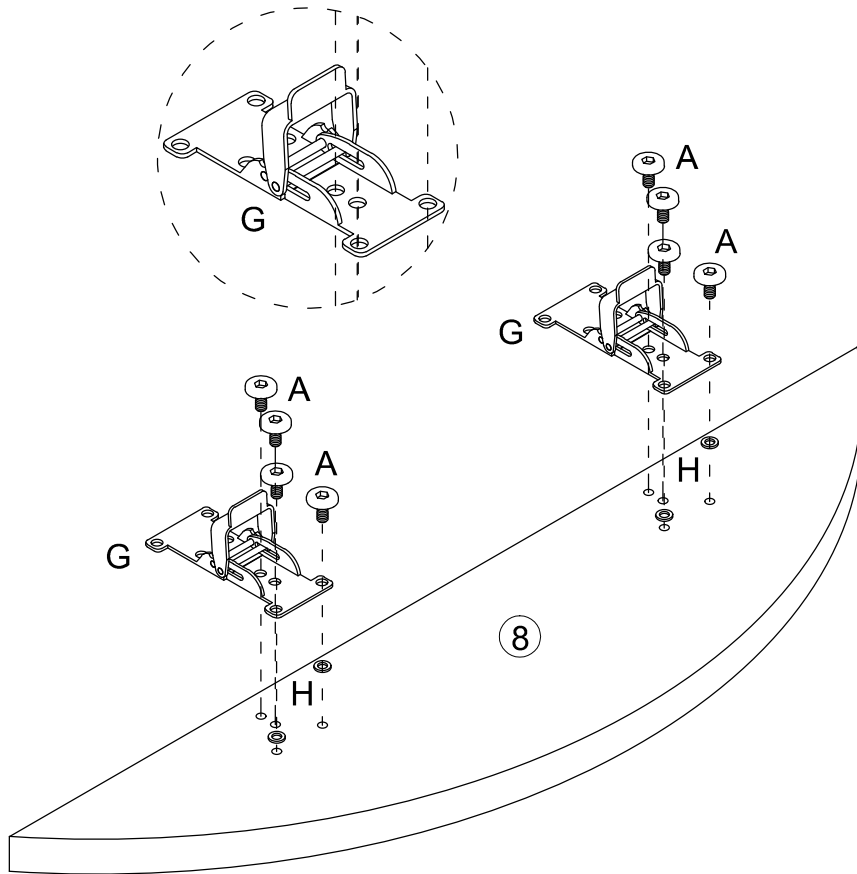

8		2PCS
A		16PCS
G		4PCS
H		8PCS
I		

x 2

2

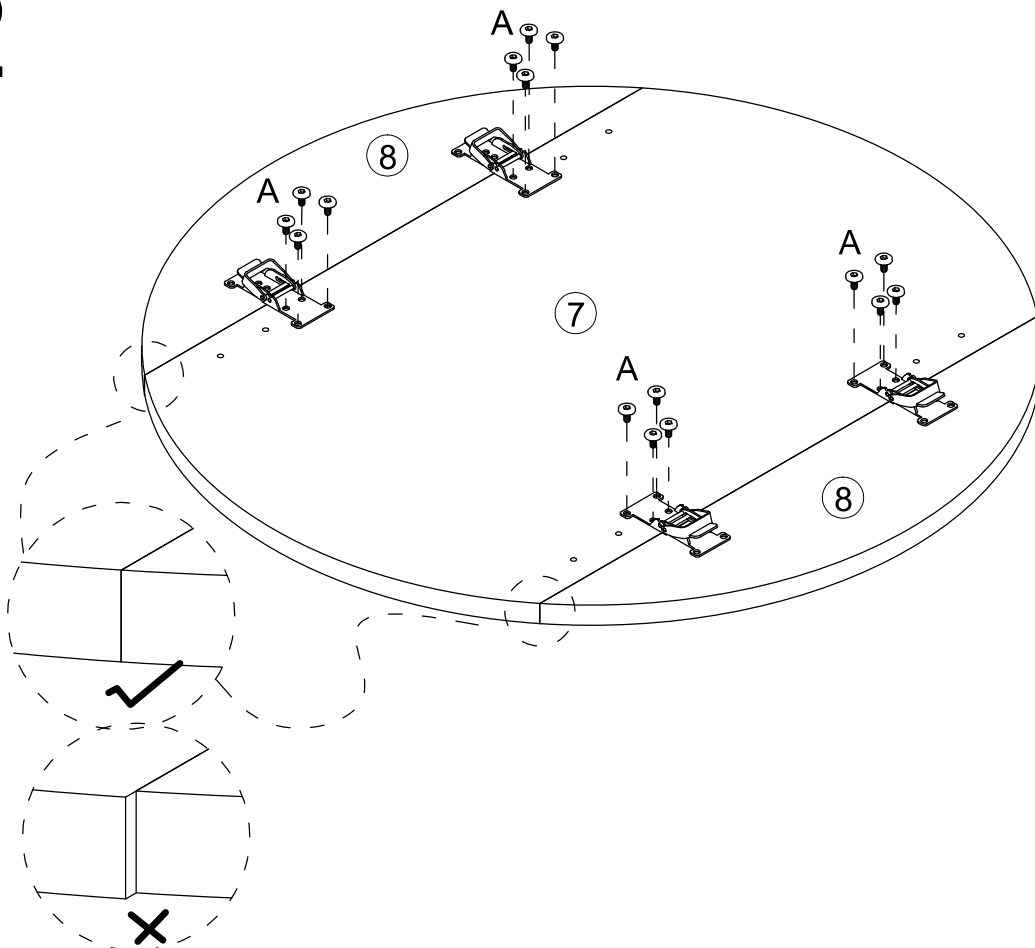

7		1PC
A		16PCS
I		

3

NOTE: Please do not fully tighten the screws.

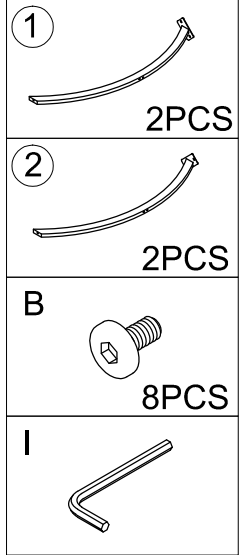
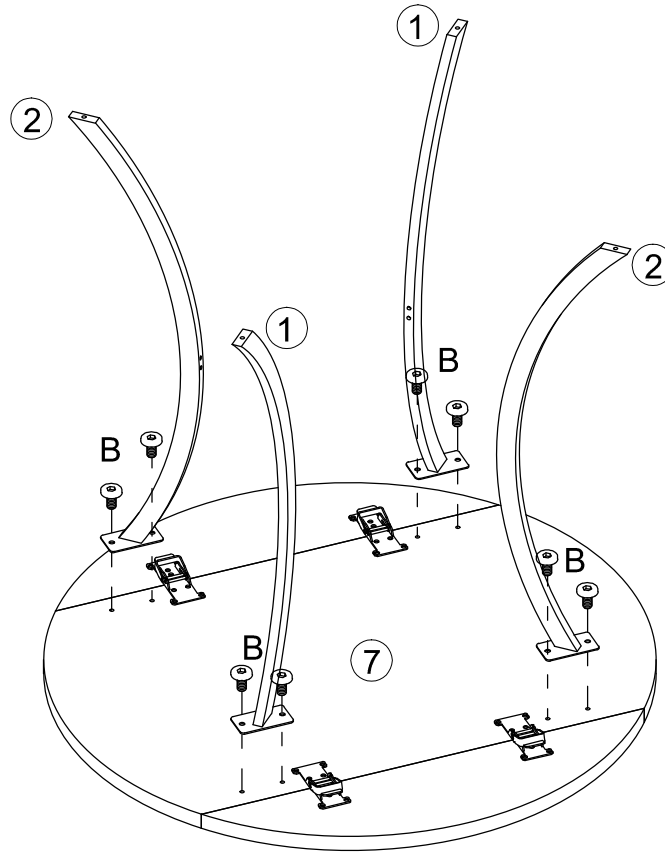

4

NOTE: Please do not fully tighten the screws.

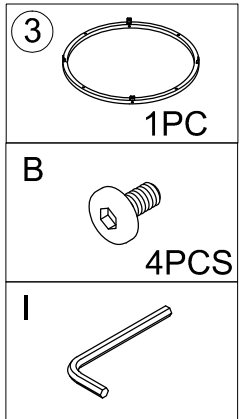
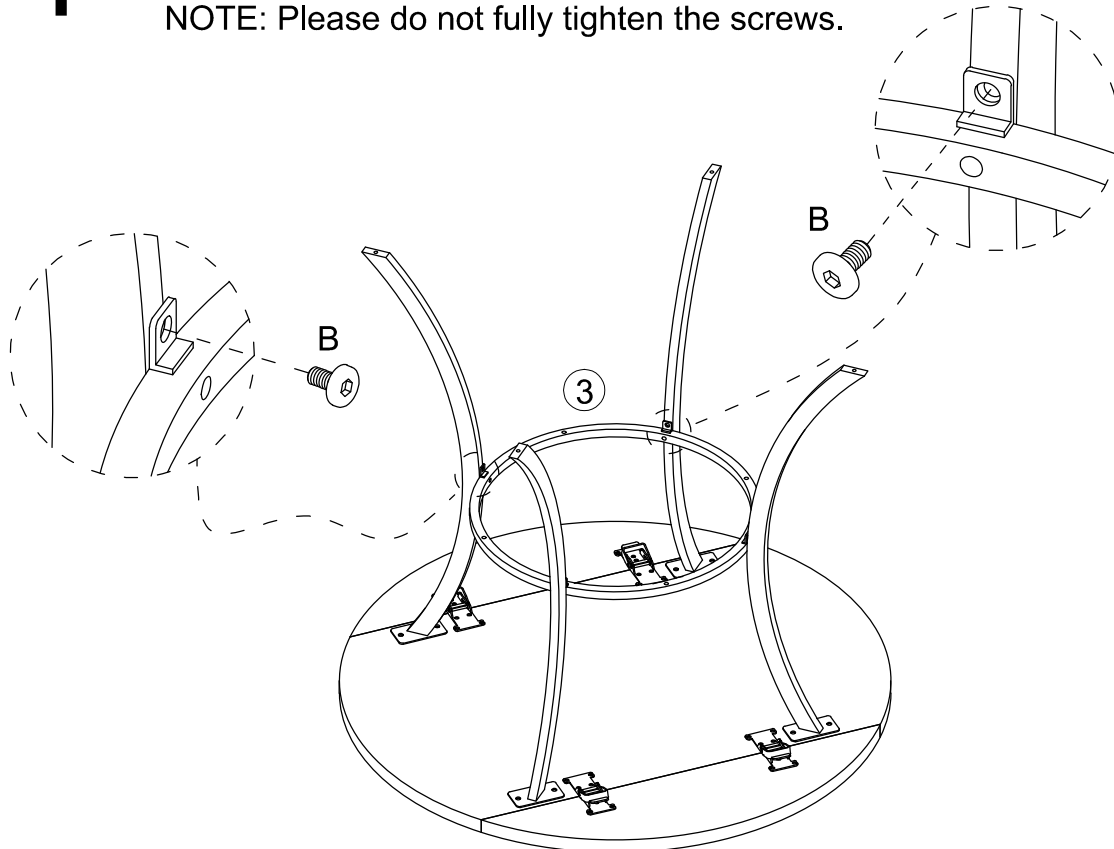

5

NOTE: When all C screws are used in their respective positions, all screws can be tightened.

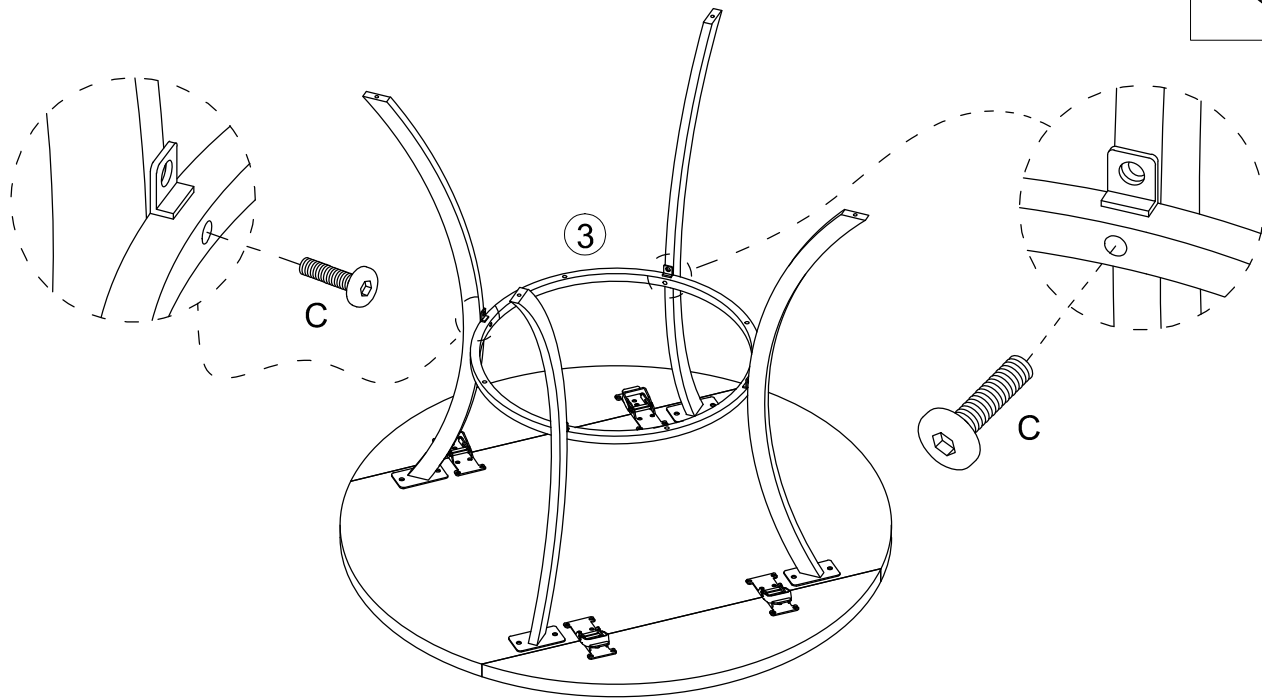
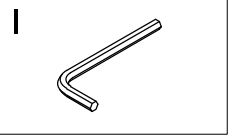
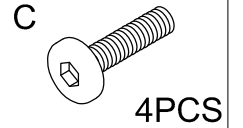

6

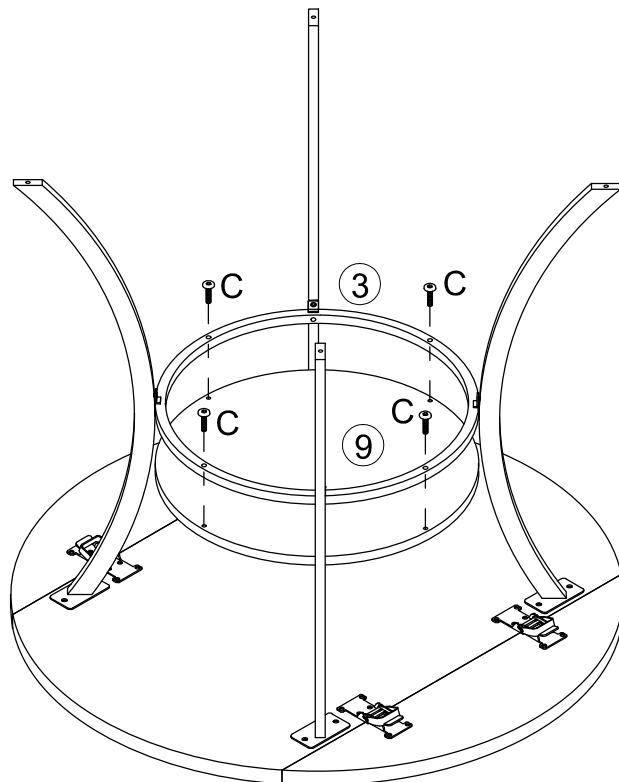
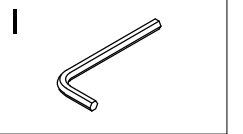
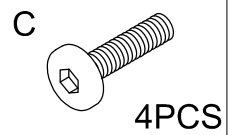
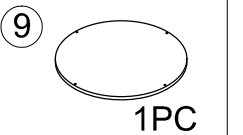

7

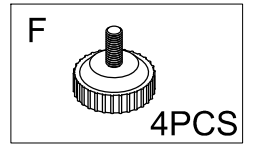
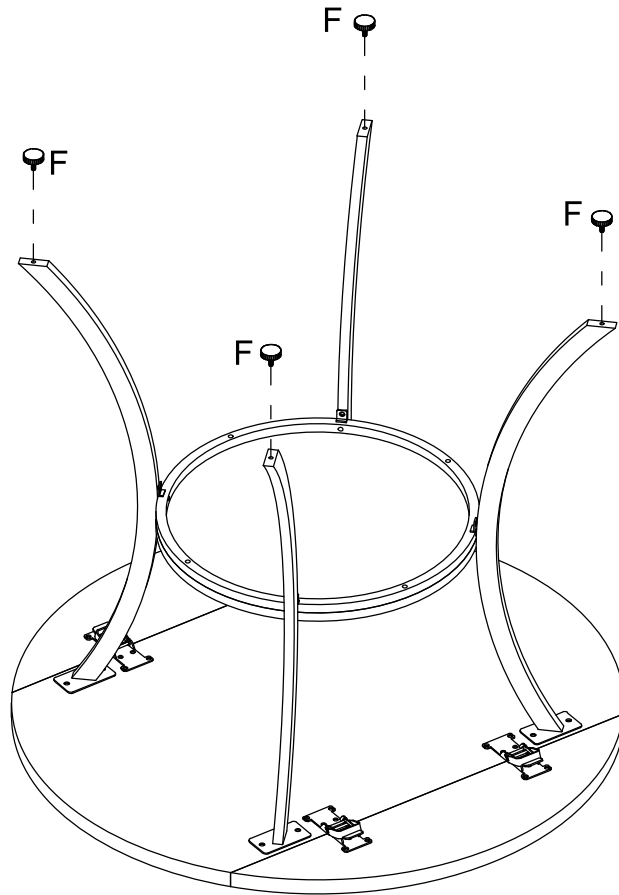

8

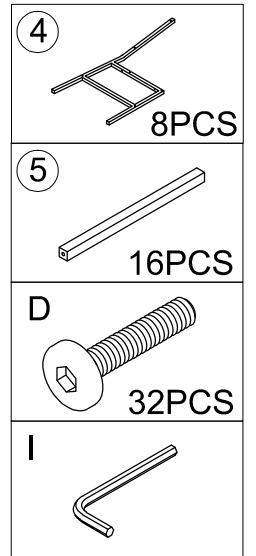
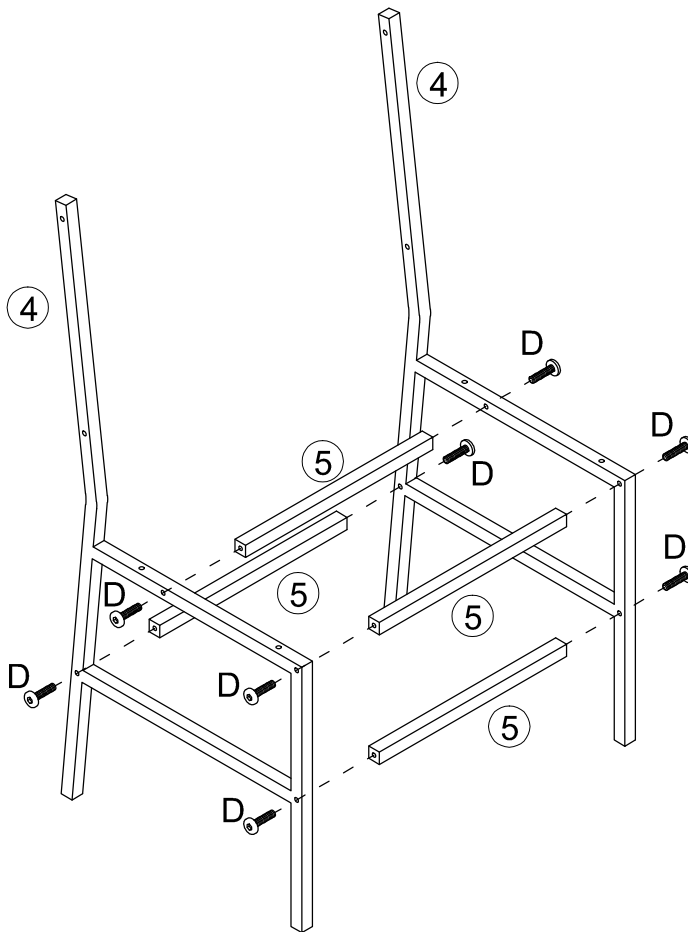

x 4

P7

9

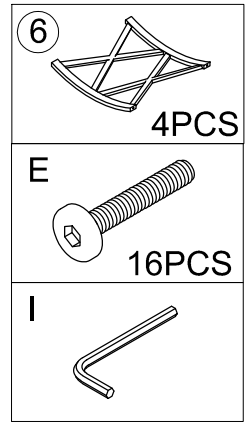
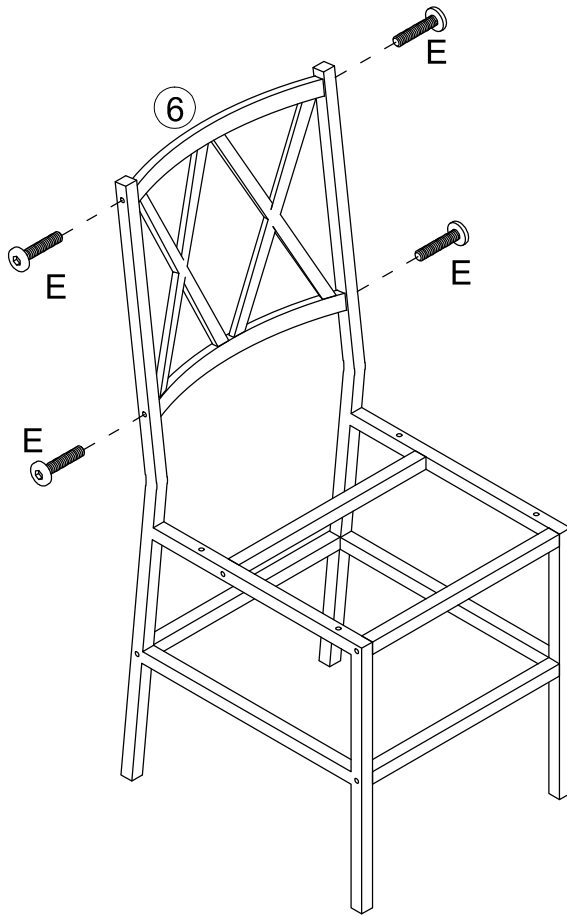

x 4

10

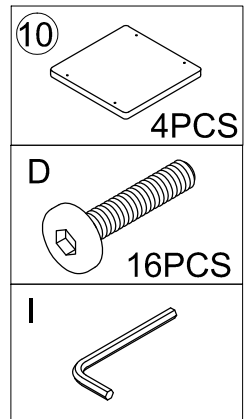
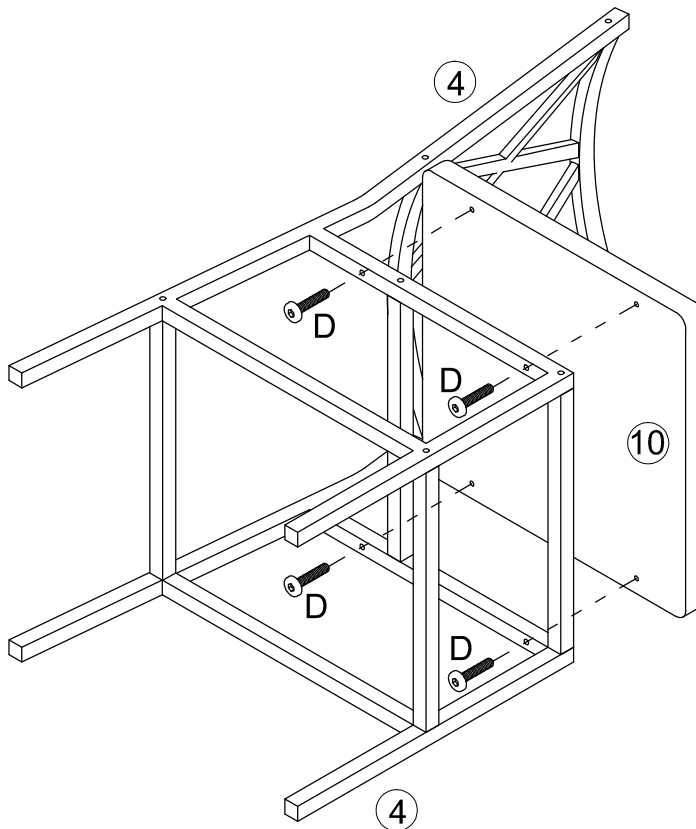

x 4

11

