

ASSEMBLY INSTRUCTIONS

DINING TABLE

ASSEMBLY
REQUIREMENTS

2-Person
Assembly

30 MINUTES
Assembly Time
(Approximate)

Thank you for purchasing our product!

Please refer and use this assembly instruction to assemble the product. Contact our customer service department in case there are any missing or damage parts or hardware. Replacement parts are normally shipped within 2 or 3 days.

We appreciate your business!

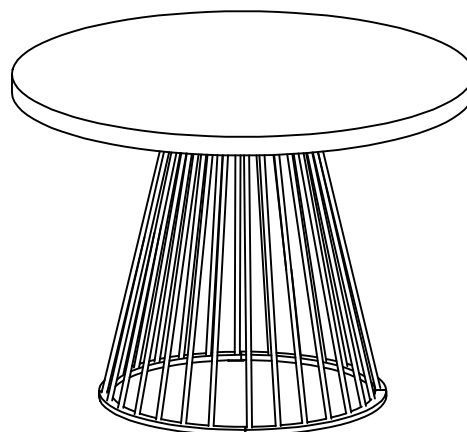

ASSEMBLY PREPARATION

1. Remove all packaging materials, staples and packing straps from the carton.
2. Refer to Parts List and Hardware List, and ensure parts and hardware are correct before assembly. Contact customer service for missing parts.
3. Place all wooden parts on a clean, flat and soft surface (e.g. carpet or rug) to prevent scratch and damage to parts.

SAFETY PRECAUTION

1. KEEP ALL HARDWARE PARTS OUT OF REACH OF CHILDREN.
2. DISPOSE PLASTIC PACKAGING MATERIAL IMMEDIATELY TO AVOID ANY RISK OF SUFFOCATION TO CHILDREN AND ANIMALS.

TIPS FOR ASSEMBLY

1. Allow ample room for assembly and in close proximity to where product will be placed.
2. Assemble the product on a surface that does not scratch or damage the exterior gloss and finish of the furniture.
3. Identify all of the parts, hardware and quantities required for each step.
4. During assembly, do not over-tighten any fittings as this may cause damage.
5. DO NOT USE POWER TOOLS TO ASSEMBLE THIS PRODUCT.
6. Always place the product on a flat, level surface.
7. Do not sit or stand on the partially assembled product; only use the product for which it is intended.

CARE AND MAINTENANCE







- Use a slightly damp cloth to clean the product. Do not use bleach or abrasive cleaning material.
- Check all the fittings periodically and re-tighten as necessary. Do not use the product if any of the parts is damaged or broken.
- Never allow any kind of liquid to remain on your furniture. Absorption can cause wood to warp or delaminate.
- Do not place hot items (e.g. hot drinks) directly onto the wood surface.
- Do not drag and/or pull the furniture.

This product is for indoor and household use only - not for commercial use.

ASSEMBLY INSTRUCTIONS

DINING TABLE

PARTS & HARDWARE LISTS

A		Table Top	1PC	D		Bolt	12PCS
B		Leg	4PCS	E		Bolt	4PCS
C		Brace Plate	4PCS	F		Allen Key	1PC

STEP 1

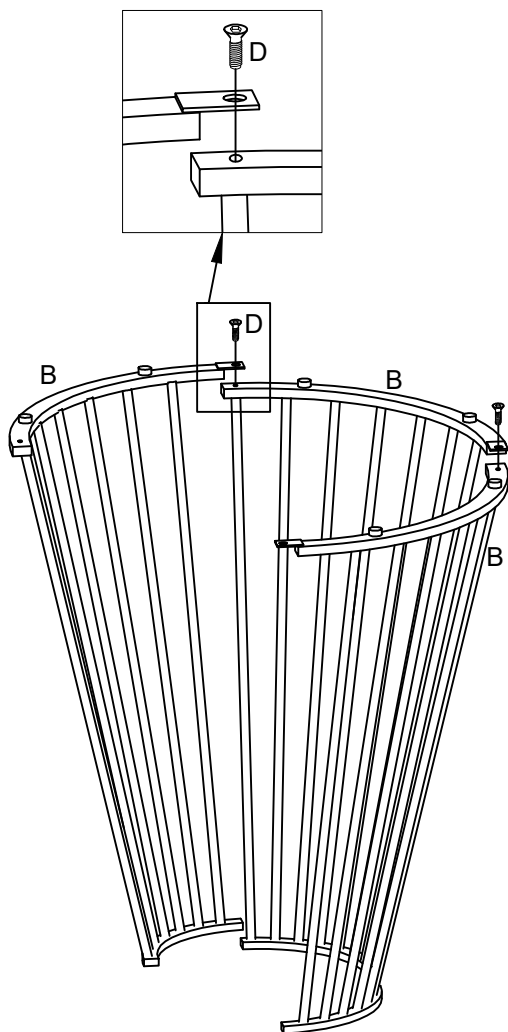

- a) Position 3 pieces of Leg (B) as shown. Note how each leg over-lap each other.
- b) Use Screw (D) to fasten the legs. Do not tighten the screw completely at this time.

STEP 2

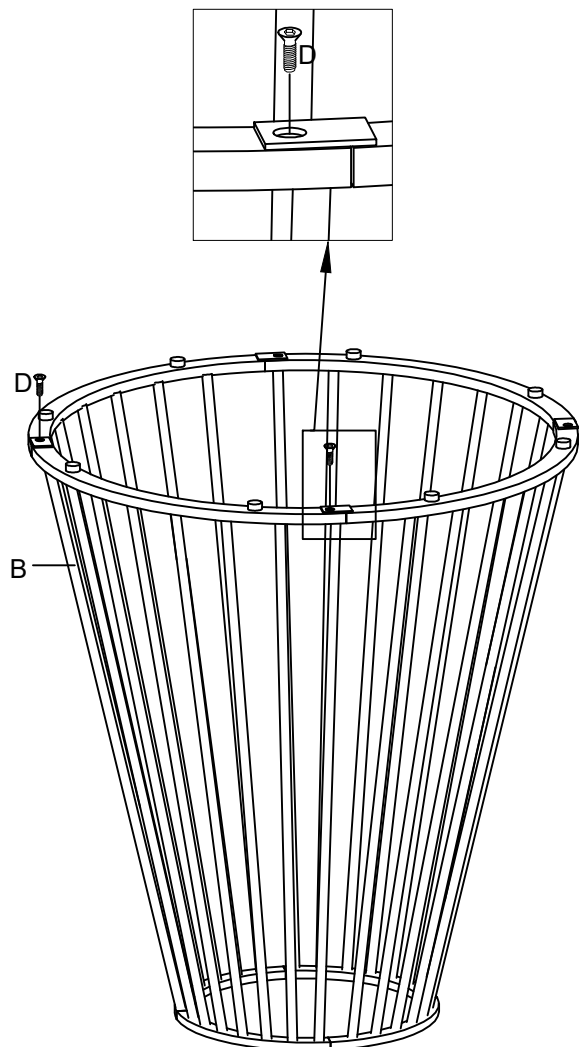

- a) Fit the last piece of Leg (B).
- b) Use Screw (D) to fasten the last leg. Do not tighten the screw completely at this time.

ASSEMBLY INSTRUCTIONS

DINING TABLE

STEP 3

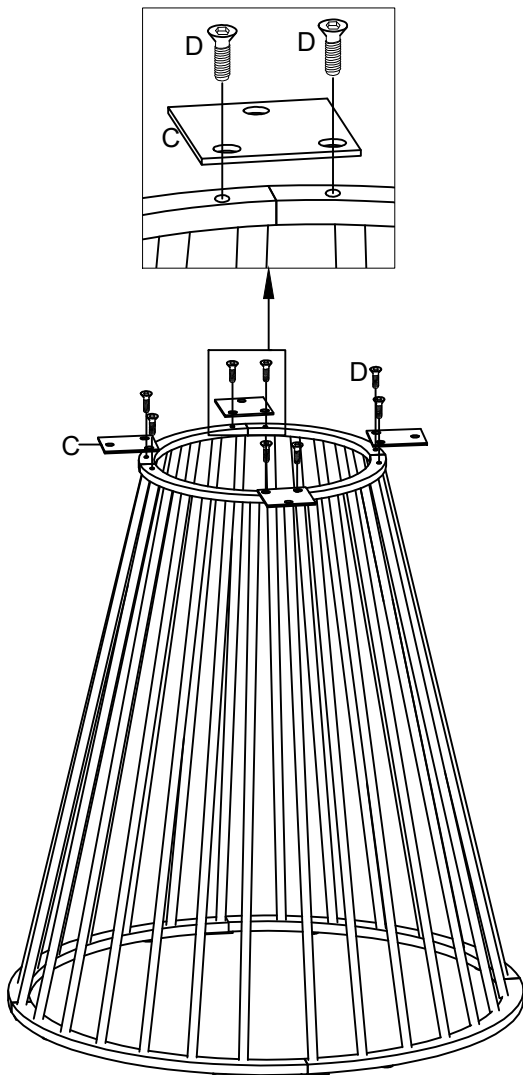

- a) Place the leg assembly from STEP 2 as shown.
- b) Use Brace Plate (C) to connect the legs and use Screw (D) to fasten (C).
- c) Tighten all of the Screw (D) on the leg assembly completely at this time.

STEP 4

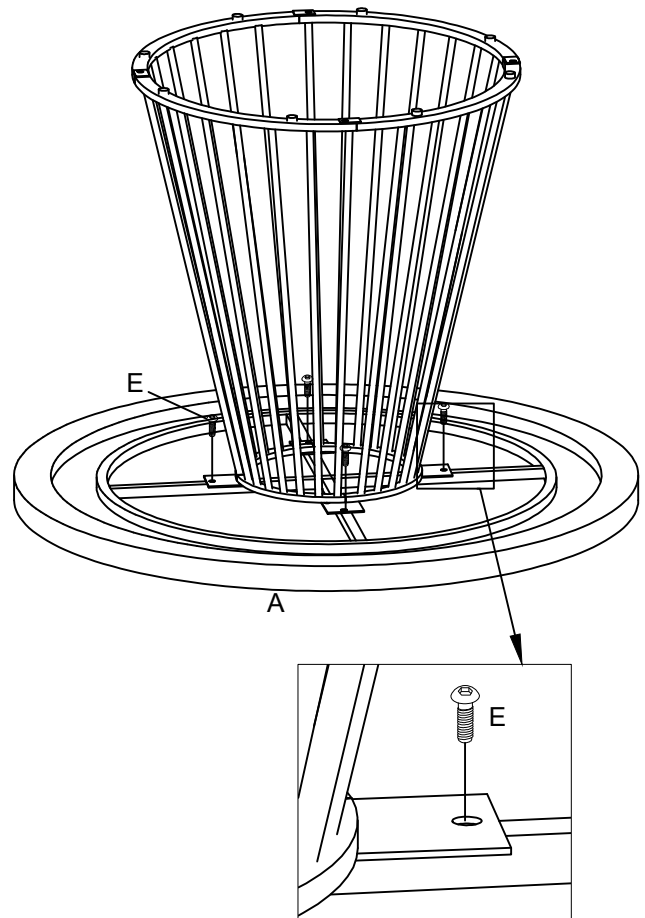

- a) Lay Table Top (A) bottom-side up as shown on a material that does not scratch or damage the part.
- b) Check that all of the Screw (D) on the leg are tightened completely.
- c) Align the screw holes on the Brace Plate to the screw holes on the cross-rail of the (A).
- d) Use Screw (E) to fasten the Brace Plate to the cross-rail. Do not tighten Screw (E) completely until all 4 screws are in place.

Set the table right-side up. The assembly of the table is complete.