

3-PIECE WICKER BISTRO SET

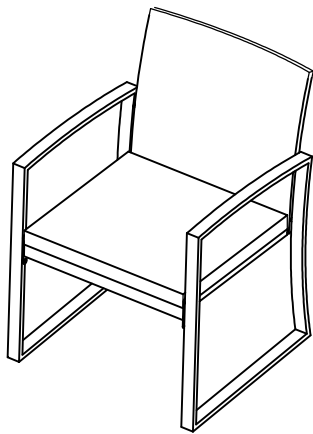

x 2

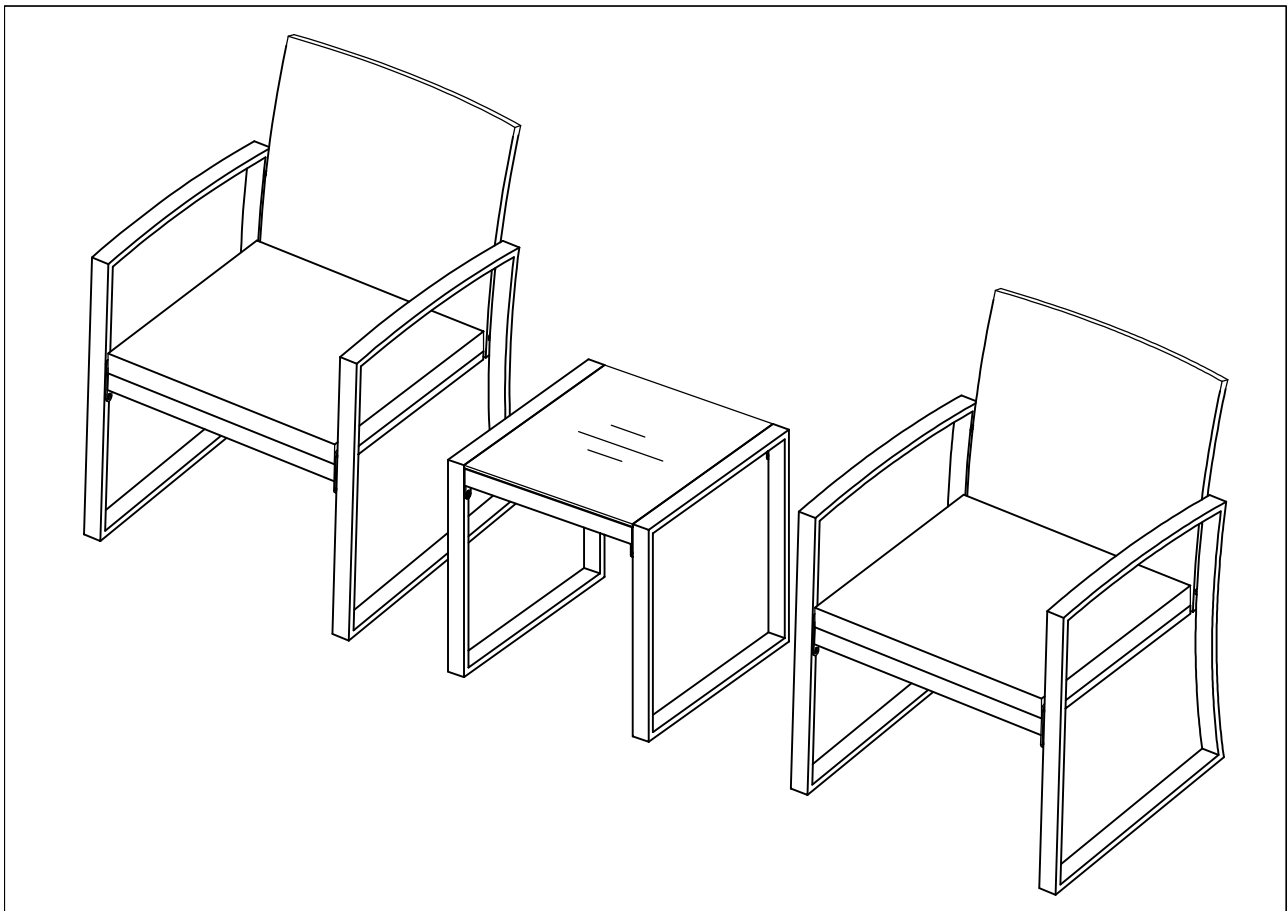
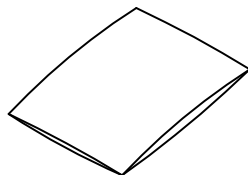
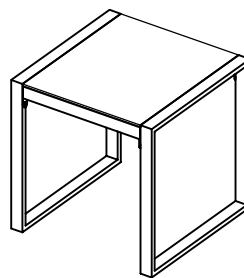

Assembly
bag

Chair

(DO THIS TWO TIMES)

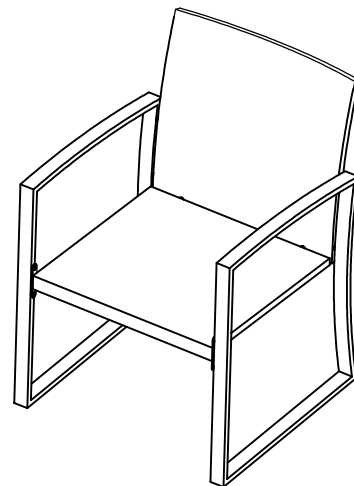

A		Right Arm Rest	1
B		Left Arm Rest	1
C		Seat Base	1
D		Seat Back	1
E		M6x35 Socket Head Cap Screw	6
F		M6x20 Socket Head Cap Screw	4
G		Flat Washer	10
H		4-mm Allen Key	1
J		Riser 6	4

1

Secure the arm rests (A & B) to the seat back (D) using a M6 x 35 socket head cap screws (E) with a washer (G), Do this in four places.

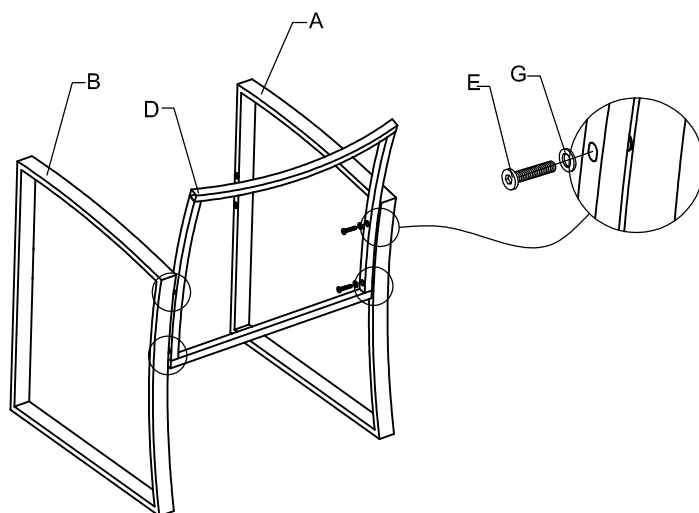





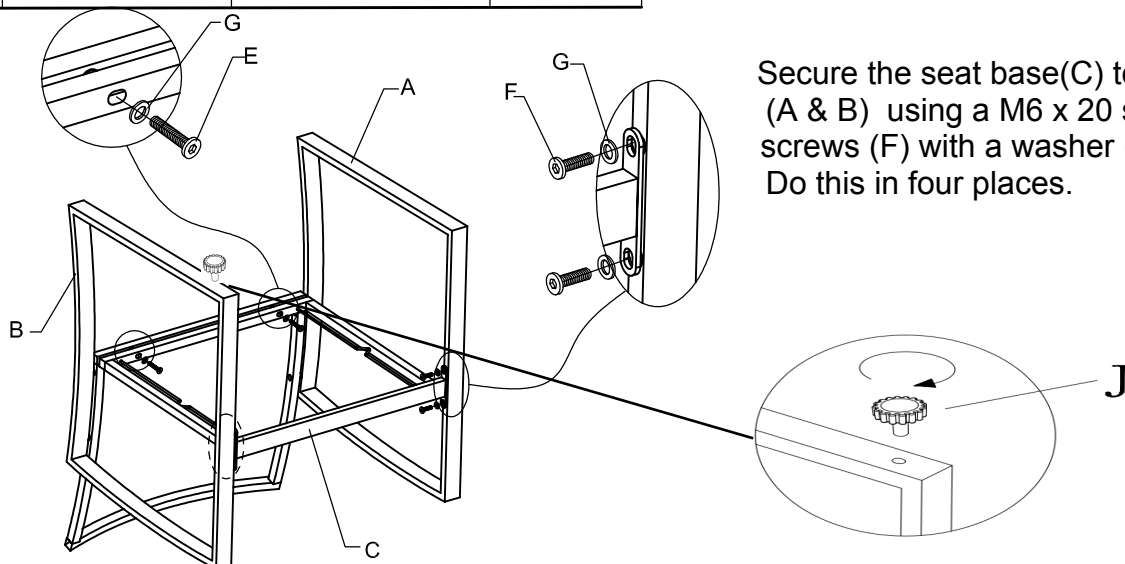

2

Attach the seat base (C) and the seat back (D) using a M6 x 35 socket head cap screw (E) with a flat washer (G). Do this in two places.

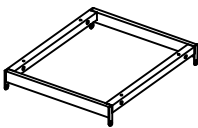
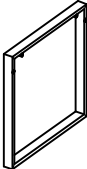
Secure the seat base (C) to the arm rests (A & B) using a M6 x 20 socket head cap screws (F) with a washer (G), Do this in four places.

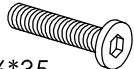
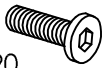

Coffee Table

A		Table Top	1
B		Legs	2
C		Glass Top	1
D	 M6*35	M6x35 Socket Head Cap Screw	4
E	 M6*20	M6x20 Socket Head Cap Screw	4
F		Flat Washer	8
G		4-mm Allen Key	1
H		Riser 6	4

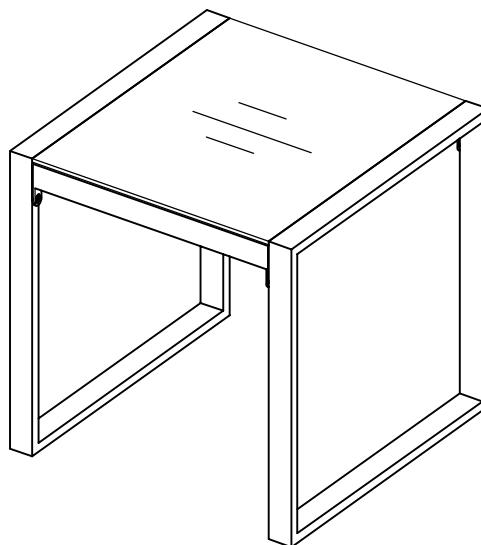

1

Attach the table top (A) and the legs (B) using a M6 x 35 socket head cap screw (D) and M6 x 20 socket head cap screw (E) with a flat washer (F). Do this in four places.

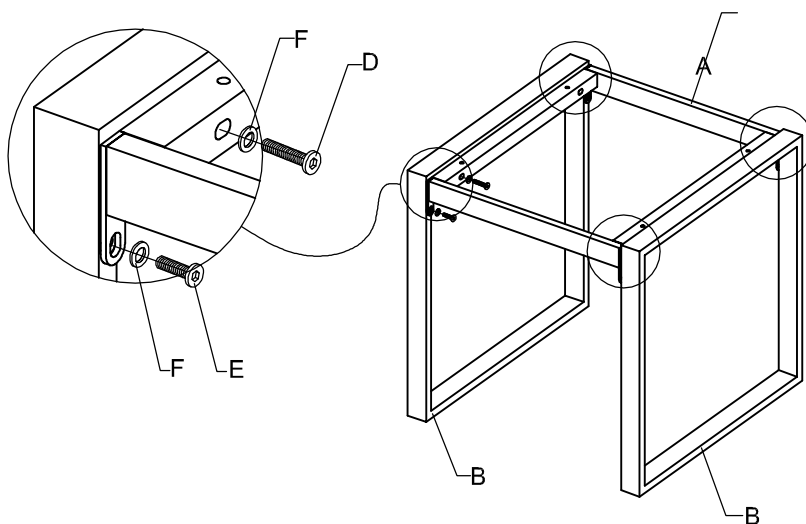

2

Flip the assembly back then place the glass top (C) on it.

