











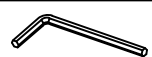

# ASSEMBLY INSTRUCTIONS

LIST OF HARDWARE			
No.	Hardware		Qty.
1	Long Bolt 80mm		8.pcs
2	Bolt 80mm		8.pcs
3	Short Bolt 25mm		8.pcs
4	Wood Dowel 30x10mm		6.pcs
5	Wood Dowel 40x10mm		4.pcs
6	Screw 30mm		20.pcs
7	Allen Key		1.pcs
8	Barrel Nut		8.pcs

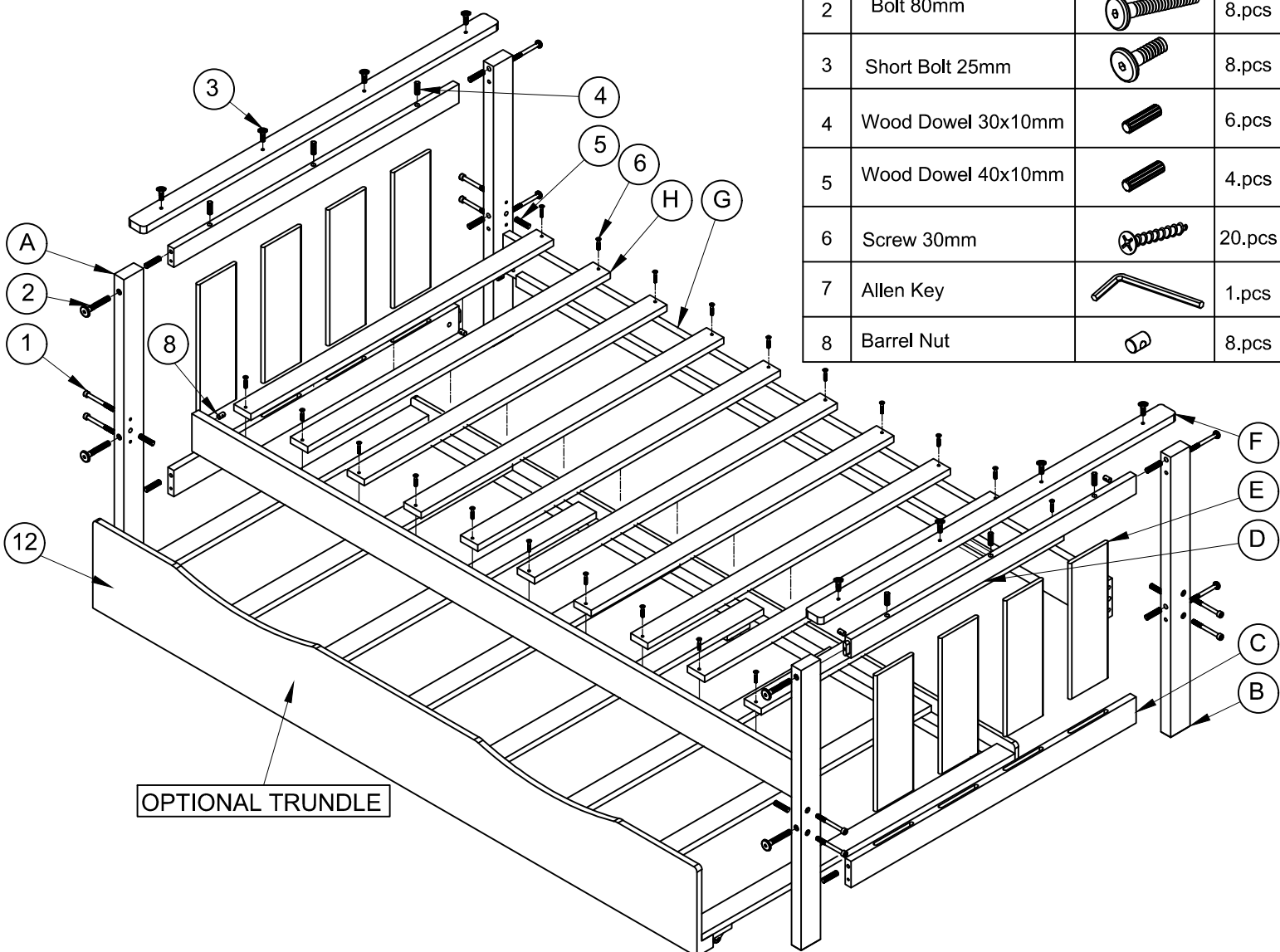
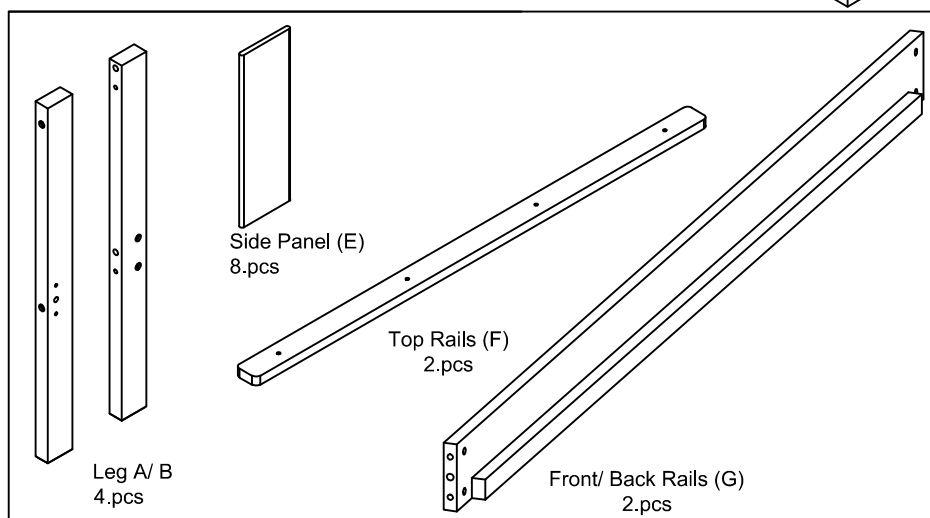

OPTIONAL TRUNDLE



No.	Hardware		Qty.
6	Screw 30mm		16.pcs
9	Screw 15mm		20.pcs
10	Wheel caster		6.pcs
11	Metal L		2.pcs

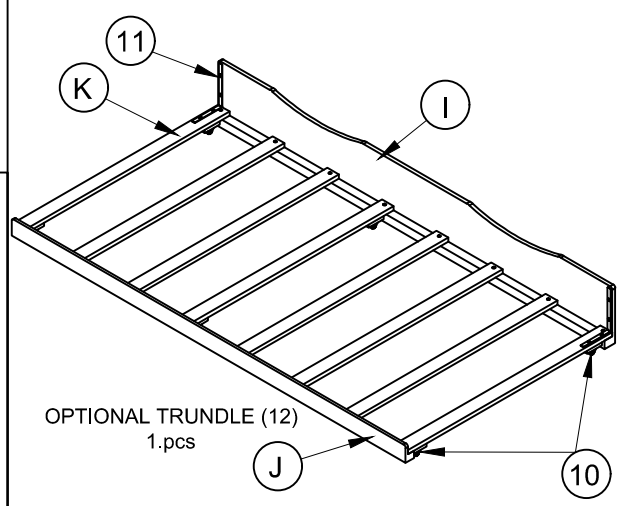
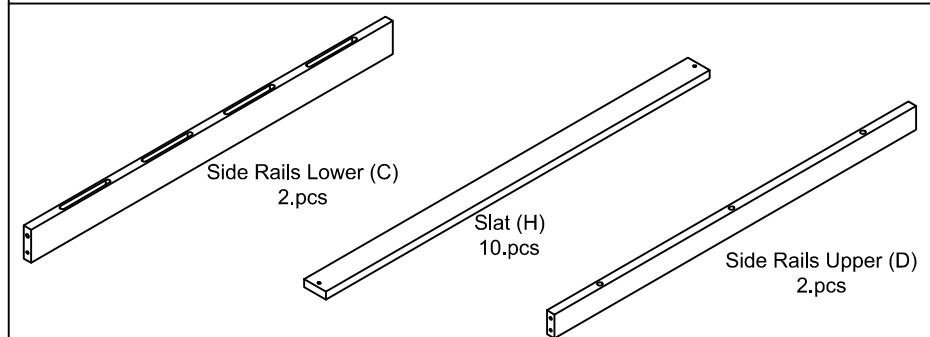



**STEP 1**

**Assembly Head board and Foot board**

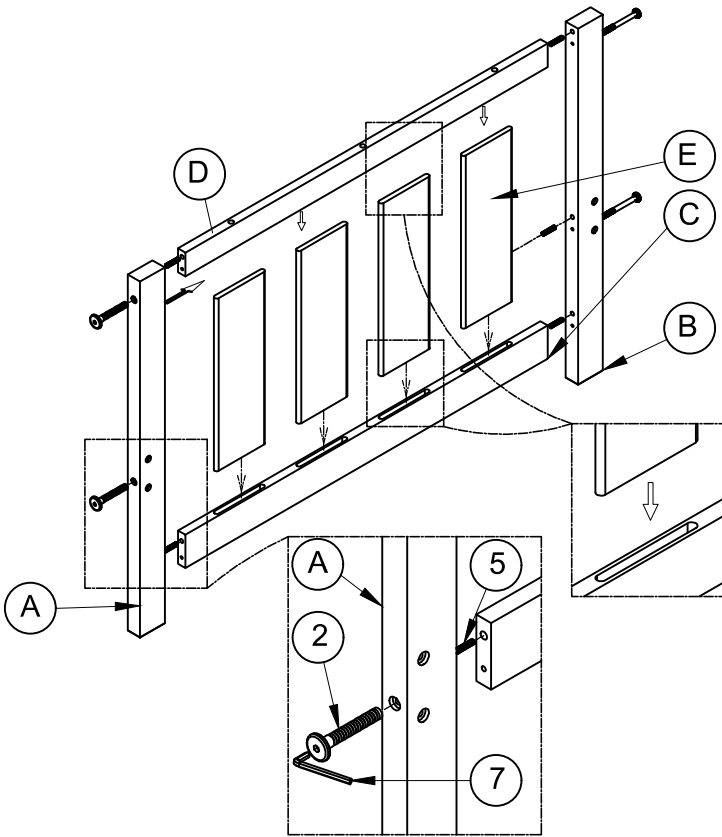
Insert wood dowels (5) into hole from outside.  
Remember to insert wood dowels also for alignment & strength.



Attach Leg (A) (B) to the Side Rails (C), by using long Bolt (2) and attach Side panel (E) to the Side Rails (C) (D), Then tighten with allen key (7).

LIST OF HARDWARE			
No.	Hardware		Qty.
2	Bolt 80mm		8.pcs
5	Wood Dowel 40x10mm		8.pcs
7	Allen Key		1.pcs

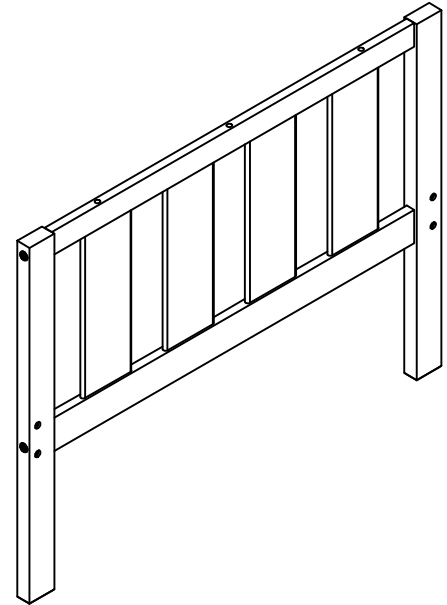

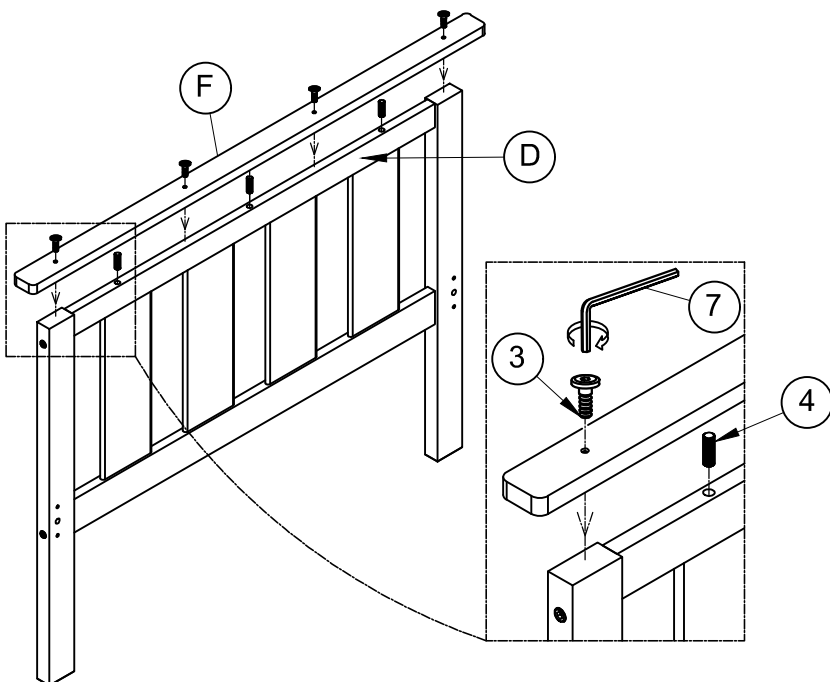

**STEP 2**

Insert wood dowels (4) into hole from outside.  
Remember to insert wood dowels also for alignment & strength.



Attach Top Rails (F) to the Side Rails (D), by using Short Bolt (3) Then tighten with allen key (7).

LIST OF HARDWARE			
No.	Hardware		Qty.
3	Short Bolt 25mm		8.pcs
4	Wood Dowel 30x10mm		6.pcs

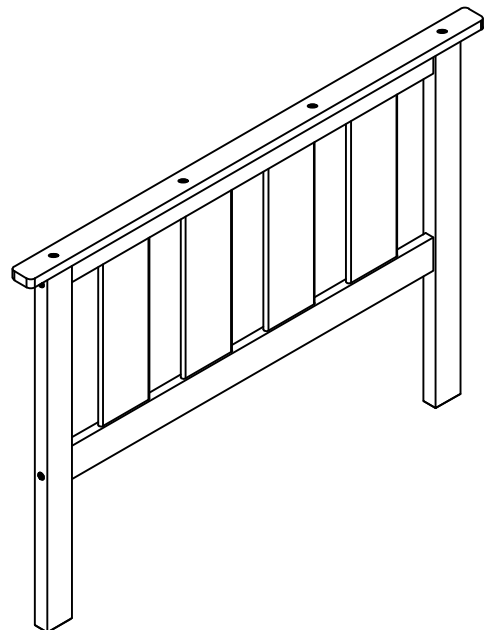



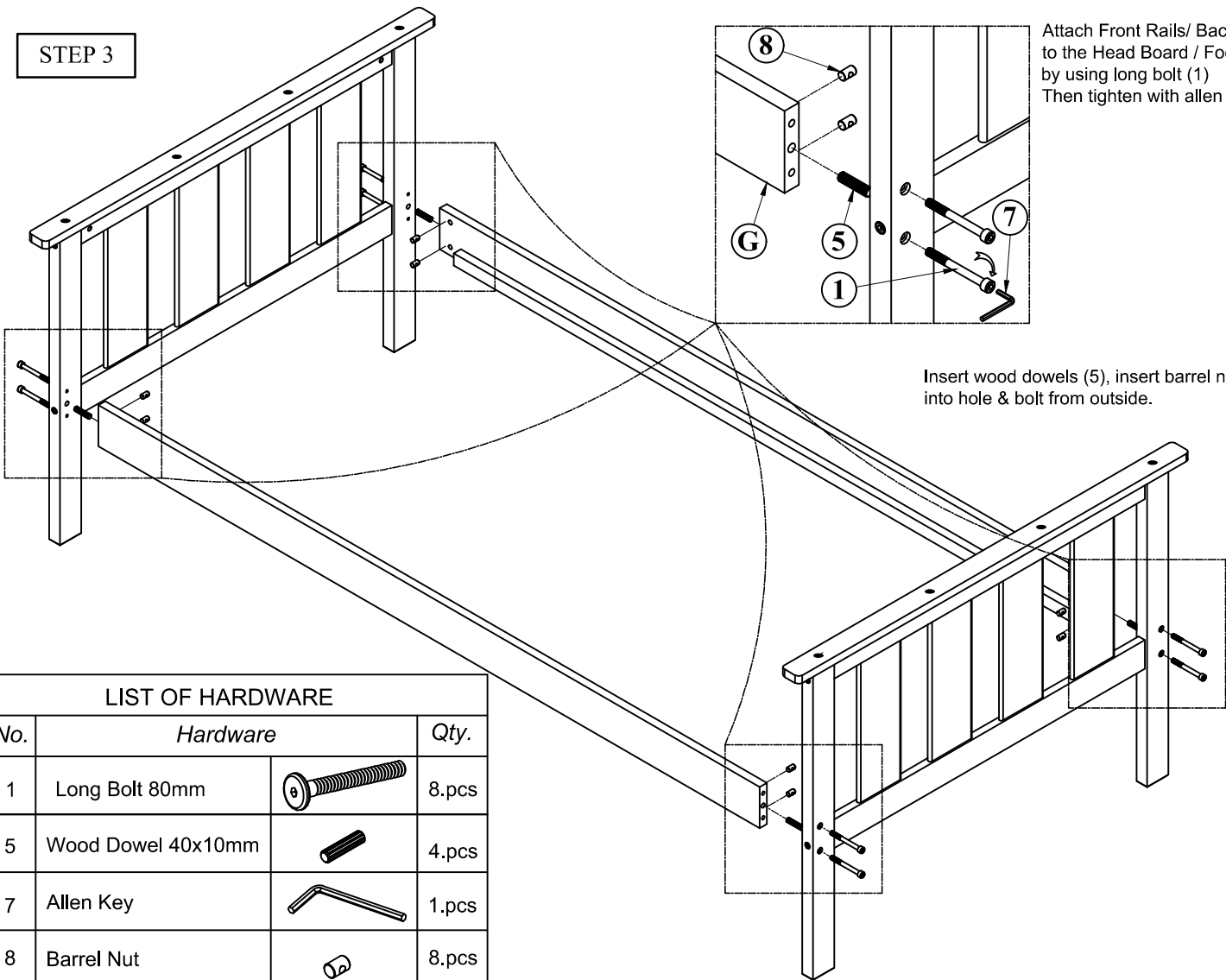

**STEP 3**

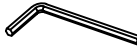

Attach Front Rails/ Back Rails (G) to the Head Board / Foot Board, by using long bolt (1) Then tighten with allen key (7).

Insert wood dowels (5), insert barrel nut (8) into hole & bolt from outside.

LIST OF HARDWARE			
No.	Hardware		Qty.
1	Long Bolt 80mm		8.pcs
5	Wood Dowel 40x10mm		4.pcs
7	Allen Key		1.pcs
8	Barrel Nut		8.pcs

**STEP 4**

Attach Slat (G) to Front/ Back Side Rails by using Screw (6). Then tighten with screwdrivers.

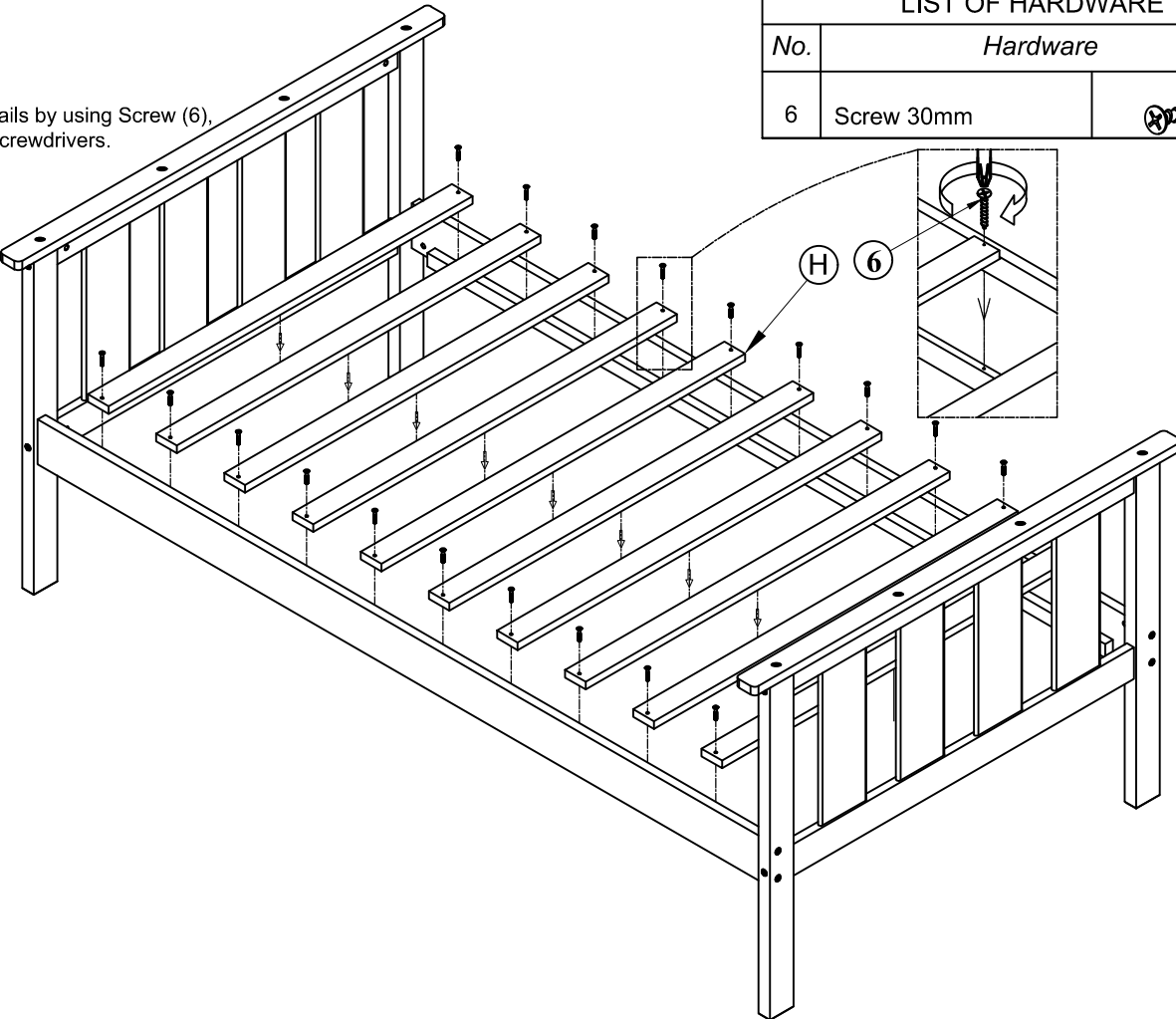

LIST OF HARDWARE			
No.	Hardware		Qty.
6	Screw 30mm		20.pcs

**STEP 5**

LIST OF HARDWARE		
No.	Hardware	Qty.
6	Screw 30mm	16.pcs

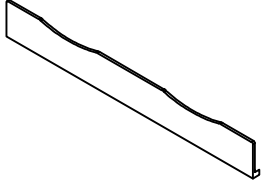
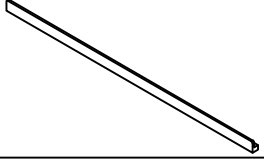
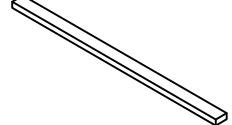
No.	PART LIST		Qty.
I	Front Panel		1.pcs
J	Back Panel		1.pcs
K	Rails		8.pcs

**Assembly Optional Trundle**

Attach Rails (K) to the Front panel (I) and Back Panel (J) by using Screw (6)  
Then tighten with screwdrivers.

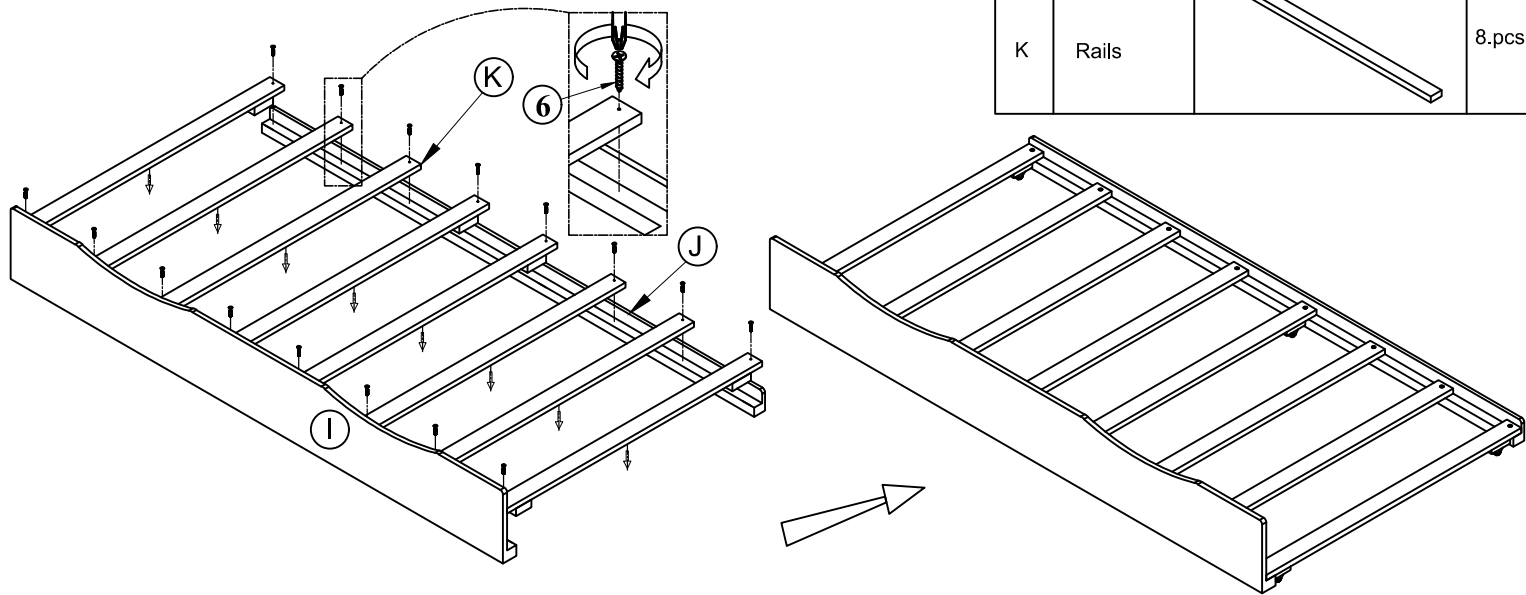

**STEP 6**

LIST OF HARDWARE		
No.	Hardware	Qty.
9	Screw 15mm	20.pcs
10	Wheel caster	6.pcs
11	Metal "L"	2.pcs

NOTE: Two the wheels caster in this position can be added or non.

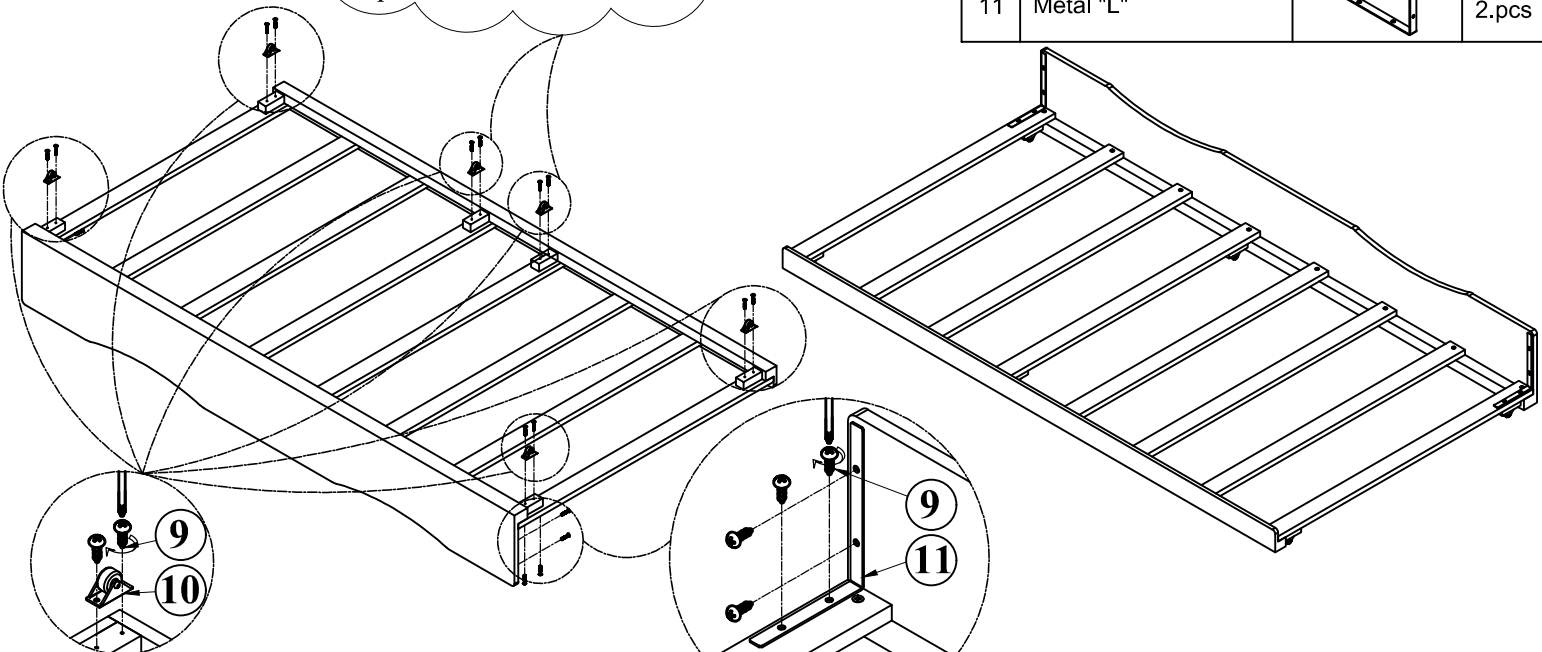

Assembly Wheel Caster to the Optional Trundle (12)  
by using Screw (9)  
Then tighten with screwdrivers.

Attach Metal "L" to the Front panel (I) and Rails (M),  
by using Screw (9)  
Then tighten with screwdrivers.