

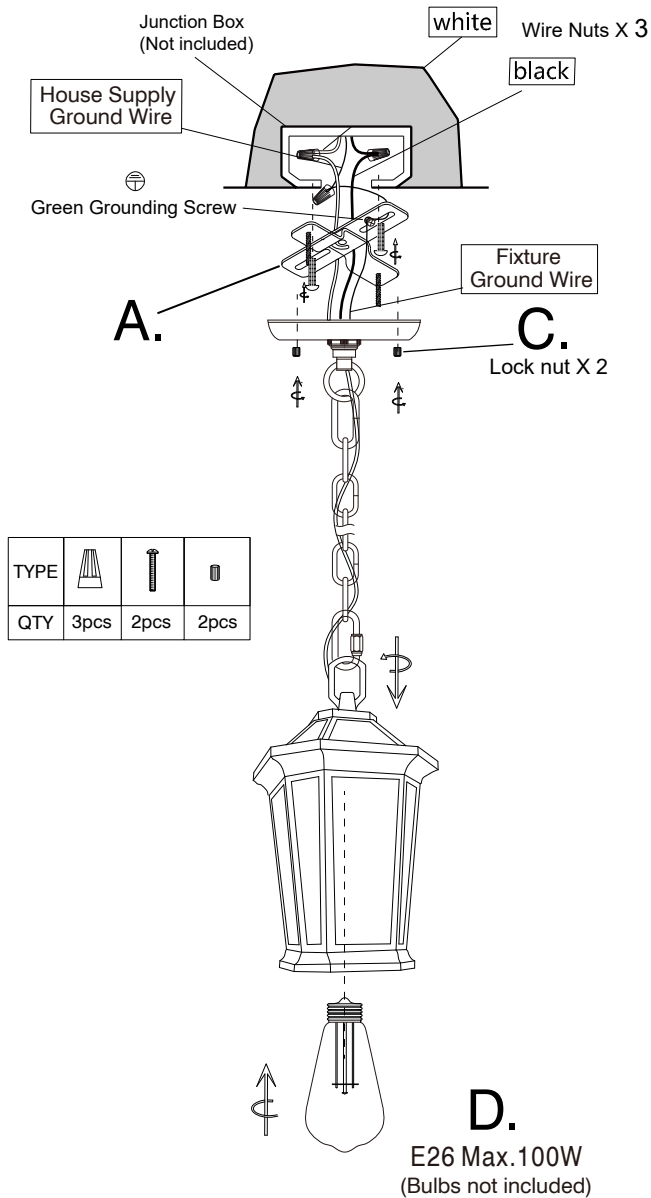

INSTALLATION INSTRUCTIONS FOR OUTDOOR PENDENT LIGHT

Model:83091



Before starting the installation, disconnect the Power by Turning Off the Circuit Breaker. Turning the Power Off using the LightSwitch is not sufficient to prevent electrical shock. All electrical connections and installation must be following local codes, ordinances, and/or National Electric Code and Must Be Done by an Electrician Only.

1. Fasten Cross Bar onto Outlet Box using 2 Outlet Box Screws. (Make sure the thread of the mounting screws is facing outside when the Cross Bar is attached to the Outlet Box).(A)
2. Using two pliers, twist opens the links at two ends of the Chain. Hook one connection to the Loop of the Canopy, and close the link. Hook the other link to the Loop of the fixture, and close the link. Wave the fixture wires up through the chain links, the Loop, and the Canopy in the Cross Bar.(B)
3. Connect the wire with writing on it from the fixture to the black wire from the supply circuit. Connect the wire without writing (with raised ribs)from the institution to the white wire from the supply circuit. Cover the connections using the wire connectors provided with the fixture. Connect the ground wire from the house to the ground wire from the institution with the provided wire connectors.
4. Fasten the Canopy onto the ceiling by using the Lock Nuts provided.(C)
5. Install a light bulb. The bulb must not exceed the wattage specified on the fixture label(E26 100W Max.)(D)
6. Turn on the power.

1 YEAR LIMITED WARRANTY*

This Light Fixture is warranted against defects in material and quality for 1 year from the purchase date.

This warranty does not cover acts of nature such as lighting damage or corrosion and discoloration of components. Nor does it cover damages caused through abuse, improper installation, surges in electric current, or acts of third parties. This warranty does not cover the costs of removing and resealing the lighting fixture.

If this product falls for any reason covered by this warranty, feel free to contact us.

24hr SERVICE EVERYDAY

Any question? please kindly contact us through AMAZON,We will help you with a satisfactory solution in 24 hours.

