

Assembly Instructions

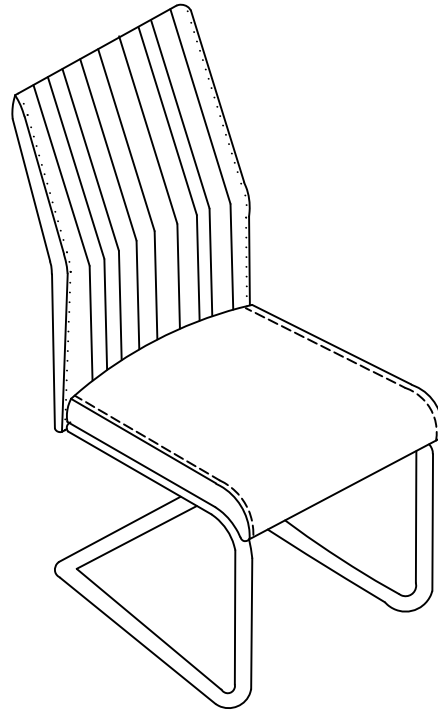

Please check you have all the parts listed below

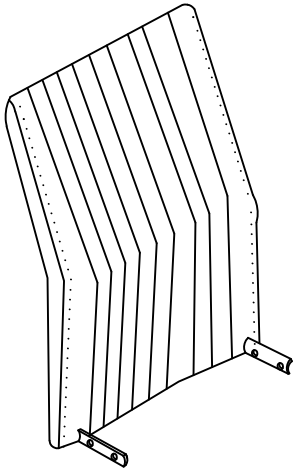

1 Back rest x 1

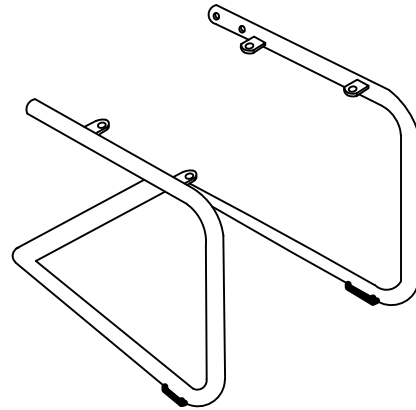



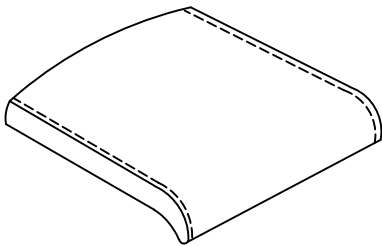



2 Leg frame x 1

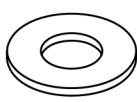

3 Seat pad x 1

Please check you have all the fittings listed below

Note: The quantities below are the correct amount to complete the assembly. In some cases more fittings may be supplied than are required.

<p>A</p>  <p>M8x20mm Allen Screw X4</p>	<p>B</p>  <p>M8x22mm Metal Washer X4</p>	<p>C</p>  <p>M6x20mm Allen Screw X4</p>	<p>D</p>  <p>M6x16mm Metal Washer X4</p>
<p>E</p>  <p>M6 mm Allen Key X1</p>	<p>F</p>  <p>M4 mm Allen Key X1</p>	<p>G</p>  <p>M8x12mm Spring Washer X4</p>	<p>H</p>  <p>M6x10mm Spring Washer X4</p>

Ruler - Use this ruler to help correctly identify the screws

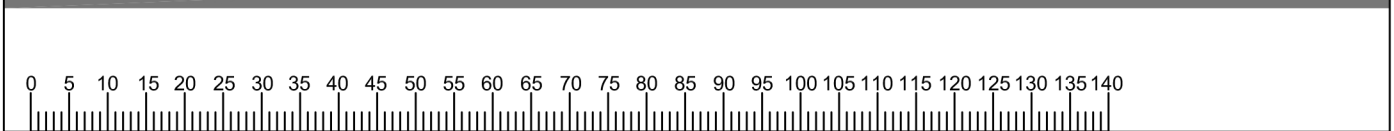

Assembly Instructions

Step 1

Place the leg frame on the floor

2.

Insert backrest **1** into the leg frame **2**

Using fixings **A**, **B** & **G** tighten the backrest onto the legs.

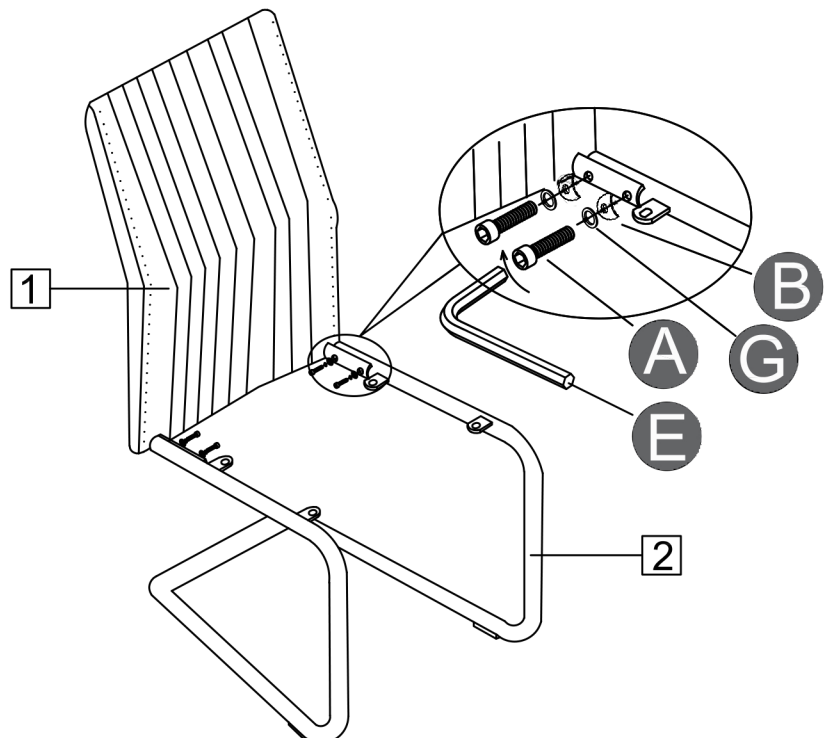

Step 2

Attaching Seat Pad

Place seat pad **3** upside down onto a clear flat surface.

Carefully align the chair frame onto the seat pad **3** and secure using fixings **C** & **D** & **H**

Repeat assembly on all chairs.

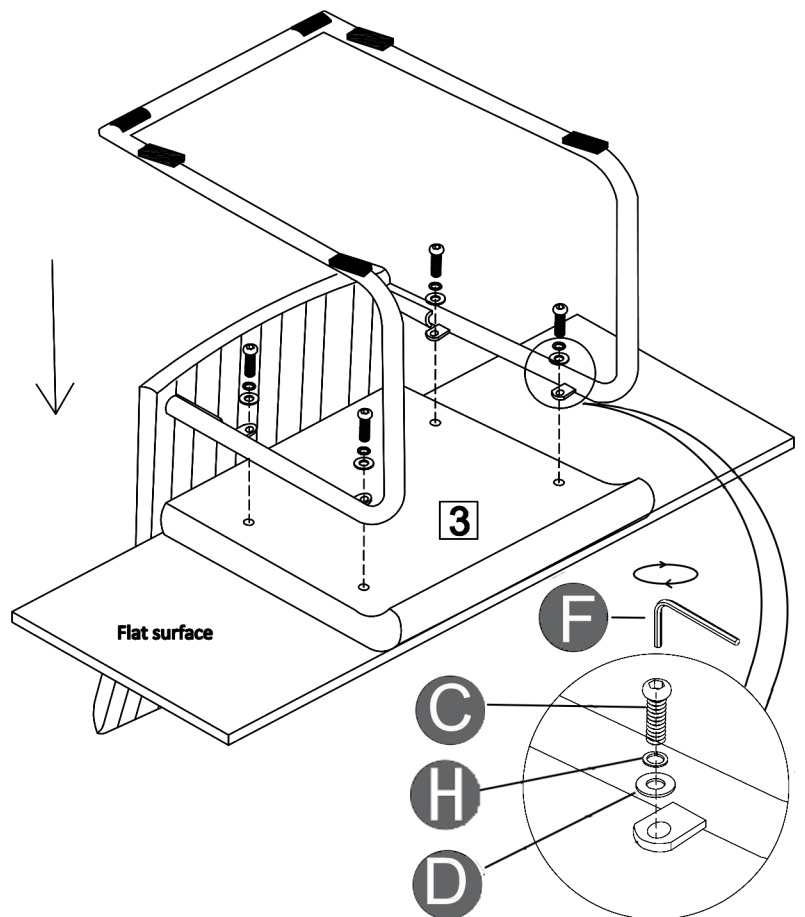

Step 3

Assembly completion

Sit on the chair and fully tighten all bolts.

