





ASSEMBLY INSTRUCTIONS & PARTS IDENTIFICATION

SOFA TABLE TWIN CITIES COLLECTION

Thank you for purchasing this quality product. Be sure to check all packing material carefully for small parts that may have come loose inside the carton during shipment.

Hardware kit			
No		Description	Q'Ty
A		Lock Washer Ø8	16 pcs
B		Flat Washer Ø8	16 pcs
C		Bolt Ø6 x 70mm	16 pcs
D		Allen Key	1 pc

Anti-Tip Hardware		
No	Description	Qty
E	Plastic bracket	2 pcs
F	Plastic strap	1 pc
G	Short screw	2 pcs
K	Long screw	2 pcs

Key Parts			
No	Code	Description	Q'Ty
1	A	Table Leg	4 pcs
2	B	Shelf Upper	1 pc
3	C	Shelf Lower	1 pc
4	D	Drawer Right Side facing	1 pc
5	E	Drawer Left Side facing	1 pc
6	F	Drawer Middle	1 pc
7	G	Pull W/Screw	3 pcs
8	H	Drawer Stop	3 pcs
9	I	Drawer glide	6 pcs
10	J	Floor glide	4 pcs
11	K	Drawer Box	1 pc

STEP 1

- Take Drawer out unit making sure that Drawer Stop (8) is in open position first.

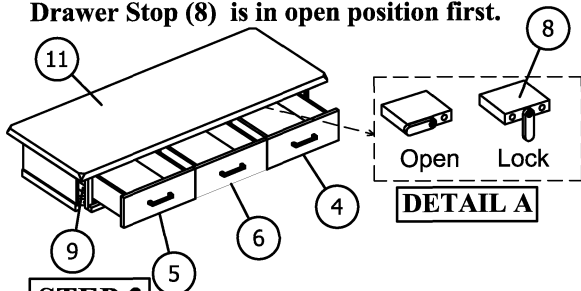

STEP 2

- Carefully lay Table Top upside down on a smooth flat surface
- Attach each Leg to each corner of the Table Top as shown in illustration. Insert a Flat Washer(B) and Lock Washer(A) with Bolt(C) by turning clockwise using provided Allen Key but not fully tighten. (See Detail B)

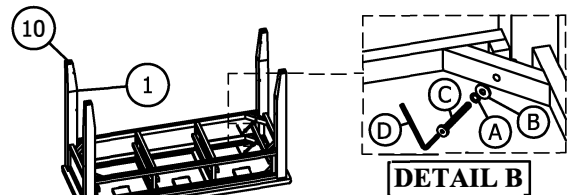

STEP 3

- Attach the Upper Shelf to each leg as shown in illustration. Insert a Flat Washer(B) and Lock Washer(A) with Bolt (C) by turning clockwise using provided Allen Key but not fully tighten. (See Detail C)

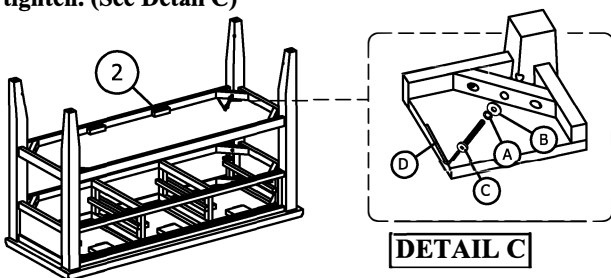

STEP 4

- Attach the Lower Shelf to each Leg as shown in illustration. Insert a Flat Washer(B) and Lock Washer (A) with Bolt (C) by turning clockwise using provided Allen Key and fully tighten all bolts at this time. (See Detail C)

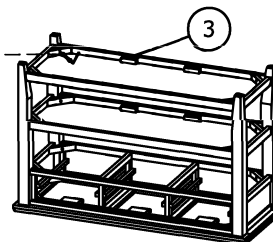

STEP 5

- Insert Drawer into unit making sure that Drawer Stop is in open position first.
- After drawer has been inserted reposition Drawer stop so that it is in the locked position. (See Detail A)

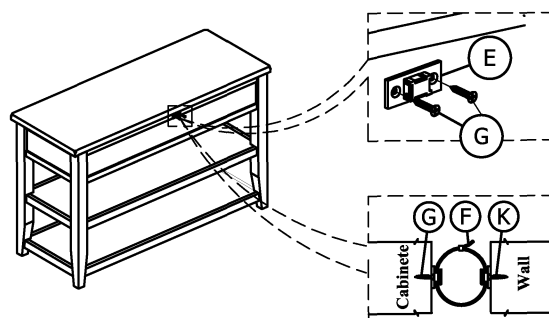
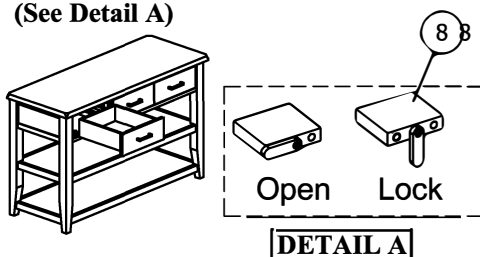

PLEASE NOTE:

To avoid the possibility of the furniture tipping and injury, the anti-tip hardware must be installed.