

Assembly Instructions



Assembly Instructions

ASSEMBLY REQUIREMENT

1 PERSON ASSEMBLY | 30 MINUTES ASSEMBLY TIME (APPROXIMATE)
TOOLS REQUIRED: ALLEN WRENCHES (PROVIDED)

ASSEMBLY REQUIREMENT

1. Remove all packaging materials, staples and packing straps from the carton.
2. Refer to Parts Checklist and ensure they are complete before you start assembling.

TIPS FOR ASSEMBLY

1. Allow ample room for assembly and in close proximity to where product will be placed.
2. Assemble the product on a surface that does not scratch or damage the exterior and finish of the furniture.
3. During assembly, do not over-tighten any fittings as this may cause damage.
4. Do not use power tools to assemble this product.
5. Do not sit or stand on the partially assembled product, only use the product for which it is intended.

CARE AND USE

- Recommended for indoor and residential use only.
- Wipe with a soft, dry cloth. Do not use harsh abrasives or household cleaners as they may damage the finish.
- Check all the fittings periodically and re-tighten as necessary. Do not use the product if any of the parts is damaged or broken.

Office Chairs Limited Warranty

Office chairs are warranted from the date of purchase against failure due to material and workmanship as follows

1 YEAR on component parts including Control Mechanisms, gas cylinder, wood, plastic parts, base and casters.

1 YEAR on Upholstery mesh and foam against wear and deterioration.







To make a warranty claim, , provide model number, proof of purchase and description of the problem.

At it's option will:

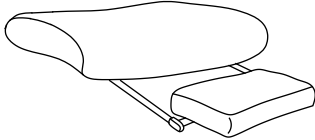
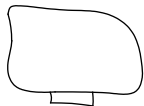
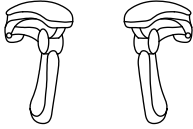
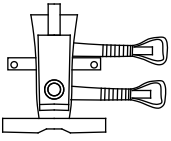
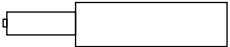
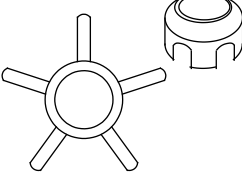
- a) Supply compatible components of current manufacture.
- b) Send a new product if necessary, customer must return the original product to the warehouse.

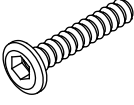
RETURN POLICY

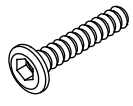
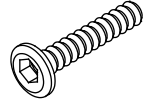
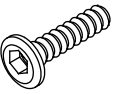
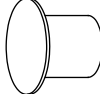
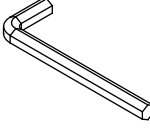
Customers can request to return the item within 30 days of receiving it.

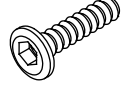
 <p>Ax1</p>	 <p>Bx1</p>	 <p>Cx1</p>	 <p>Dx1</p>	
 <p>Ex1</p>	 <p>Fx1</p>	 <p>Gx1</p>	 <p>Hx5</p>	 <p>Ix5</p>
 <p>8x25 Jx2</p>	 <p>K1x7 K2x4</p>	 <p>8x35 Lx2</p>	 <p>6x25 Mx2</p>	 <p>8x20 Nx3</p>
 <p>6x18 Ox4</p>	 <p>Px4</p>	 <p>Qx1</p>	 <p>Rx1</p>	 <p>6x18 Sx10</p>

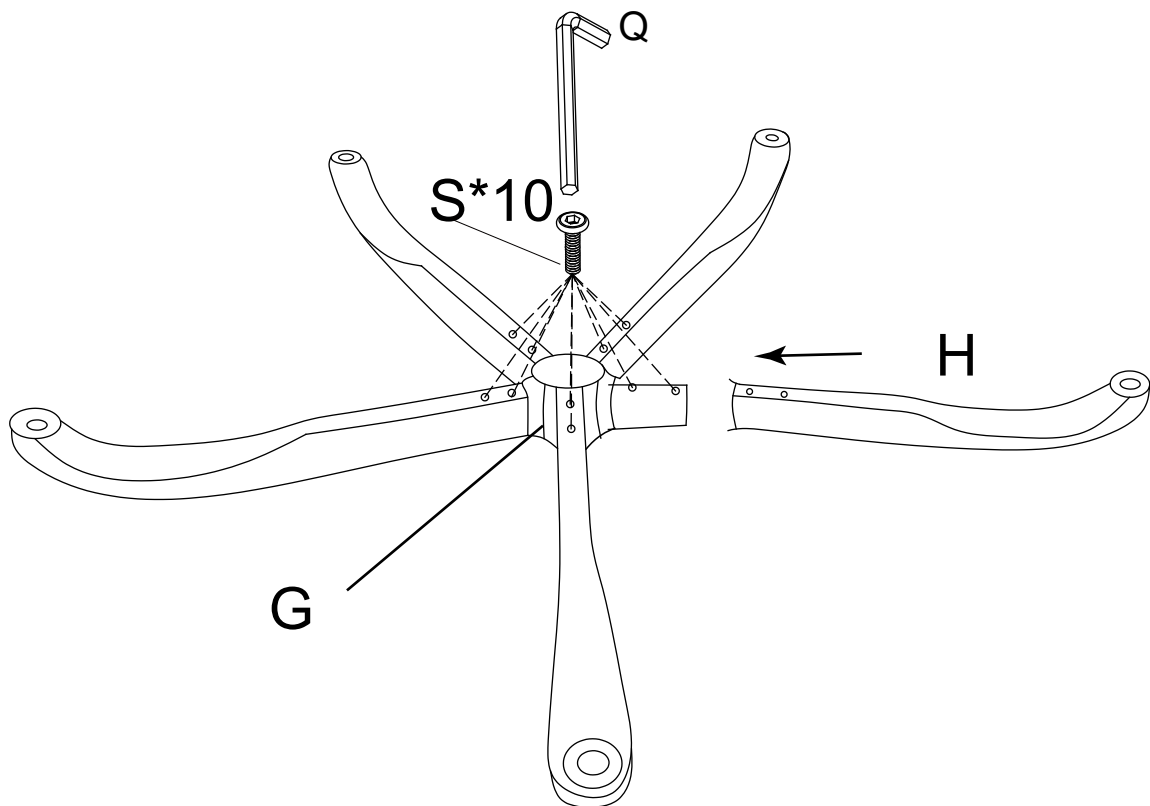

Step 1: Insert Base Legs[H] one by one to the Base Center[G]. Next, screw ten Screw[S] into the holes with the Allen Wrench[Q]to attach the base and the legs.

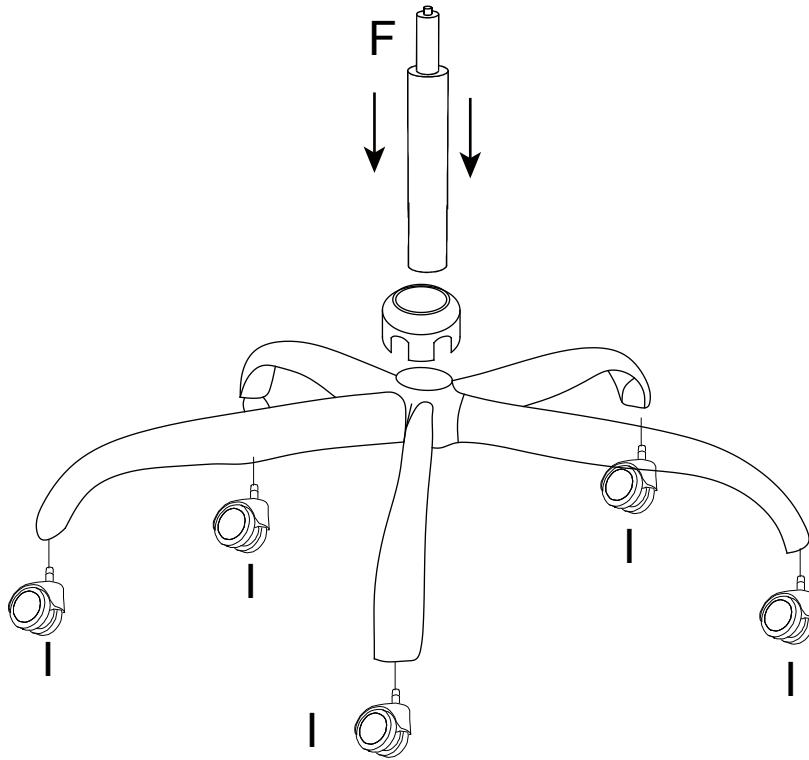

Step 2: Insert the casters [I] into the five star base. This may take significant force. Gently squeeze the base cover and place around the center of the 5 star base. Insert the gas lift into the center of the base.

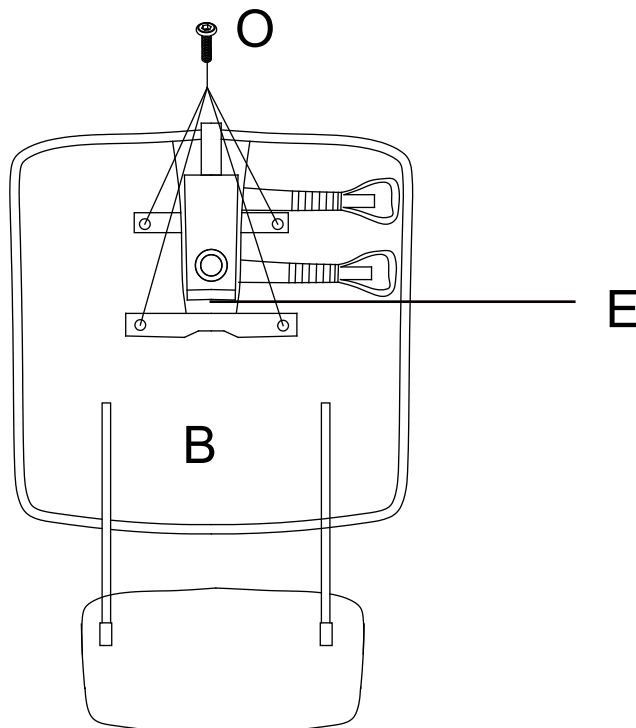

Step 3: Align the Mechanism [E] over the pre-drilled holes underneath the Seat Cushion [B], make sure the front of the mechanism is facing the front of the Seat. Attach the Mechanism to the Seat with Screws [O].

Note: Do not tighten all screws to 100%, make sure it has space to adjust in the next steps.

The backrest needs to be inserted into the tray, not attached to the outside when installed.

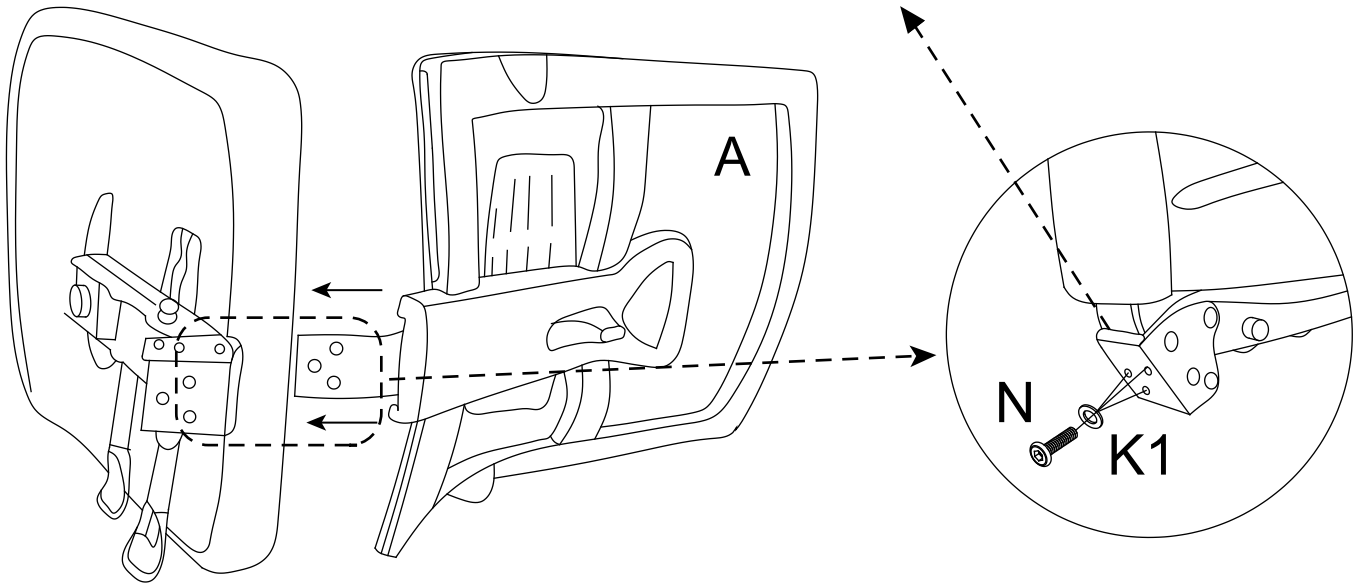

Step 4: Attach the Backrest [A] to the Seat Cushion with Washers [K1] and Screws [N].

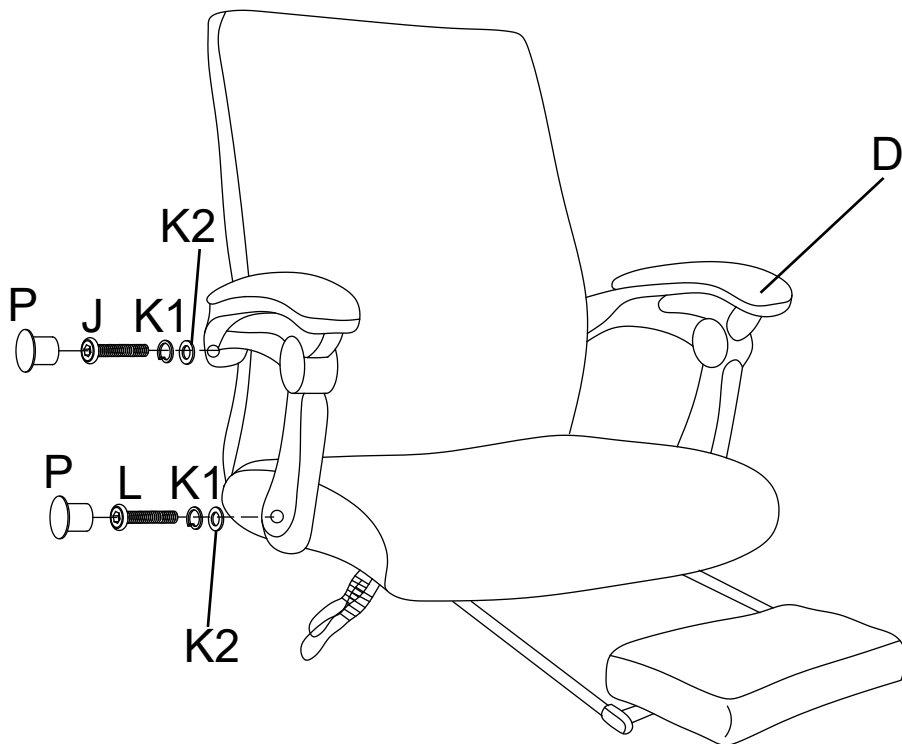

Step 5: Attach the Armrest [D] to the Seat Cushion [B] and Backrest [A] with washers [K1], [K2], Screws [J], [L] and Cover [P].

Note: Screw [J] attach the armrest to backrest; Screw [L] attach the armrest to seat cushion.

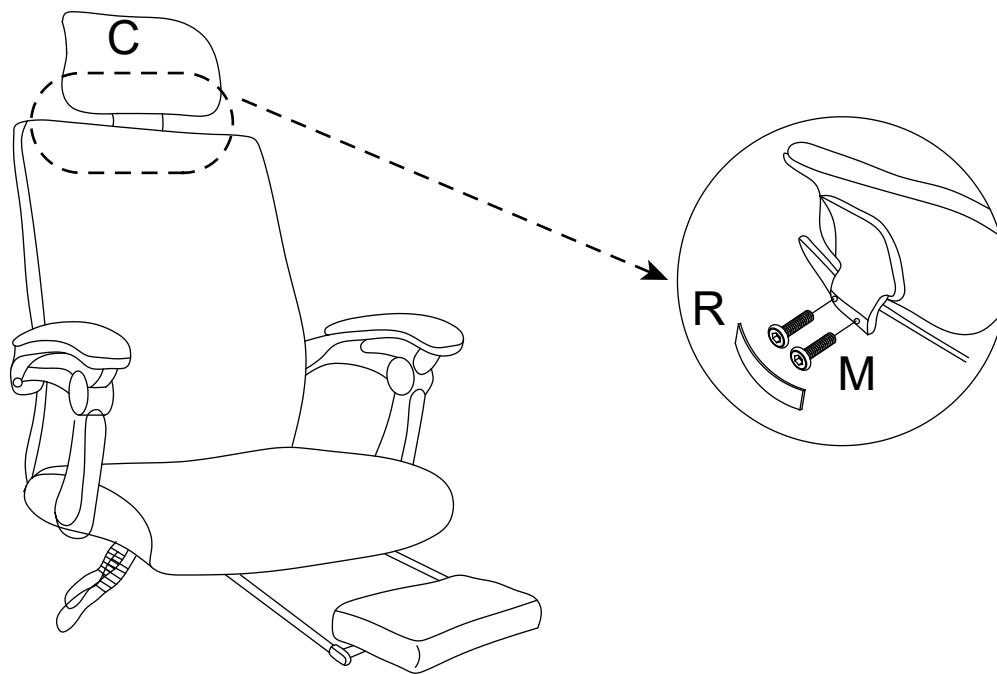

Step 6: Attach the Headrest [C] to the Backrest with Screws [M] and Cover [P].

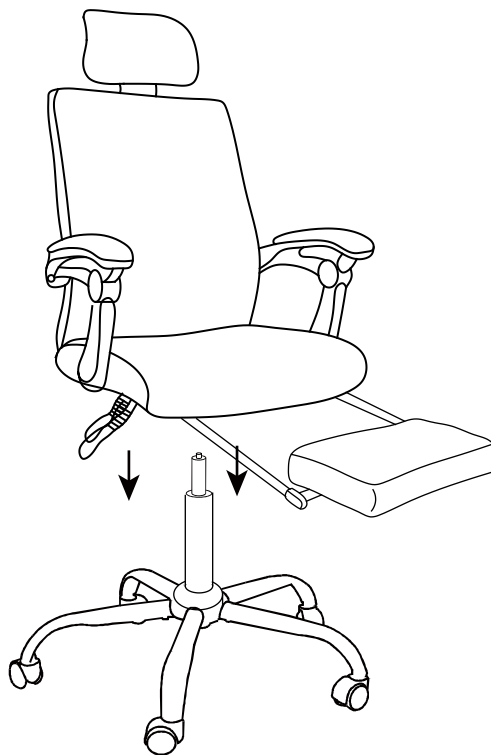

Step 7: Insert the Seat Base into the tilt mechanism.



Step 8: Enjoy your Office Chair!

Missing something?

We work very hard to ship a perfect product, but sometimes furniture or hardware go missing or get damaged in transit.

Please contact us and we'll quickly make it right.