

# Manual Recliner Chair Assembly Instruction

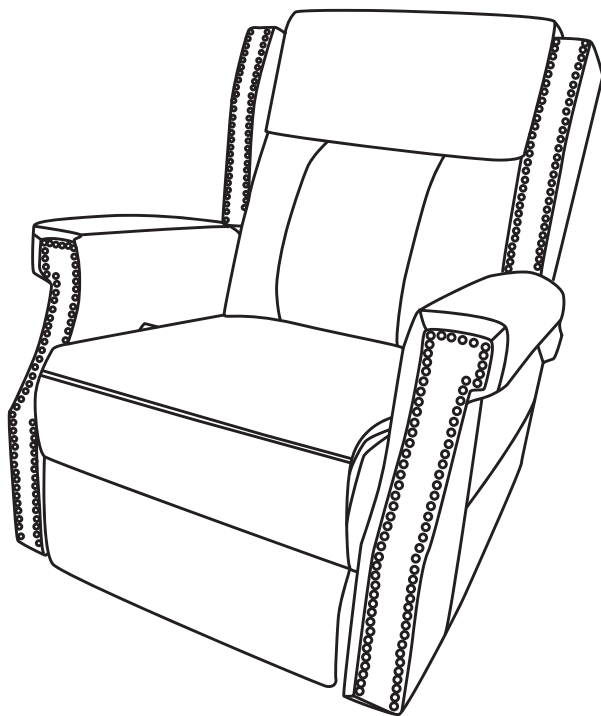

Please make sure you've got everyting lists as following before assembly.

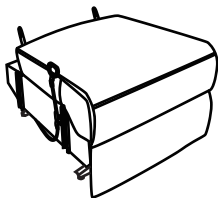

**A** Chair base

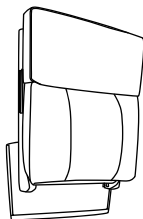

**B** Backrest

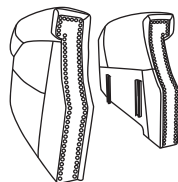

**C** Armrest x2

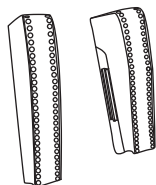

**D** Ear x2



**E** Remote control

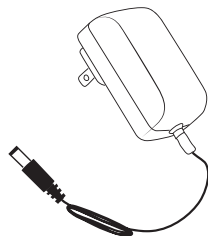

**F** Power cord

# STEP 1

Insert Armrests (C) to the chair base(A),make sure the slots on the armrests fully assembled to the bottom part.

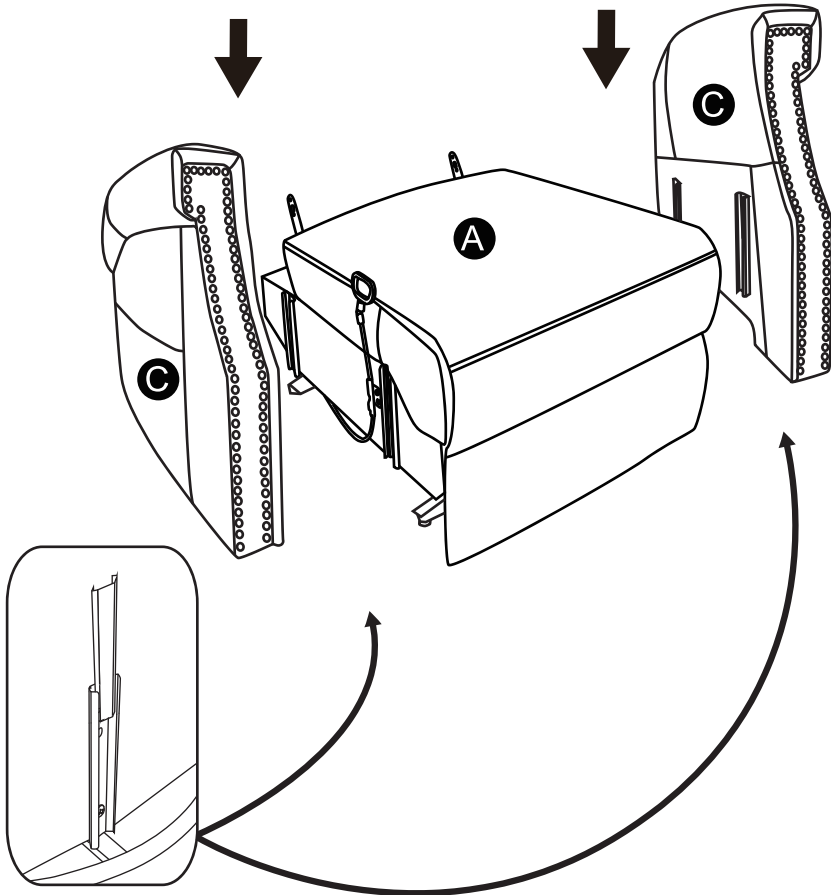

## STEP 2

Insert ears(D) to the back(B),make sure the slots on the ears fully assembled to the backrest.

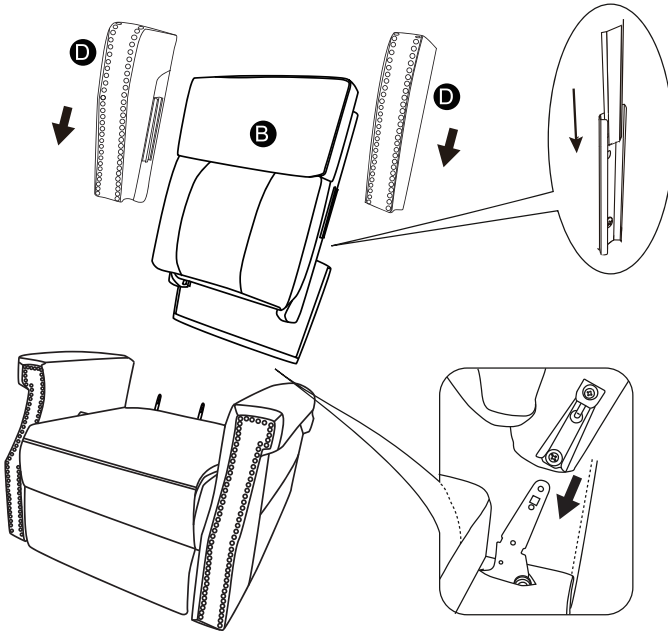

## STEP 3

Insert Chair Back(B) to the Chair Base(A),make sure the slots on the back fully assembled to the bottom part.

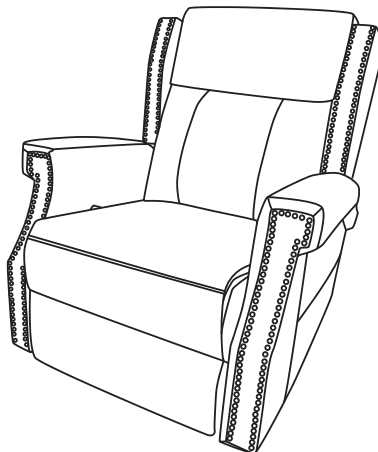

## STEP 4

No.1 and No.2 wire connect with the backrest and chair base.

No.3 wire connects with backrest and power cord(F).

No.4 wire connects with backrest and remote control(E).

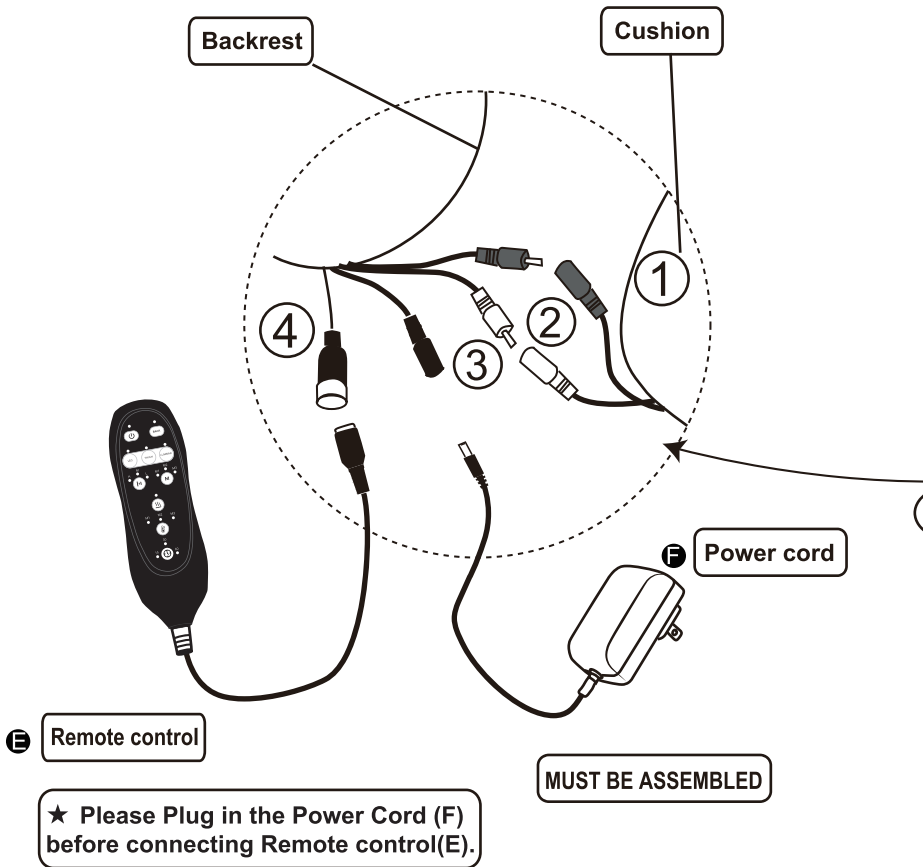

## NOTE

- 1: Two same color wires connect.
- 2: Please connect all wires BEFORE plug power cord into outlet.

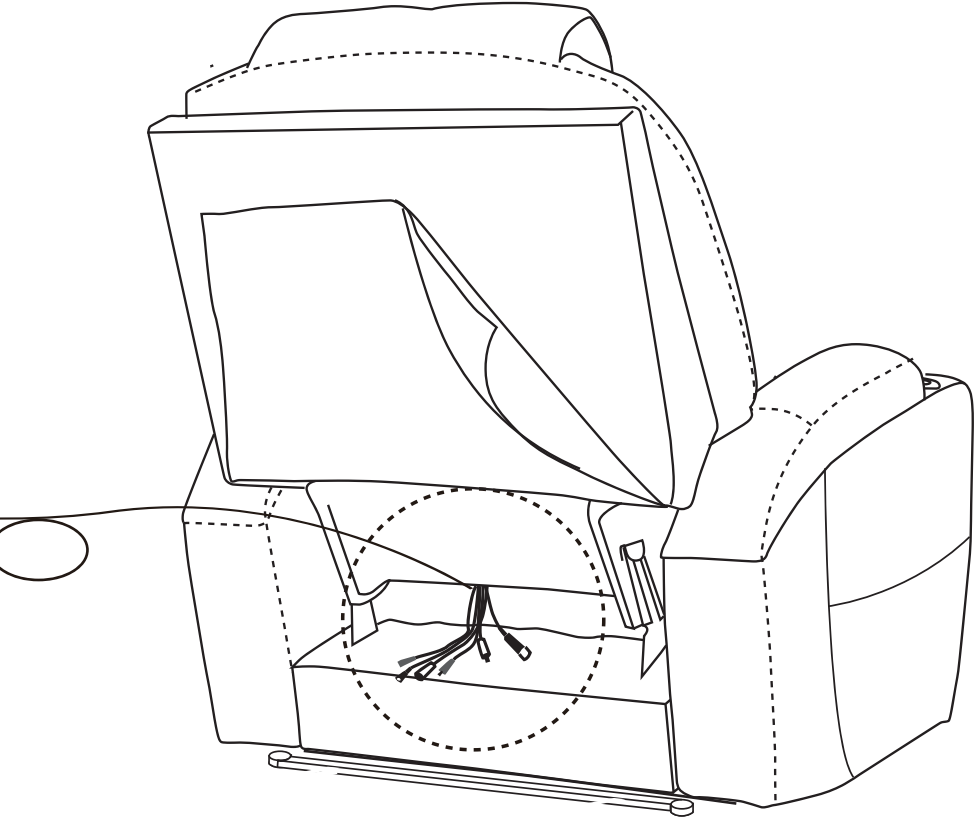

# How to recline?

1. Lift the handle on the right side up to release footrest.

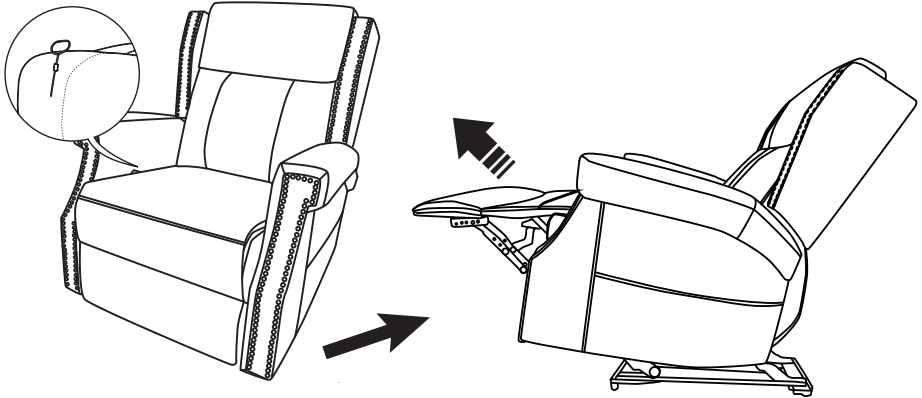

2. Sit deeper on the chair, put hands on armrests, lie down and use both hands and back strength to recline.

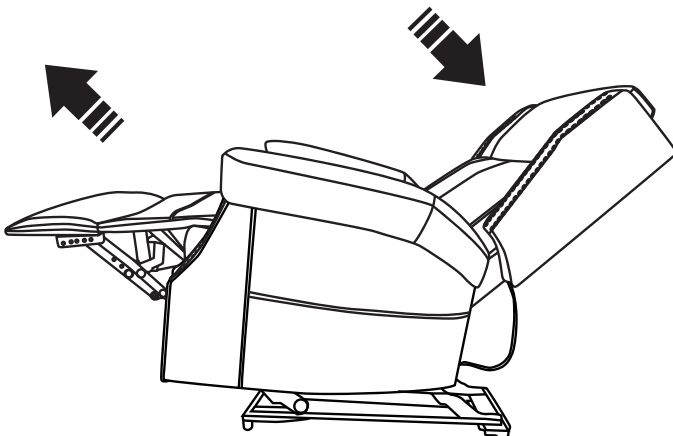

# How to get footrest latch down?

1. Sit on the chair (not recline), backrest will be back.  
Press the bottom of footrest with some strength (with feet) ,  
try some times to get footrest latch down

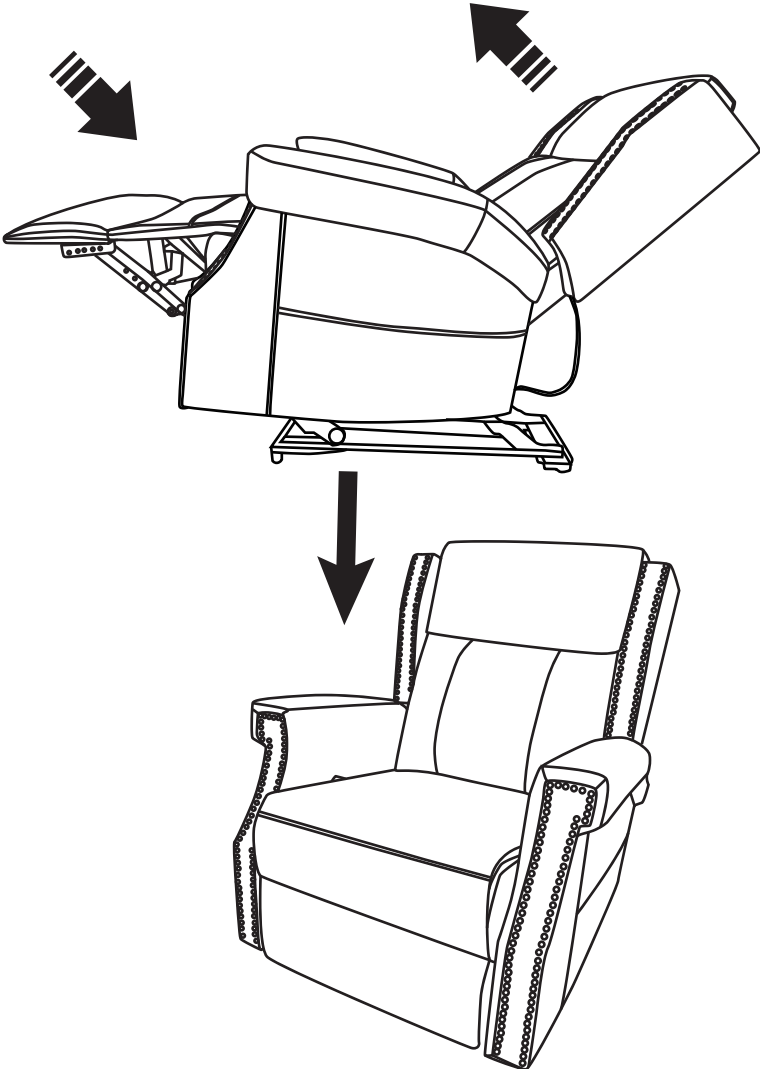

## How to use remote control?

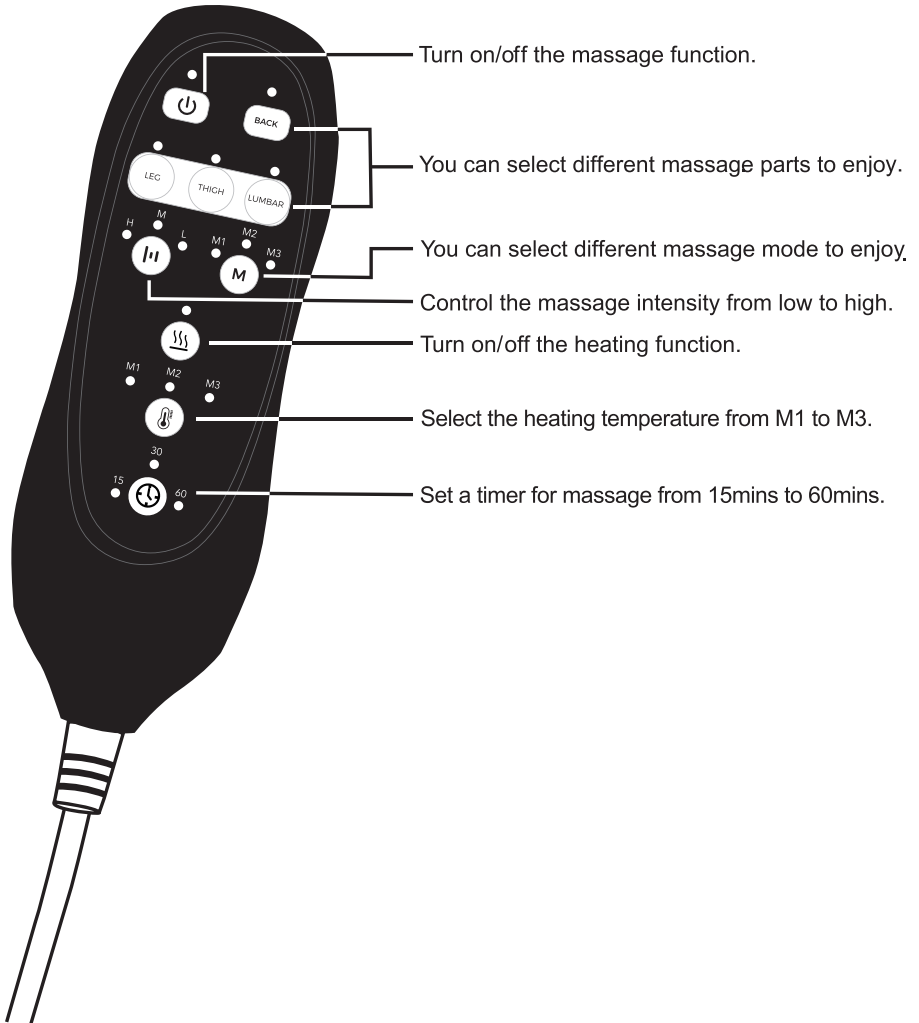

# FAQ

## Q1: Missing parts when received.

A: If you find some parts are missing from the box, please kindly send us messages to let us know the name of missing part regarding to the first page of instructions. We will send replacement to you asap.

## Q2: Some parts damaged when arrived.

A: Please send clear photos about damaged part to us as attachment, we will check and offer you best solution soon.

## Q3: How to release footrest and recline?

(1) There is a black handle in the right side of the chair, please lift it up with some strength, then the footrest will pop up. Then you can lie in the chair with some strength about your back so that the back of the chair will recline too.

(2) When the footrest releases, please sit in more deeper of the seat, not just in front of the seat, also put two hands on both armrests, then lie down and use both back and hands strength, it will be much easier.

Note: The chair can not always keep in reclined position when you leave the chair.

## Q4: How to make the footrest go back down?

(1) Please try to keep the back of the chair in the seated position, it's a new chair so need more strength to lock down and you can try some times to close footrest with some force and it will work. When you hear a click sound, footrest closed.

(2) Another solution is get out of the chair and try to push the footrest back with your hands. And it will be much easier after several times use, please note it.

## Please note that you need to take apart the backrest before.

1. Pull out the ears from the back
2. Pull up the buckles firstly while take the backrest out from the base.
3. Then pull out the arms from the base.

