

ASSEMBLY INSTRUCTION











DESCRIPTION: ARM CHAIR

Read instruction carefully prior to assembly .

Thank you for purchasing this quality product. Check carefully for small parts which may have come loose during shipment.

Remove all components from pack and place table top upside down on soft surface such as carpet or cloth to prevent scratching the finish. Identify and count all parts as specified below.

Do not tighten bolts until assembly is complete

NO.	HARDWARE PACK	Q'TY	NO.	PARTS LIST	Q'TY
A	 ALLEN BOLT (Ø5/16"×75mmL)	4PCS	1		CHAIR BACK 1PC
B	 ALLEN BOLT (Ø5/16"×60mmL)	4PCS			
C	 ALLEN BOLT (Ø5/16"×45mmL)	6PCS	2		CUSHION SEAT 1PC
D	 LOCK WASHER (Ø5/16")	14PCS			
E	 FLAT WASHER (Ø5/16")	14PCS	3		LEG 2PCS
F	 ALLEN KEY (4MM)	1PC			
G	 VIS 4X45MM	2PCS	4		ARM CHAIR (R+L) 2PCS

STEP: 1

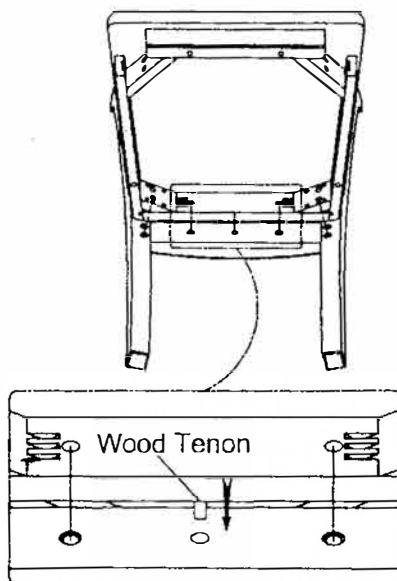

STEP: 2

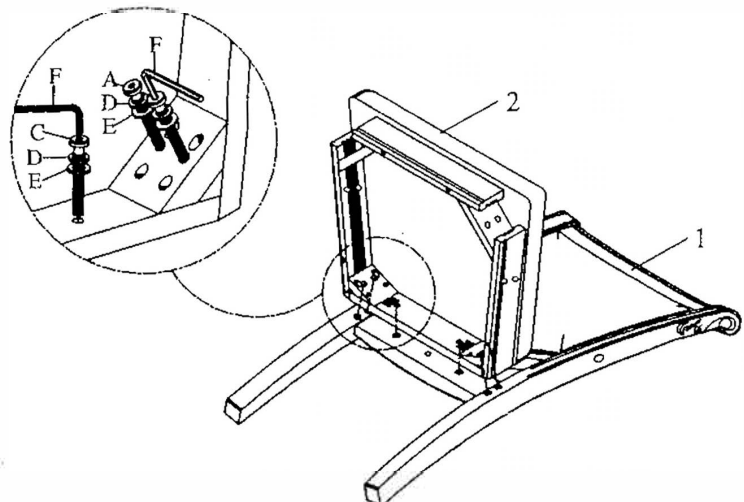

ASSEMBLY INSTRUCTION

STEP:3

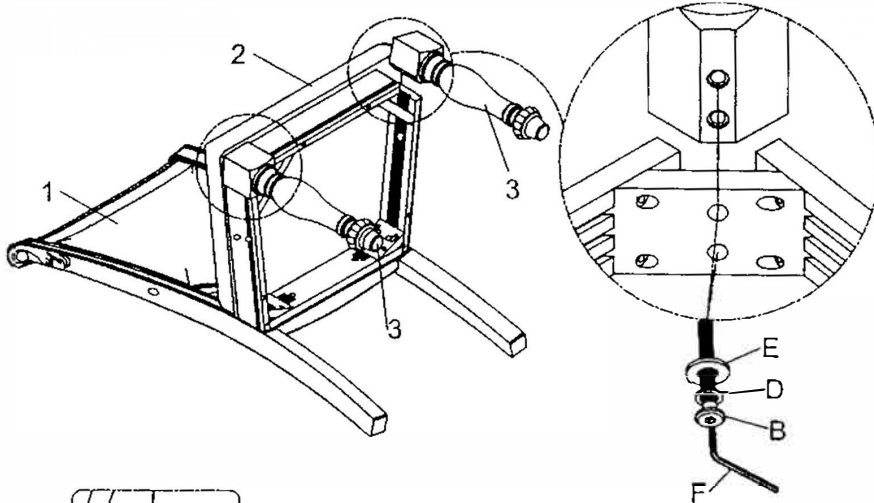

STEP:4

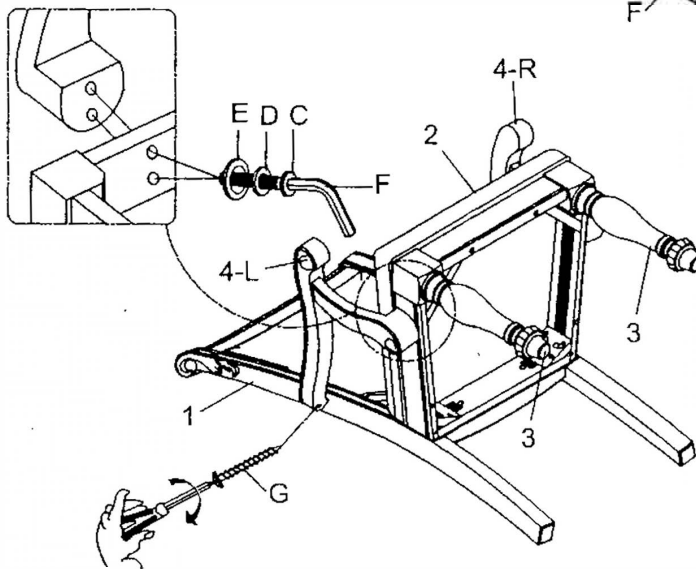

STEP:5

Assembly Completed

