

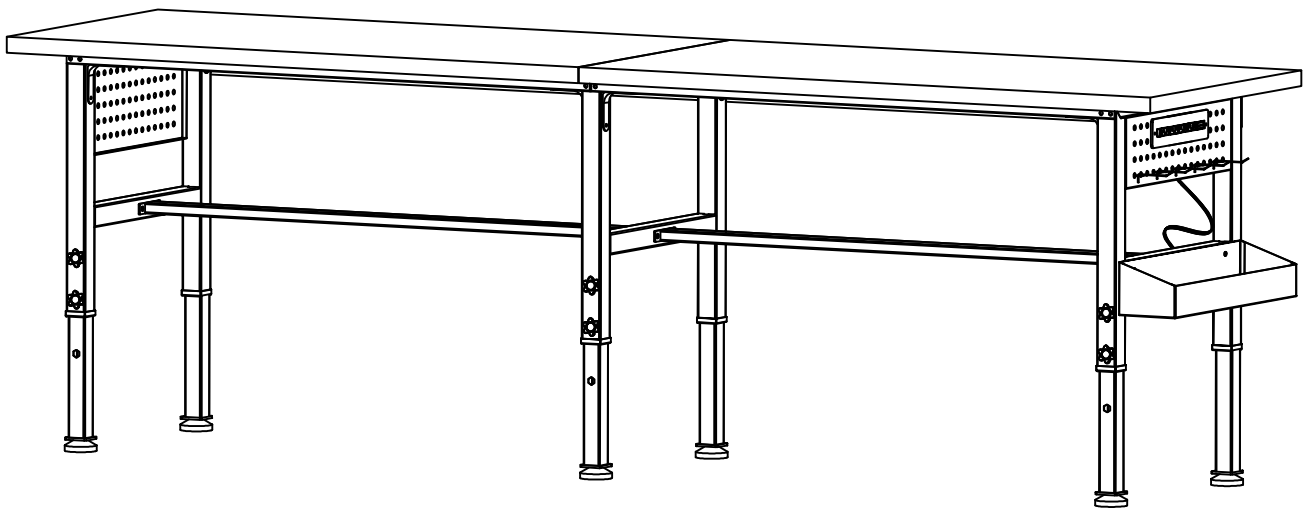







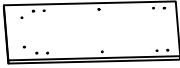
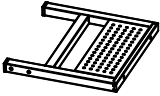
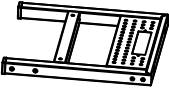
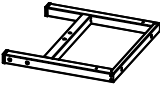

Installation Manual





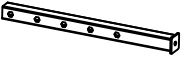

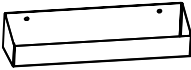



96" Adjustable Work Bench



Customer Service: ahomrt@163.com

Parts List

Number	Parts	Quantity
1		2PCS
2		1PC
3		1PC
4		1PC
5		1PC
6		1PC
7		1PC
8		1PC
9		2PCS
10		8PCS
11		6PCS
12		1PC
13		6PCS 6PCS
14		1PC
15		10PCS 10PCS

Number	Parts	Quantity
A		12PCS
B	 M8x35	10PCS
C	 M6x16	10PCS
D	 M8x20	20PCS
E	 M6x12	10PCS
F	 M8	1PC
G	 M8x16	18PCS
H	 M4x12	18PCS
I	 M6x12	2PCS
J	 M6	1PC
K	 M12	1PC

Note: This product is recommended for installation by two people

Step 1



B x 4



D x 4



F x 1



1 x 2



2 x 1





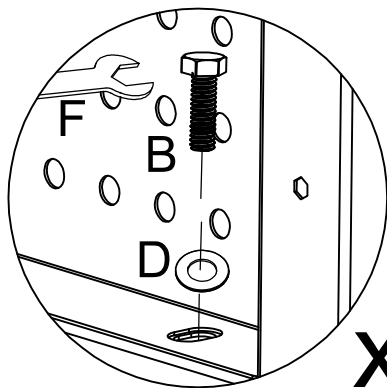
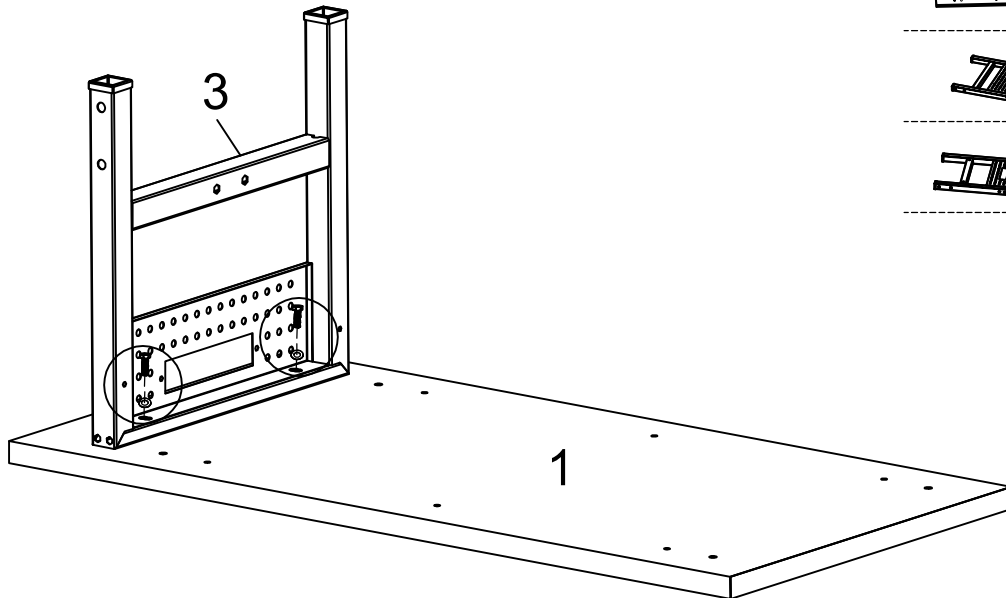



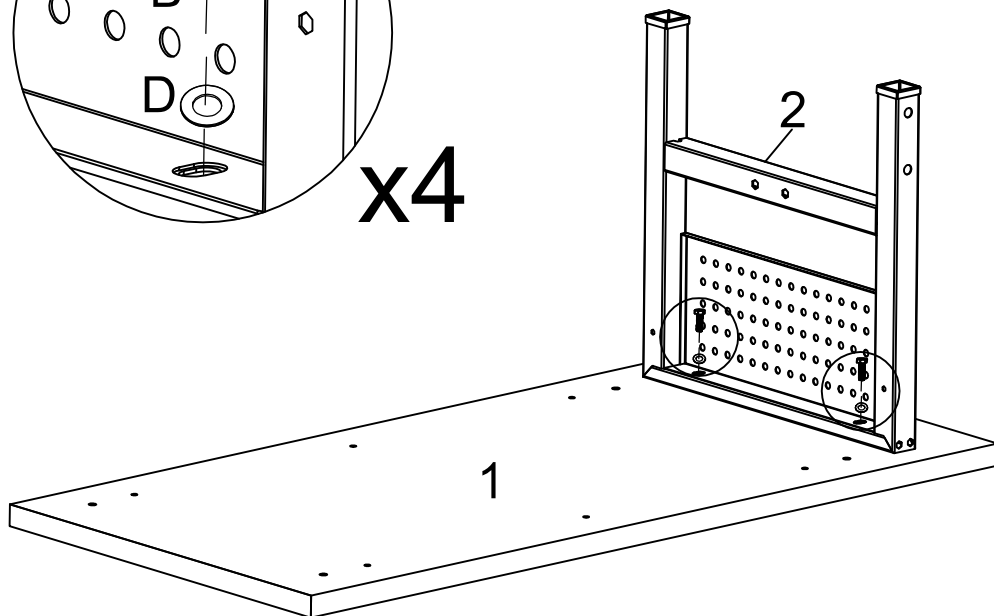

3 x 1



Note: Do not tighten the screws until step 4 is complete









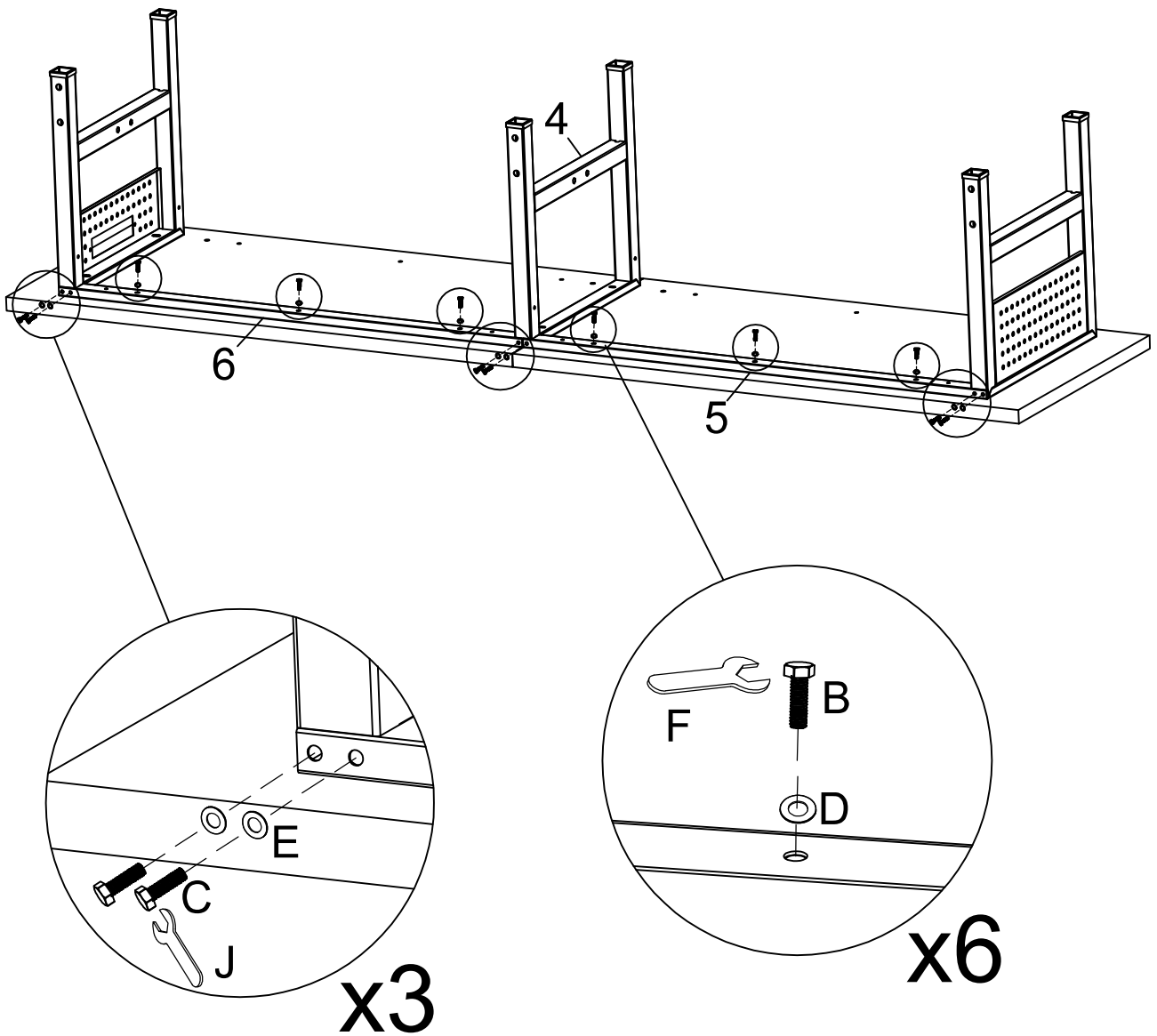

Step 2

	4 x 1		B x 6
	5 x 1		D x 6
	6 x 1		F x 1
			C x 6
			E x 6
			J x 1

Note: Do not tighten the screws until step 4 is complete



Step 3

	7 x 1		G x 10
	8 x 1		D x 10
			F x 1
			C x 4
			E x 4
			J x 1

Note: Do not tighten the screws until step 4 is complete

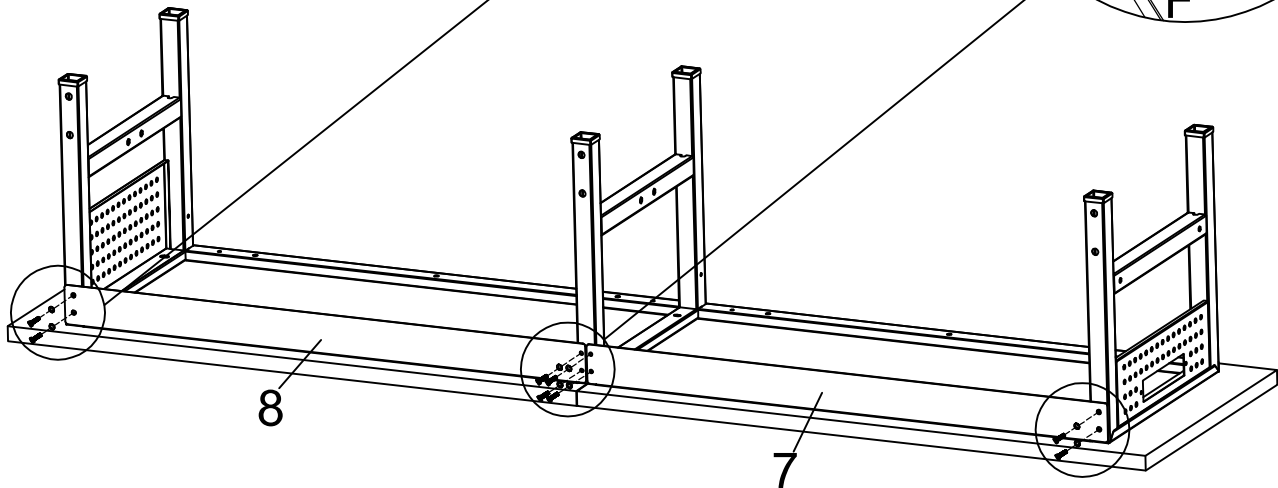
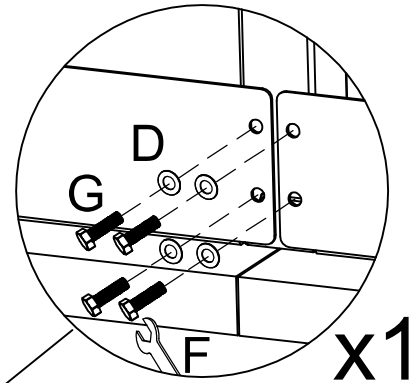
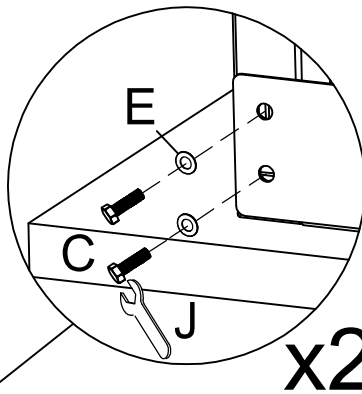
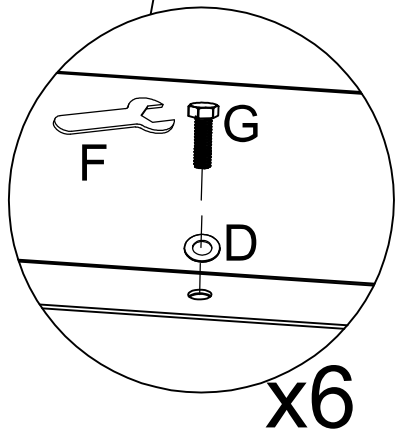
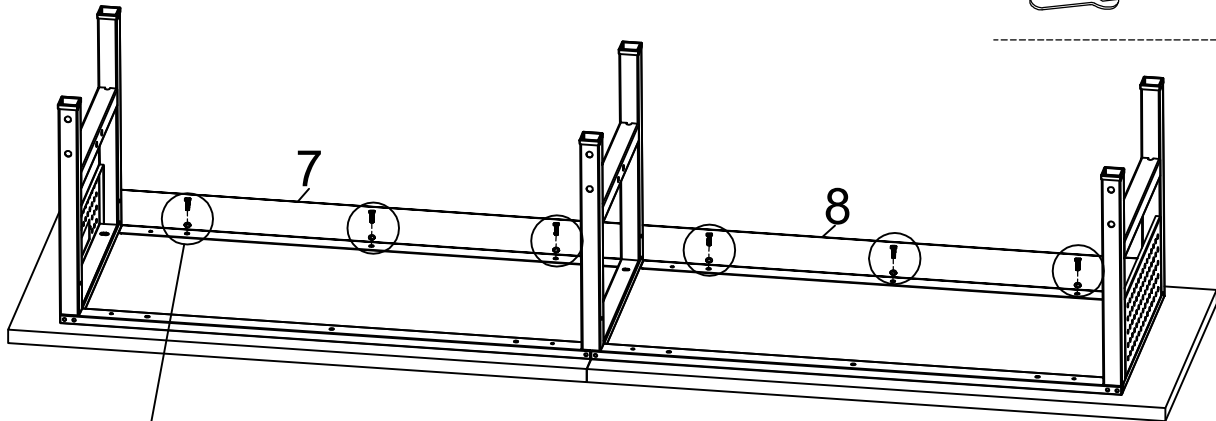

Step 4



G x 8



F x 1



9 x 2

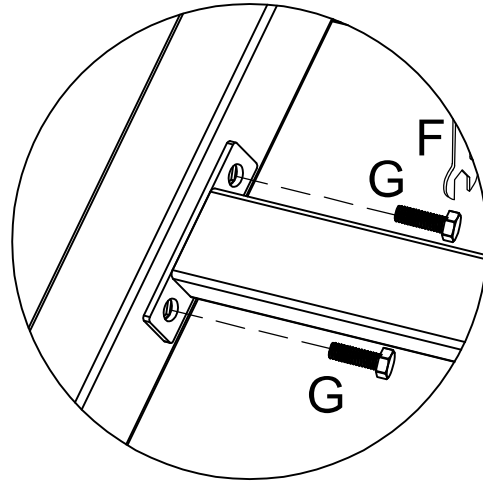

x4

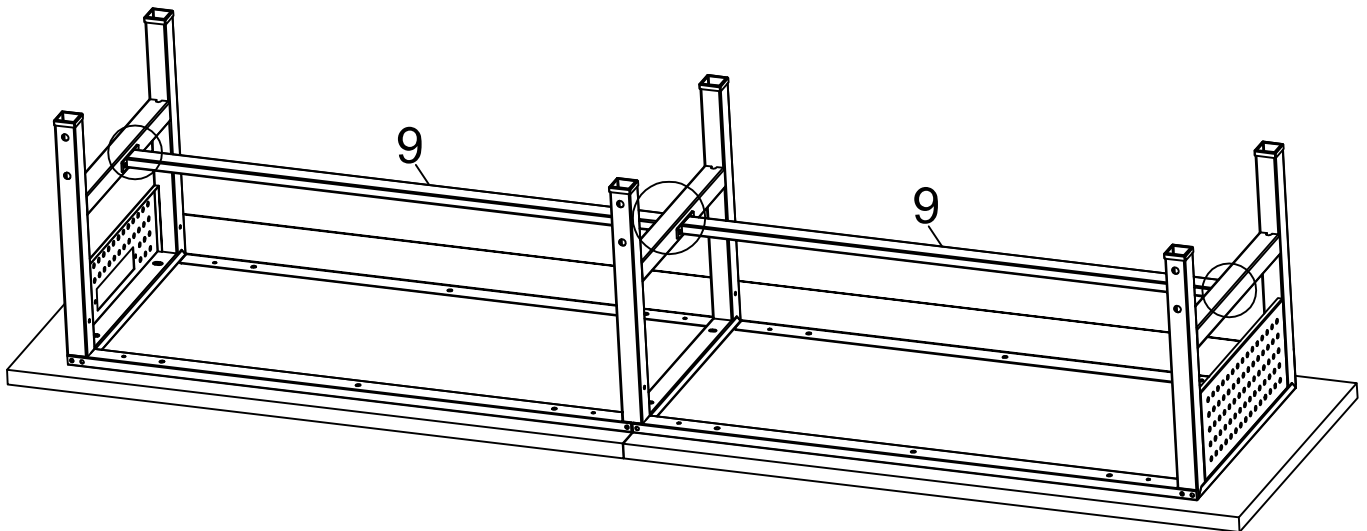

Attention: Please tighten all screws that were not tightened in steps 1, 2, and 3

Step 5



H x 16



10 x 8

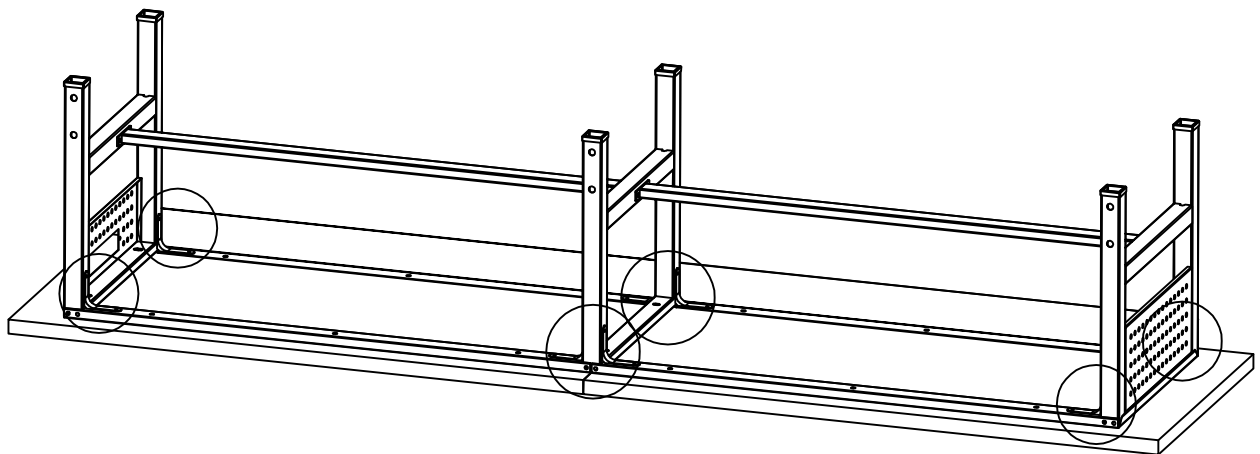
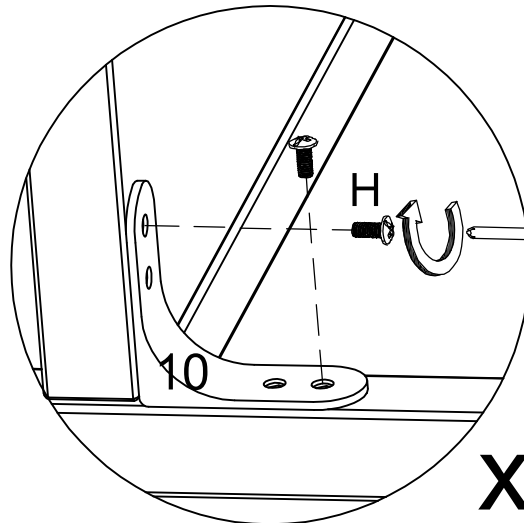

Step 6



A x 12



11 x 6

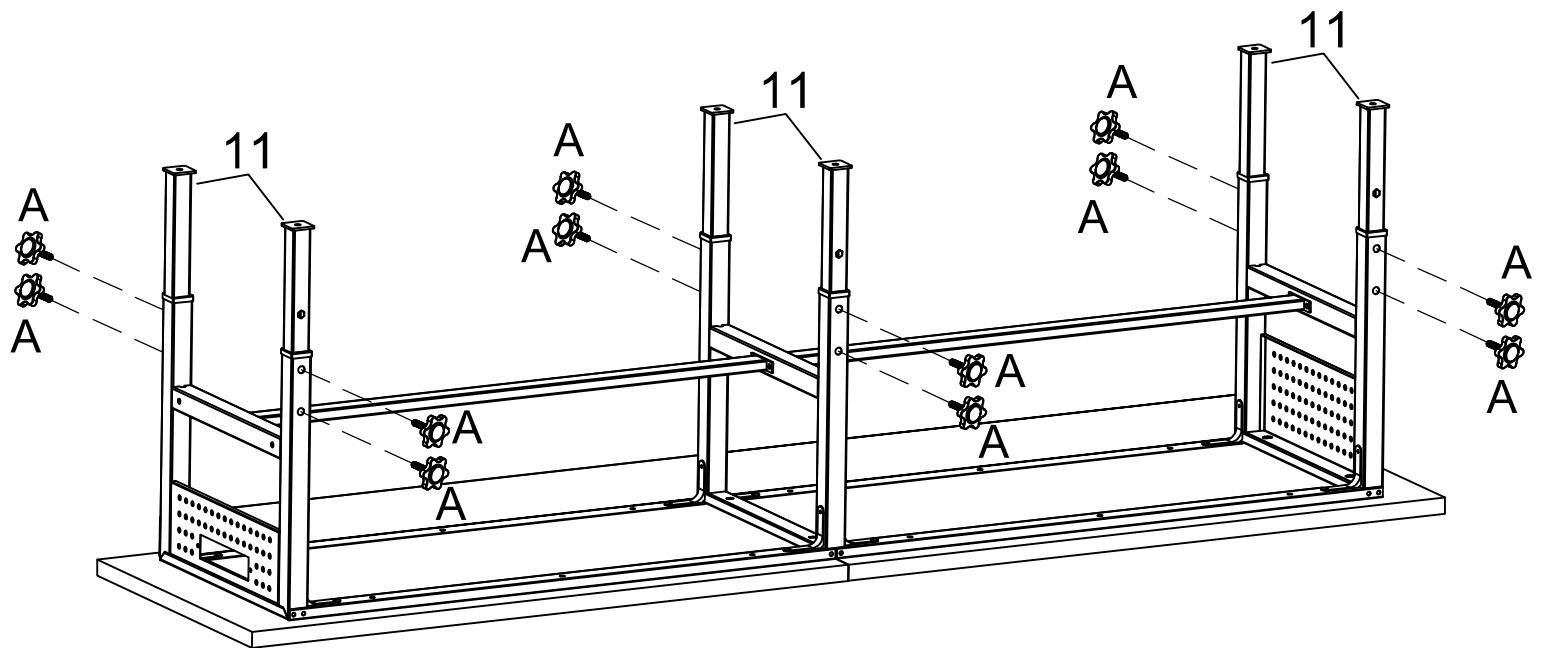

Tip: The table legs are adjustable to multiple heights, and you can set them to your desired height according to your needs

Step 7



13 x 6



K x 1

Tips: Both types of NO.13 parts are included. Please install according to your needs

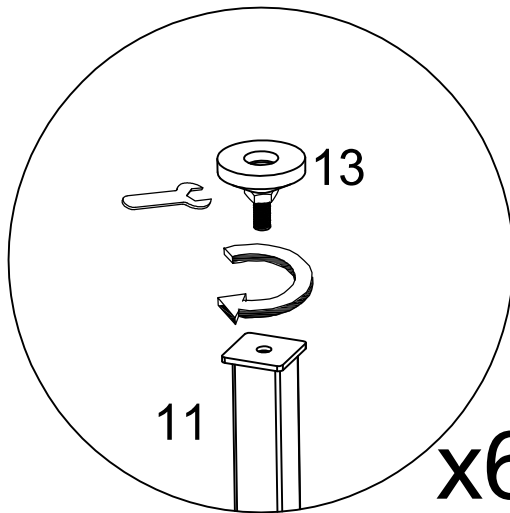

or

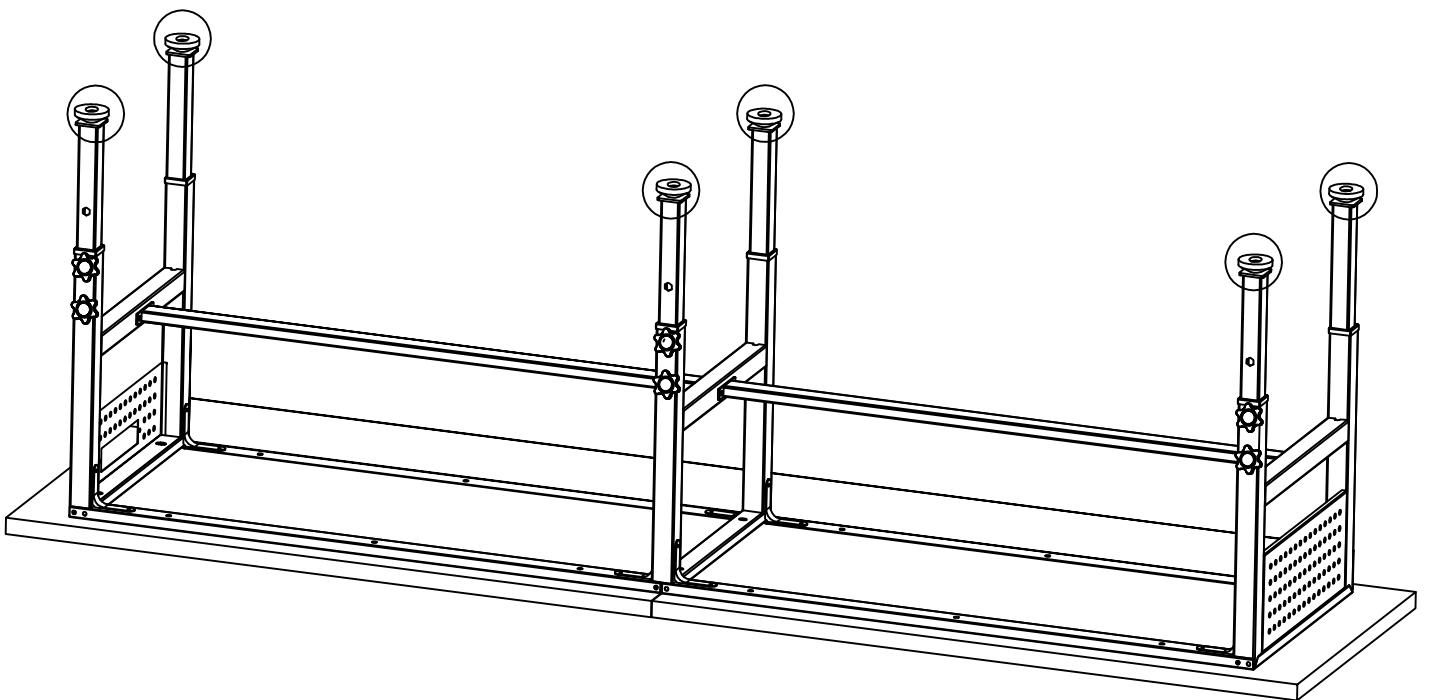
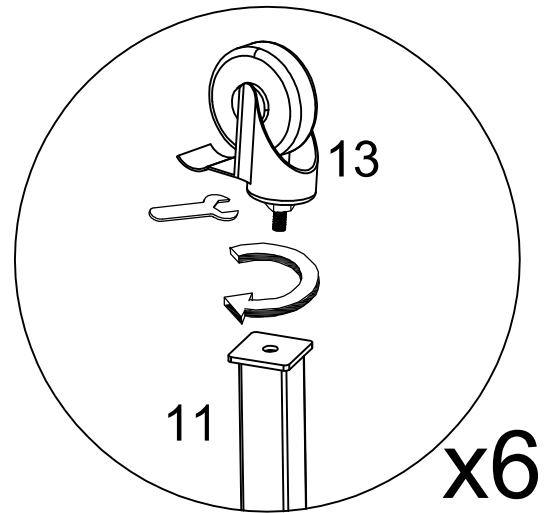

Step 8



H x 2



12 x 1

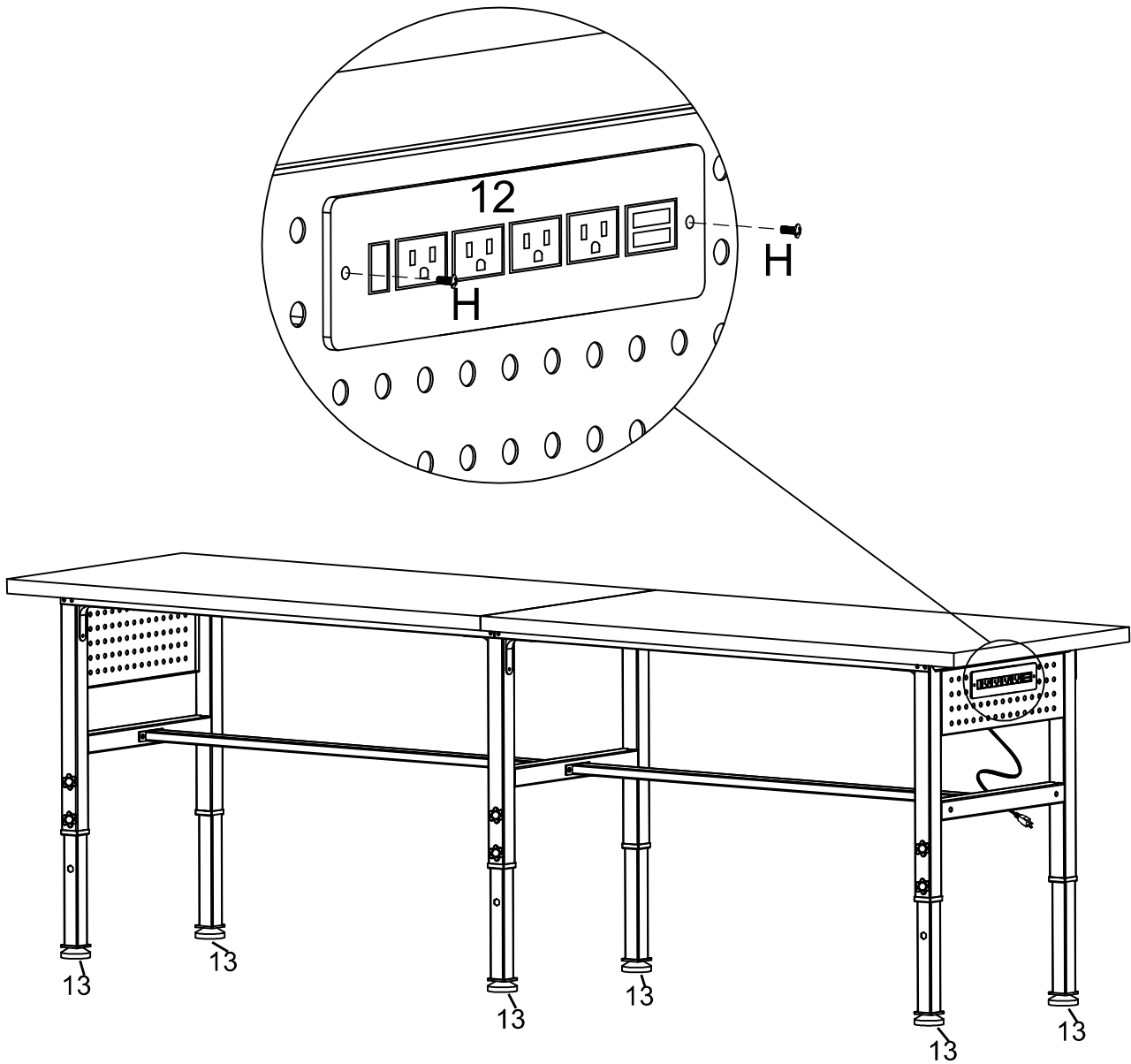

Note: In the event of an uneven floor, the tabletop may not remain level after installation. To correct this, adjust the height of Part No.13 (the adjustable foot) until the product is stable. After adjustment, use Part K to tighten the nut on Part No.13 to secure the position and ensure maximum stability

Step 9



1 x 2

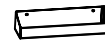

14 x 1

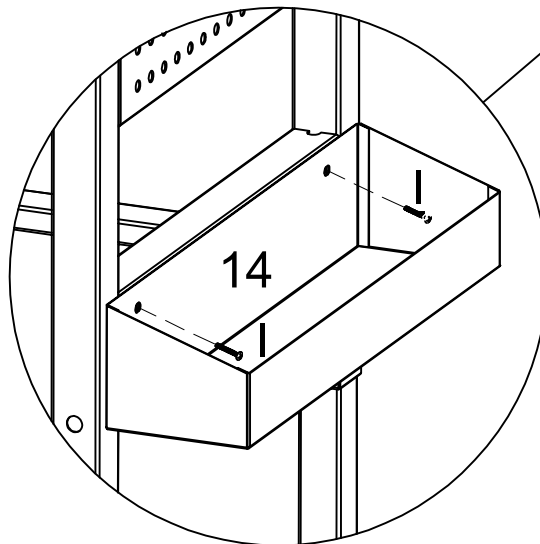
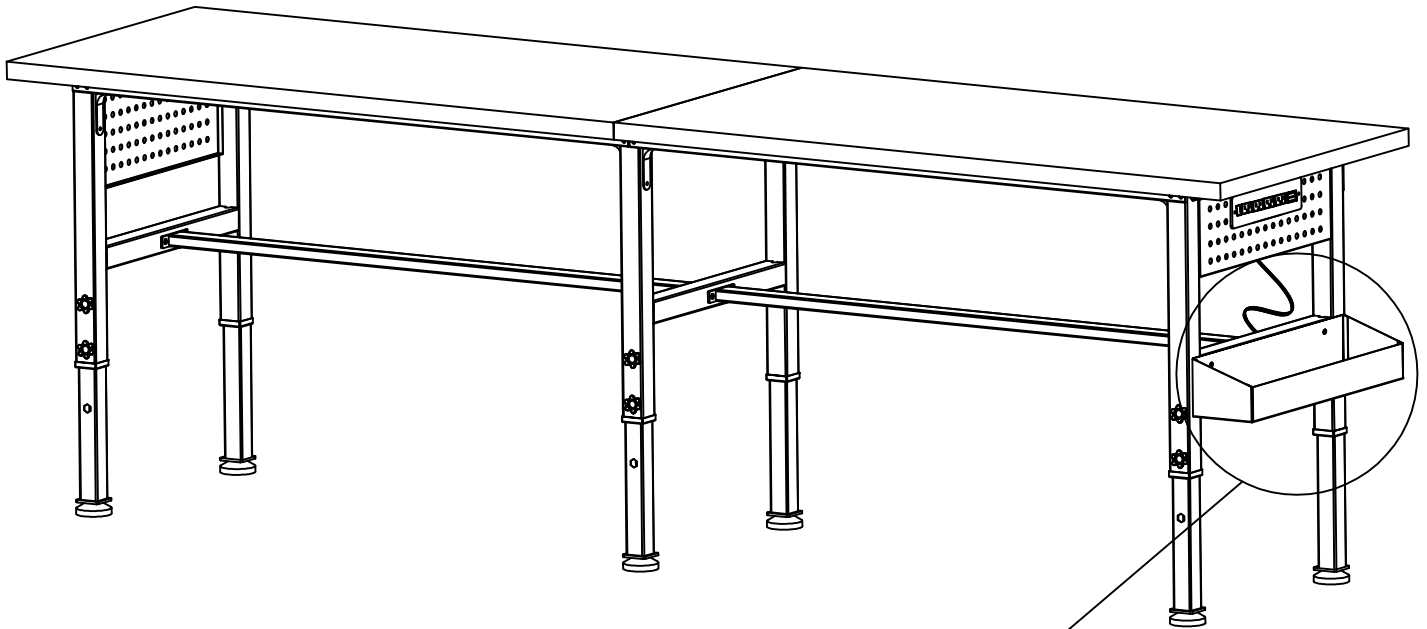

Step 10

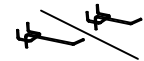

15 x 10

Tips: We have provided sufficient 15-type parts.
Please choose and use them according to your
requirements

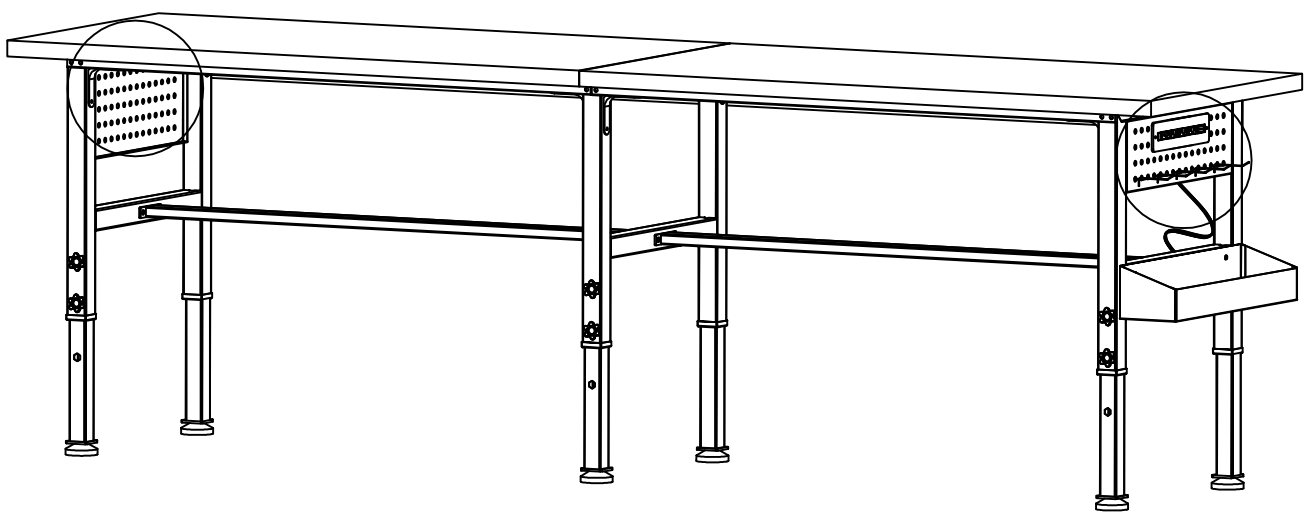
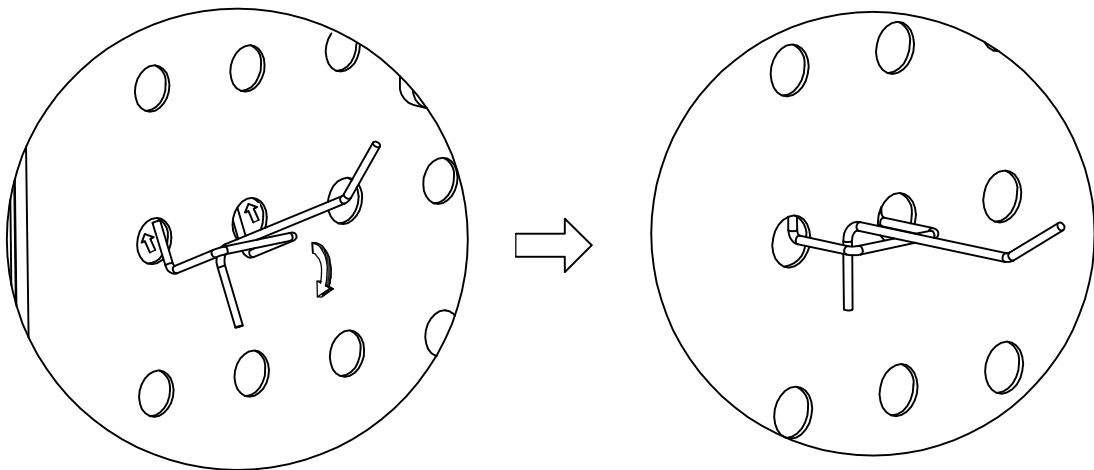

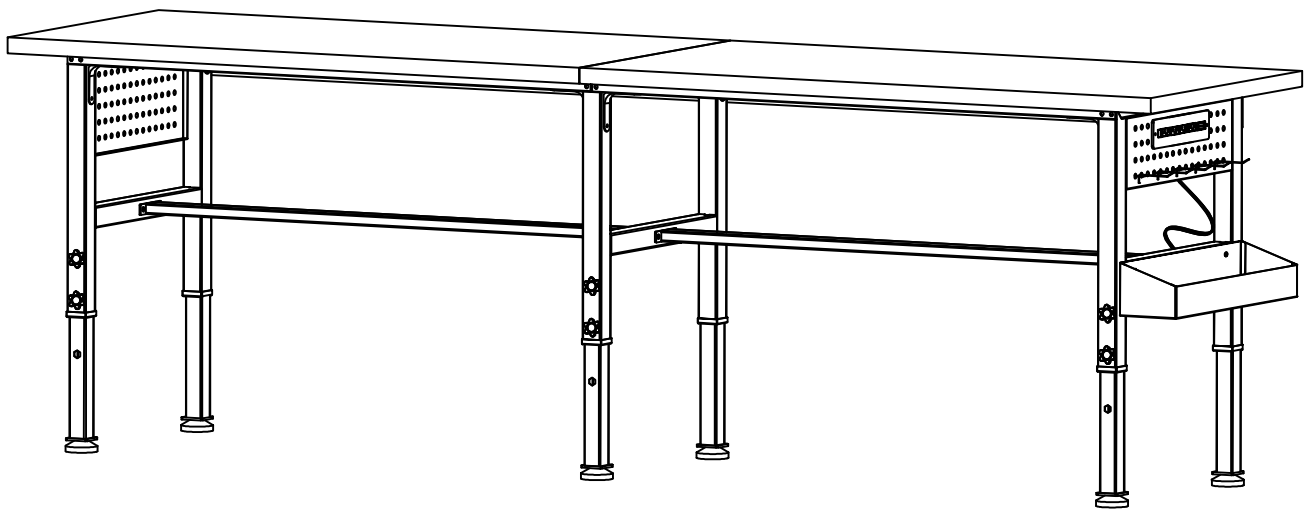

Final Assembly