

ASSEMBLY INSTRUCTION













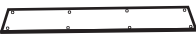





Read instructions carefully prior to assembly.

Thank you for purchasing this quality product. Check carefully for small parts which may have come loose during shipment.

Remove all components from pack and place table top upside down on soft surface such as carpet or cloth to prevent scratching the finish. Identify and count all parts as specified below.

Do not tighten bolts until assembly is complete.

HARDWARE LIST

NO.	PART	DESCRIPTION	Q'TY	NO.	PART	DESCRIPTION	Q'TY
A		glass top	1	I		small washer	8
				J		small screw nut	8
B		glass bottom	2	K		holder	1
				M		screw	2
C		rod	8	N		metal rod	2
D		big stainless tube	16	O		allen key	1
E		short stainless tube	8	P		big washer	2
F		plastic gasket	32	Q		big screw nut	2
				R		spring washer	1
G		chrome feet	8	S		small hexagon spanner	2
H		plastic feet	8	T		big hexagon spanner	1

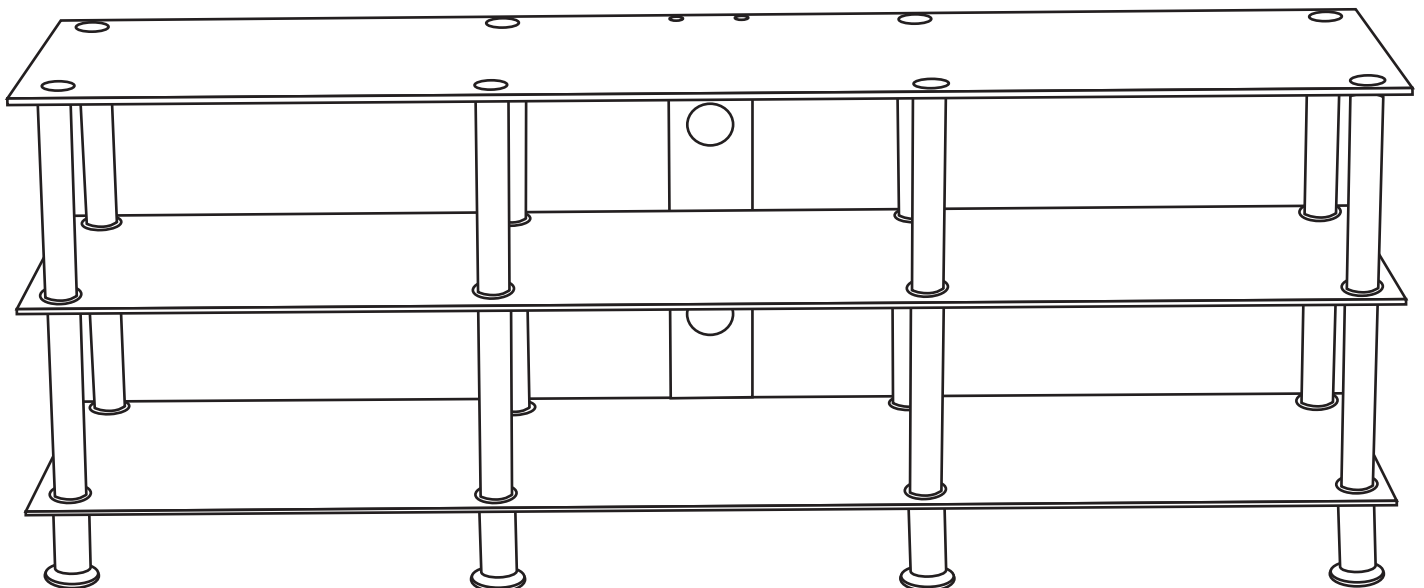

ASSEMBLY INSTRUCTION

setp 1

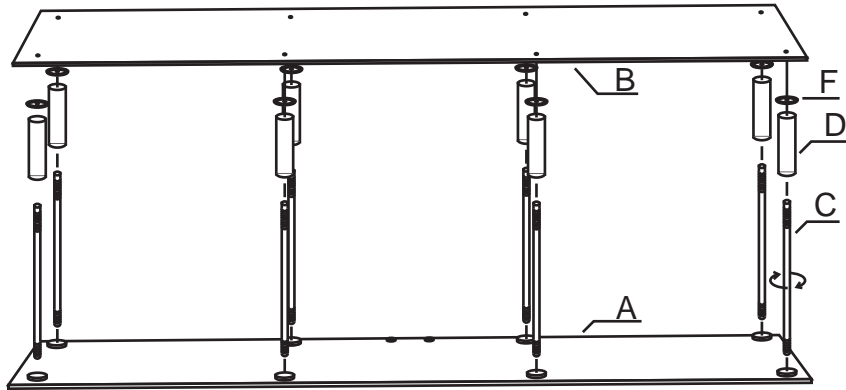

setp 2

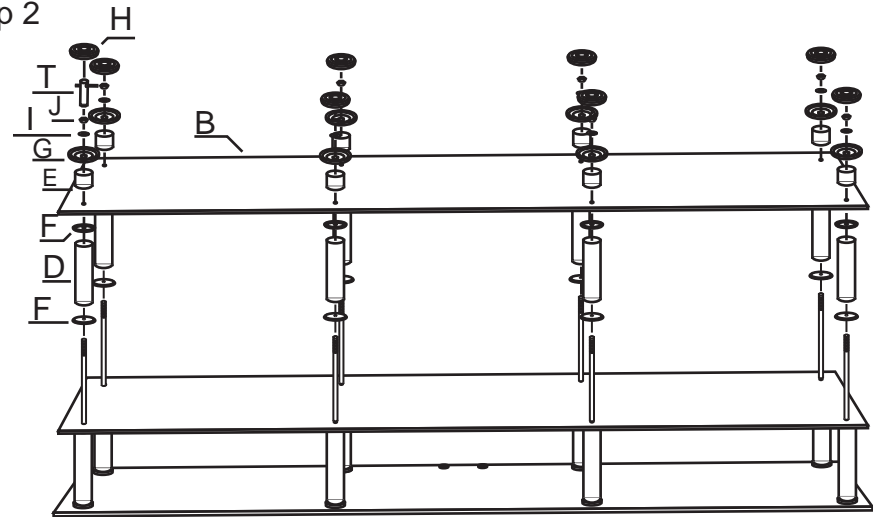

setp 3

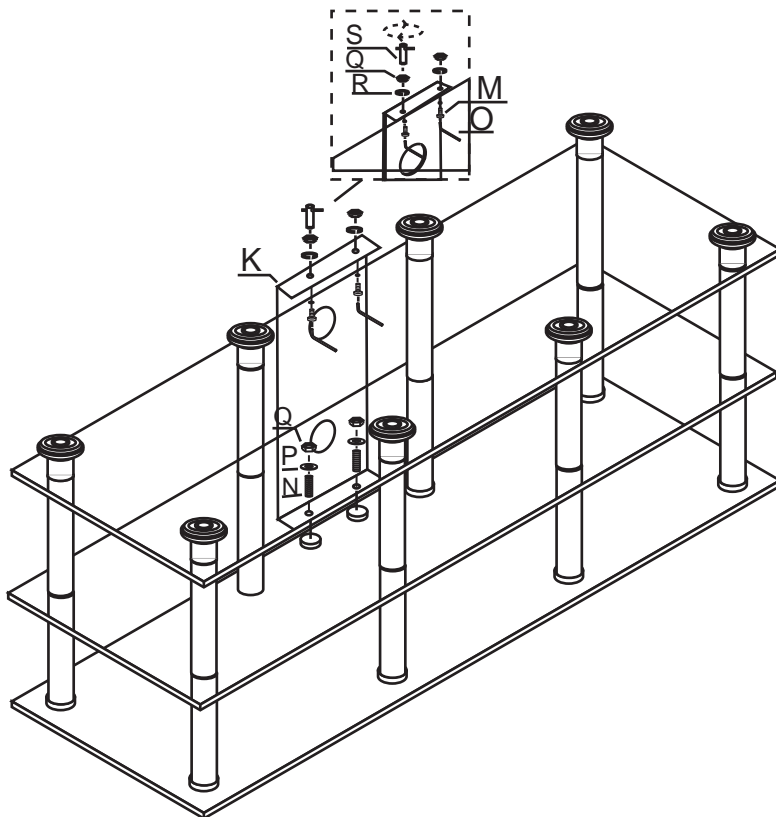

setp 4

