

Assembly Instructions

Caution: You must read this before you proceed

Table

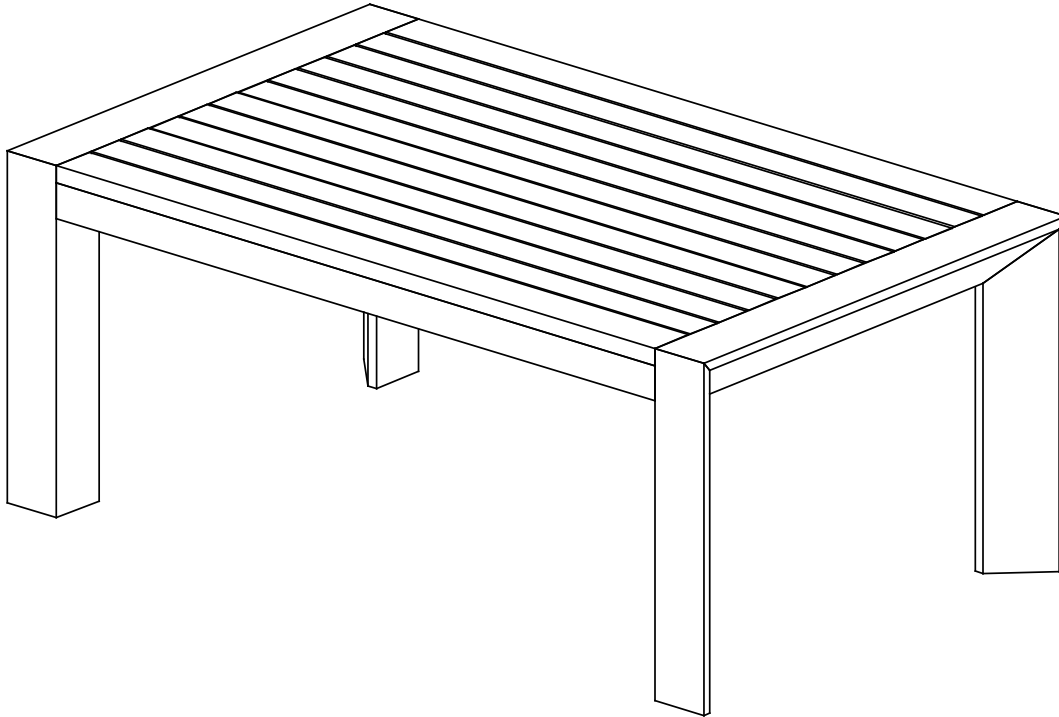

Caution: This Table is NOT a TOY.



Keep your child/children at bay during the assembly process.

Whenever moving/lifting the Table and to prevent damage to the Table, two adults are required to execute these actions.

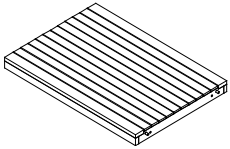
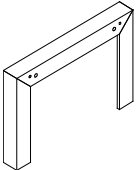
Part List

Label	Picture	Description	QTY
A		Table Top	1
B		Leg (with Pre-installed Levellers)	2

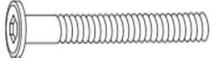
Hardware

Label	Picture	Description	QTY
①		Bolt (M8x35mm)	5
②		Allen Key	1

Assembly Preparation

Before Beginning Assembly:

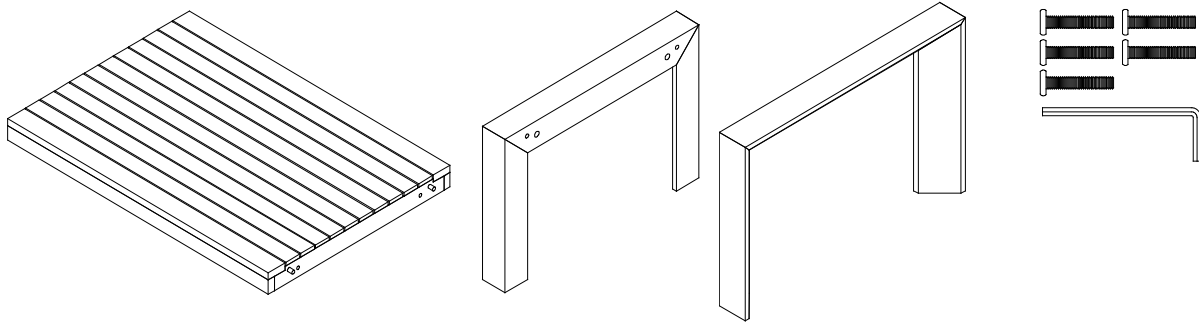

- Read instructions, cover to cover-



- Have 2 adults on hand for assembly-



- Do not assemble on flooring or carpet-



- Assemble on a clean non-marring surface (packing foam)-



- Save all packaging until finished-

Assembly Steps

Overview

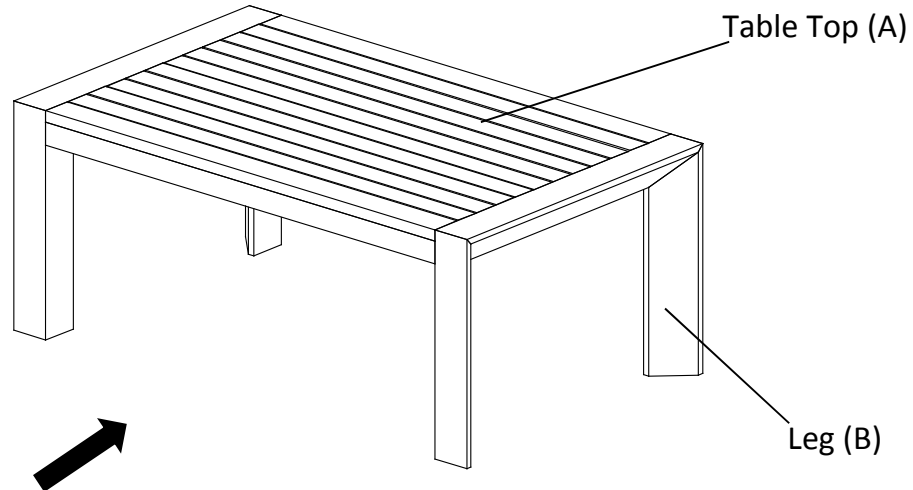

FRONT FACING

This Table has multiple parts and may require up to 30 minutes to assemble. To give you an overview of the Table parts, the above picture is to help you put the various parts into perspective. Please read through the instructions below to familiarise yourself with the parts and steps before assembly.

Step 1

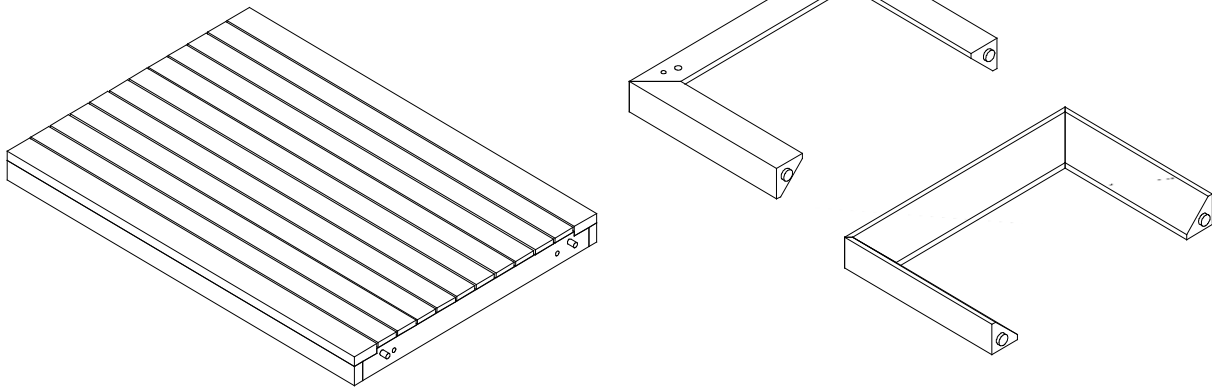

Unplace and place all parts on a clean, non-marring surface.

Step 2

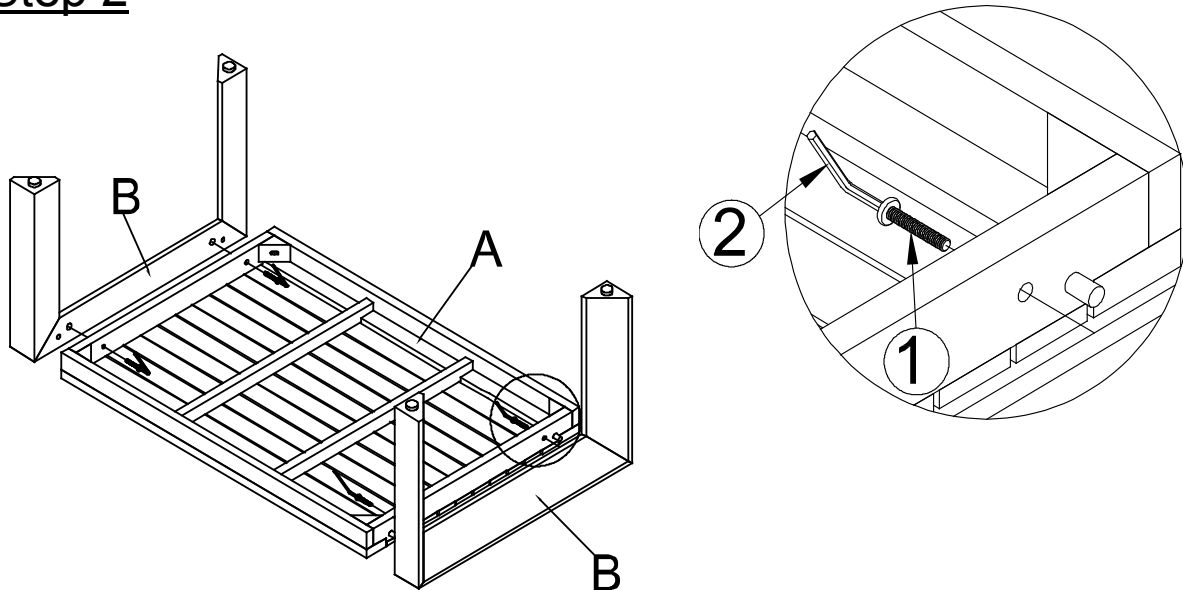

Place the Table Top(A) facedown as shown above.

Insert the wooden tenons on Table Top (A) to the housing on Leg (B) as shown above.

Then attach the Legs (B) to Table Top(A) using Bolts(①) with Allen Key(②) as shown in picture above.

Do not fully tighten the Bolts.

Step 3

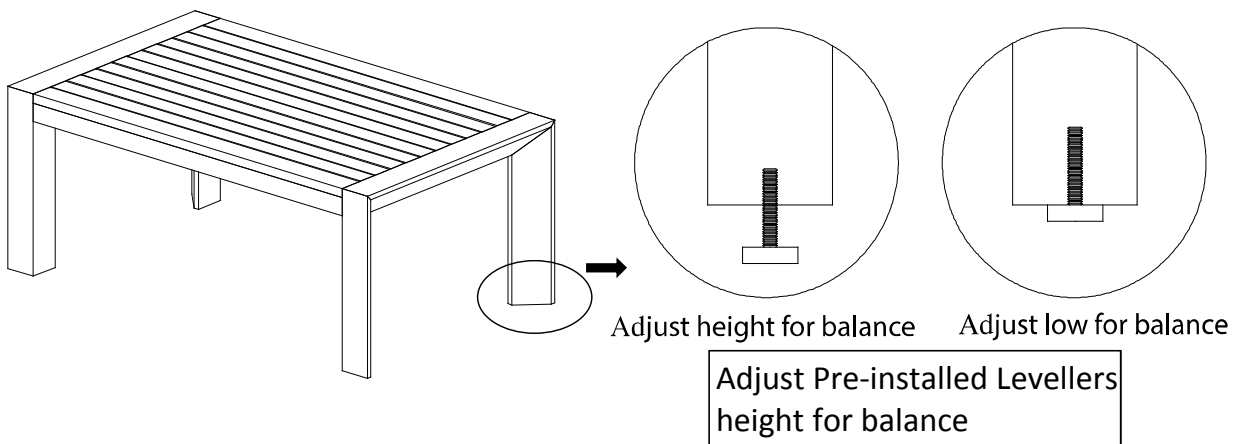

Place the Table onto a flat, level surface.

Then EXERT pressure, floorwards onto the Table with both hands.

This pressure will help the Table reach full alignment at all joints.

In a sequential manner, gradually tighten all Bolts at all joints until evenly secured.

Inspect the Table and make sure all parts are adequately connected.

Adjust the Levellers until the Chair is level with the ground.

To adjust the Levellers, get assistance from an adult partner to lift/lean and hold the Chair while you are working.



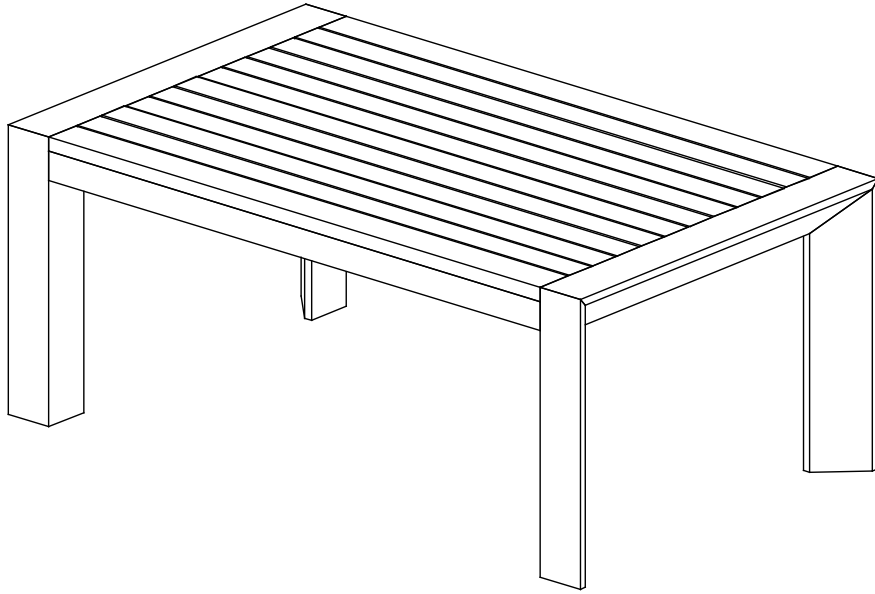





Step 4



Your Table is ready for use.

This Table can only be used on a flat, level surface.

Care & Maintenance

-  ● Do not put hot items directly on furniture surface
 -  ● Do not clean furniture with harsh cleansers or polish.
 -  ● To obtain the longest lifespan of your outdoor products, minimizing exposure to direct sunlight is recommended.
 -  ● Children should not climb or jump on the furniture.
 -  ● Do not write on furniture without a padded barrier to protect the surface.
 -  ● To obtain the longest lifespan of your outdoor products, avoid extended and lengthy exposure to rain, snow, and direct sunshine. Whenever possible cover the product and /or place under patio or awnings.
 -  ● Not for commercial use. For residential use only .
 -  ● Stains may be removed with mild soap solution and damp cloth.
-
-  ● Dust and pick-up spills using a clean, non-colored, lint-free cloth .