

ASSEMBLY INSTRUCTIONS

DESK WITH HUTCH

ASSEMBLY
REQUIREMENTS

2-Person
Assembly

1.5 Hours
Assembly Time
(Approximate)

Assembly Tools
Required
(Not Provided)

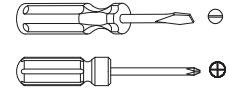

Thank you for purchasing our product!

Please refer and use this assembly instruction to assemble the product. Contact our customer service department in case there are any missing or damage parts or hardware. Replacement parts are normally shipped within 2 or 3 days.

Within 30 days from delivery date

PRODUCTS PURCHASED THROUGH OUR AUTHORIZED VENDORS ONLY ARE ELIGIBLE FOR REPLACEMENT PARTS.

We appreciate your business!

THIS PRODUCT IS FOR INDOOR AND HOUSEHOLD USE ONLY- NOT FOR COMMERCIAL USE.

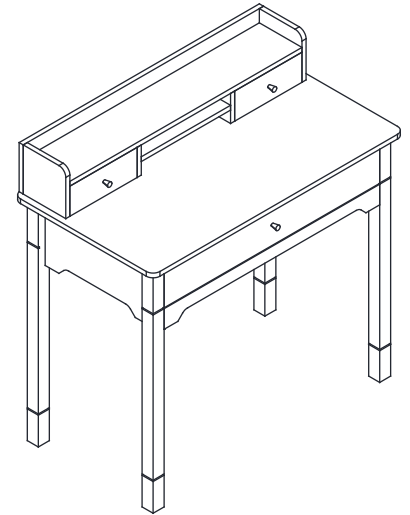

ASSEMBLY PREPARATION

1. Remove all packaging materials, staples and packing straps from the carton.
2. Refer to Parts List and Hardware List, and ensure parts and hardware are correct before assembly. Contact customer service for missing parts.
3. Place all wooden parts on a clean, flat and soft surface (e.g. carpet or rug) to prevent scratch and damage to parts.

SAFETY PRECAUTION

1. KEEP ALL HARDWARE PARTS OUT OF REACH OF CHILDREN.
2. DISPOSE PLASTIC PACKAGING MATERIAL IMMEDIATELY TO AVOID ANY RISK OF SUFFOCATION TO CHILDREN AND ANIMALS.

TIPS FOR ASSEMBLY

1. Allow ample room for assembly and assemble the product near where the product will be placed.
2. Assemble the product on a surface that does not scratch or damage the exterior gloss and finish of the furniture
3. Identify all of the parts, hardware and quantities required for each step.
4. During assembly, do not over-tighten any fittings as this may cause damage.
5. DO NOT USE POWER TOOLS TO ASSEMBLE THIS PRODUCT.
6. Always place the product on a flat, level surface.
7. Do not sit or stand on the partially assembled product; only use the product for which it is intended.

CARE AND MAINTENANCE

- Wipe clean with a soft, dry cloth; avoid the use of harsh chemicals or household cleaners as they may damage the exterior finish of the furniture.
- Hardware may loosen over time. Periodically, check that all connections are tight; re-tighten as necessary.
- Solid wood is impacted by heat and humidity fluctuations which may cause small joint separations or hairline cracks; place the furniture away from direct sunlight and air conditioning vents, heating vents or units to protect the furniture.

ASSEMBLY INSTRUCTIONS

DESK WITH HUTCH

Parts List

Part #	Part Name	Quantity	Part #	Part Name	Quantity
(1)	Desk Top Panel	1	(11)	Hutch Fixed Shelf Panel	1
(2)	Left Frame	1	(12)	Hutch Top Panel	1
(3)	Right Frame	1	(13)	Hutch Back Panel	1
(4)	Back Panel	1	(14)	Drawer Bottom Support Rail	1
(5)	Front Support Rail	1	(15)	Drawer Left Panel	1
(6)	Bottom Support Rail	1	(16)	Drawer Right Panel	1
(7)	Hutch Left Panel	1	(17)	Drawer Back Panel	1
(8)	Hutch Left Divide Panel	1	(18)	Drawer Bottom Panel	1
(9)	Hutch Right Divide Panel	1	(19)	Drawer Front Panel	1
(10)	Hutch Right Panel	1	(20)	Hutch Drawer	2

Parts Assembly Overview

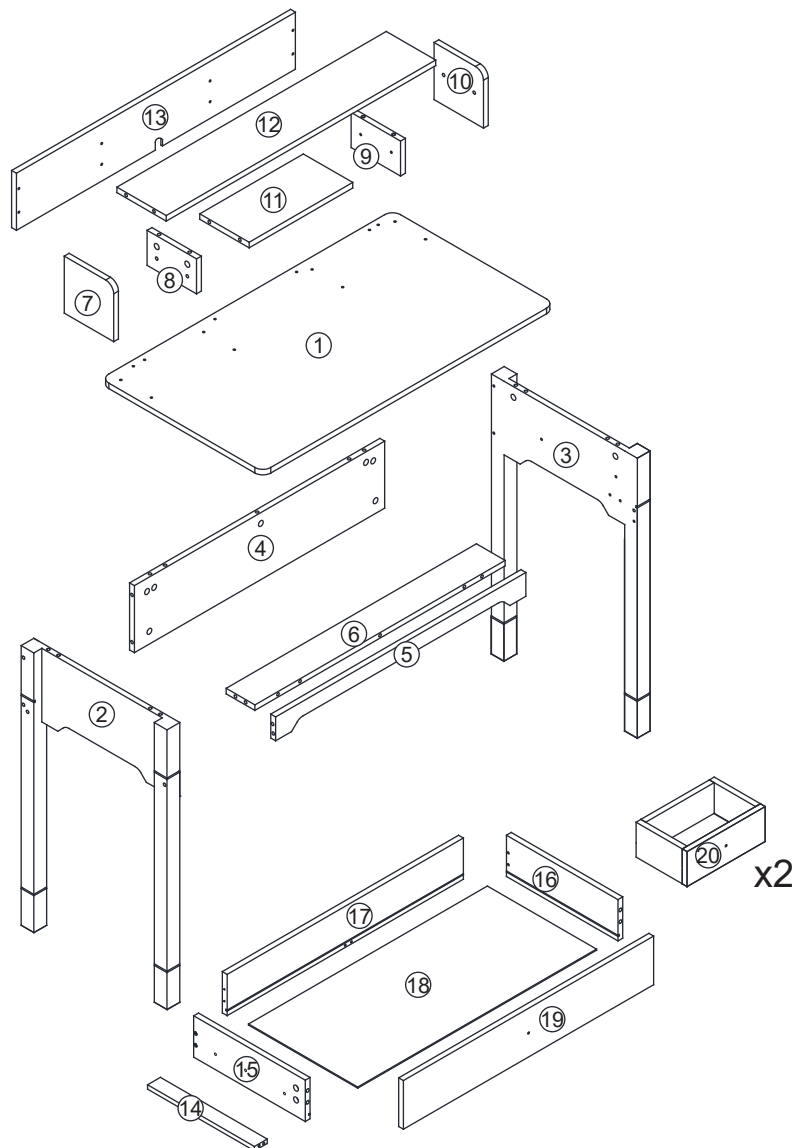

ASSEMBLY INSTRUCTIONS

DESK WITH HUTCH

Hardware List

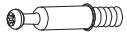

A

28 PCS

Cam bolt
ø6x35



B

28 PCS

Cam lock
ø15x10



C

12 PCS

Wood Dowel
ø6x30mm



D

30 PCS

Screw
ø4x35mm



E

10 PCS

Screw
ø3x12mm

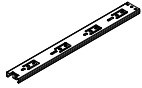

Fx2 PCS

2 PCS

Drawer Slide



G

3 PCS

Knob



H

3 PCS
Handle Bolt
ø4x18mm

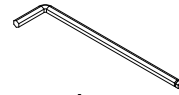

I

1 PC

Allen Key M4



J

6 PCS

Bolt
ø6x70mm



K

Kx6 PCS
Nut



L

6 PCS
Sticker

INSTRUCTIONS FOR CAM-BOLT AND CAM-LOCK

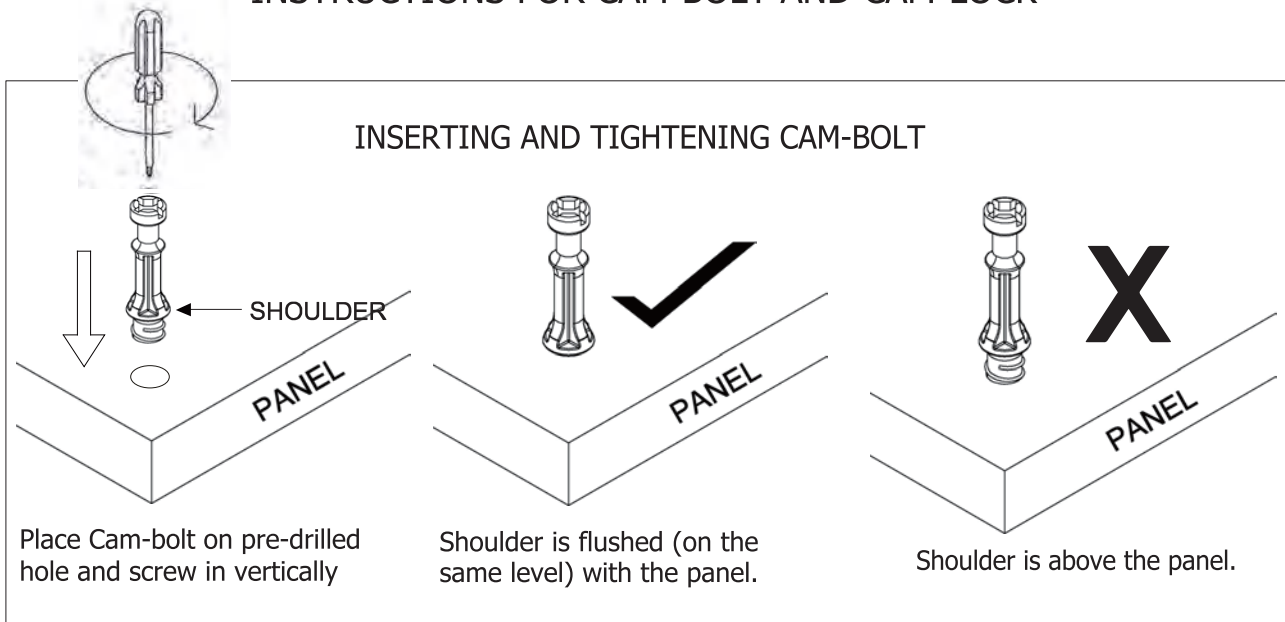

Place Cam-bolt on the designated pre-drilled holes on the panel. Use a Phillips Screwdriver to screw-in Cam-bolt vertically until shoulder is flushed (on the same level) with panel. Do not over-tighten or under-tighten.

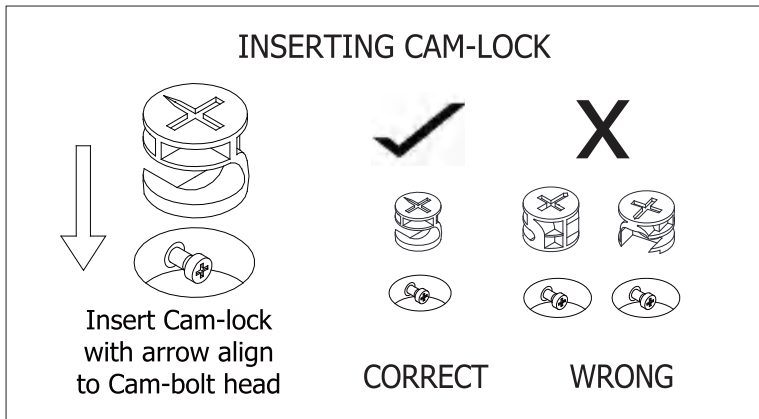

Align the arrow on the Cam-lock to the Cam-bolt head and insert the Cam-lock. Ensure inserted Cam-lock is flushed with the panel.

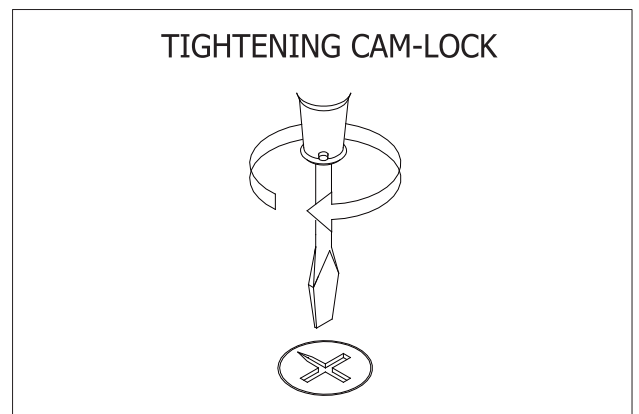

Use a Flat Screwdriver to turn Cam-lock clockwise so it locks onto the head of the Cam-bolt. Turn until it is snug (about one half a turn) -- over-tightening could damage Cam-lock or/and Cam-bolt.

Instructions For Installing Barrel Nut

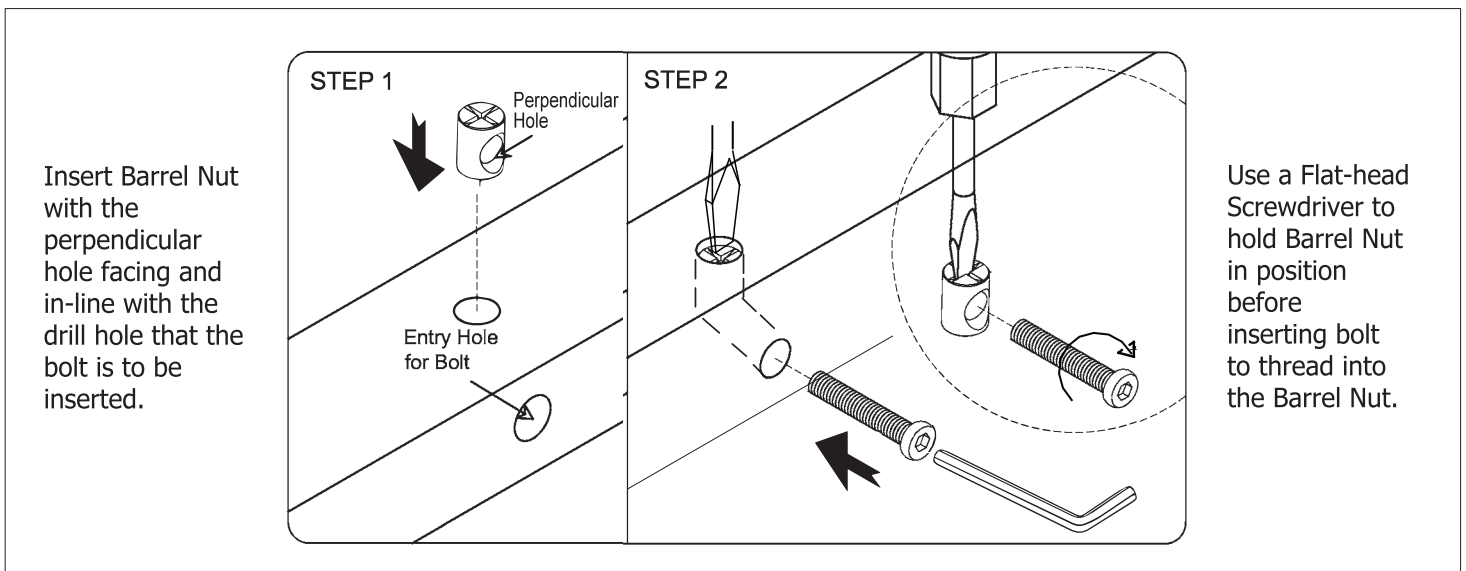

ASSEMBLY INSTRUCTIONS

DESK WITH HUTCH

STEP 1

Separate Drawer Track (F1) and Drawer Runner (F2) of Drawer Slide

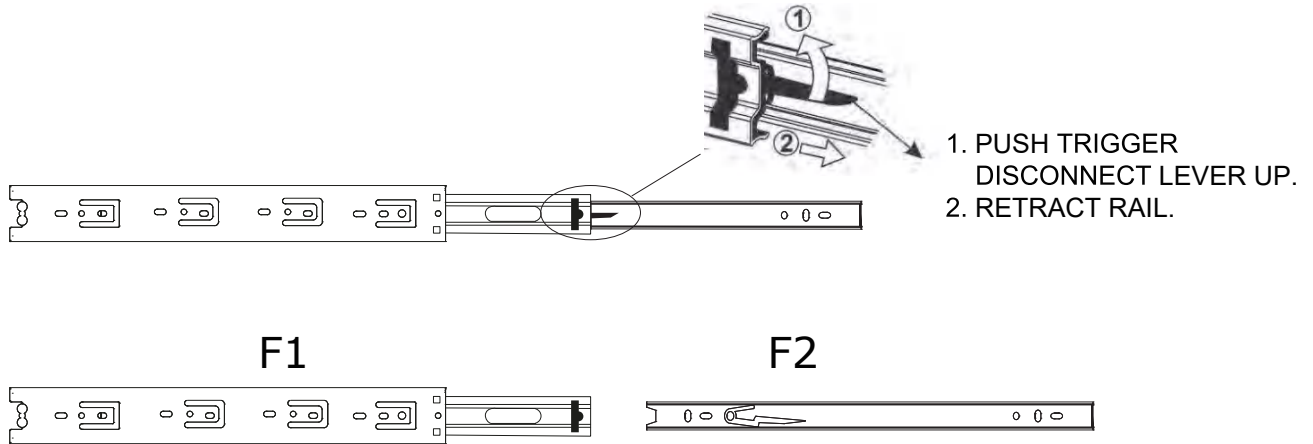

Procedure

1. Distinguish between Slide Track (F1) and Slide Runner (F2) of Drawer Slide (F).
2. Slide out (F2) from (F1) until Trigger Disconnect Lever is visible.
3. Push up or depress the Disconnect Lever in the groove of (F2) and at the same time slide out (F2) completely from (F1).
F1 will be used in the next step while (F2) will be used until STEP 15.

STEP 2

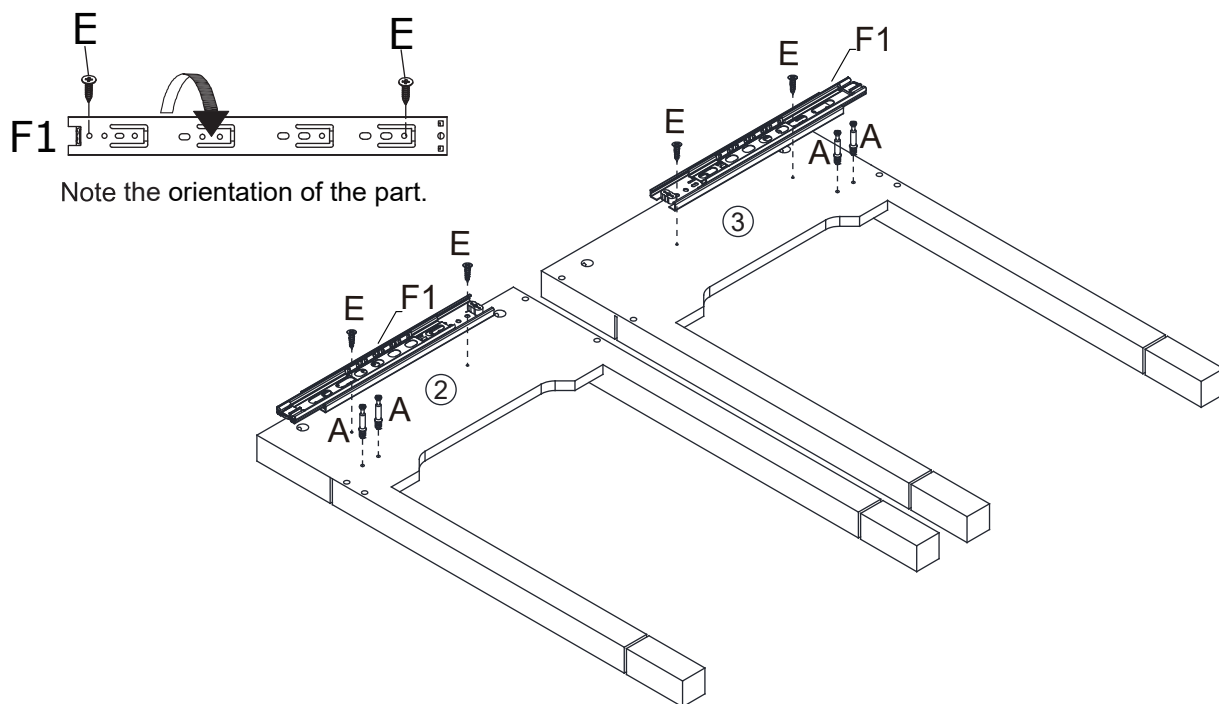

A	x4
ø6x35mm	
E	x4
ø3x12mm	
F1	x2

- a) Place Left Frame (2) and Right Frame (3) as shown on a material that does not scratch or damage the part.
- b) Screw in Cam-bolt (A) into the designated holes on as shown. Refer to page 4 for instruction on inserting and tightening Cam-bolt.
- c) Fasten F1 to (2) and (3) with Screw (E).

ASSEMBLY INSTRUCTIONS

DESK WITH HUTCH

STEP 3

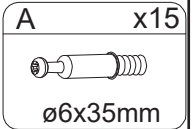
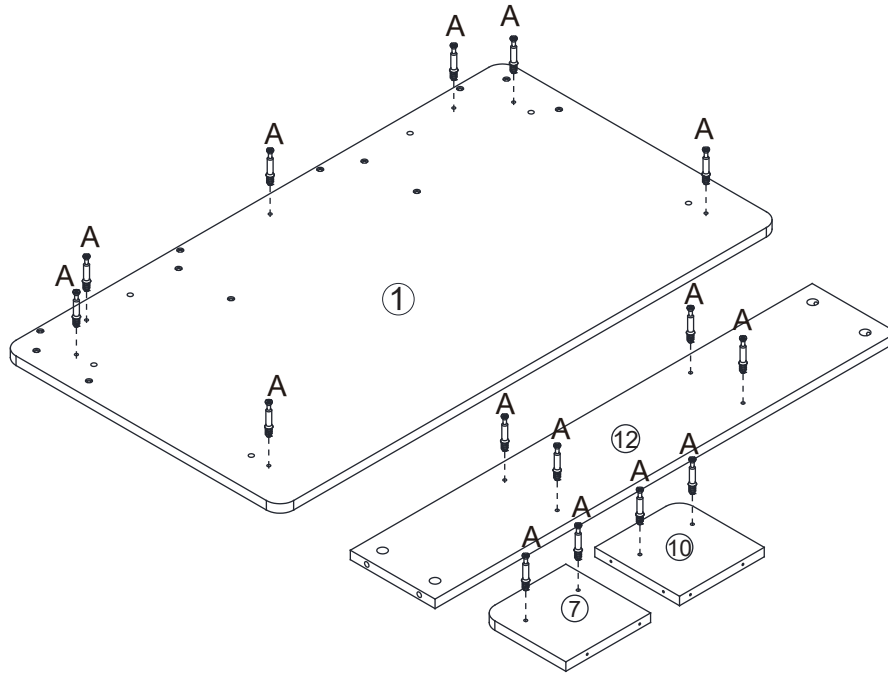

- Place Desktop Panel (1), Hutch Top Panel (12), Hutch Left Panel (7) and Hutch Right Panel (10) as shown on a material that does not scratch or damage the parts.
- Screw in Cam-bolt (A) into the designated holes on (1, 12, 7 & 10).

STEP 4

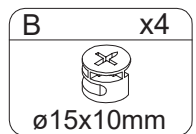
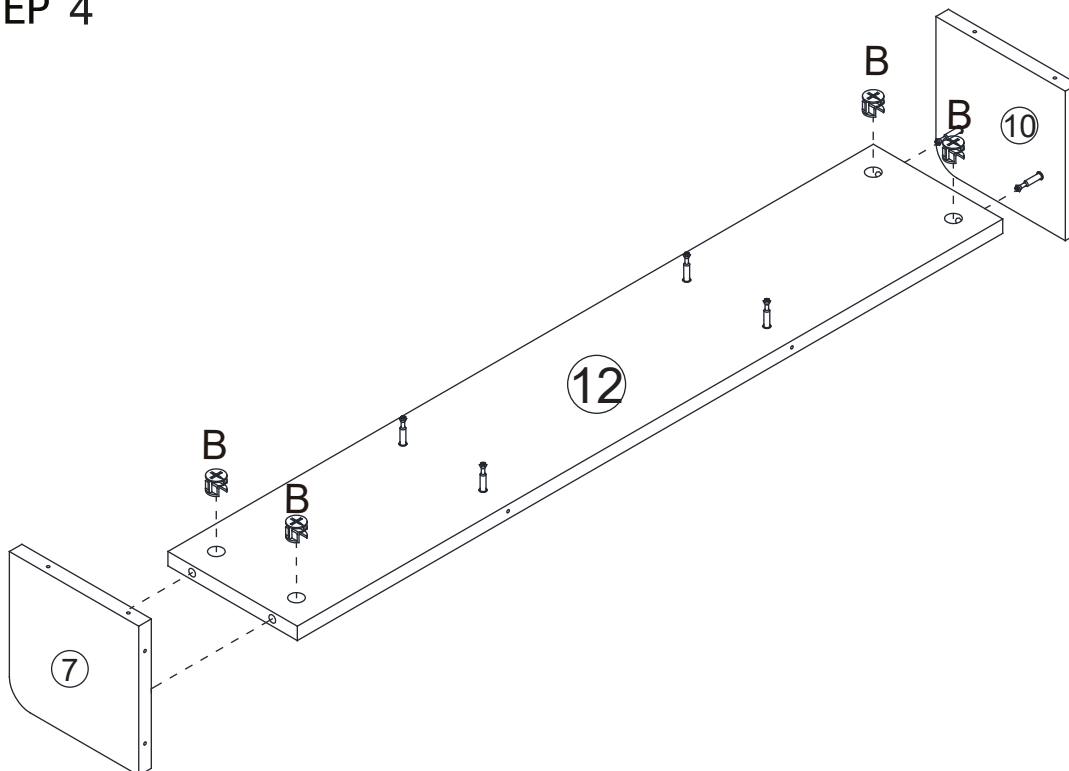

- Attach Hutch Left Panel (7) and Hutch Right Panel (10) at each end of Hutch Top Panel (12) via Cam-bolt.
- Insert Cam-lock (B) into the designated holes below the holes where the Cam-bolts are inserted. Use Flat Screwdriver to turn (B) clockwise to lock onto Cam-bolts. Refer to Page 4 for instructions on inserting and tightening Cam-lock.

ASSEMBLY INSTRUCTIONS

DESK WITH HUTCH

STEP 5

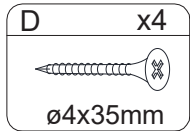
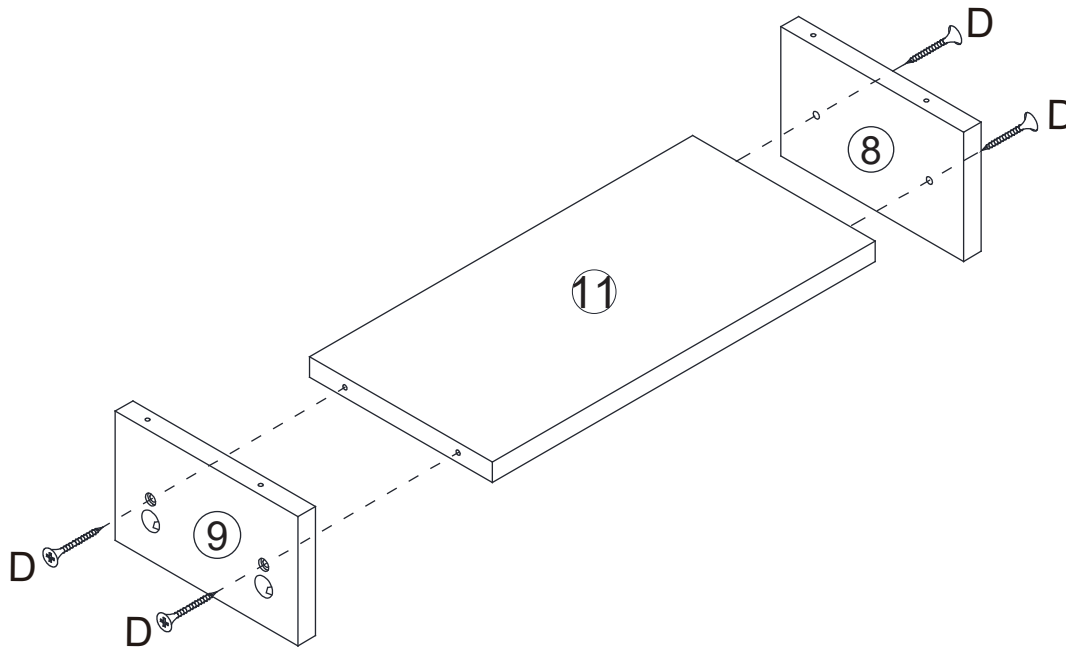

- Position Hutch Right Divide Panel (9) and Hutch Left Divide Panel (8) at end end of Hutch Shelf Panel (11) as shown.
- Align the screw holes on (11) with the screw holes on (8) & (9).
- Use screw (D) to fasten (8) & (9) to (11).

STEP 6

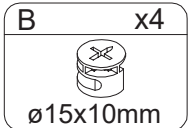
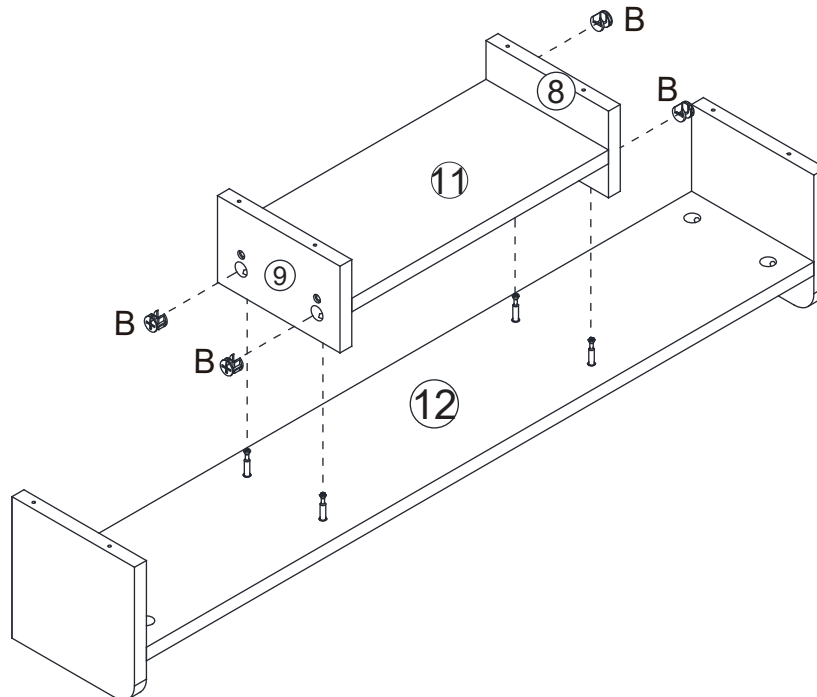

- Attach Hutch Shelf assembly from STEP 5 Hutch to Top Panel (12) from STEP 4 via Cam-bolt on (12).
- Insert Cam-lock (B) into the designated holes on Hutch Right Divide Panel (9) and Hutch Left Divide Panel (8). Use a Flat Screwdriver to turn (B) clockwise to lock onto Cam-bolts.

ASSEMBLY INSTRUCTIONS

DESK WITH HUTCH

STEP 7

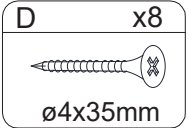
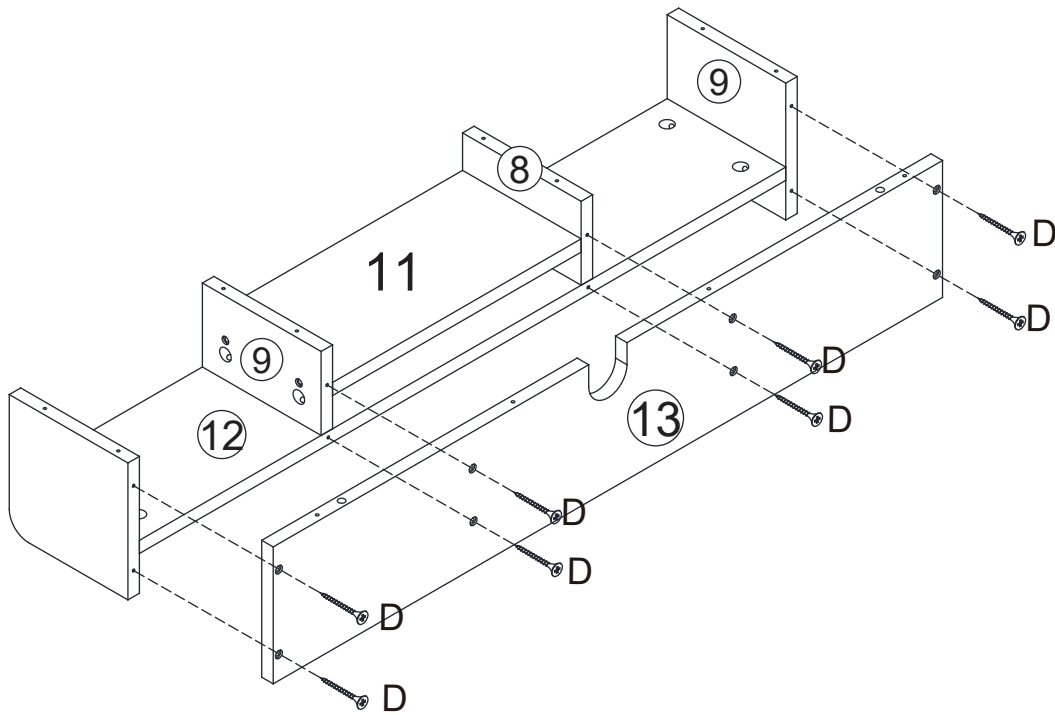

a) Use Screw (D) to fasten Hutch Back Panel (13) to the assembly in STEP 6 as shown. Note the orientation of (13).

STEP 8

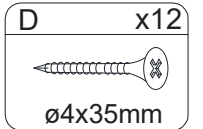
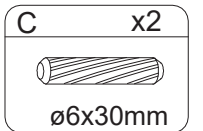
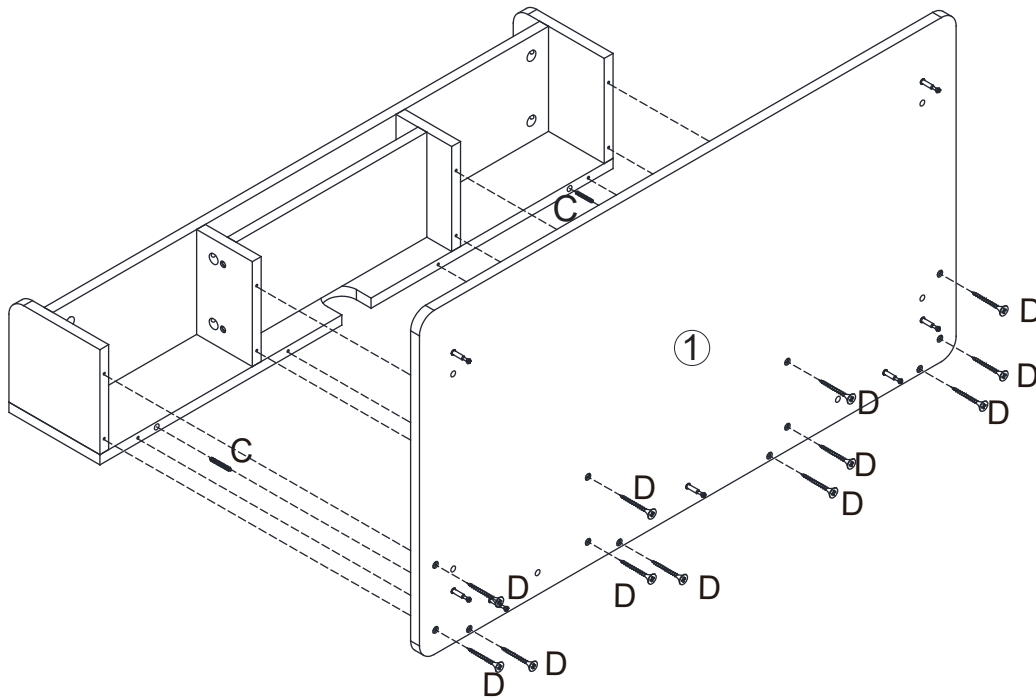





- a) Insert Wood Dowel (C) into the designated holes on Hutch Back Panel (13) on the assembly from STEP 7 as shown.
b) With assistance, attach Desk Top Panel (1) to assembly from STEP 7 via wood dowel on Hutch Back Panel (13) and fasten with Screw (D).

ASSEMBLY INSTRUCTIONS

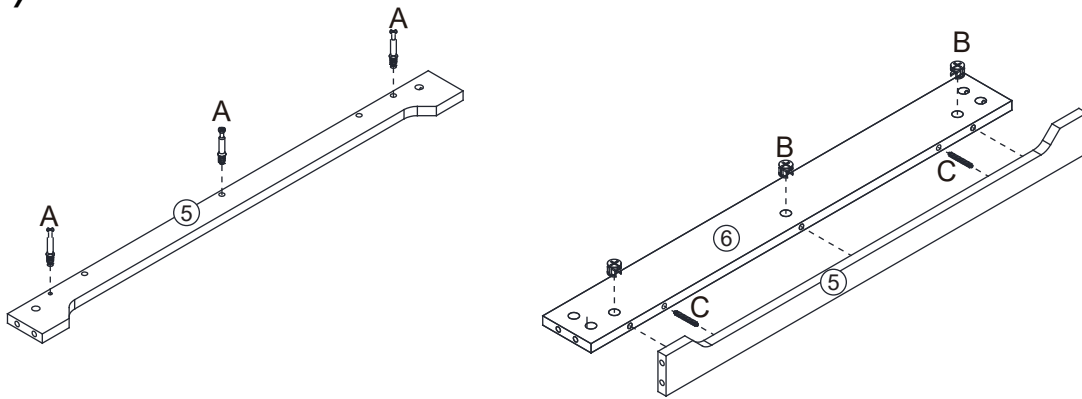
DESK WITH HUTCH

STEP 9





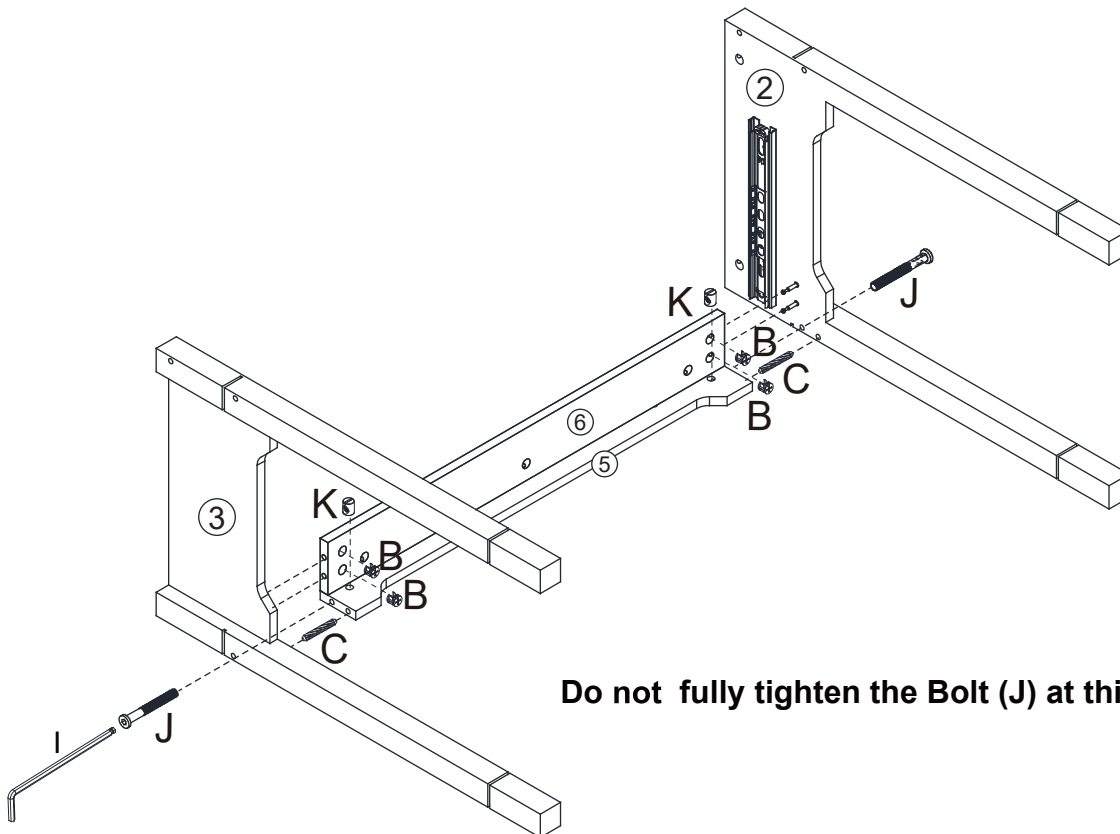

A	x3
	
ø6x35mm	
B	x3
	
ø15x10mm	
C	x2
	
ø6x30mm	

- a) Place the Front Support Rail (5) as shown on a material that does not scratch or damage the parts.
- b) Screw in Cam-bolt (A) into the designated holes on (5).
- c) Insert Wood Dowel (C) into the designated holes on Bottom Support Rail (6).
- d) Attach (5) to (6) via wood dowel and cam-lock on each part.
- e) Insert Cam-lock (B) into the designated holes on (6) and use a Flat Screwdriver to turn (B) clockwise to lock onto Cam-bolts.

STEP 10



B	x4
	
ø15x10mm	
C	x2
	
ø6x30mm	
J	x2
	
ø6x70mm	
K	x2
	
I	x1
	

Do not fully tighten the Bolt (J) at this time.



- a) Position the parts as shown on a material that does not scratch or damage the parts. Note the orientation of each part.
- b) Insert Wood Dowel (C) into the designated holes on Front Support Rail (5) from STEP 9 as shown.
- c) Attach Left and Right Frame (2 & 3) to the assembly from STEP 9 vis cam-bolt and wood dowel on each part.
- d) Insert Cam-lock (B) into the designated holes on Bottom Support Rail (6) and use a Flat Screwdriver to turn (B) clockwise to lock onto Cam-bolts.
- e) Use Bolt (J) to fasten (2 & 3) to Front Support Rail (5). Do not tighten (J) fully at this time. Use Allen Key (I) to drive (J).

ASSEMBLY INSTRUCTIONS

DESK WITH HUTCH

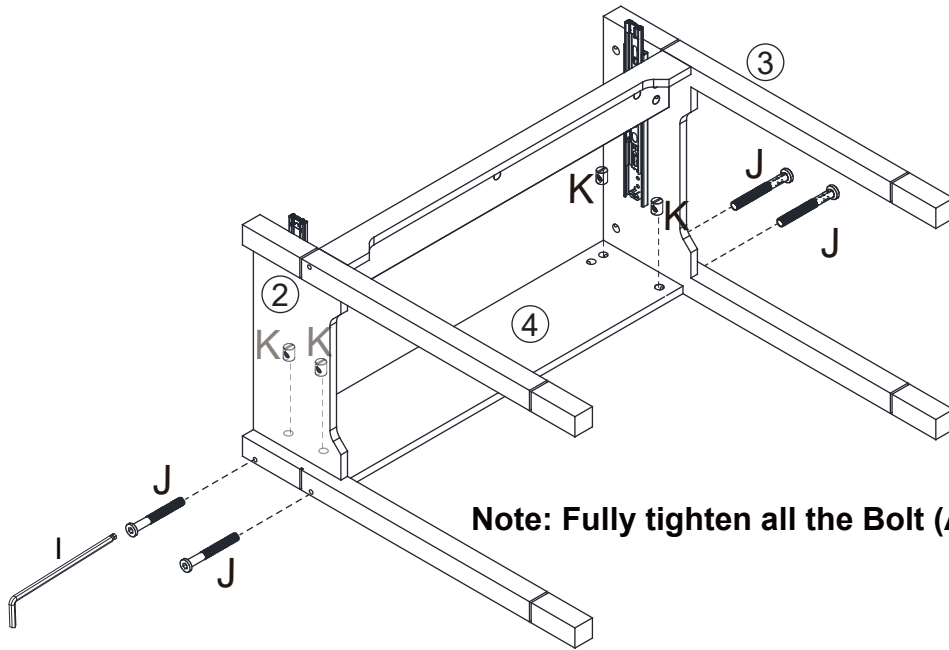
STEP 11





J	x4
	ø6x70mm
K	x4
	
I	x1
	

Note: Fully tighten all the Bolt (A) at the end of this time.

a) Fit Back Panel (4) between the Left and Right Frame as shown and fasten with Bolt (J). Use Allen Key (I) to drive (J).

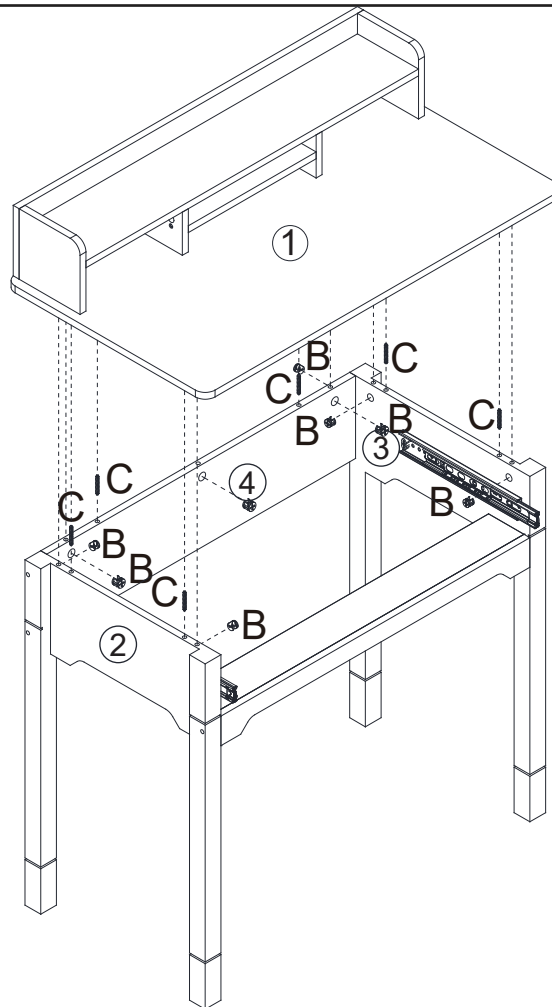
STEP 12

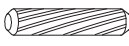

B	x7
	ø15x10mm
C	x6
	ø6x30mm

- With assistance set the assembly from STEP 11 right-side up and insert Wood Dowel (C) into the designated holes on the top edge of Left Frame, Right Frame and Back Panel.
- Attach Desk Top Panel assembly as shown via cam-bolt and wood dowels on each part. Insert Cam-lock (B) into the designated holes on (2, 3 & 4) and use a Flat Screwdriver to turn (B) clockwise to lock onto Cam-bolts.

ASSEMBLY INSTRUCTIONS

DESK WITH HUTCH

STEP 13

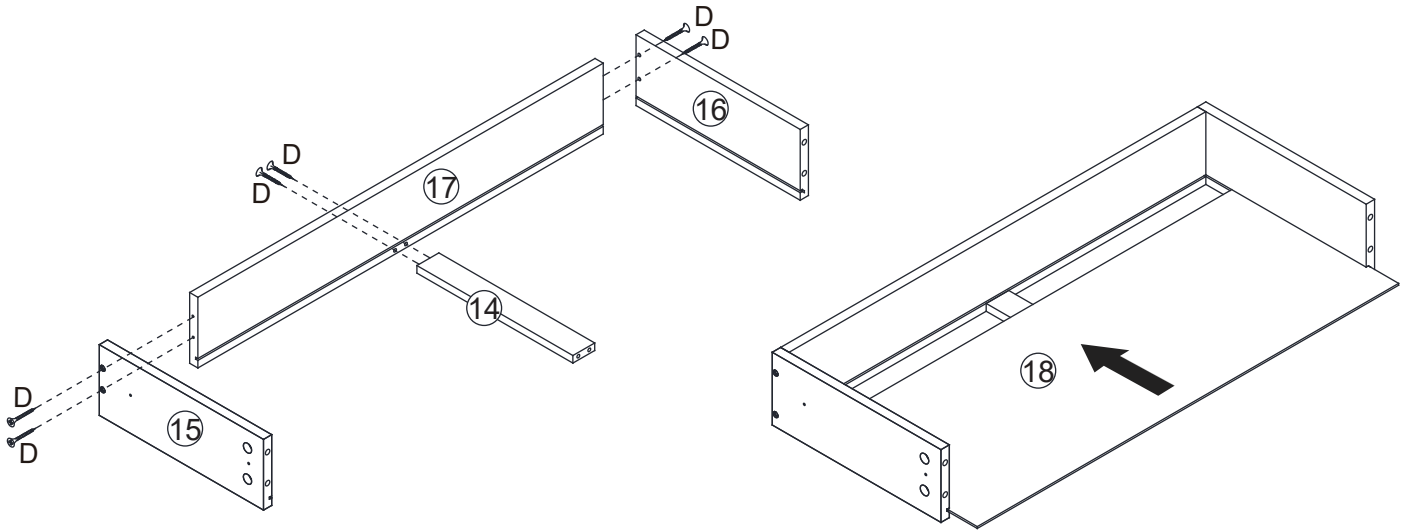
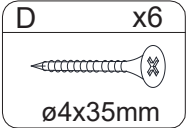

- Position Drawer Left Panel, Back Panel and Right Panel (15, 17 and 16) as shown - note the alignment of the groove on the panels - and fasten (15 & 16) to (17) with Screw (D).
- Use Screw (D) to fasten Drawer Bottom Support Rail (14) to (17).
- Fit Drawer Bottom Panel (18) via groove on (15 & 16). Check that the front edge of (18) fits into the groove on (17).

STEP 14

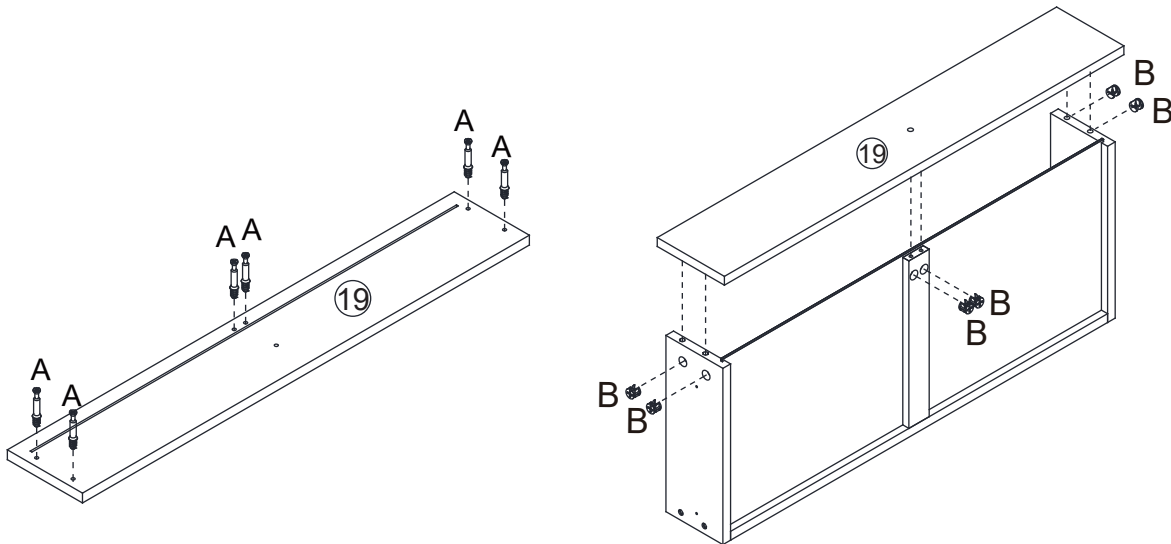
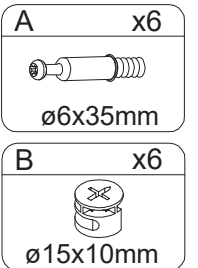





- Place Drawer Front Panel (19) as shown on a material that does not scratch or damage the part and screw in Cam-bolt (A) into the designated holes on (19).
- Attach (19) to Left and Right Panel of drawer assembly from STEP 13. Check that the top edge of the Bottom Panel fits into groove on the interior face of (19).
- Insert Cam-lock (B) into the designated holes on Drawer Left and Right Panel and use a Flat Screwdriver to turn (B) clockwise to lock onto Cam-bolts.

ASSEMBLY INSTRUCTIONS

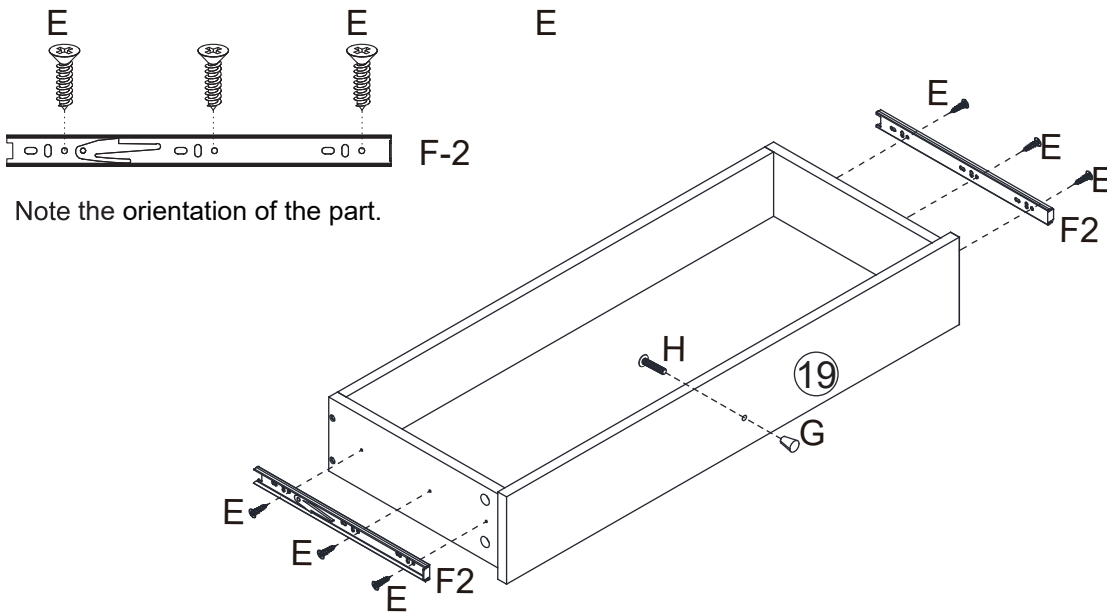
DESK WITH HUTCH

STEP 15





E	x6
	ø3x12mm
F2	x2
	
H	x1
	
G	x1
	ø4x18mm

- a) Place drawer assembly from STEP 15 as shown on a material that does not scratch or damage the parts.
- b) Fasten Slide Runner (F2) to Drawer Side Panel with Screw (E).
- c) Use Handle Bolt (H) to fasten Knob (G) to Drawer Front Panel (19).

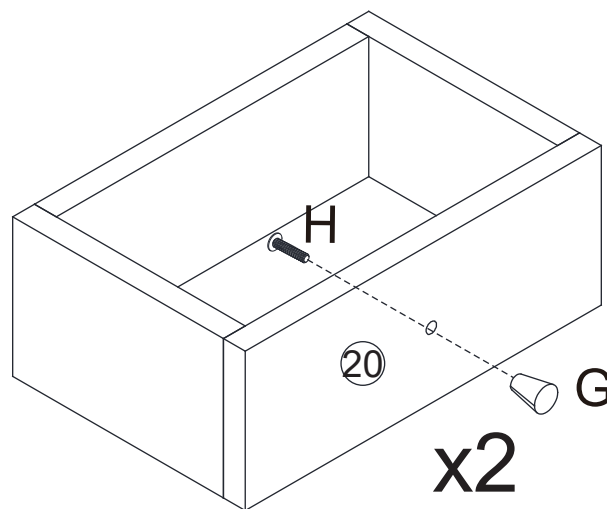
STEP 16



H	x2
	
G	x2
	ø4x18mm

- a) Use Handle Bolt (H) to fasten Knob (G) to Hutch Drawer (20).

ASSEMBLY INSTRUCTIONS

DESK WITH HUTCH

STEP 17

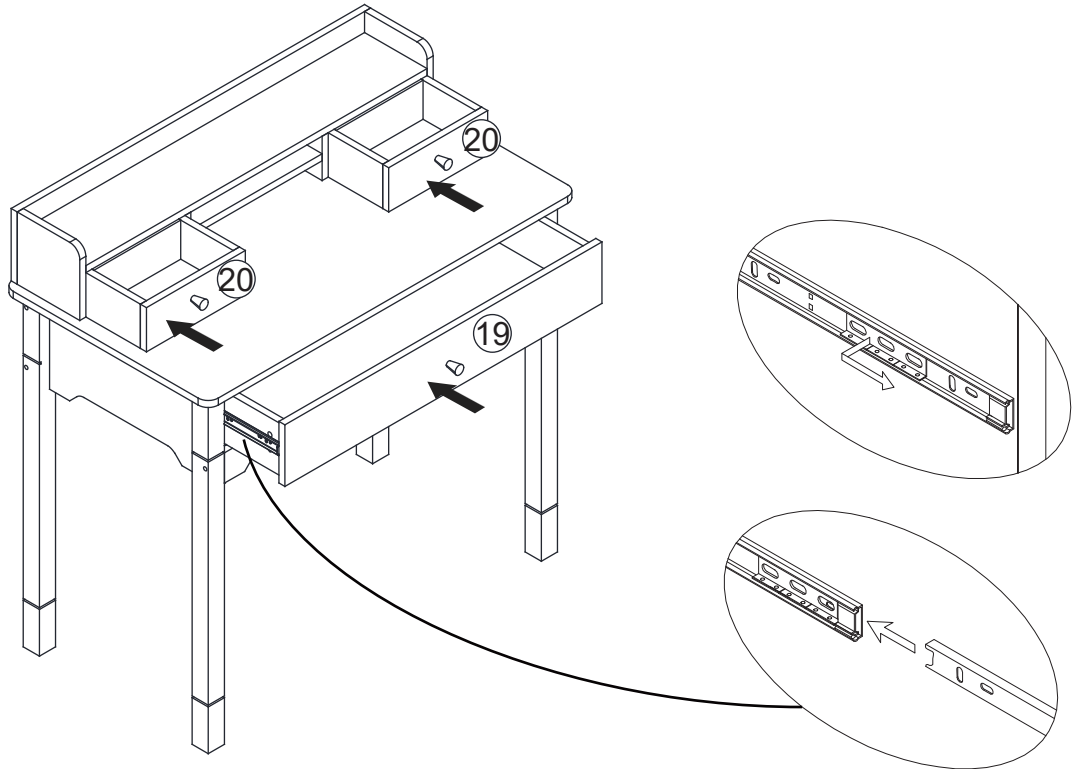

Insert Drawer:

- On the Left and Right Drawer Panel of the desk, bring the ball-bearing slider on Slide Track (F1) forward to the front edge of (F1) (towards drawer opening of the desk).
- On the Left & Right Panel of the Drawer, bring the ball-bearing slider (metal chrome plate) on Slide Track (F2) forward towards drawer opening of the desk to the front edge of (F2).
- Align the back open-end of the Slide Runner (F2) on each side of the drawer to fit squarely into the groove on the open front-end of (F1) on the Left and Right Panel. Be sure the drawer/(F2) is not tilted or angled, and push in drawer squarely.
- When the drawer is pushed in about half way, the Trigger Disconnect Lever on (F2) will be engaged onto (F1) which will create a slight resistance - this is normal. Pull out the drawer a little bit and gently push in the drawer again to engage the Trigger Disconnect Lever to the slide mechanism on (F1). The drawer should now slide smoothly.
- If the drawer cannot be pushed in or stuck, do not force it in. Remove the drawer and repeat the steps above.

ASSEMBLY INSTRUCTIONS

DESK WITH HUTCH

STEP 18

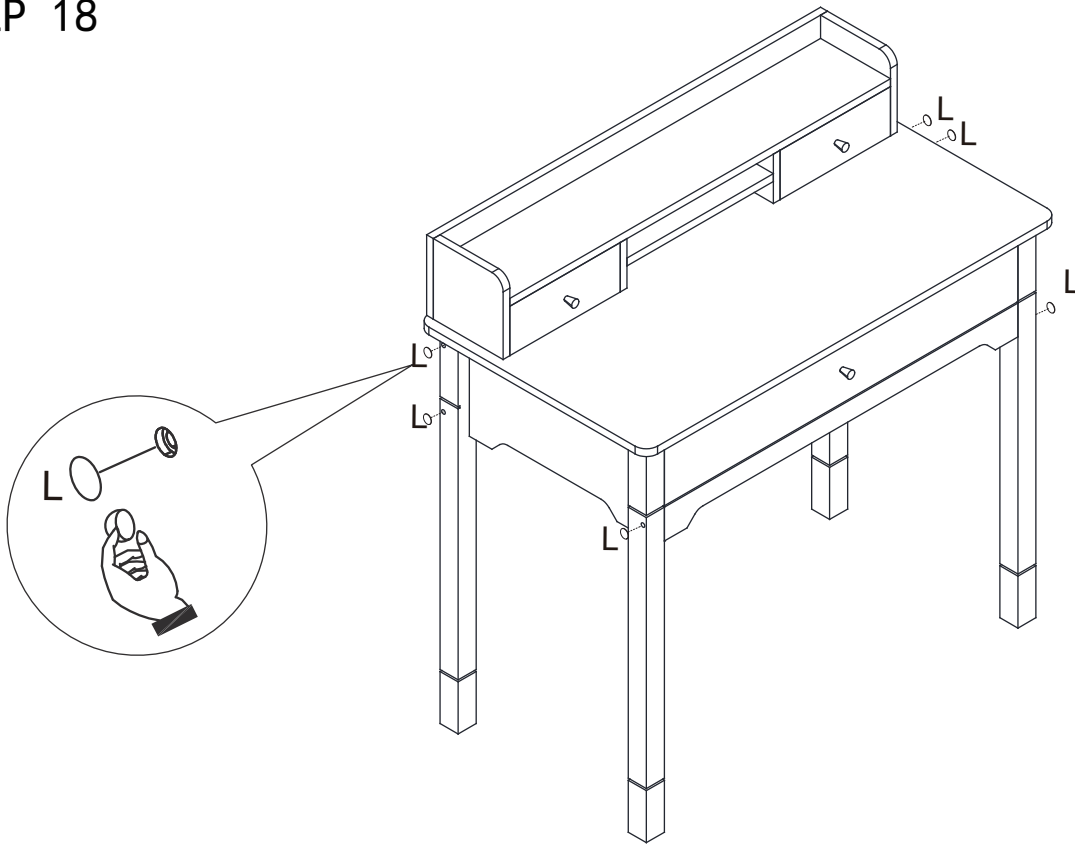
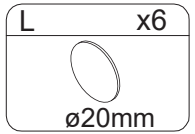

a) Use Sticker (L) to conceal on visible screw holes on the Left and Right Frame as shown

The assembly of the Desk is complete.