

# Assembly Instructions

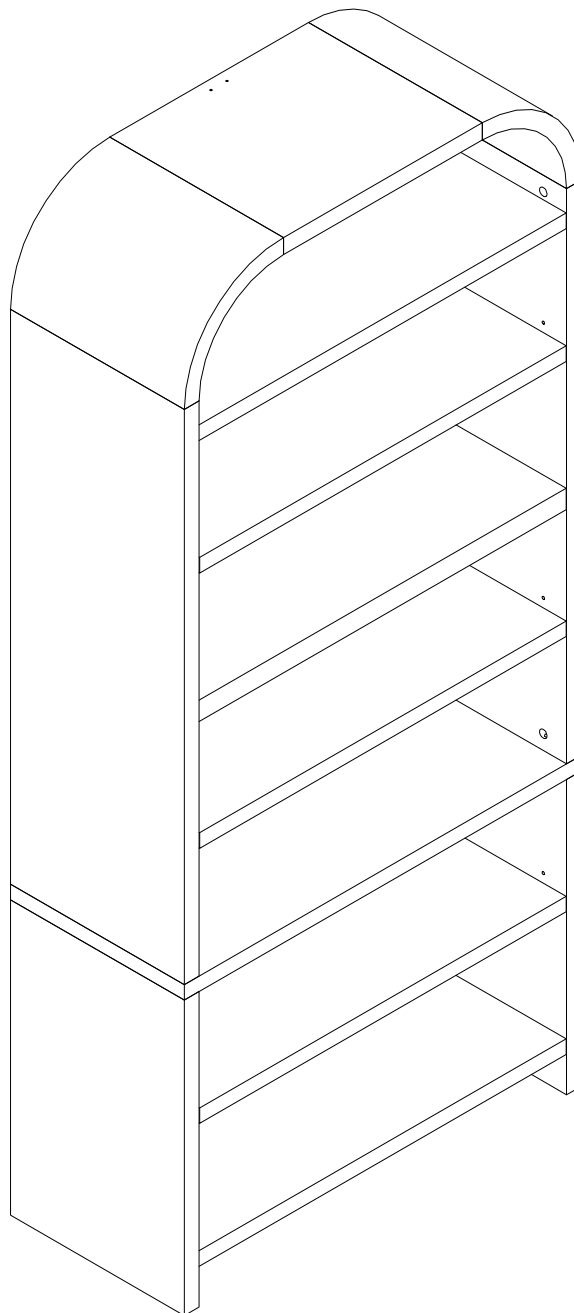

# Before Assembly

## Tips Before Your Start:

- Remove all wrapping material, including staples & packing straps before you start to assemble.
- DO NOT tighten all screws and bolts until the assembly is completely assembled.
- Keep all hardware parts out of reach of children.

## QUICKFIT

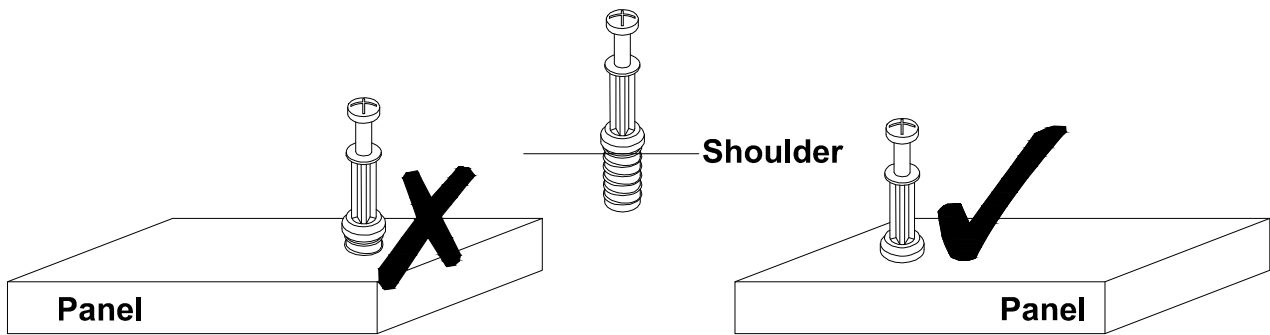

Tighten quickfit until shoulder is flush with panel. Do not overtighten or undertighten.

## CAM LOCK

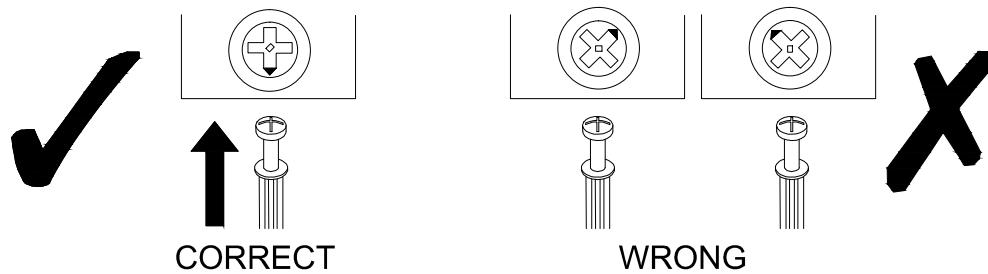

When fitting a cam lock, ensure the starting position is correct before inserting the connecting QUI CKFIT





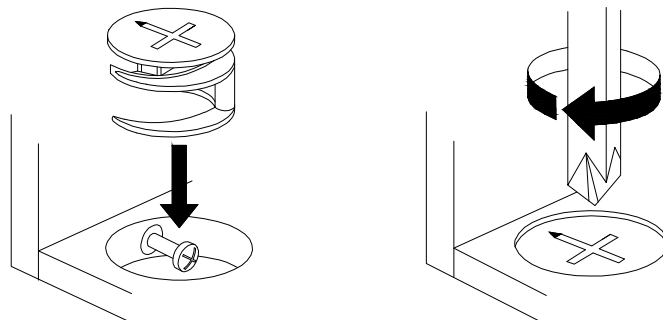

Quickfit head should be in the centre of the cam lock when the two panels are joined.

Cam lock should be inserted before quickfit.

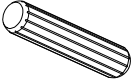
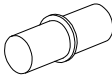

Turn cam lock clockwise to tighten.

# Part List

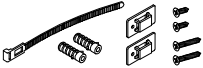
<p><b>No. A</b> Quantity: 28 Pcs Cam Lock Dowel 8*28mm</p> 	<p><b>No. B</b> Quantity: 28 Pcs Cam φ15</p> 	<p><b>No. C</b> Quantity: 28 Pcs Sticker Ø20</p> 	<p><b>No. D</b> Quantity: 14 Pcs Dowel 8*30mm</p> 
<p><b>No. E</b> Quantity: 12 Pcs Shelf Support M5*15mm</p> 	<p><b>No. F</b> Quantity: 1 Pcs Backboard spline 946*11*6mm</p> 	<p><b>No. G</b> Quantity: 1 Pcs Backboard spline 453*11*6mm</p> 	<p><b>No. H</b> Quantity: 14 Sets Plastic Wedge</p> 
<p><b>No. I</b> Quantity: 4 Pcs Foot Pad Ø15</p> 	<p><b>No. J</b> Quantity: 1 Sets Anti-falling Parts</p> 		

# Product structure

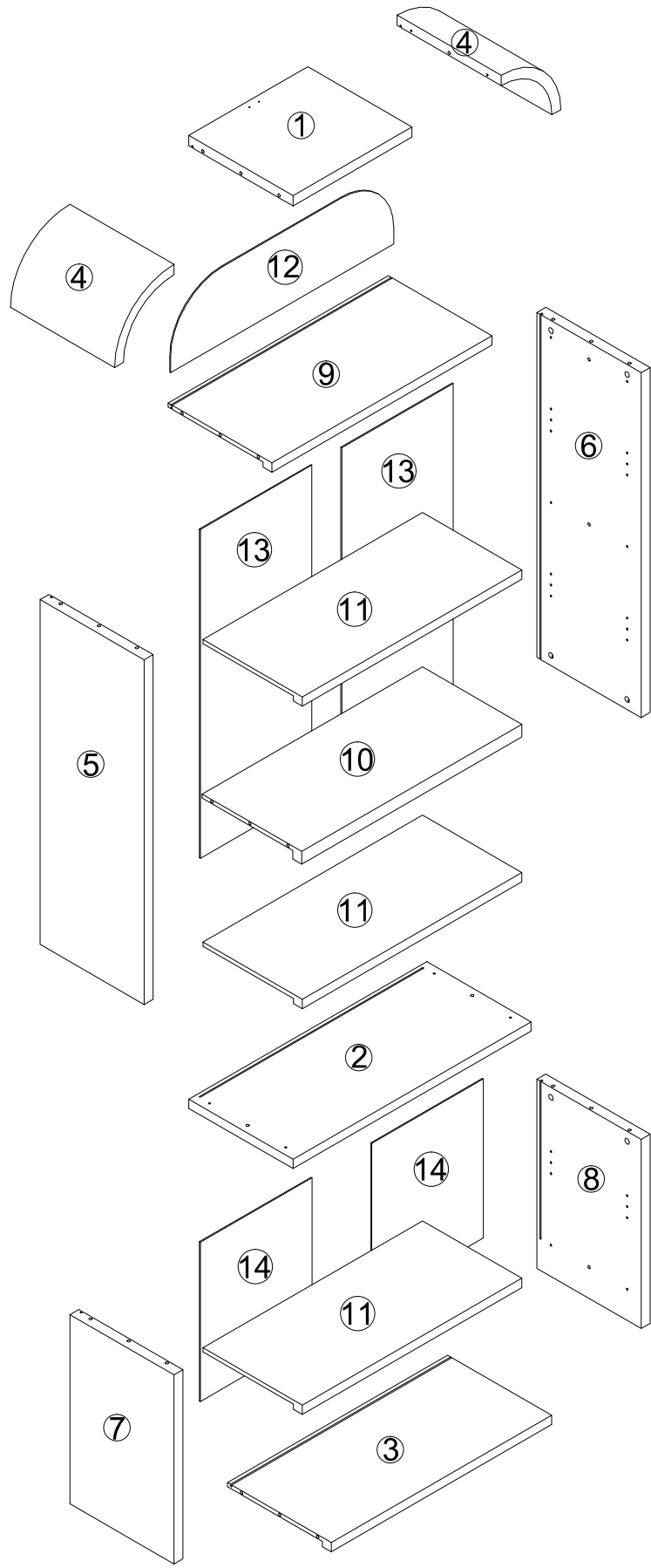

# STEP 1

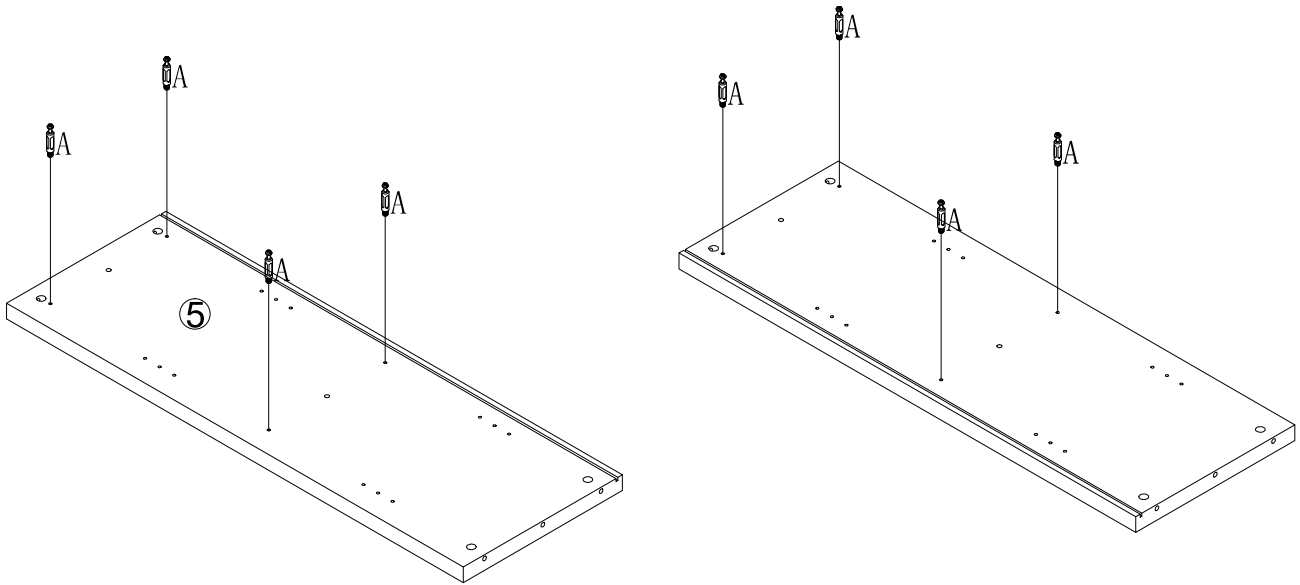

No. A  
Quantity: 8 Pcs  
8\*28 mm



# STEP 2

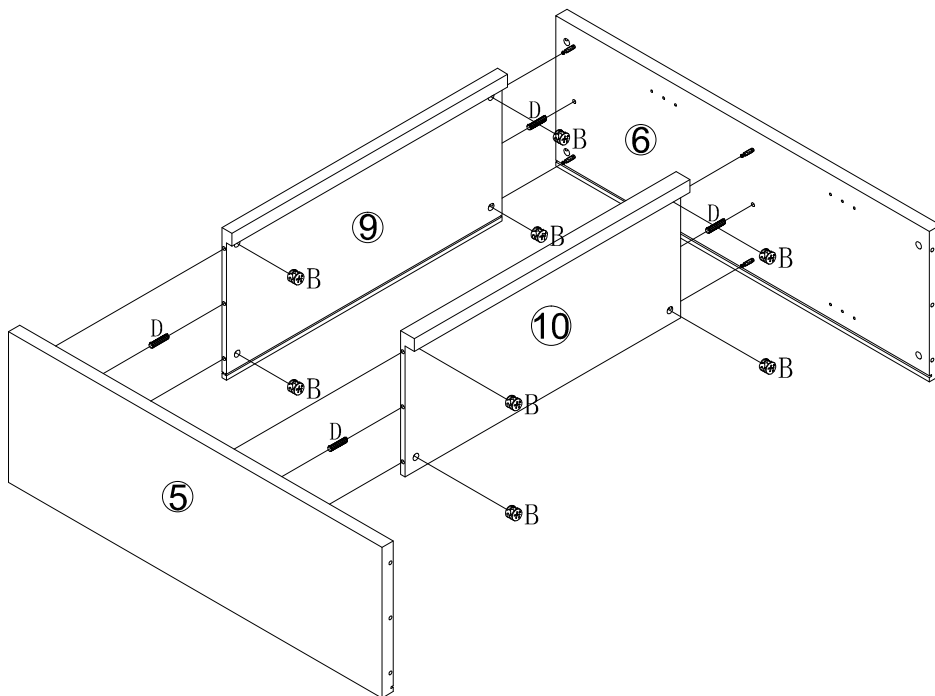

No. B  
Quantity: 8 Pcs  
Ø15



No. D  
Quantity: 4 Pcs  
8\*30mm



# STEP 3

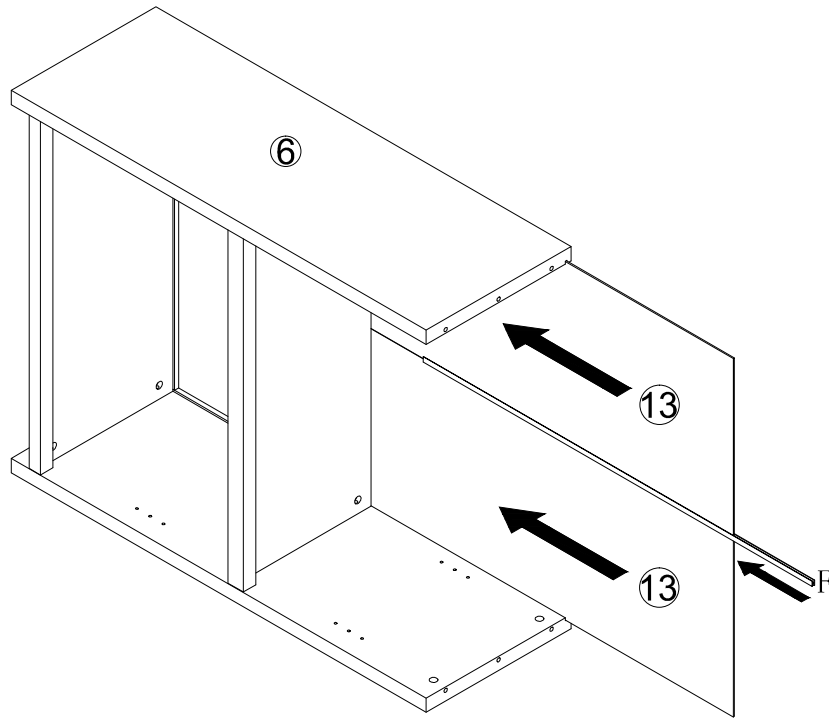

No. F  
Quantity: 1 Pcs  
946\*11\*6mm

# STEP 4

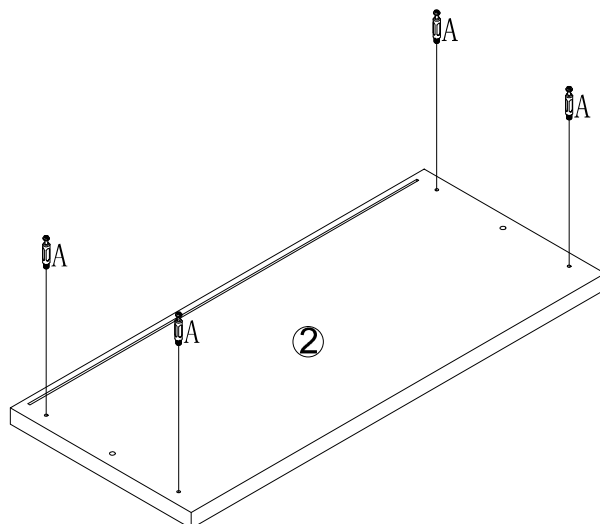

No. A  
Quantity: 4 Pcs  
8\*28 mm



# STEP 5

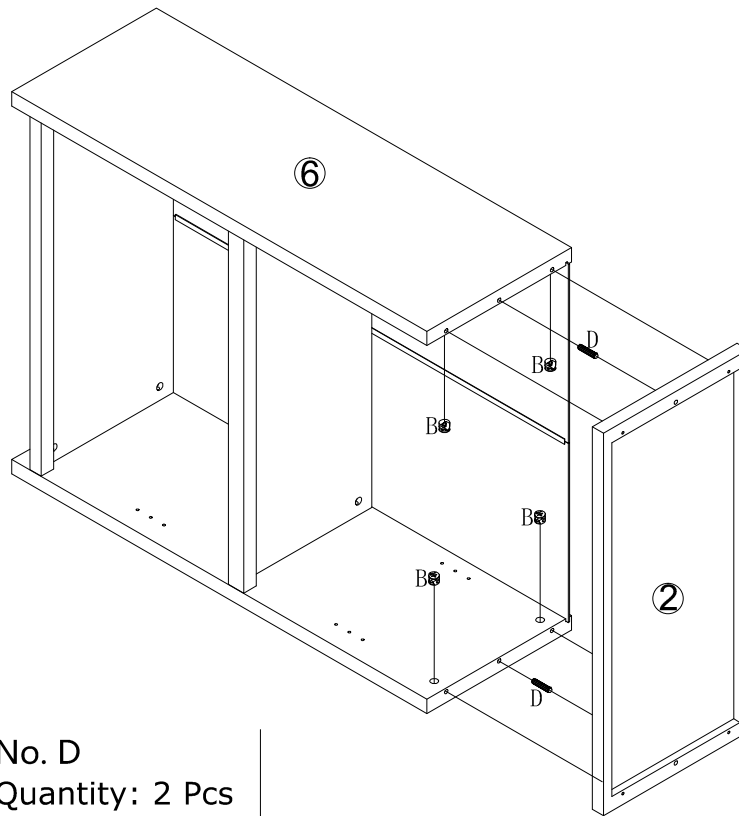

No. B  
Quantity: 4 Pcs  
Ø15



No. D  
Quantity: 2 Pcs  
8\*30mm



# STEP 6

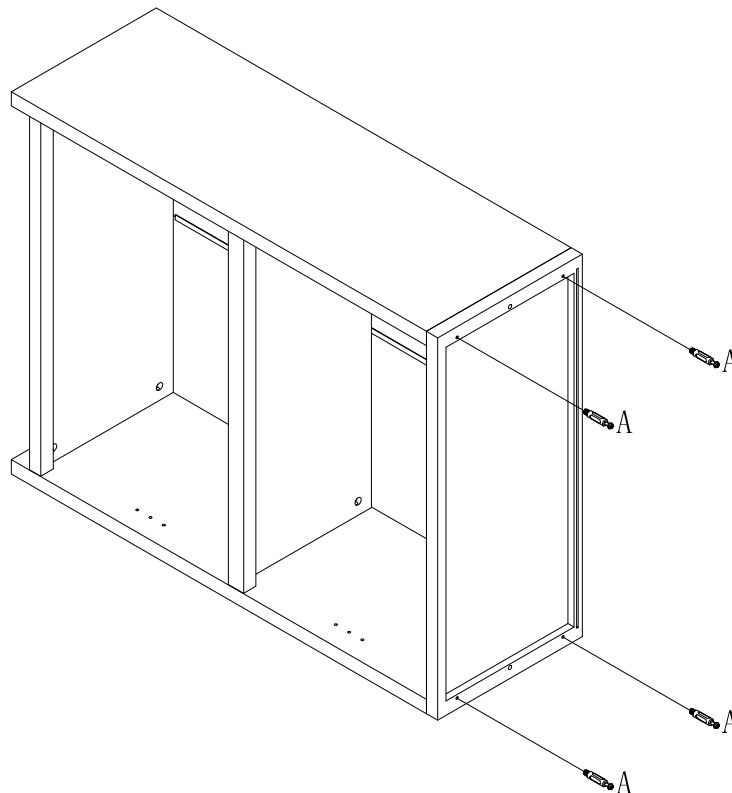

No. A  
Quantity: 4 Pcs  
8\*28 mm



# STEP 7

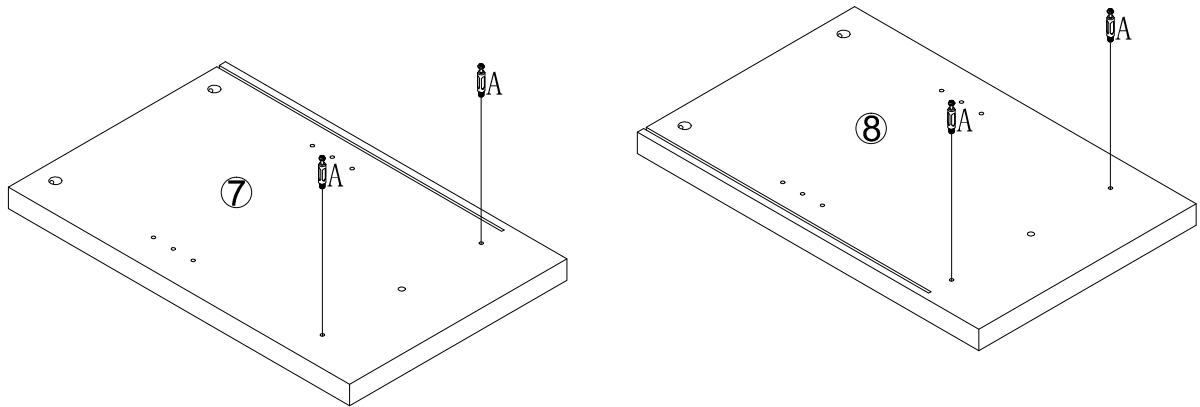

No. A  
Quantity: 4 Pcs  
8\*28 mm



# STEP 8

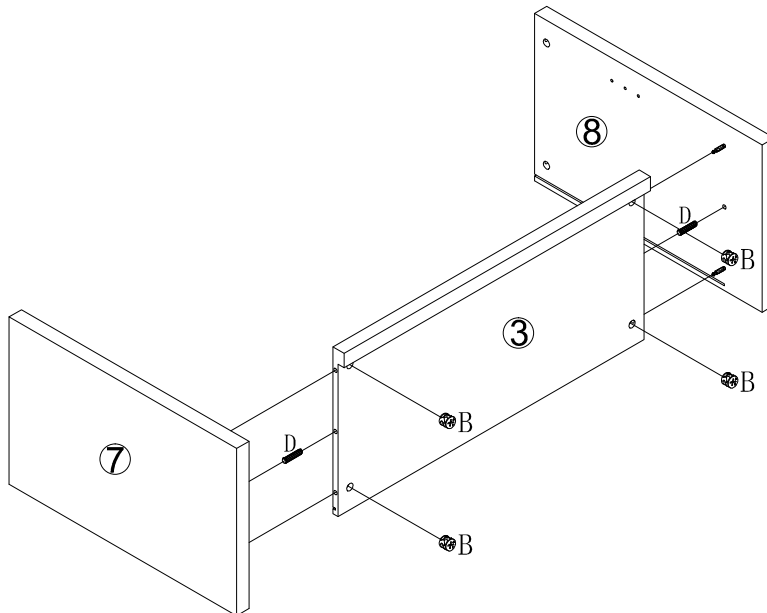

No. B  
Quantity: 4 Pcs  
Ø15



No. D  
Quantity: 2 Pcs  
8\*30mm



# STEP 9

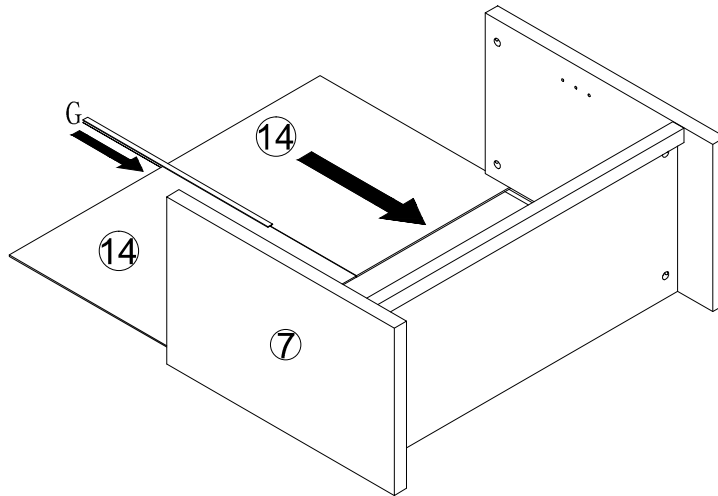

No. G  
Quantity: 1 Pcs  
453\*11\*6mm



# STEP 10

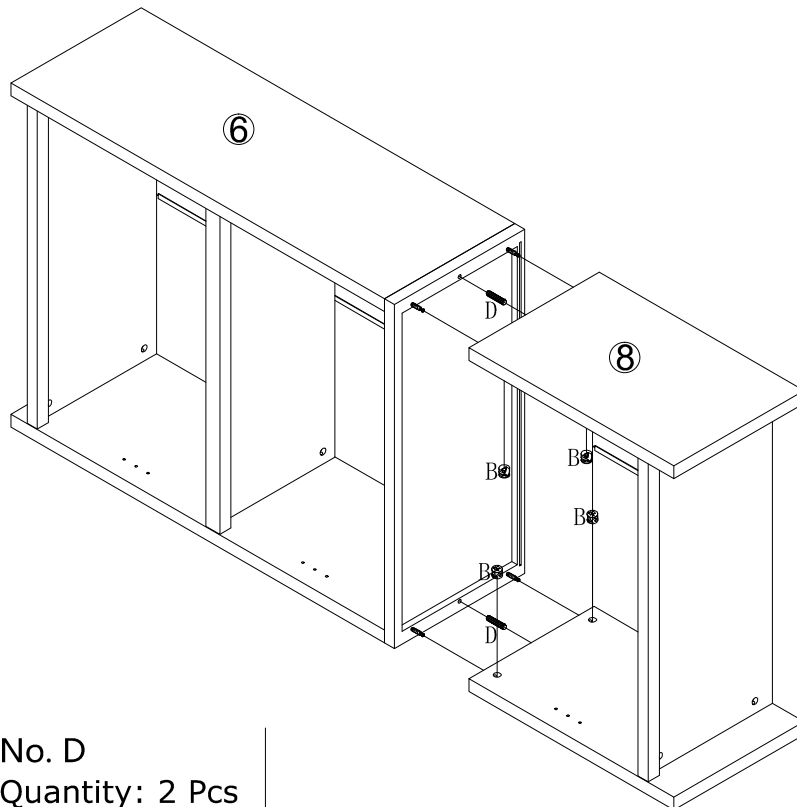

No. B  
Quantity: 4 Pcs  
Ø15



No. D  
Quantity: 2 Pcs  
8\*30mm



# STEP 11

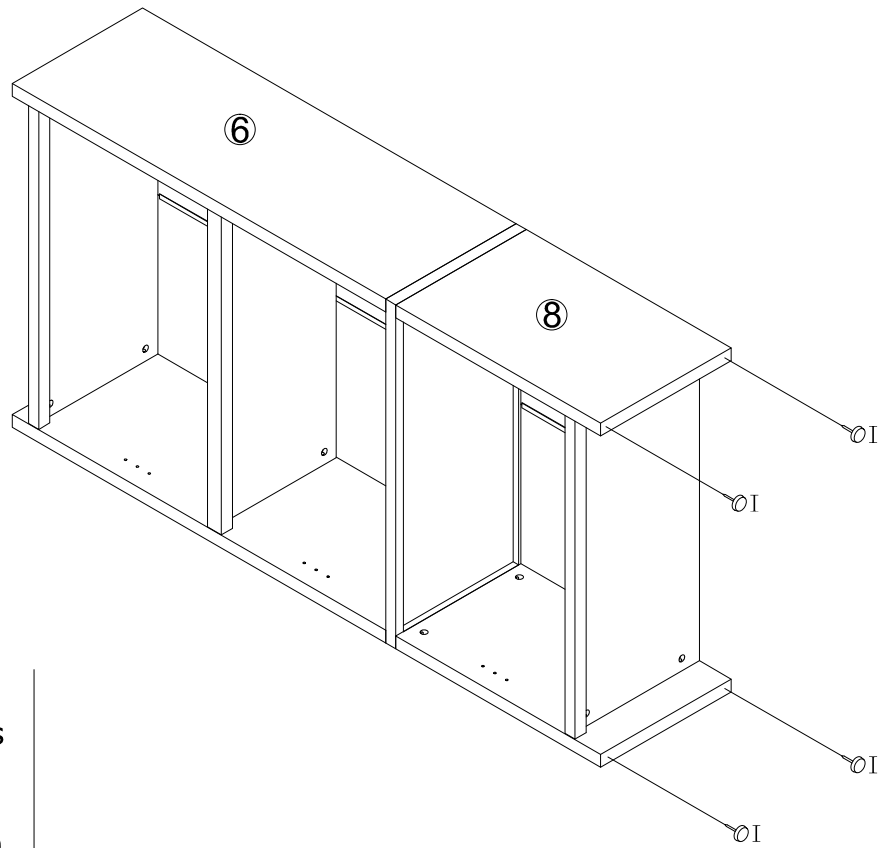

No. I  
Quantity: 4 Pcs  
Ø15



# STEP 12

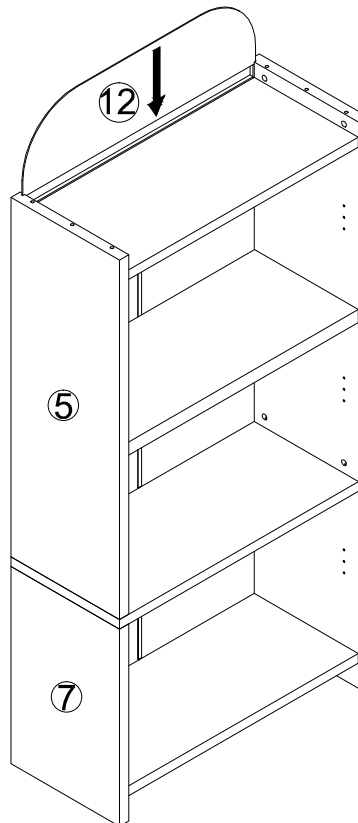

# STEP 13

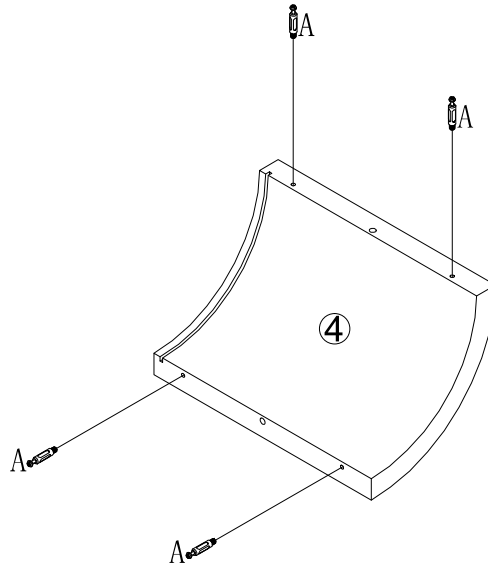

**x2**

No. A  
Quantity: 8 Pcs  
8\*28 mm



# STEP 14

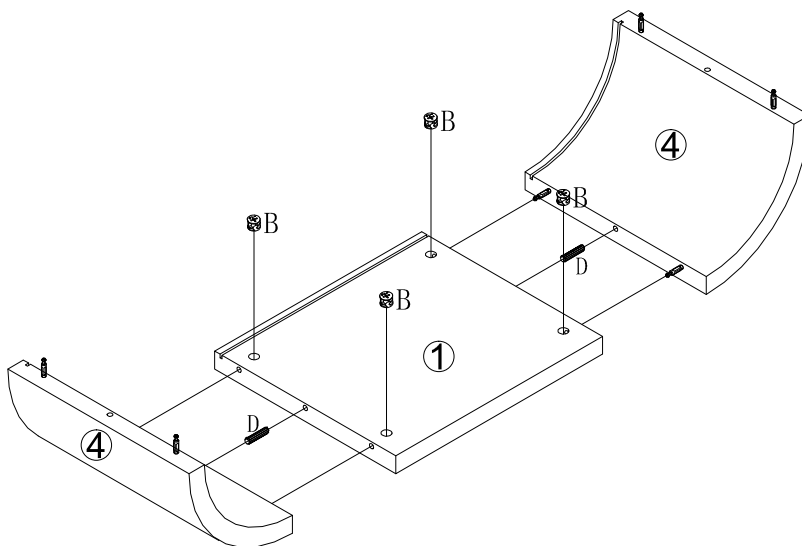

No. B  
Quantity: 4 Pcs  
Ø15



No. D  
Quantity: 2 Pcs  
8\*30mm



# STEP 15

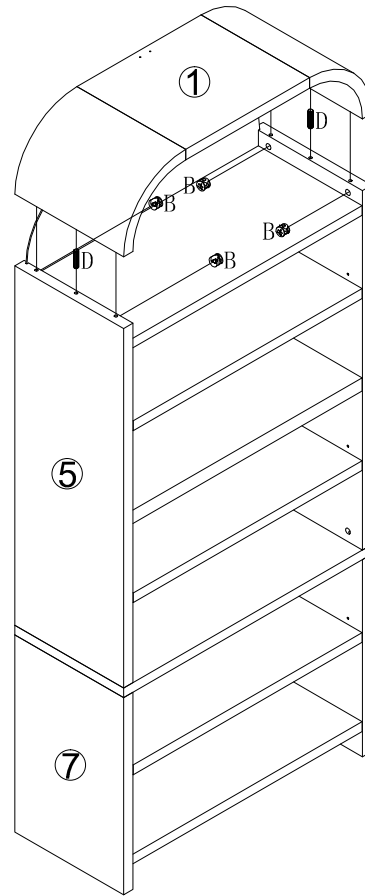

No. B  
Quantity: 4 Pcs  
Ø15



No. D  
Quantity: 2 Pcs  
8\*30mm



# STEP 16

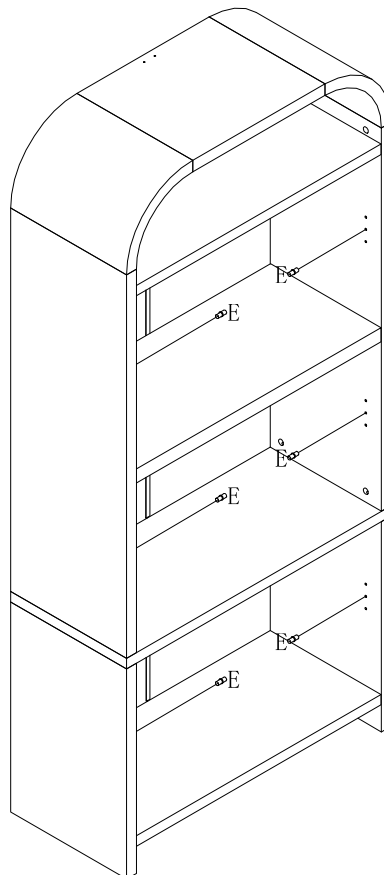

No. E  
Quantity: 12 Pcs  
M5\*15mm



## STEP 17

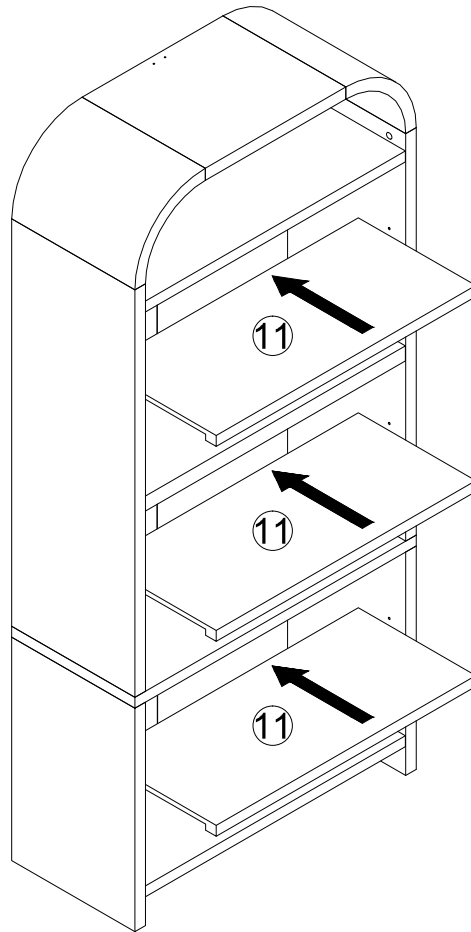

## STEP 18

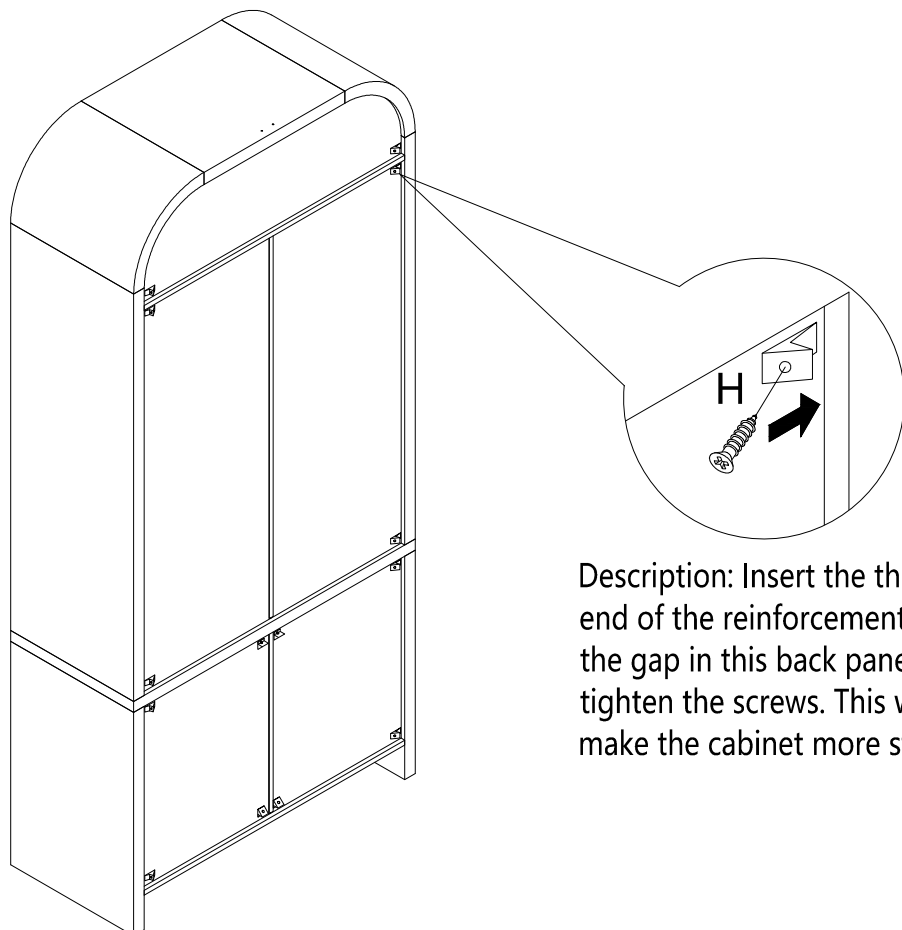

Description: Insert the thinner end of the reinforcement into the gap in this back panel, then tighten the screws. This will make the cabinet more stable.

No. H  
Quantity: 14 Sets

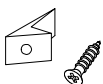

# STEP 19

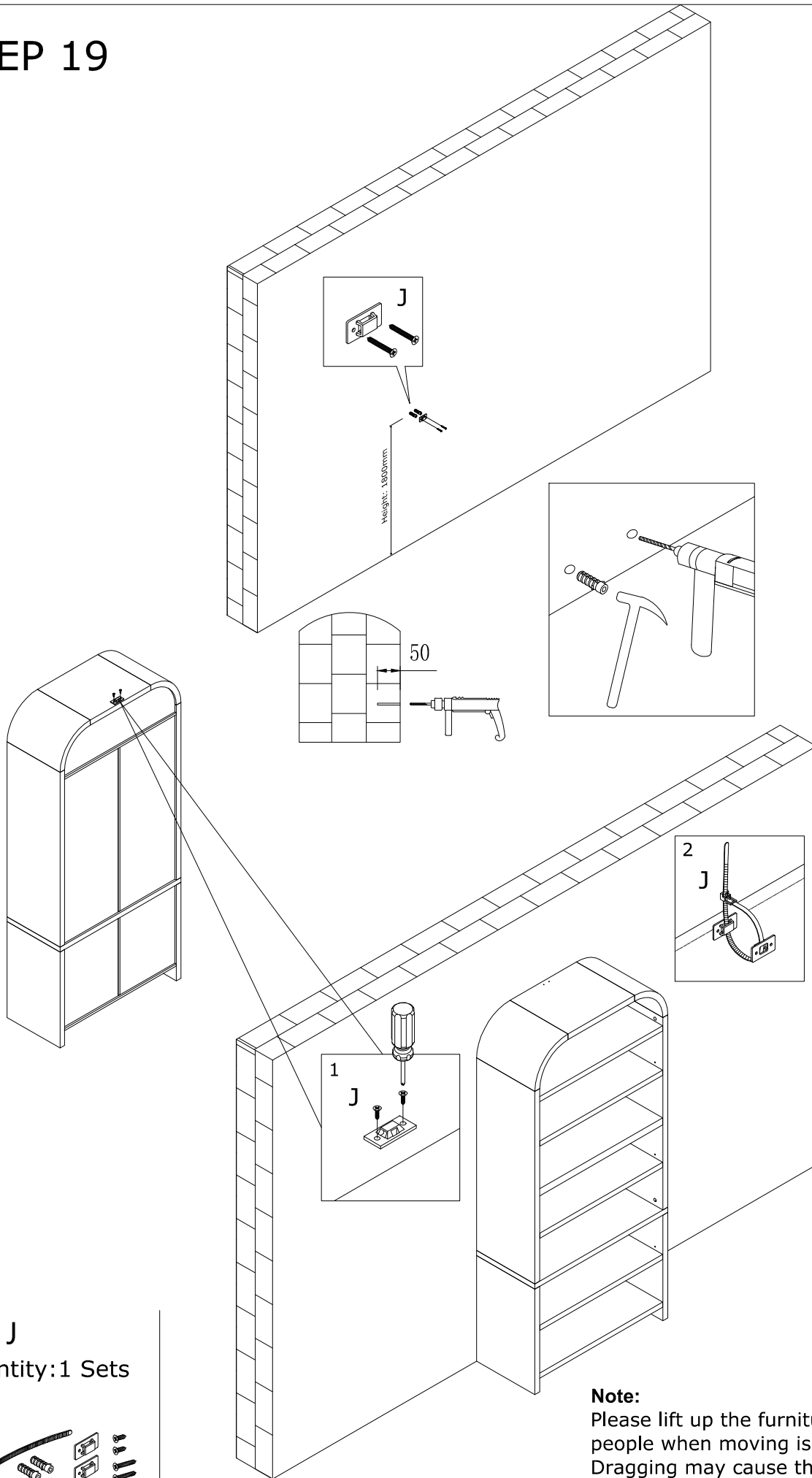

No. J  
Quantity: 1 Sets

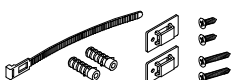

**Note:**  
Please lift up the furniture by two people when moving is needed.  
Dragging may cause the legs failure.