

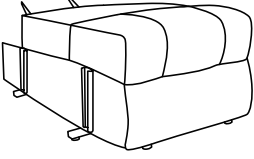

PARTS LIST

<p>A</p>  <p>Base x1</p>	<p>B</p>  <p>Backrest x1</p>	<p>C</p>  <p>Armrest x2</p>	<p>D</p>  <p>Lift Remote x1</p>	<p>E</p>  <p>Massage Remote x1</p>	<p>F</p>  <p>Power Adapter x1</p>	<p>H</p>  <p>Rack Circular Gasket x2 (Spare parts)</p>
		<p>G</p>  <p>Anti-back-tipping x2</p>			<p>I</p>  <p>Lumbar Pillow x1</p>	

STEP 1 Armrest Assembly

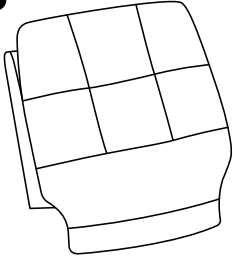
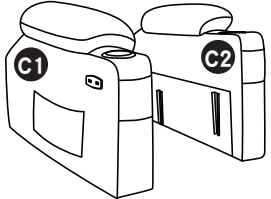
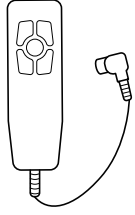
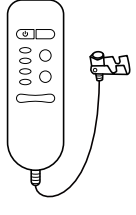
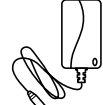
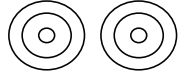

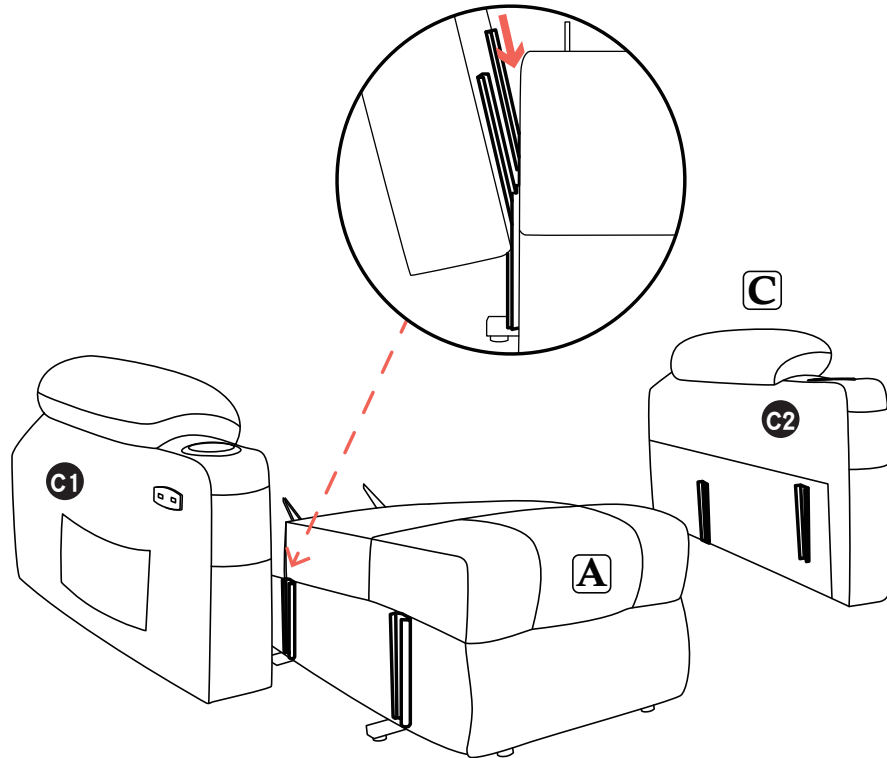
STEP 2 Backrest Assembly

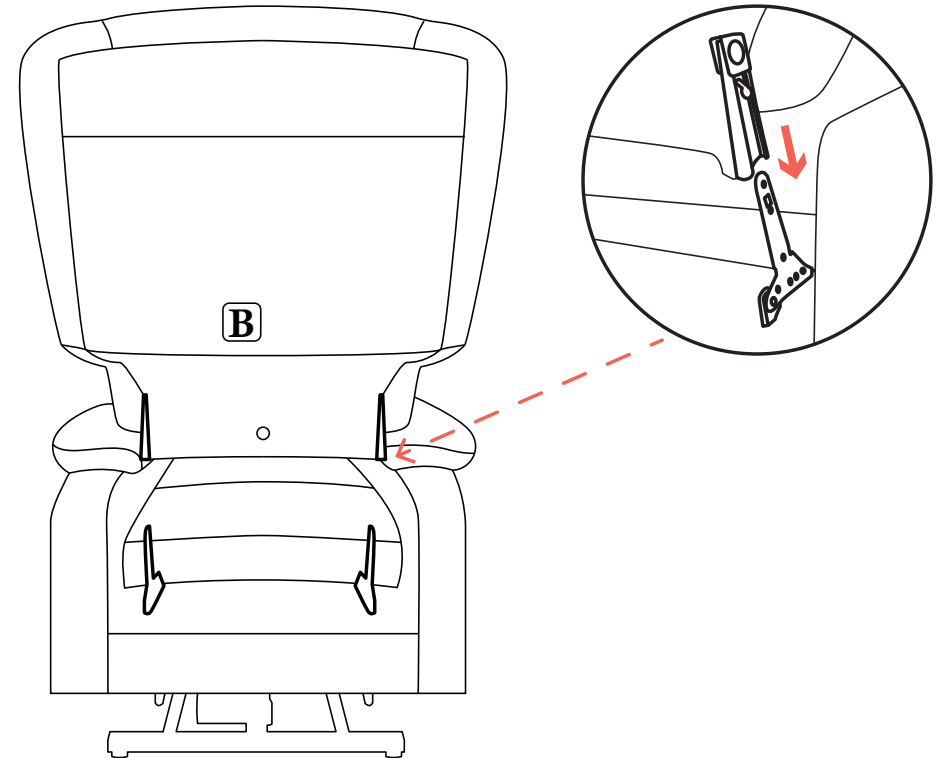

STEP 3

Lift Connections

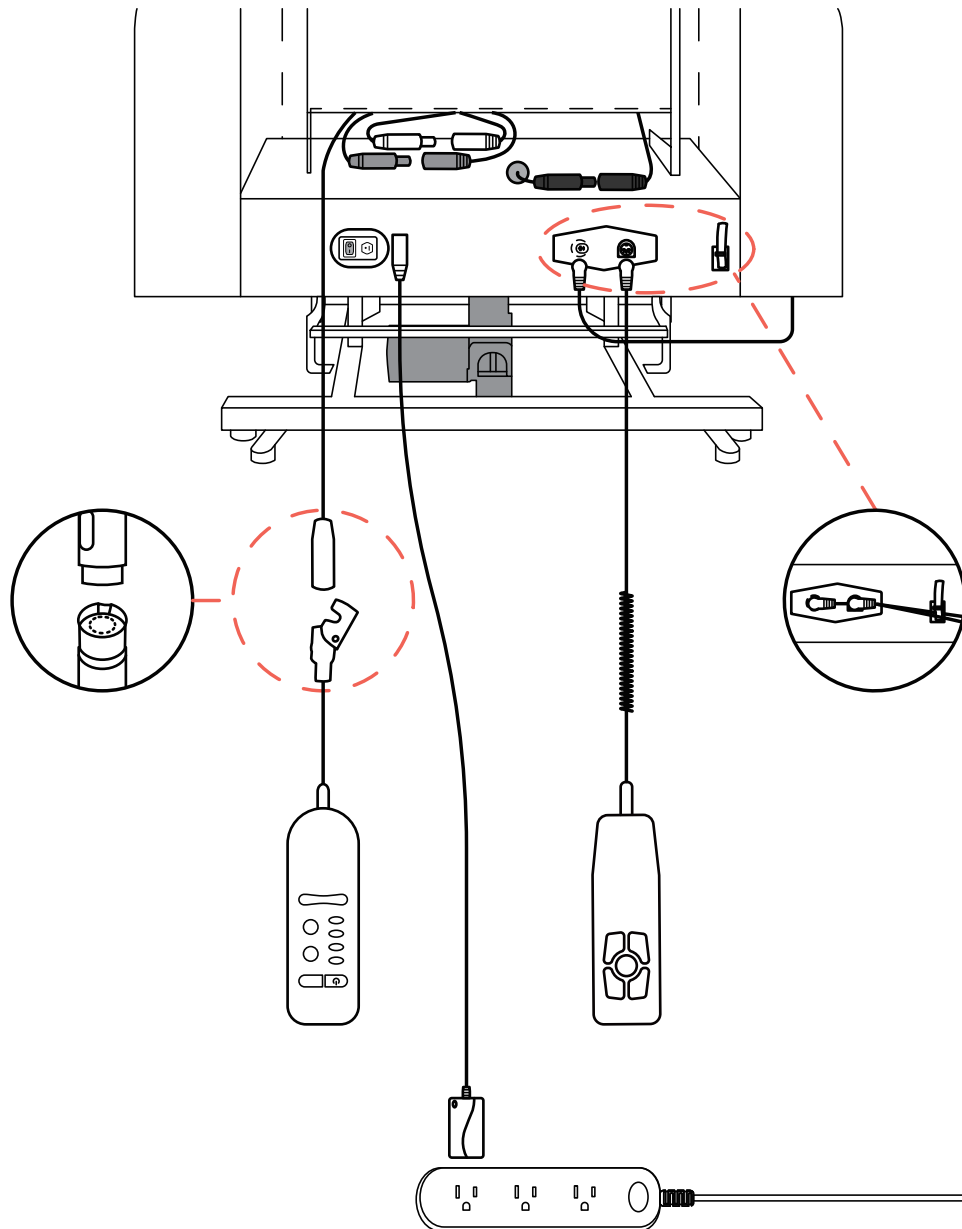

STEP 4

Anti-back-tipping Part Assembly

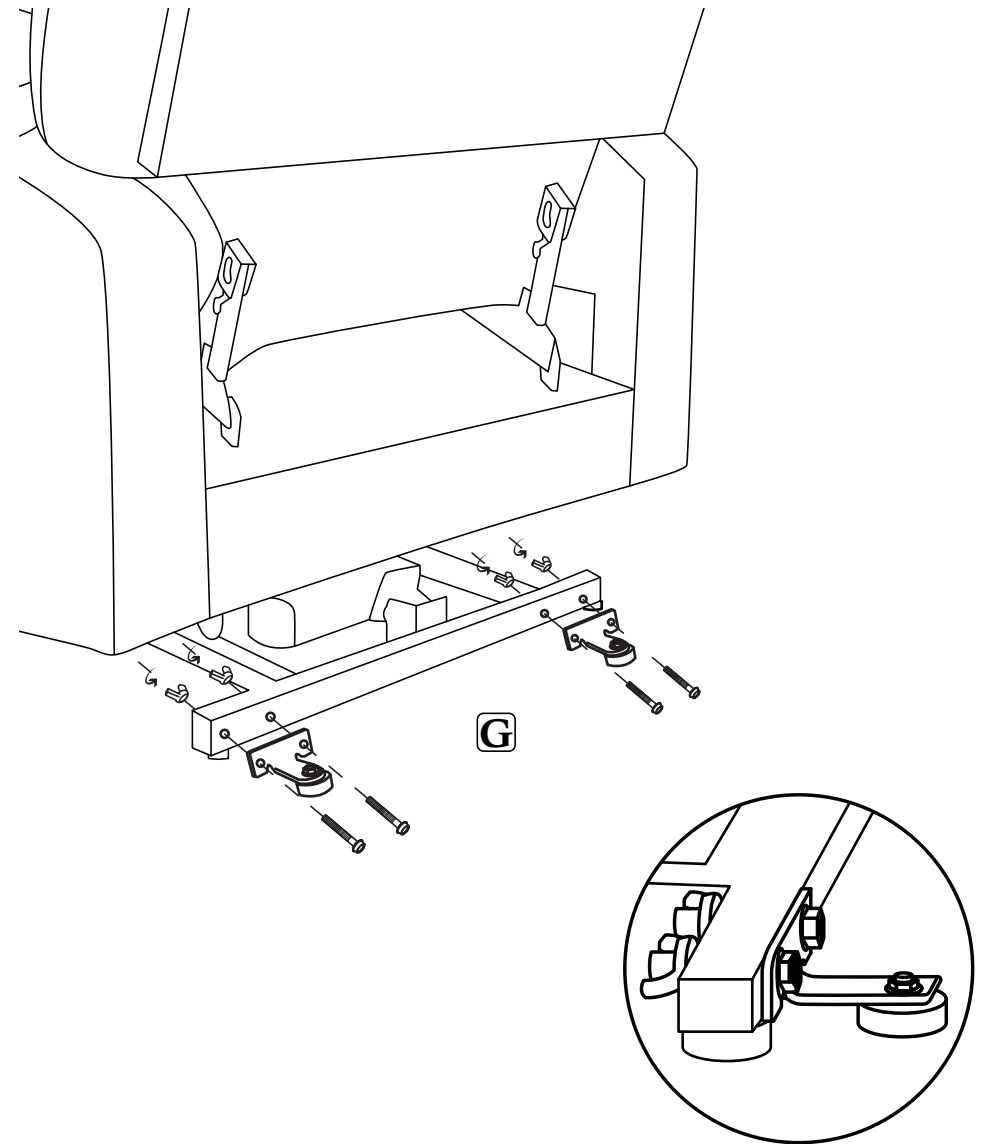

LIFT REMOTE OPERATION INSTRUCTION



Press to recline the backrest of the chair.



Press to raise the backrest of the chair.



Press to return the chair to Normal position from any position.

(The lift motor of the backrest will run for 3 seconds first, and then the lift motor of the base will run, to improve safety and sense of use during use.)



Press to raise the seat and return the extension footrest.



Press to recline the base and lift extension footrest brace.

NOTE: If you press the HOME button and the chair does not return to its normal position, you need to reset the HOME button.

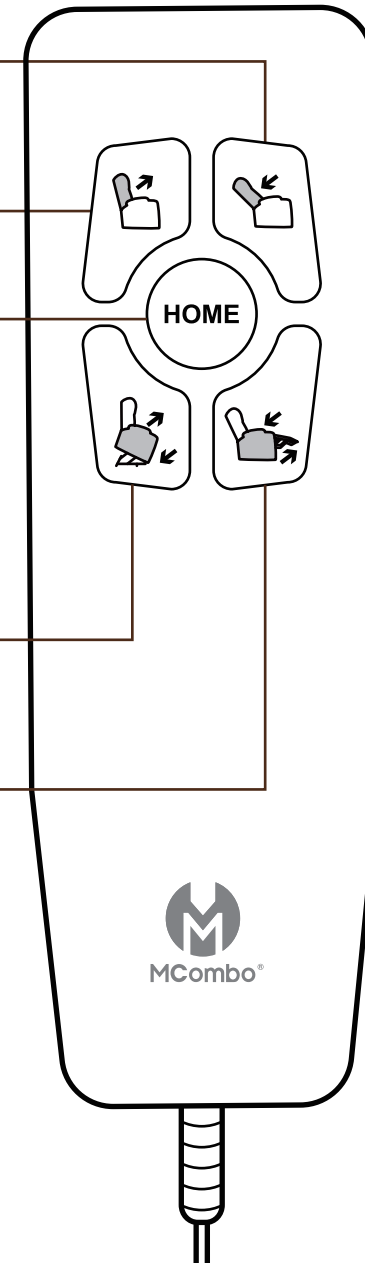

MASSAGE REMOTE OPERATION INSTRUCTION

- HEAT:** Turn on/off heat function
- POWER:** Turn on/off massage function
- MODE:** Press to select 3 different massage modes
- TIMER:** The timer can be set in fixed time 10 / 20 / 30 minutes
- INTENSITY:** Press to adjust massage intensity from low to high
- POINTS:** Control massage points (Back, Lumbar, Thigh, Leg)

NOTE: Use the heating only:
Turn off the POWER button, turn on the HEAT button.
(Heating function works with vibration separately.)

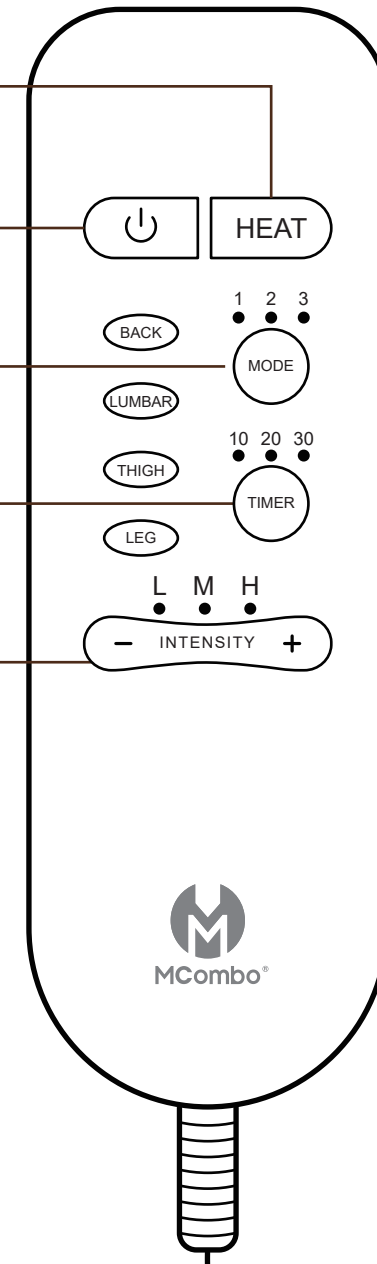

WARRANTY

Lift/Reclining Mechanism	1 Year
Upholstery Material	1 Year

Metal/Wood Chair Frame	1 Year
Electronic Parts	1 Year

LIMITATIONS APPLICABLE TO ALL WARRANTIES

All warranties begin on the date of delivery.

All warranties are to the original purchaser from EXACME/MCOMBO® ONLY.

- EXACME/MCOMBO® will replace the defective parts or send replacement chair provided that the warranty parts have not been subjected to misuse, abuse or improper service by the consumer, for example, damaged wire arising in consequence of negligence or improper operation.
- Exclusions also include components with damage caused by:
 - Contamination
 - Abuse, misuse, accident, or negligence
 - Commercial use, or use other than normal
 - Improper operation, maintenance, or storage

EXACME/MCOMBO® will pay standard shipping rates on all warranted parts for the first year. We can also sell you replacement part for a discount price when your chair is out of warranty policy.

NOTE: For lift chair beyond the limited manufacturer warranty period and scope, MCombo can also provide replacement service, but a basic charge will be charged according to the circumstances.

RETURN/REPLACEMENT POLICY

EXACME/MCOMBO®

All of lift recliners come with a 30-day return/replace policy. During this time, we will cover the shipping cost of return and replacement for defective and damaged chair, through providing pre-paid return label or pick-up service for customer convenience.

NOTE:

- (1) Please disassemble the chair before you return it, otherwise there will be a huge cost as oversized and it could even exceed your order amount.
- (2) Please do not purchase return label for a damaged/defective chair by yourself.
- (3) If you have any problem to return the chair, please contact us immediately, we will do our best to help you with a reasonable solution.

EXACME/MCOMBO® is not responsible for the returns that customer bought by mistake, changed their mind or other non-quality issues.

NOTE:

The customer is responsible for freight costs unless the chair is defective. Chairs returned due to being refused delivery by the customer or deemed undeliverable by freight carrier are subject to fees for a 20% restocking fee.

Why don't we recommend returning the item by yourself?

- Huge cost
- Need you to take the box to FedEx facility