

Assembly Instructions

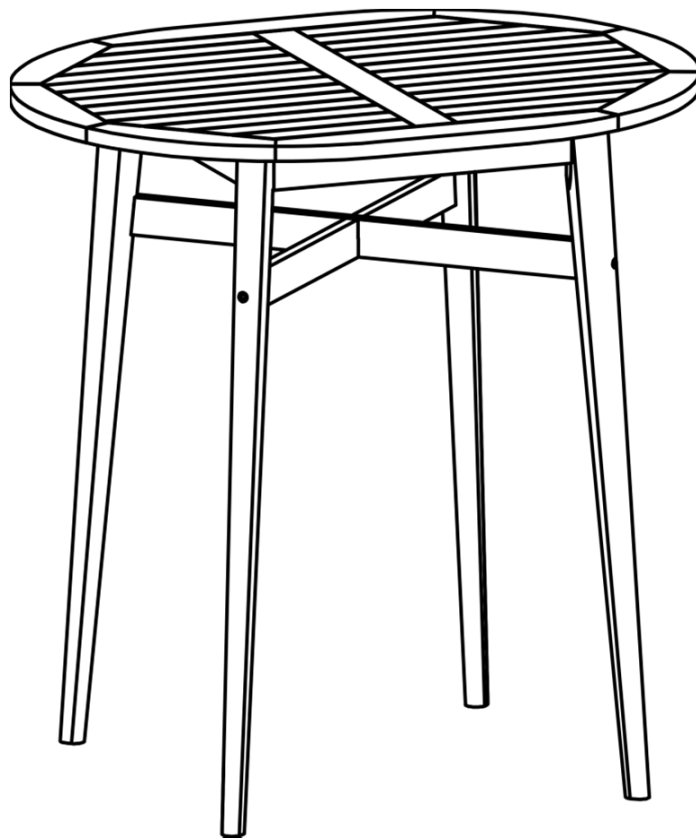

Caution: You must read this before you proceed

TABLE



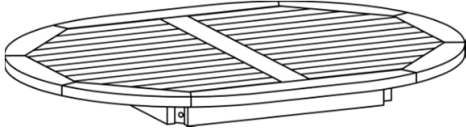

Caution: This Table is NOT a TOY
Keep your child/ children at bay during the assembly process.
Whenever moving/lifting the Table and to prevent damage to the Table,
two adults are needed to execute these actions.

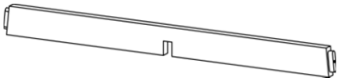
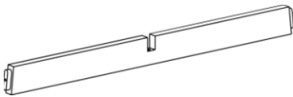
Parts List

Label	Picture	Description	QTY
A		Table Top	1
B		Legs	4
C		First Leg Support Bar	1
D		Second Leg Support Bar	1

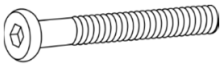
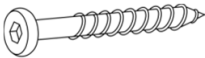
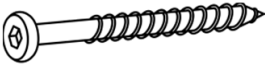
Hardware

Label	Picture	Description	QTY
①		Bolt (M8x50mm)	9
②		Screw (M6x45mm)	2
③		Screw (M6x90mm)	5
④		Washer	9
⑤		Allen Key	1

Assembly Preparation

Before Beginning Assembly:

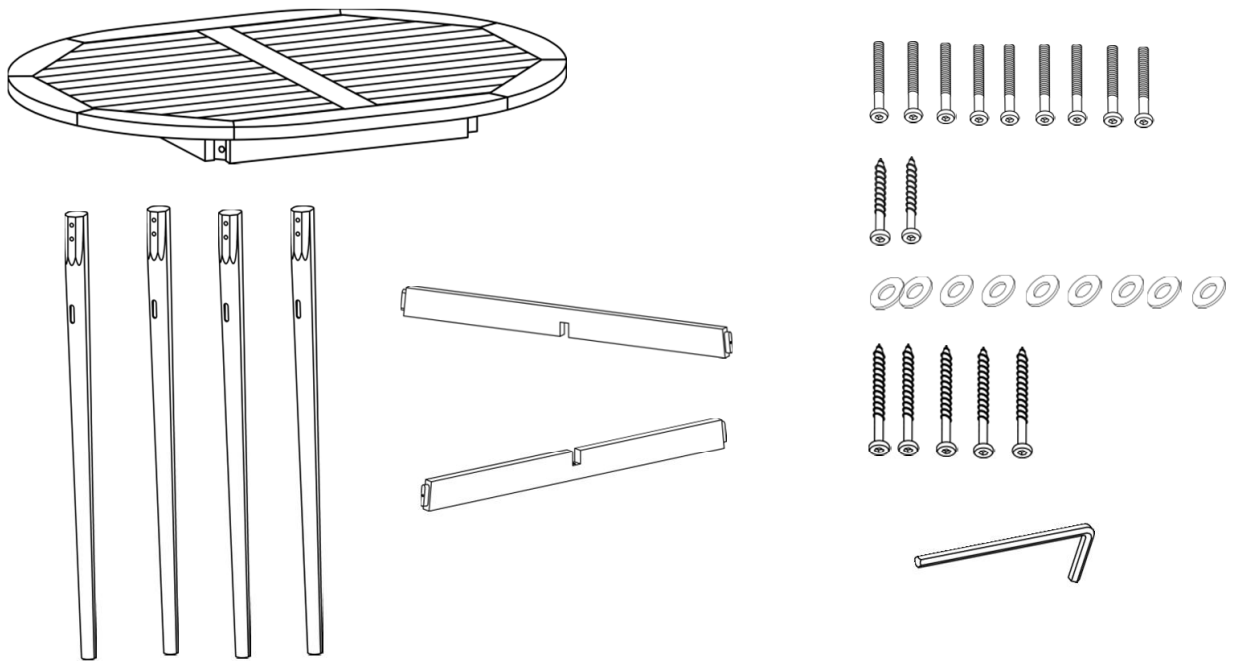

- Read instructions, cover to cover-



- Have 2 adults on hand for assembly-



- Do not assemble on flooring or carpet-



- Assemble on a clean non-marring surface (packing foam)-



- Save all packaging until finished-

Assembly Steps

Overview

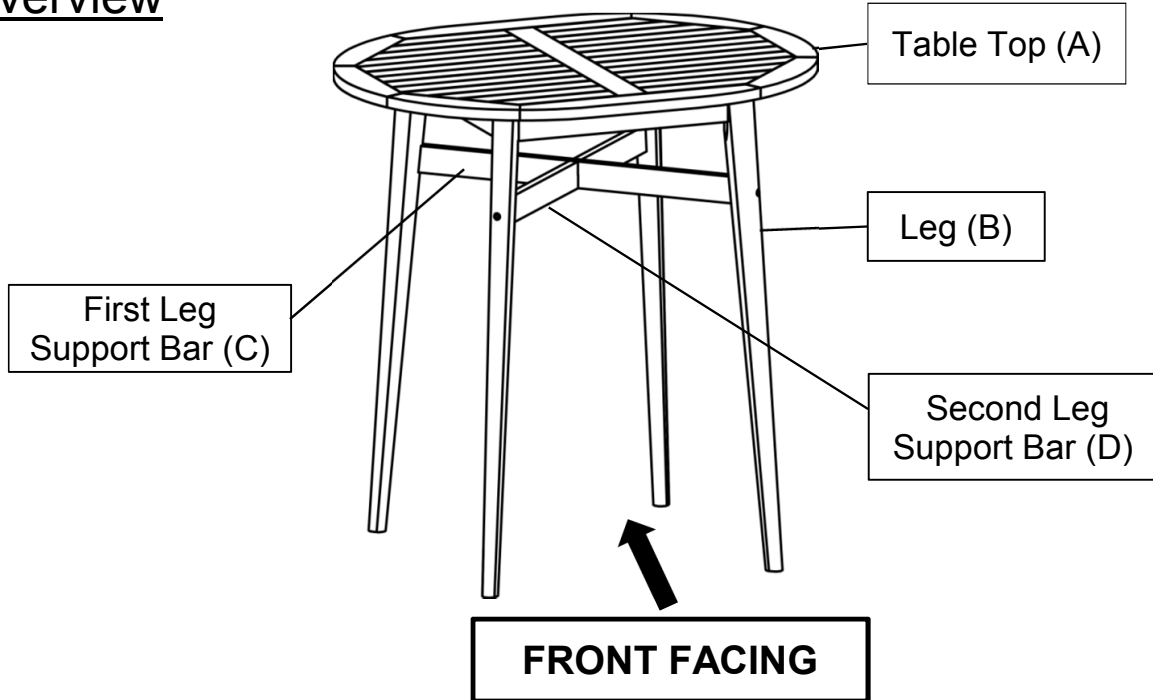

This Table has multiple parts and may require up to 30 minutes to assemble. To give you an overview of the Table parts, the above picture is to help you put the various parts into perspective. Please read through the instructions below to familiarise yourself with the parts and steps before assembly.

Step 1

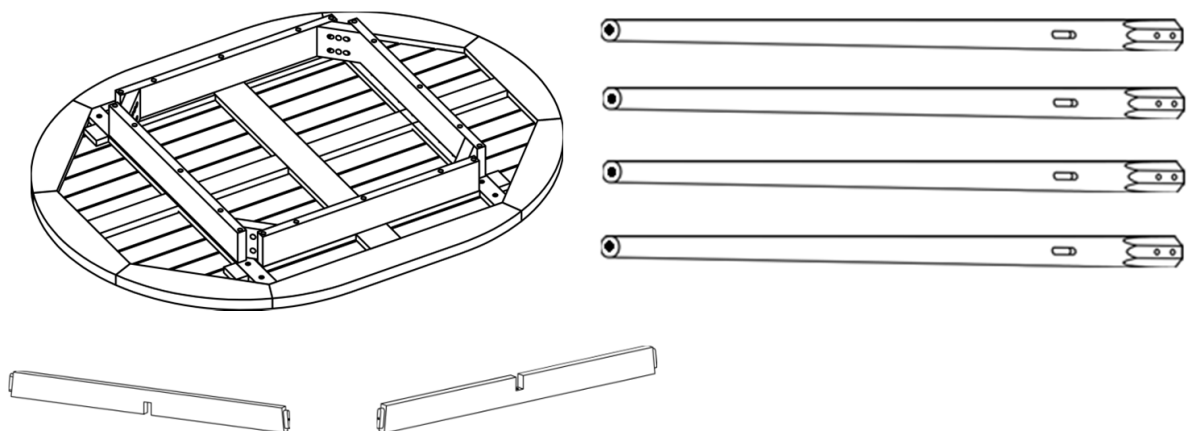

Unpack and place all parts on a clean, non-marring surface.

Step 2

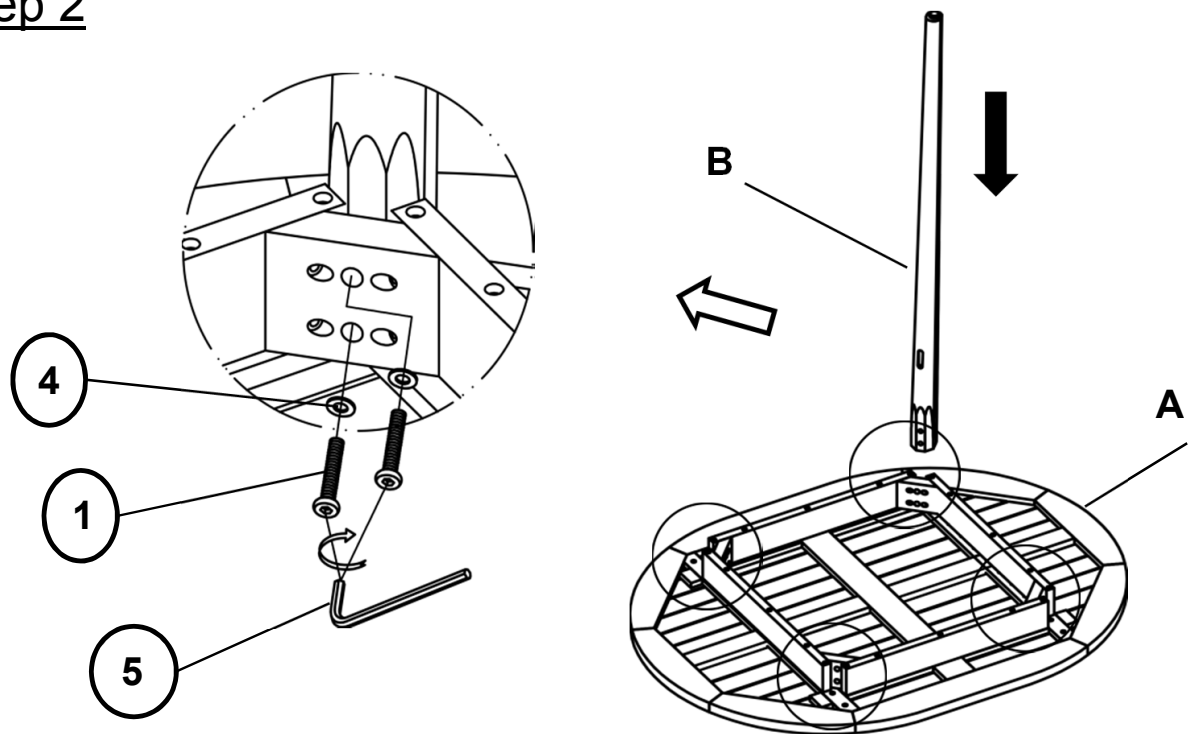

Attach Leg (B) to the Table Top (A) using Bolts(①), and Washers(④) with Allen Key(⑤).

Do not fully tighten the Bolts.

Repeat the same process with the remaining three Legs (B).

Step 3

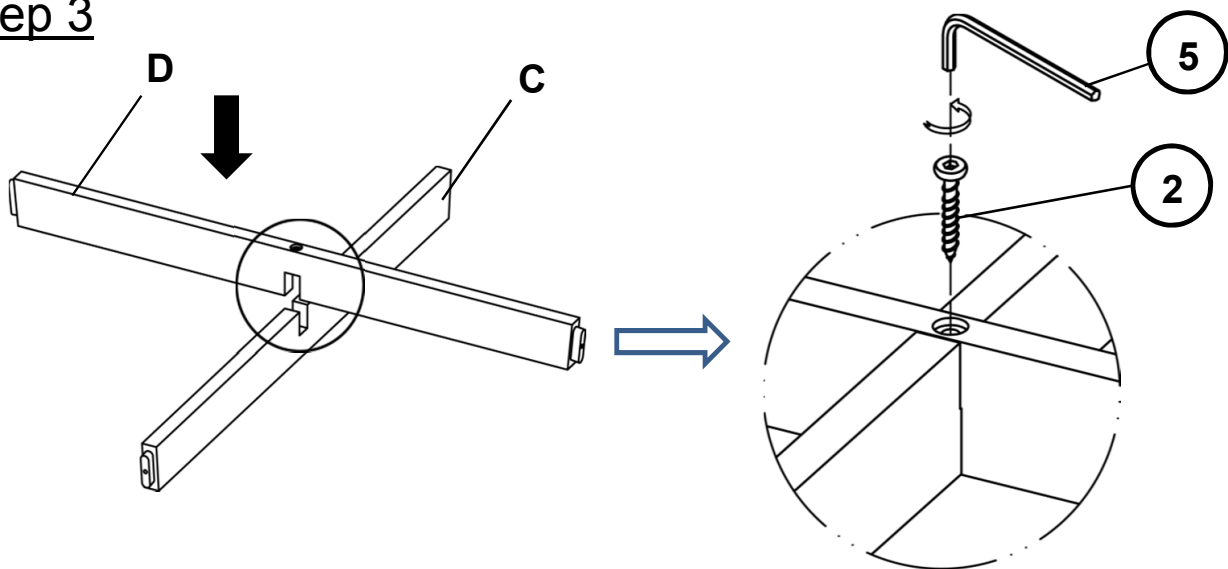

Place First Leg Support Bar(C) to Second Leg Support Bar (D), as shown above. Attach First Leg Support Bar(C) to Second Leg Support Bar (D) using Screws(②) with Allen Key(⑤).

Do not fully tighten Screws.

Step 4

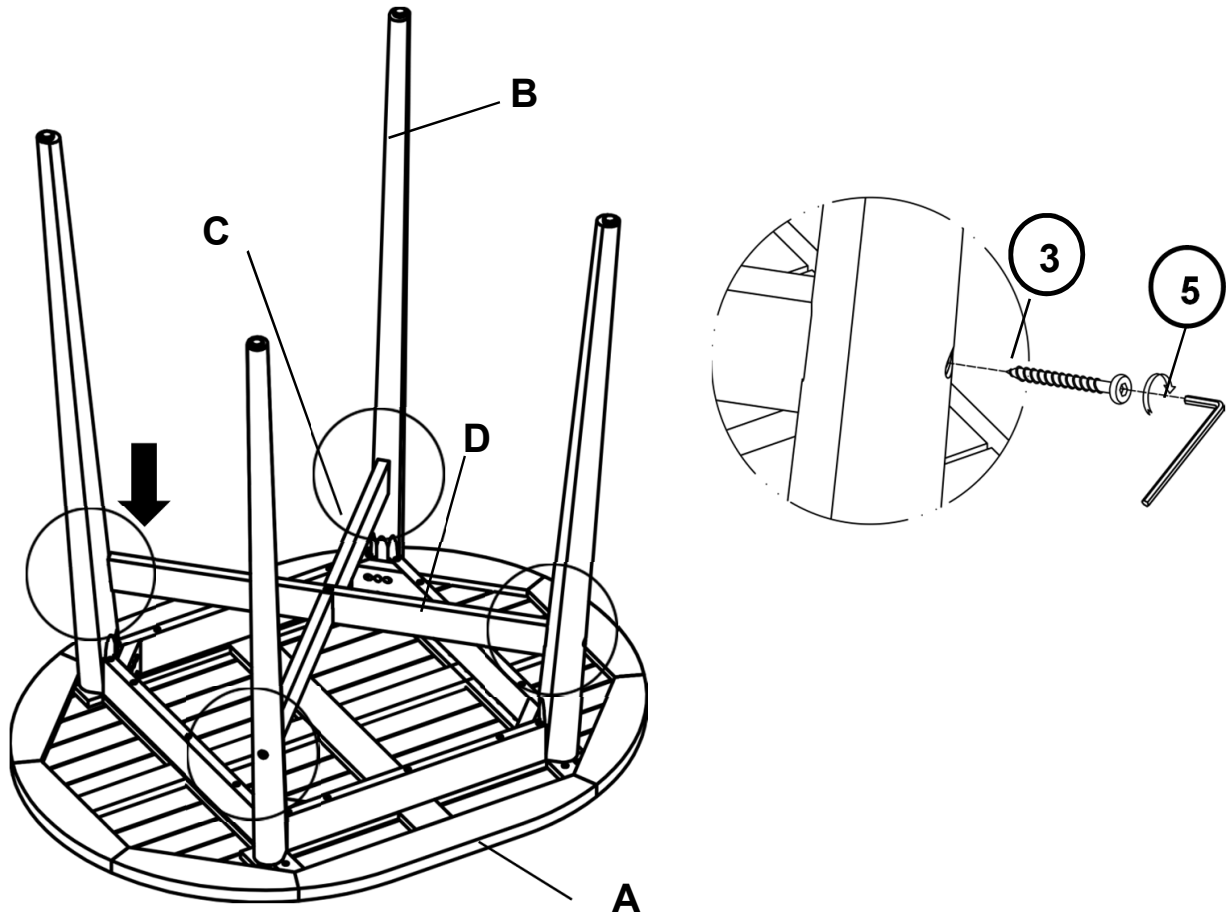

Attach the finished part in step 3 to the Legs (B), as shown above. You may need to apply a little pressure to the Legs-pushing outwards to enable place tenons from the finished part in step 3 into mortises on the Legs (B). Secure the finished part in step 3 to the Legs (B) using Screws(③) and Allen Key(⑤).

Do not fully tighten Screws.

Step 5

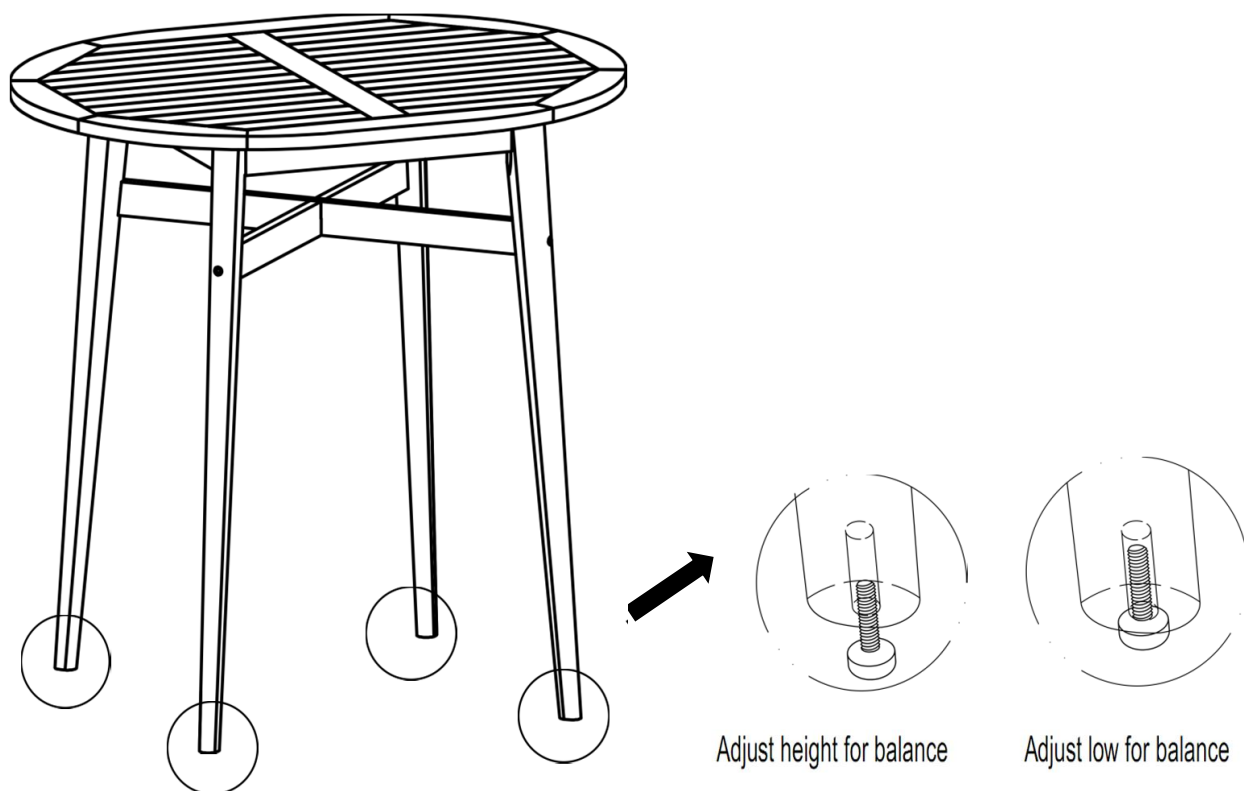

Adjust Pre-installed Levellers height for

Stand the Table up, with assistance from your adult partner.
Exert pressure floorwards, onto the Table with both your hands.
This pressure will help the Legs and Table Top reach full alignment status.
Check for wobbles on a LEVEL surface.

If no wobbles are found proceed to tighten the Bolts and Screws in a sequential manner, until evenly secured.

When tightening the Bolts and Screws tighten sequentially.

Do not tighten any Bolt or Screw fully and then move on towards the next one.

With assistance from your adult partners, adjust the Levellers to desired height to avoid wobbles.

If there are still wobbles, loosen the Bolts and Screws and execute the same above process.

If the Table is not Stable it could lead to damage to the product.



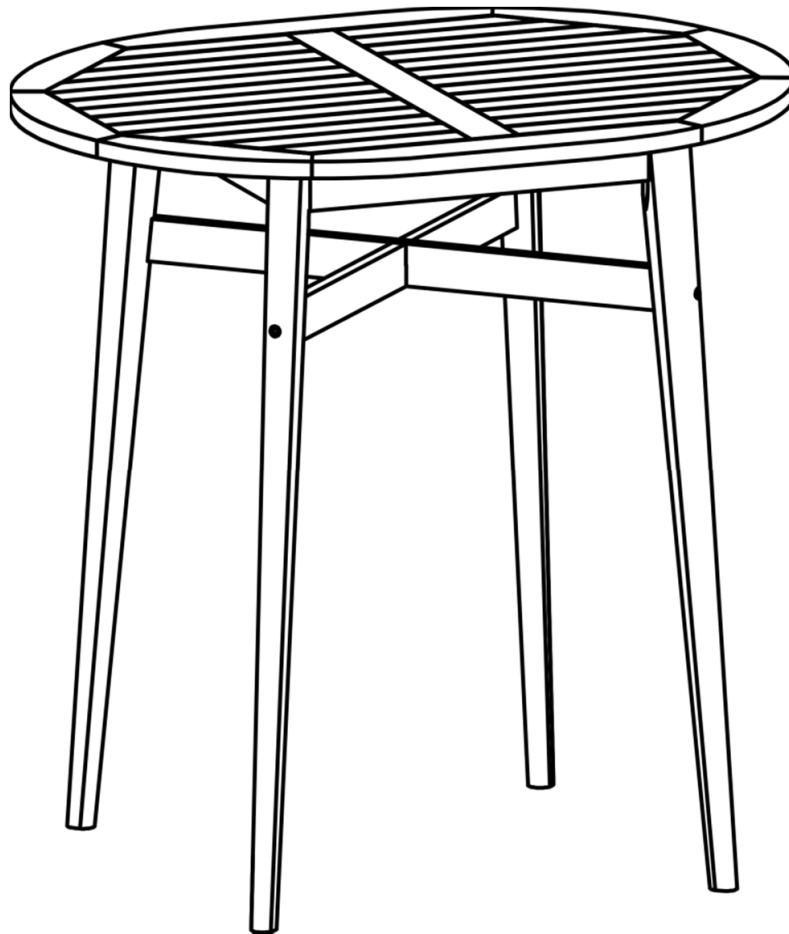





Step 5



Your Table is ready for use.

This Table can only be used on a flat, level surface.

Care & Maintenance

-  Do not put hot items directly on furniture surface
 -  Do not clean furniture with harsh cleansers or polish.
 -  To obtain the longest lifespan of your outdoor products, minimizing exposure to direct sunlight is recommended.
 -  Children should not climb or jump on the furniture.
 -  Do not write on furniture without a padded barrier to protect the surface.
 -  To obtain the longest lifespan of your outdoor products, avoid extended and lengthy exposure to rain, snow, and direct sunshine. Whenever possible cover the product and /or place under patio or awnings.
 -  Not for commercial use. For residential use only .
 -  Stains may be removed with mild soap solution and damp cloth.
-
-  Dust and pick-up spills using a clean, non-colored, lint-free cloth .