

# Montageanleitung | Instructions de montage Assembly Instructions | Instrucciones de montaje

SKU NUMBER: N616P264942W  
N616P264943W

N601P265421W  
N601P265422W

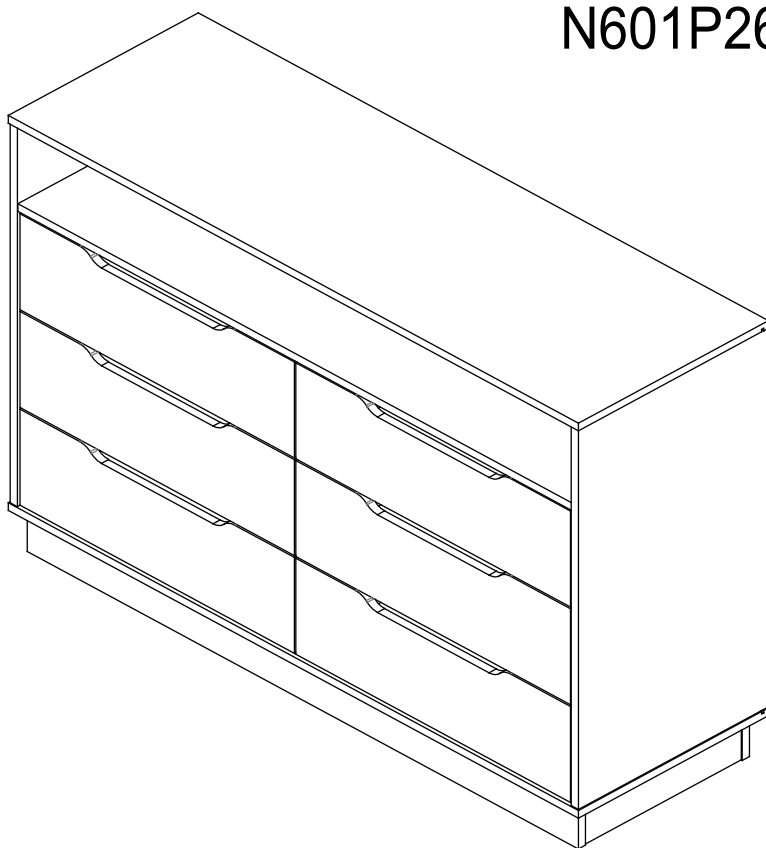

UK CA CE

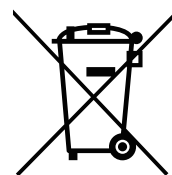

**GB** This set comes in 2 boxes. If you do not receive a full set of 2 boxes, please contact our customer service.

**DE** Dieses Set wird in 2 Schachteln geliefert. Wenn Sie nicht ein komplettes Set von 2 Boxen erhalten, kontaktieren Sie bitte unseren Kundenservice.

**FR** Ce set est livré en 2 boîtes. Si vous ne recevez pas un jeu complet de 2 boîtes, veuillez contacter notre service clientèle.

## English

### IMPORTANT ! KEEP FOR FUTURE REFERENCE : READ CAREFULLY

- To be assembled by an adult. Assembly must be checked by an adult before use.
- **WARNING !** Keep all screws, small parts and plastic bags out of the reach of children.
- Properly identify all parts before assembling.
- Anchor unit to stud or wall.
- Always use on a level, even surface.
- Avoid the risk of fire by not placing furniture near sources of ignition or hot items.
- **DO NOT** place hot or cold items directly onto the surface.
- **DO NOT** place the item next to a radiator or direct sunlight.
- **DO NOT** allow children to climb on unit.
- **DO NOT** put the product in a humid environment.

## Deutsch

### WICHTIG ! ZUM SPÄTEREN NACHSCHLAGEN AUFBEWAHREN: SORGFÄLTIG LESEN

- Muss von einem Erwachsenen zusammengebaut werden. Der Zusammenbau muss vor der Benutzung von einem Erwachsenen überprüft werden.
- **WARNUNG!** Bewahren Sie alle Schrauben, Kleinteile und Plastikbeutel außerhalb der Reichweite von Kindern auf.
- Kennzeichnen Sie vor dem Zusammenbau alle Teile ordnungsgemäß.
- Verankern Sie das Gerät an einem Ständer oder einer Wand.
- Benutzen Sie das Gerät immer auf einer ebenen, geraden Fläche.
- Vermeiden Sie das Risiko eines Brandes, indem Sie die Möbel nicht in der Nähe von Zündquellen oder heißen Gegenständen aufstellen.
- Stellen Sie **KEINE** heißen oder kalten Gegenstände direkt auf die Oberfläche.
- Stellen Sie das Gerät **NICHT** in der Nähe eines Heizkörpers oder direkter Sonneneinstrahlung auf.
- Erlauben Sie Kindern **NICHT**, auf das Gerät zu klettern.
- Stellen Sie das Gerät **NICHT** in einer feuchten Umgebung auf.

## Français

### IMPORTANT ! CONSERVER POUR RÉFÉRENCE ULTÉRIEURE : LIRE ATTENTIVEMENT

- A assembler par un adulte. Le montage doit être vérifié par un adulte avant utilisation.
- **ATTENTION !** Conservez toutes les vis, les petites pièces et les sacs en plastique hors de portée des enfants.
- Identifiez correctement toutes les pièces avant de les assembler.
- Fixer l'appareil à un montant ou à un mur.
- Utilisez toujours l'appareil sur une surface plane et uniforme.
- Évitez les risques d'incendie en ne plaçant pas les meubles à proximité de sources d'inflammation ou d'objets chauds.
- **NE PAS** placer d'objets chauds ou froids directement sur la surface.
- **NE PAS** placer l'appareil à côté d'un radiateur ou de la lumière directe du soleil.
- **NE PAS** laisser les enfants grimper sur l'appareil.
- **NE PAS** placer le produit dans un environnement humide.

**Italiano**

**IMPORTANTE! CONSERVARE PER RIFERIMENTO FUTURO: LEGGERE ATTENTAMENTE**

- Deve essere assemblato da un adulto. L'assemblaggio deve essere controllato da un adulto prima dell'uso.
- **AVVERTENZA !** Tenere tutte le viti, le piccole parti e i sacchetti di plastica fuori dalla portata dei bambini.
- Identificare correttamente tutte le parti prima dell'assemblaggio.
- Ancorare l'unità a un pilastro o a una parete.
- Utilizzare sempre su una superficie piana e uniforme.
- Evitare il rischio di incendio non collocando i mobili vicino a fonti di accensione o ad oggetti caldi.
- **NON** collocare oggetti caldi o freddi direttamente sulla superficie.
- **NON** collocare l'apparecchio vicino a un termosifone o alla luce diretta del sole.
- **NON** permettere ai bambini di arrampicarsi sull'unità.
- **NON** collocare il prodotto in un ambiente umido.

**Español**

**¡ IMPORTANTE ! CONSERVELO PARA FUTURAS CONSULTAS: LEA ATENTAMENTE**

- Debe montarlo un adulto. El montaje debe ser comprobado por un adulto antes del uso.
- **ADVERTENCIA** Mantenga todos los tornillos, piezas pequeñas y bolsas de plástico fuera del alcance de los niños.
- Identifique correctamente todas las piezas antes del montaje.
- Ancle la unidad a un montante o pared.
- Utilí celo siempre sobre una superficie plana y nivelada.
- Evite el riesgo de incendio no colocando los muebles cerca de fuentes de ignición o artículos calientes.
- **NO** coloque objetos calientes o fríos directamente sobre la superficie.
- **NO** coloque el mueble cerca de un radiador o de la luz solar directa.
- **NO** permita que los niños se suban a la unidad.
- **NO** coloque el producto en un ambiente húmedo.

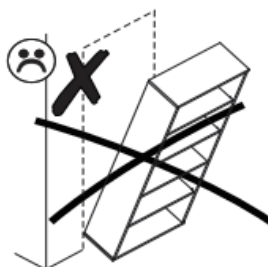
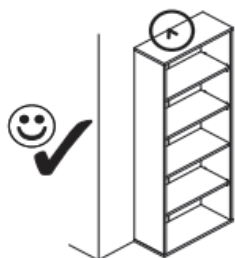

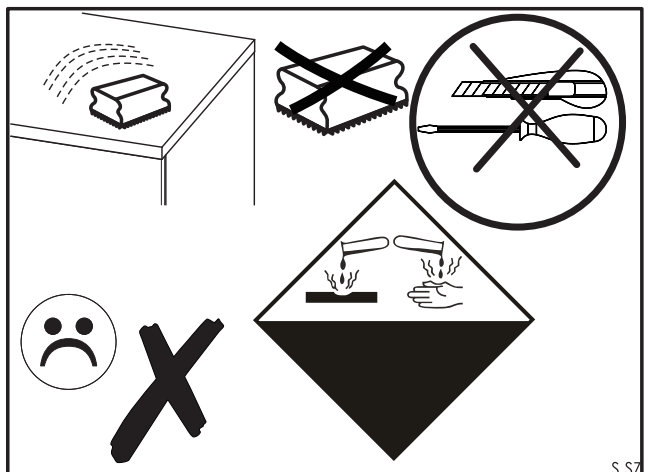
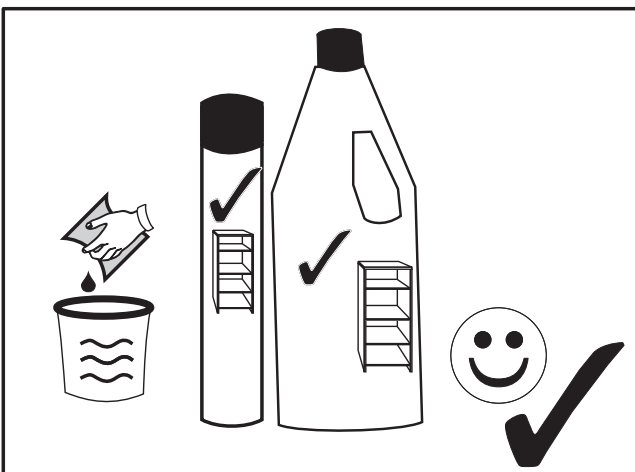
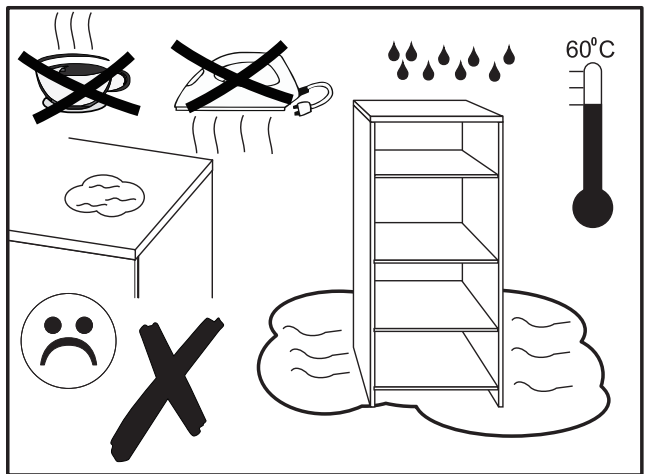
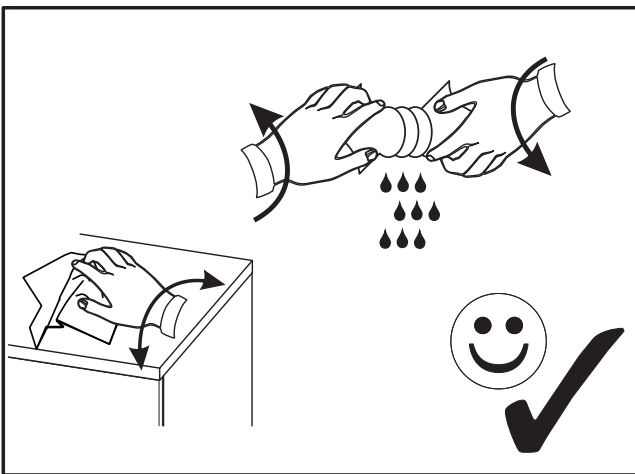
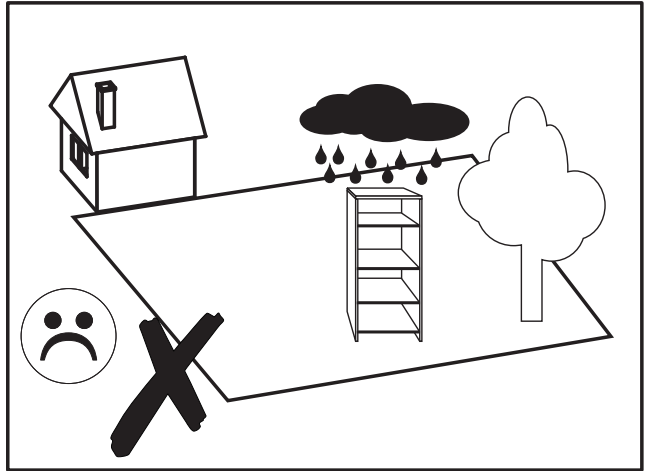
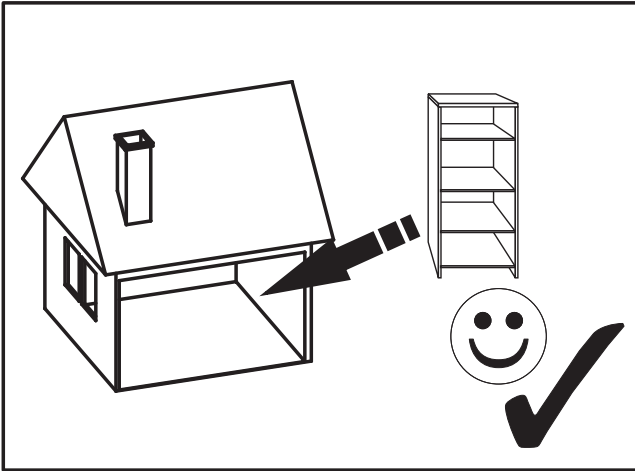

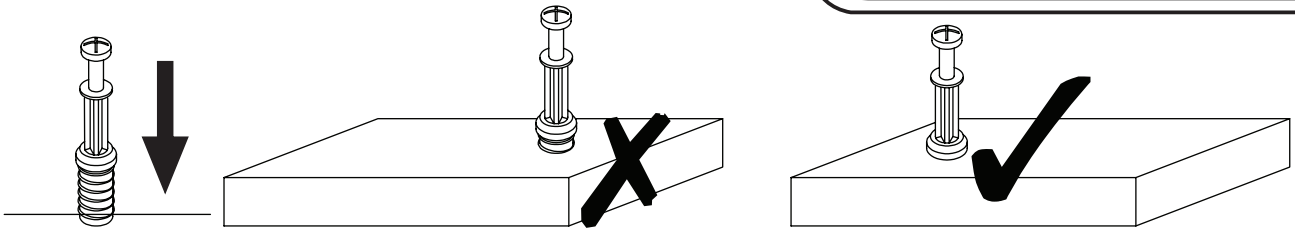

**EN\_QUICKFIT:** Tighten quickfit until shoulder is flush with panel. Do not overtighten or undertighten.

**FR\_RACCORD RAPIDE:** Faites serrer le raccord rapide jusqu'à ce que l'épaulement soit parfaitement encastré dans le panneau. Il ne faut ni trop serrer ni insuffisamment serrer.

**ES\_QUICKFIT:** Apriete quickfit hasta que el hombro se descargue con el panel. NO lo sobreapriete ni lo apriete poco.

**DE\_QUICKFIT:** Ziehen Sie den Quickfit fest, bis die Schulter mit der Platte bündig ist. Bitte nicht zu fest oder zu schwach anziehen.

**IT\_MONTAGGIO RAPIDO:** Stringere il montaggio rapido fino a quando la spalla è a filo con il pannello, non stringere troppo o troppo poco.

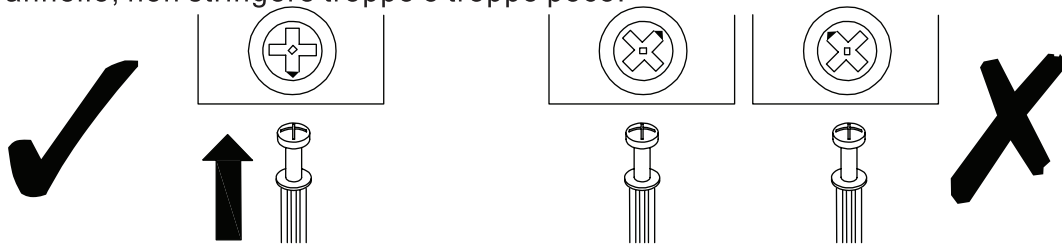

**EN\_CAM LOCK:** When fitting cam lock, ensure starting position is correct before you insert connecting quickfit.

**FR\_SERRURE BATTEUSE:** Avant d'insérer la serrure batteuse, veillez à la bonne orientation avant d'insérer le raccord rapide.

**ES\_CIERRE DE LA CÁMARA:** Cuando instale el cierre de la cámara, asegúrese de que la posición de inicio es correcta antes de que inserte el quickfit conector.

**DE\_CAM-LOCK:** Achten Sie bei der Montage des Cam-Locks auf die richtige Ausgangsposition, bevor Sie den Quickfit einsetzen.

**IT\_BLOCCAGGIO A CAMMA:** Quando si monta il bloccaggio a camma, assicurarsi che la posizione iniziale sia corretta prima di inserire il montaggio rapido di collegamento.

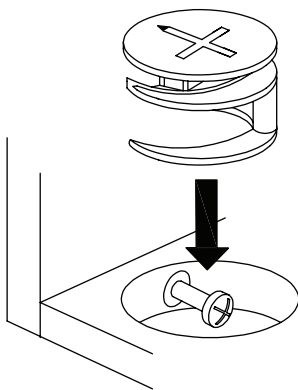

**EN\_Quickfit head** should be in the centre of the cam lock when the two panels are joined.

Cam lock should be inserted before quickfit.

**FR\_Lorsque** les deux panneaux sont assemblés, la tête du raccord rapide doit reposer au centre de la serrure batteuse. Il faut insérer la serrure batteuse avant le raccord rapide.

**ES\_El** cabezal del quickfit debe estar en el centro del cierre de la cámara cuando se unan los dos paneles.

Se debe insertar el cierre de la cámara antes que el quickfit.

**DE\_Der** Quickfit-Kopf sollte sich in der Mitte des Cam-Locks befinden, wenn die beiden Platten zusammengefügt sind.

Der Cam-Lock sollte vor dem Quickfit eingesetzt werden.

**IT\_La** testa del montaggio rapido deve trovarsi al centro del bloccaggio a camma quando i due pannelli sono uniti.

Il Bloccaggio a Camma deve essere inserito prima del montaggio rapido.

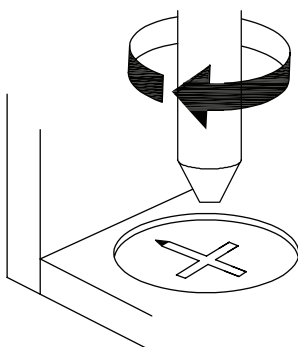

**EN\_Turn** cam lock clockwise to tighten.

**FR\_Faites** tourner la serrure batteuse dans le sens des aiguilles d'une montre pour la resserrer.

**ES\_Gire** el cierre de la cámara en sentido horario para apretarlo.

**DE\_Drehen** Sie den Cam-Lock im Uhrzeigersinn, um ihn festzuziehen.

**IT\_Ruotare** il bloccaggio a camma in senso orario per stringere.

# GETTING TO KNOW YOUR PRODUCT

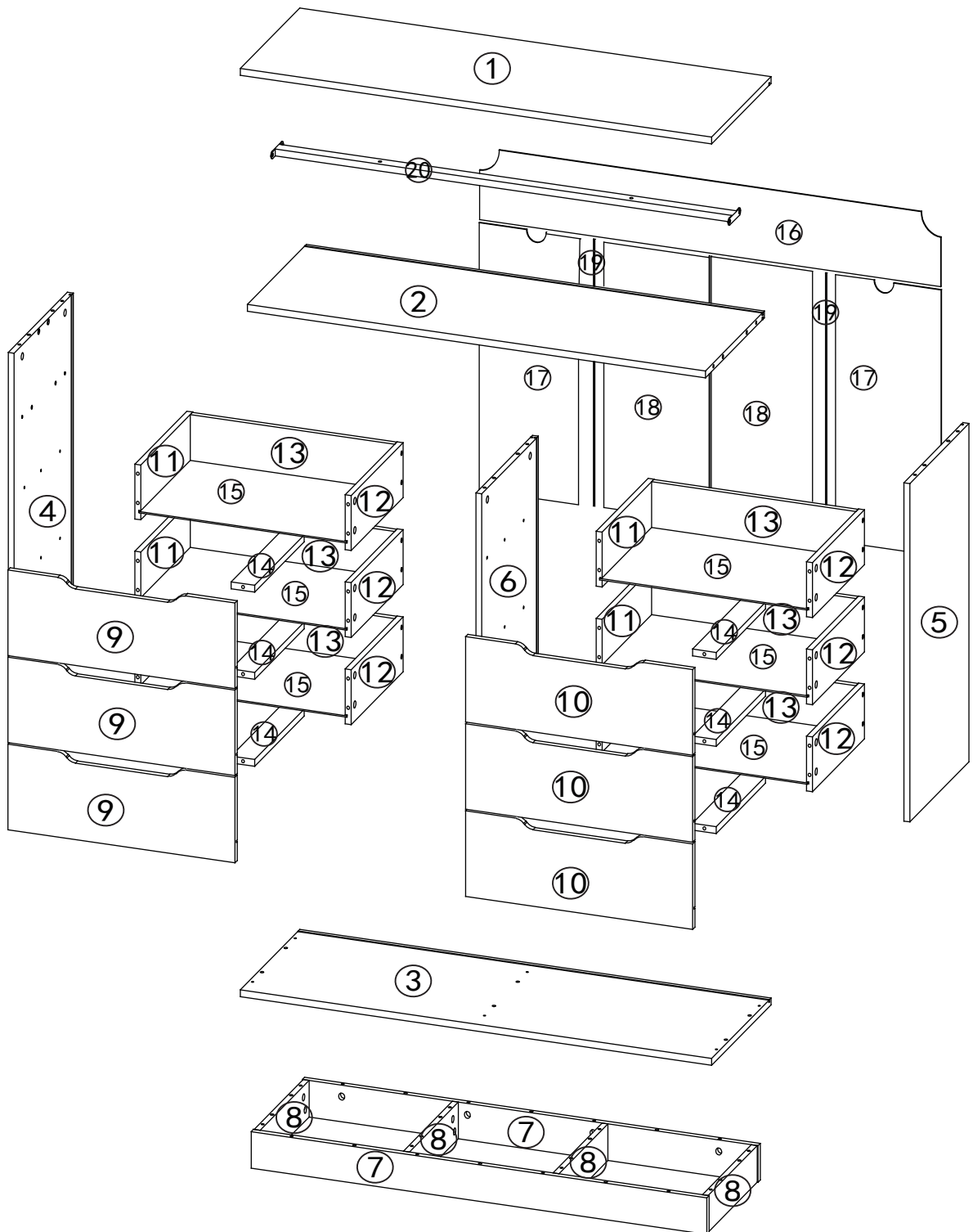





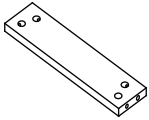
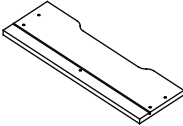
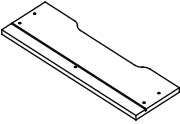
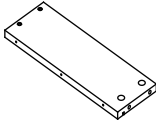
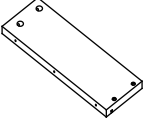
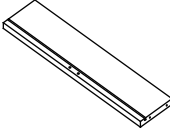
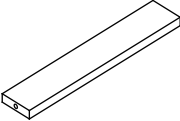
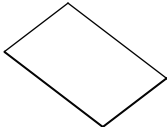





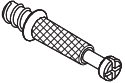

# Part List/ Teileliste/ Liste des pièces

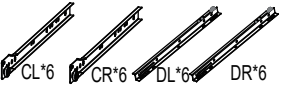
N616P264942W / N601P265421W

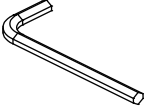
8		X4	9		X3
10		X3	11		X6
12		X6	13		X6
14		X6	15		X6

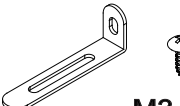

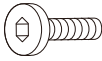
# Hardware List/ Hardware-Liste/ Liste du matériel

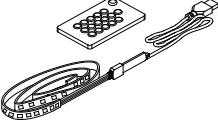
N616P264942W / N601P265421W

A	 M6*24	X64	B	 Φ 15*9.6	X64
C	 Ø8*30	X38	D	 Φ4 x 35	X42
E	 350 mm	X6	F	 M5*10	X36
G	 M3.5*14	X36	H		X1
I	 M3.5*16	X6	J	 M3.5*14	X2
K		X2	L	 M6*12	X4
M	 M6*40	X2	N		X1

# Part List/ Teileliste/ Liste des pièces

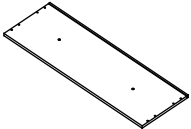
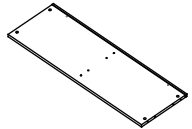
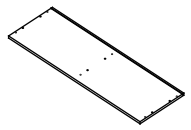
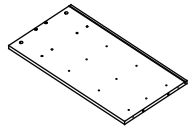
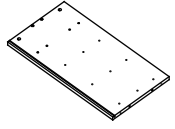
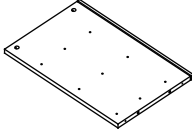
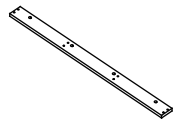
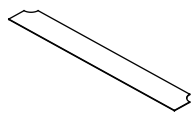
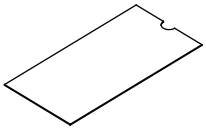
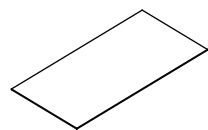
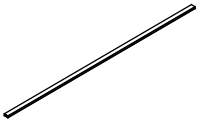
N616P264943W / N601P265422W

1		X1	2		X1
3		X1	4		X1
5		X1	6		X1
7		X2	16		X1
17		X2	18		X2
19		X2	20		X1

Notwendige ausrüstung (ausgenommen ausgenommen not included

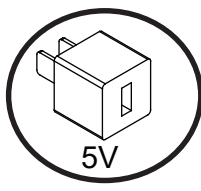
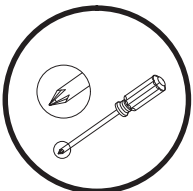

1

M6\*24  
A X 24

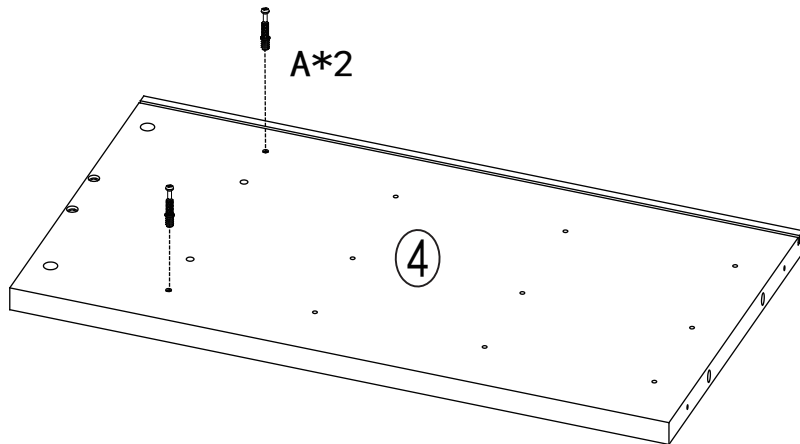
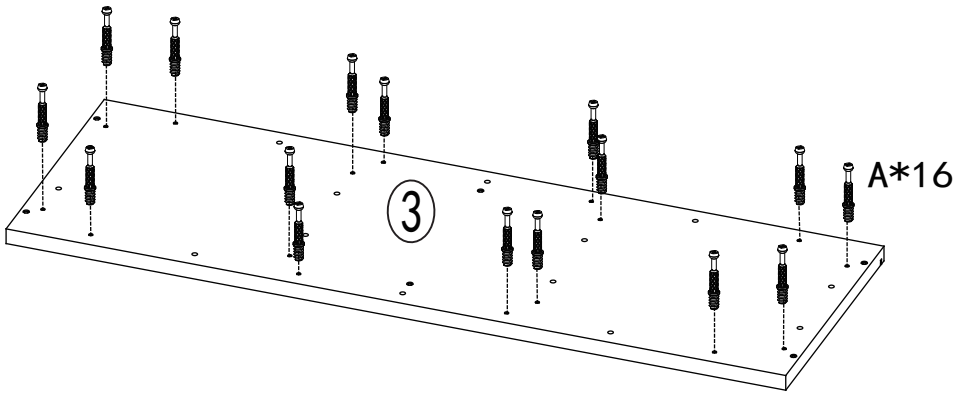
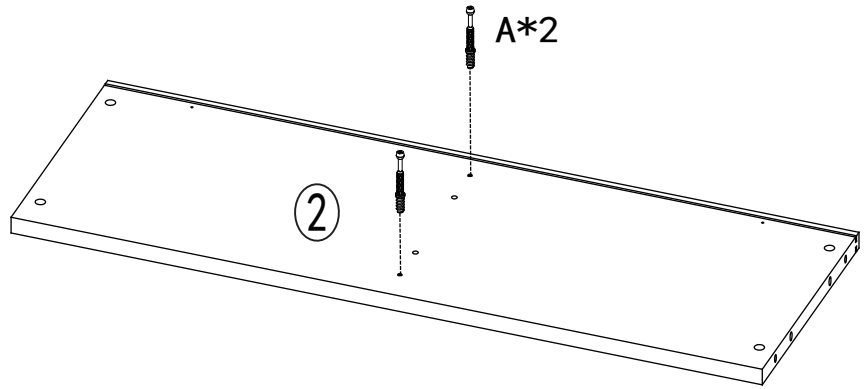
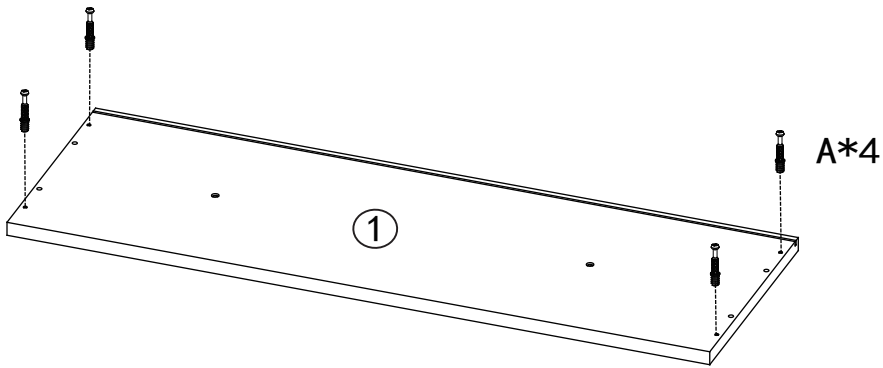

2

M6\*24  
A X 40

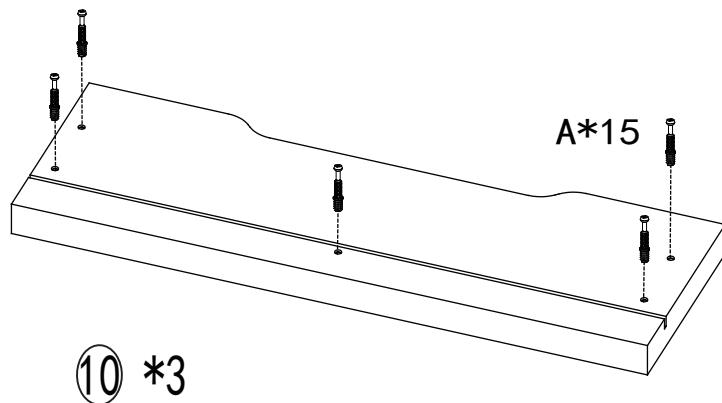
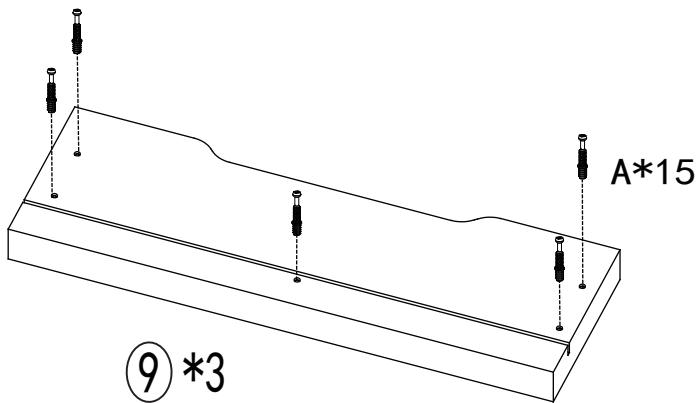
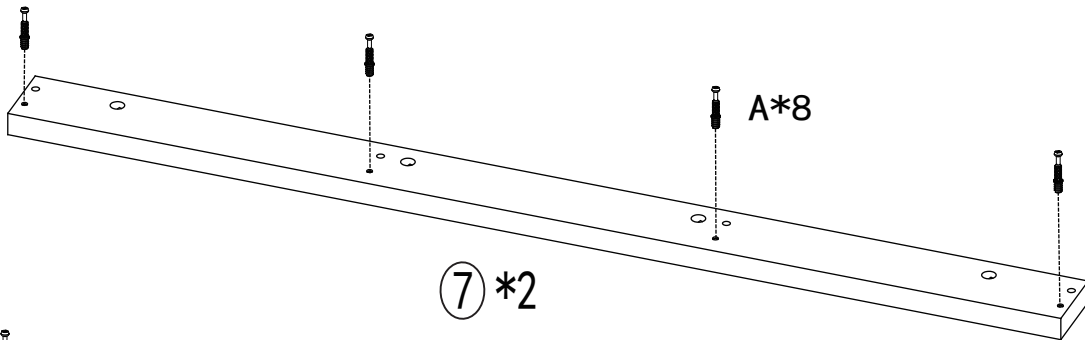
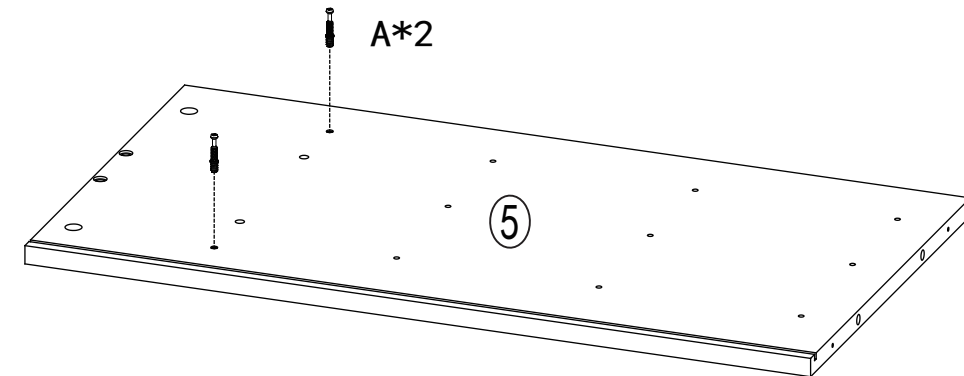

3

Ø8\*30  
C X 38

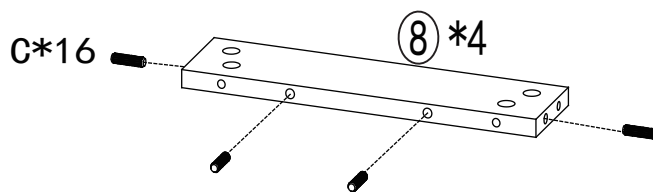
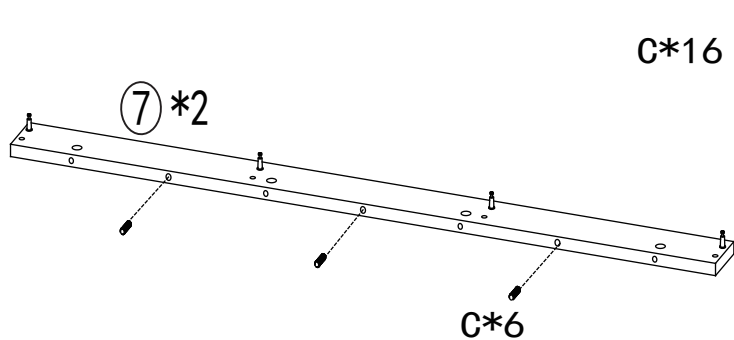
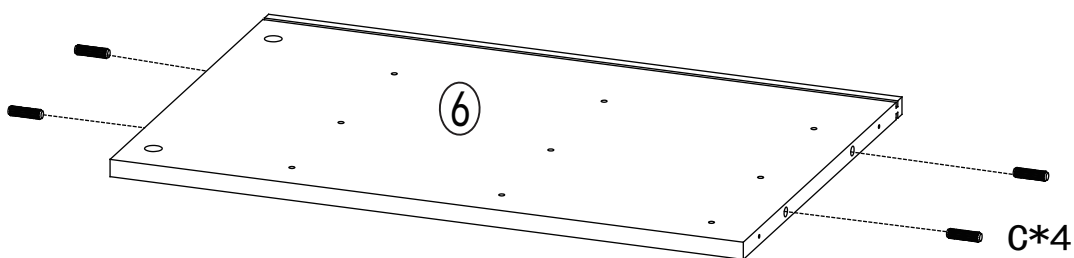
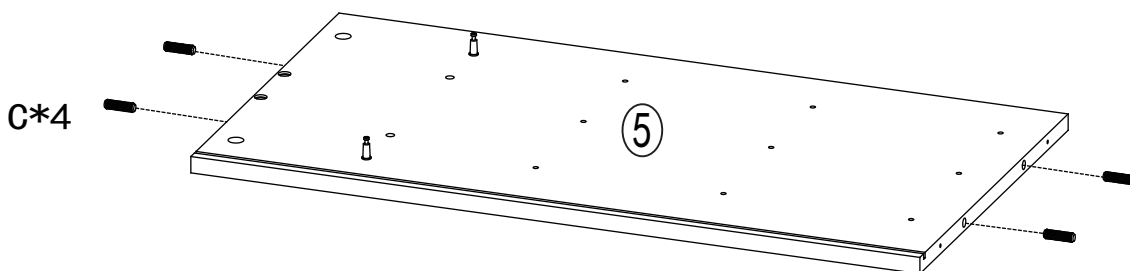
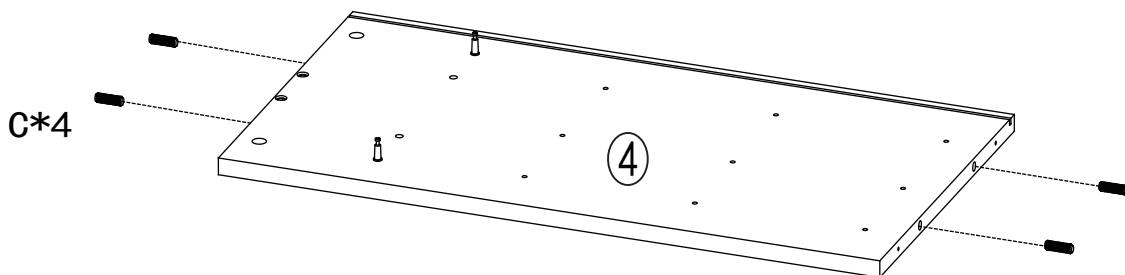
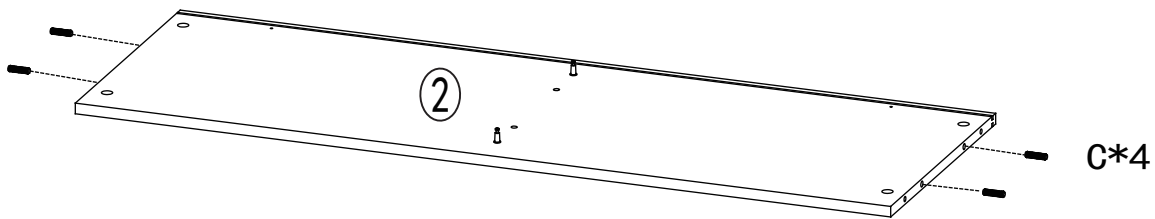

4

E:CL X 3

E:CR X 3

M5\*10  
F X 18



M3.5\*14  
J X 2

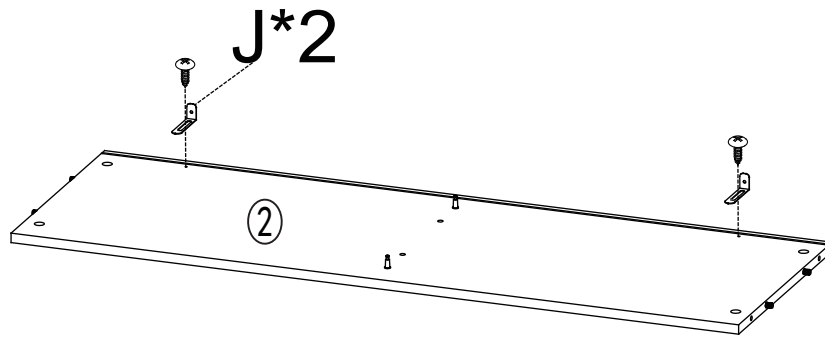

④: E:CL

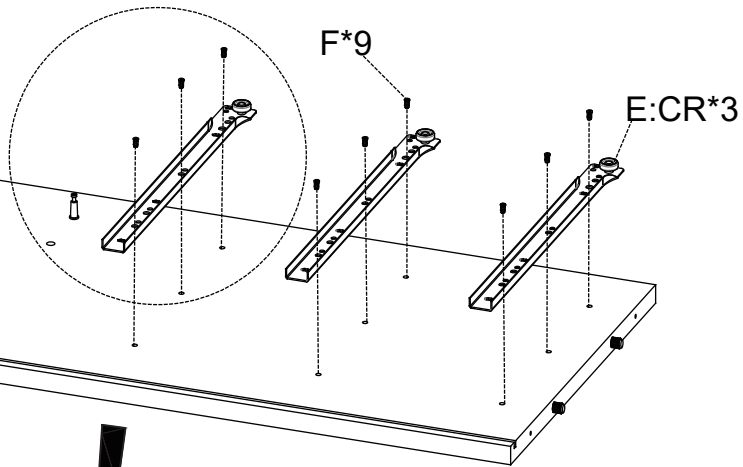
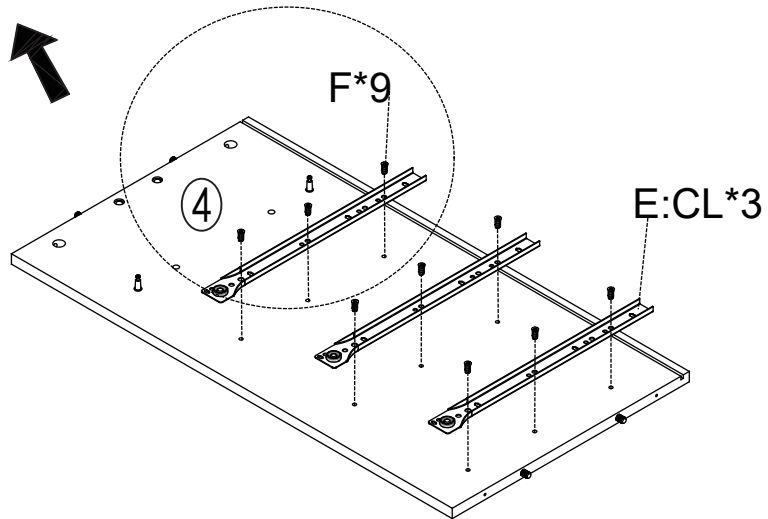
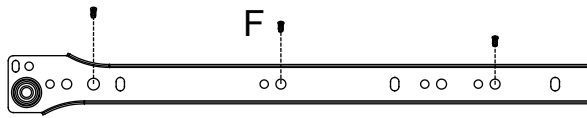

⑤: E:CR

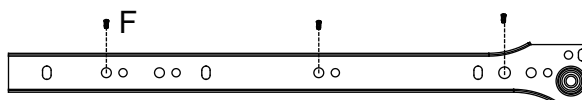

5

E:CL X 3

E:CR X 3

M5\*10  
F X 18

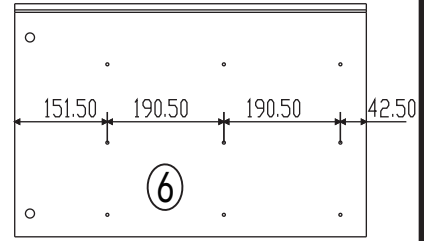

6: E:CL

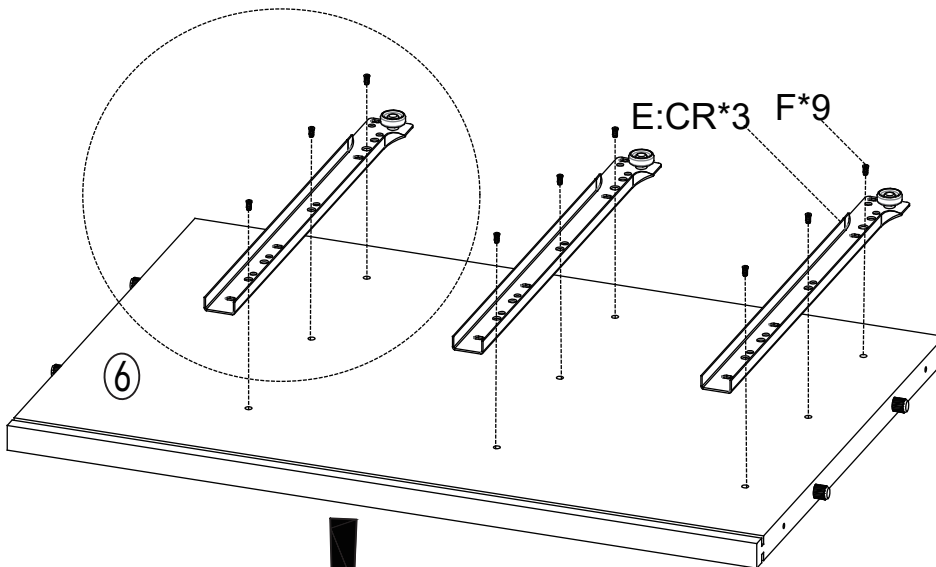
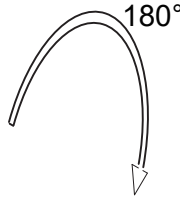
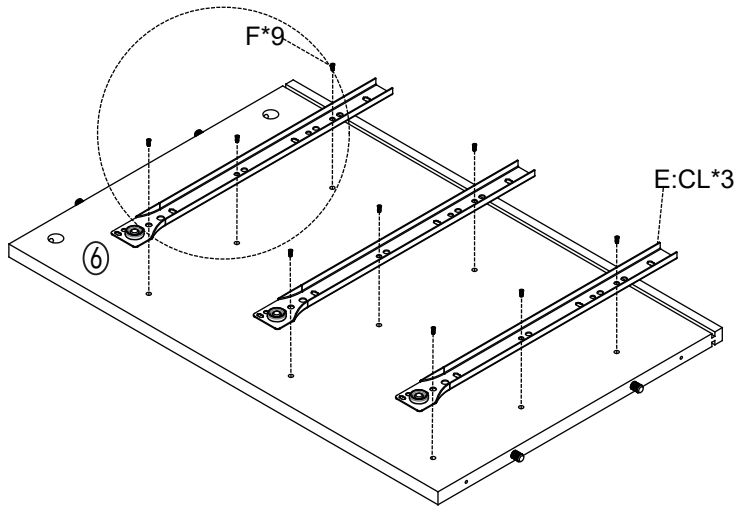
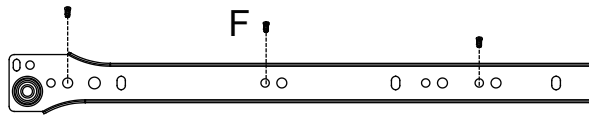

6: E:CR

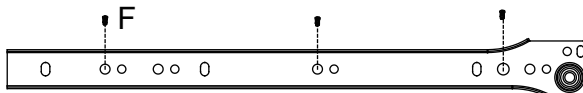

6 X6	 E:DL X 3	 E:DR X 3	M3.5*14  G X 36

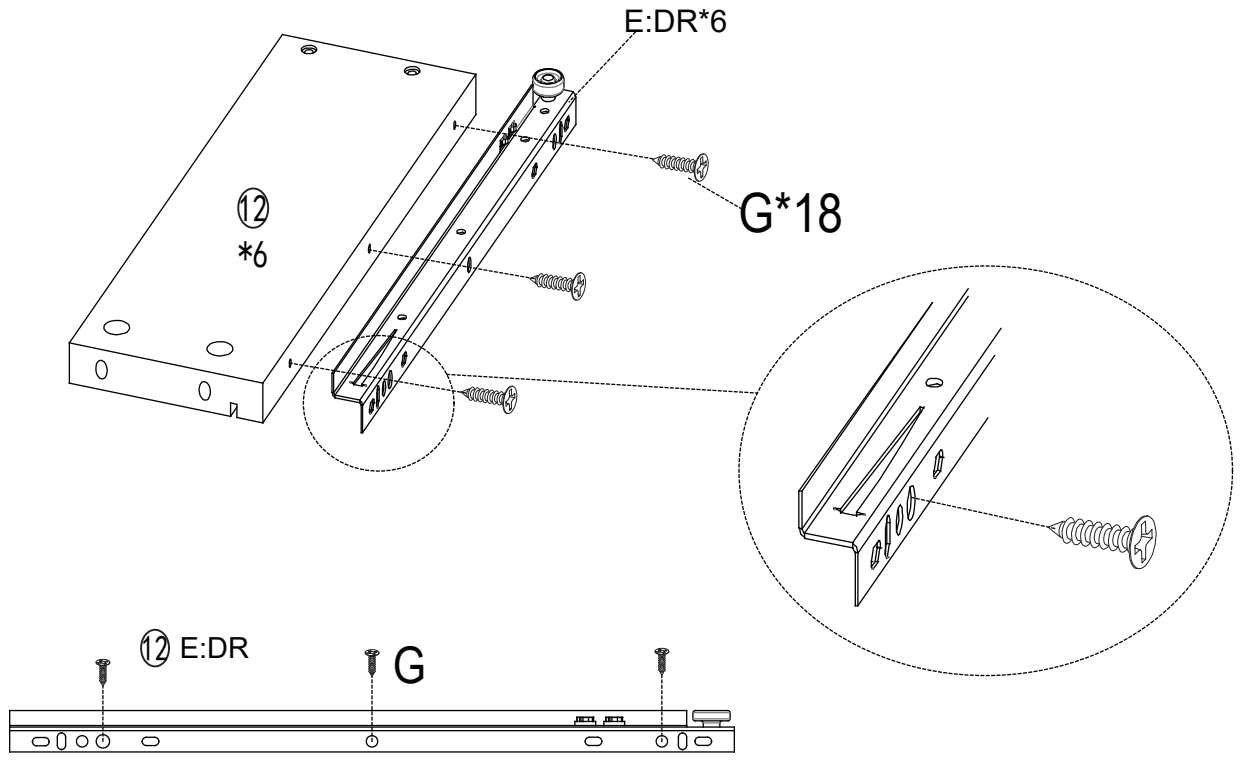
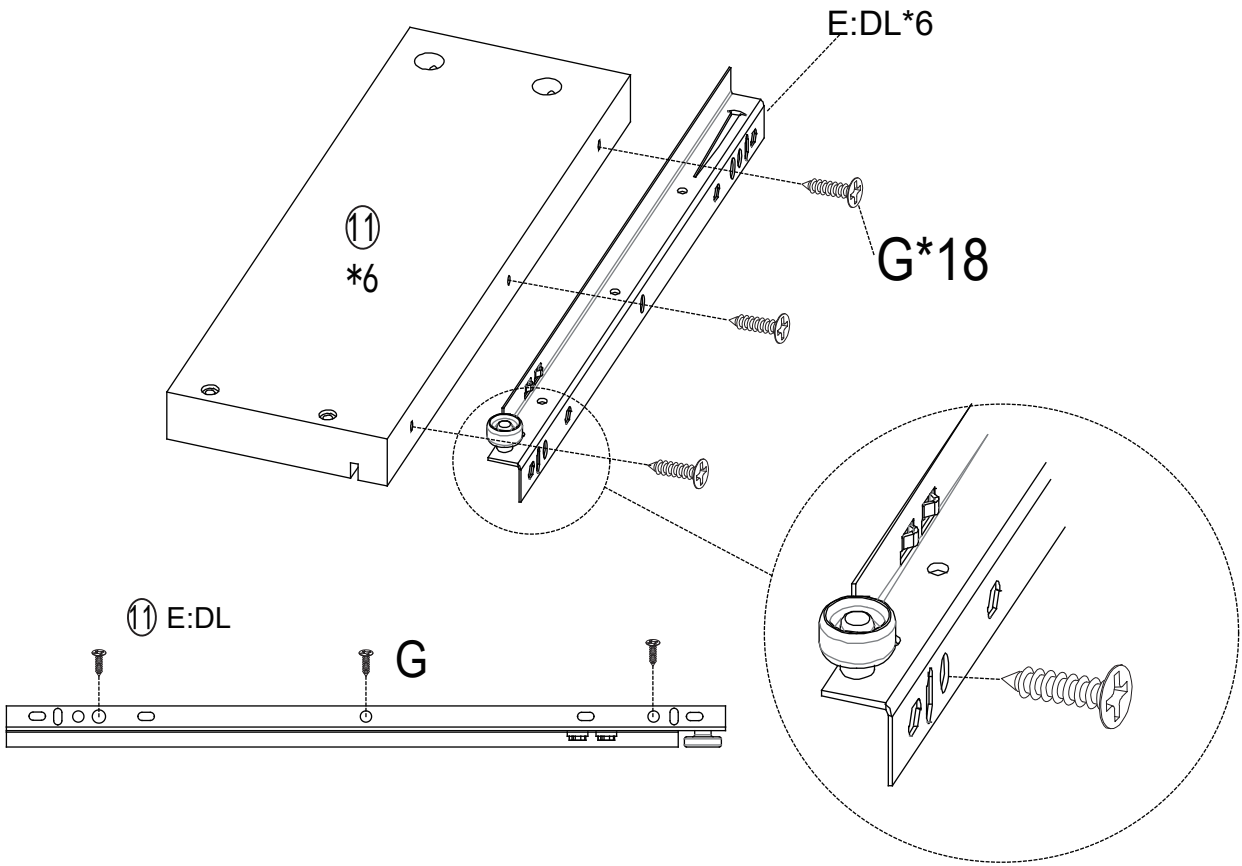

7  
X3

$\Phi 15 \times 9.6$



B X 15

$\Phi 4 \times 35$



D X 18

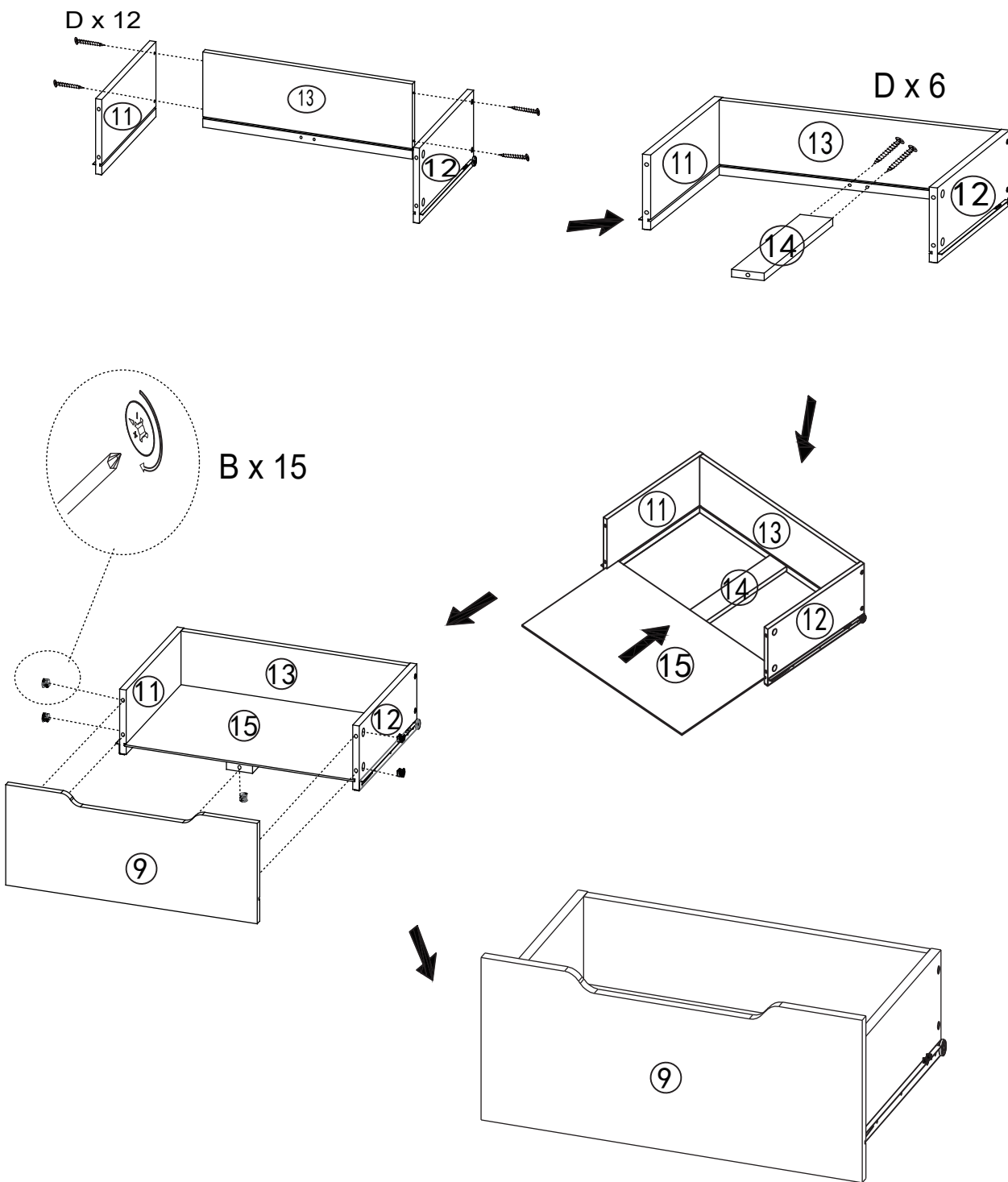
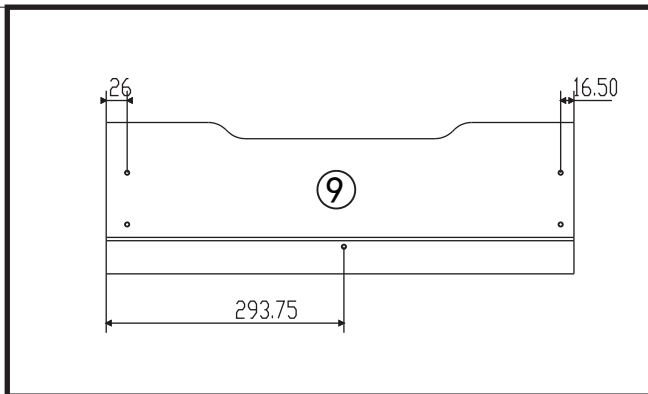

8  
X3

$\Phi 15 \times 9.6$   
B X 15

$\Phi 4 \times 35$   
D X 18

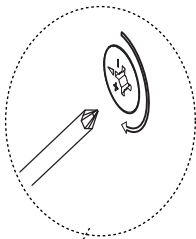
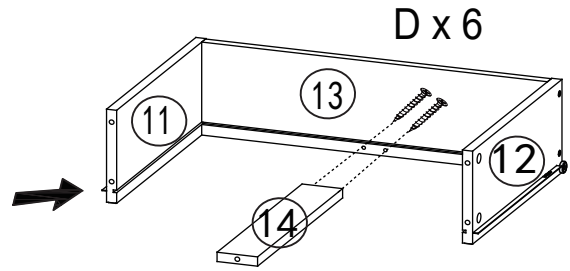
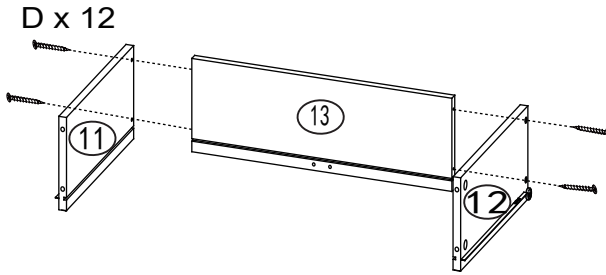
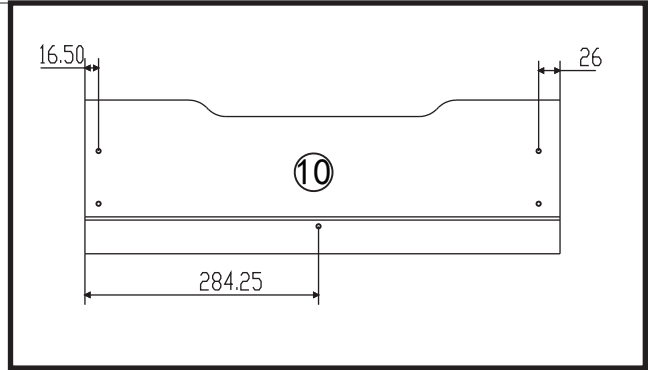

B x 15

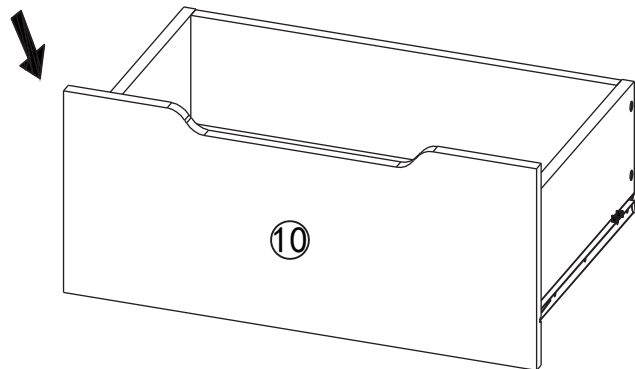
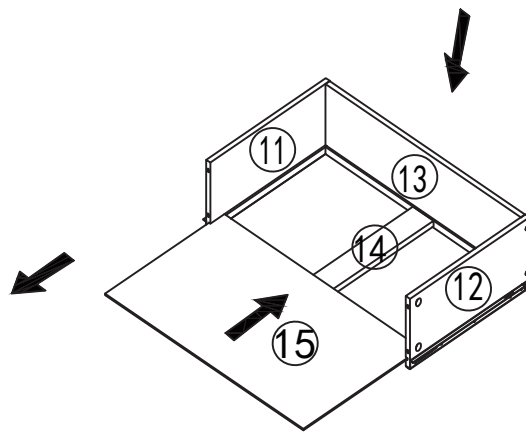
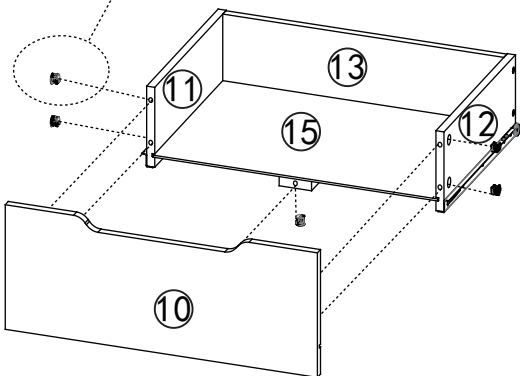

10 X3

9

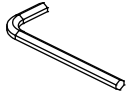

H X 1

M6\*40



M X 2

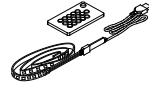

N X 1

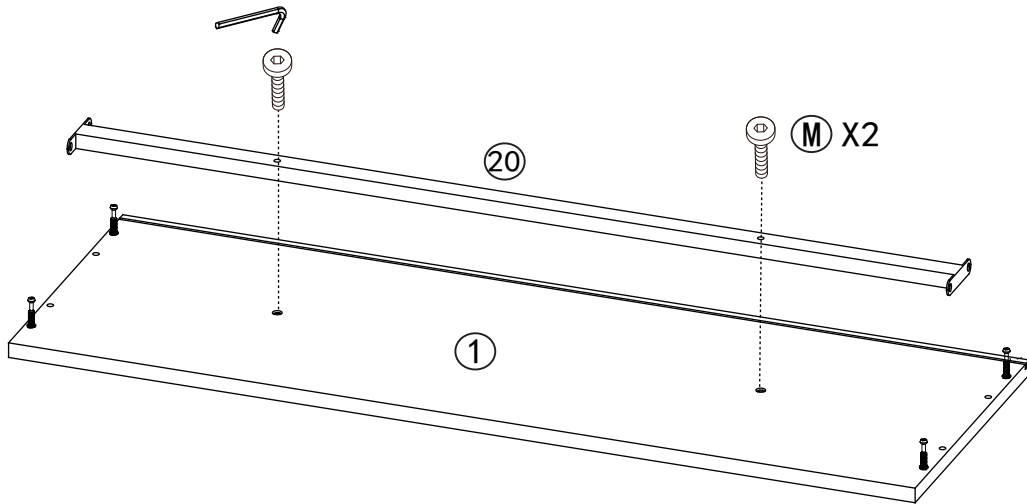

180°

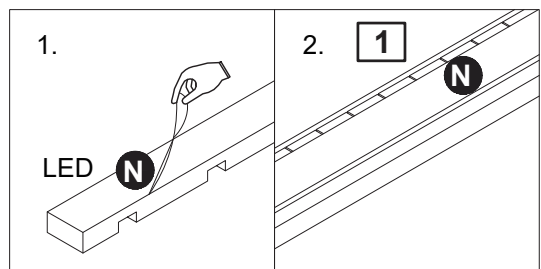
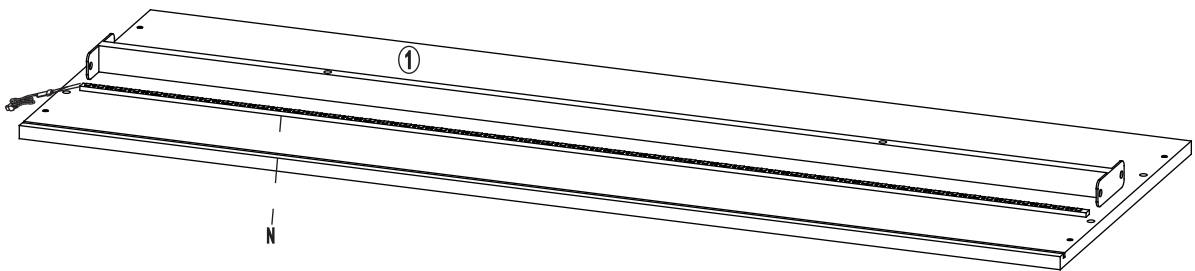

10

$\Phi 15 \times 9.6$



B X 2

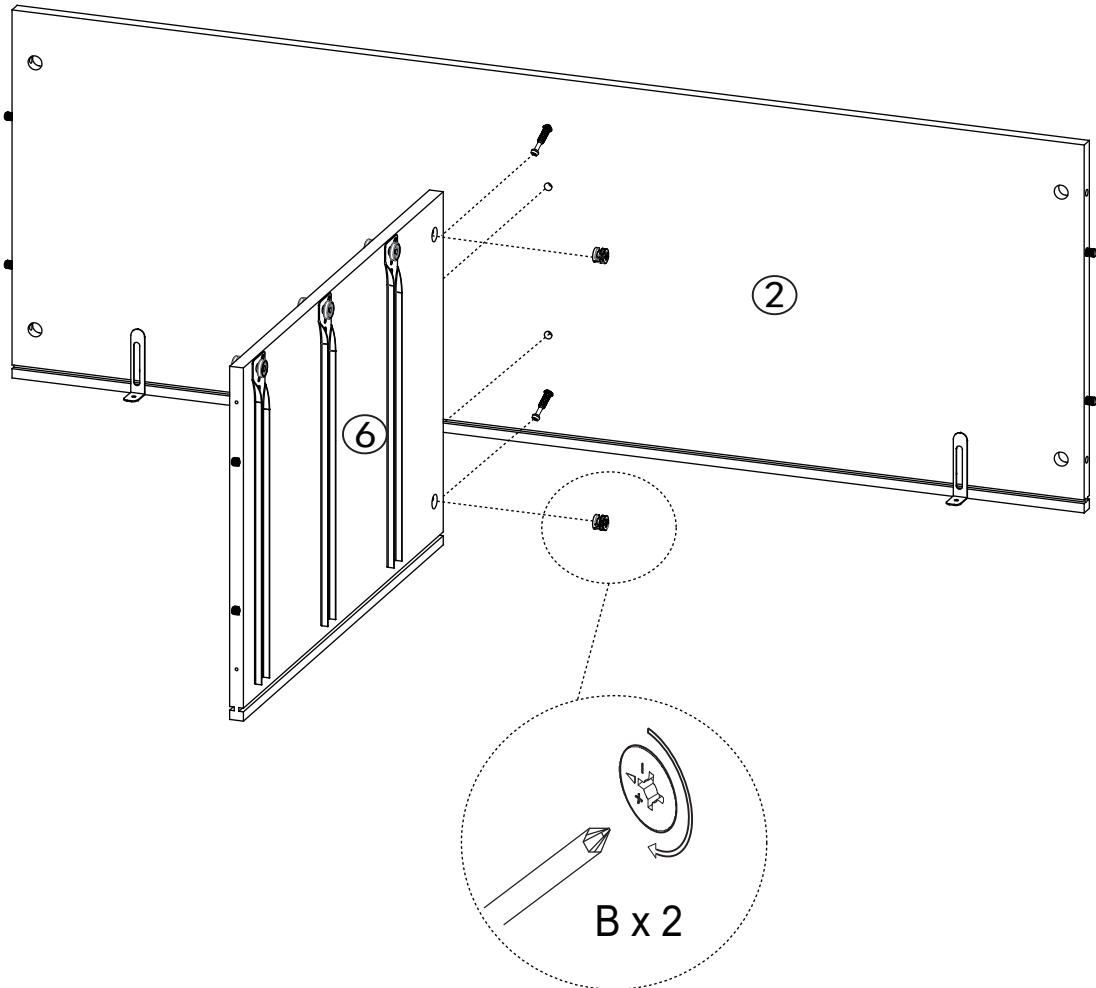

11

$\Phi 15 \times 9.6$



B X 4

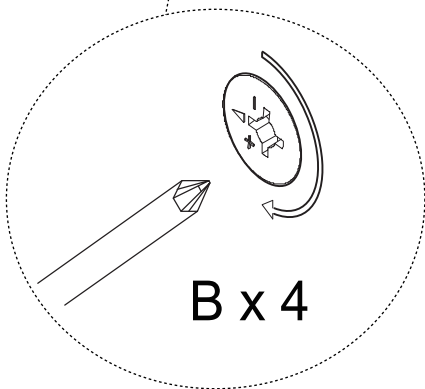
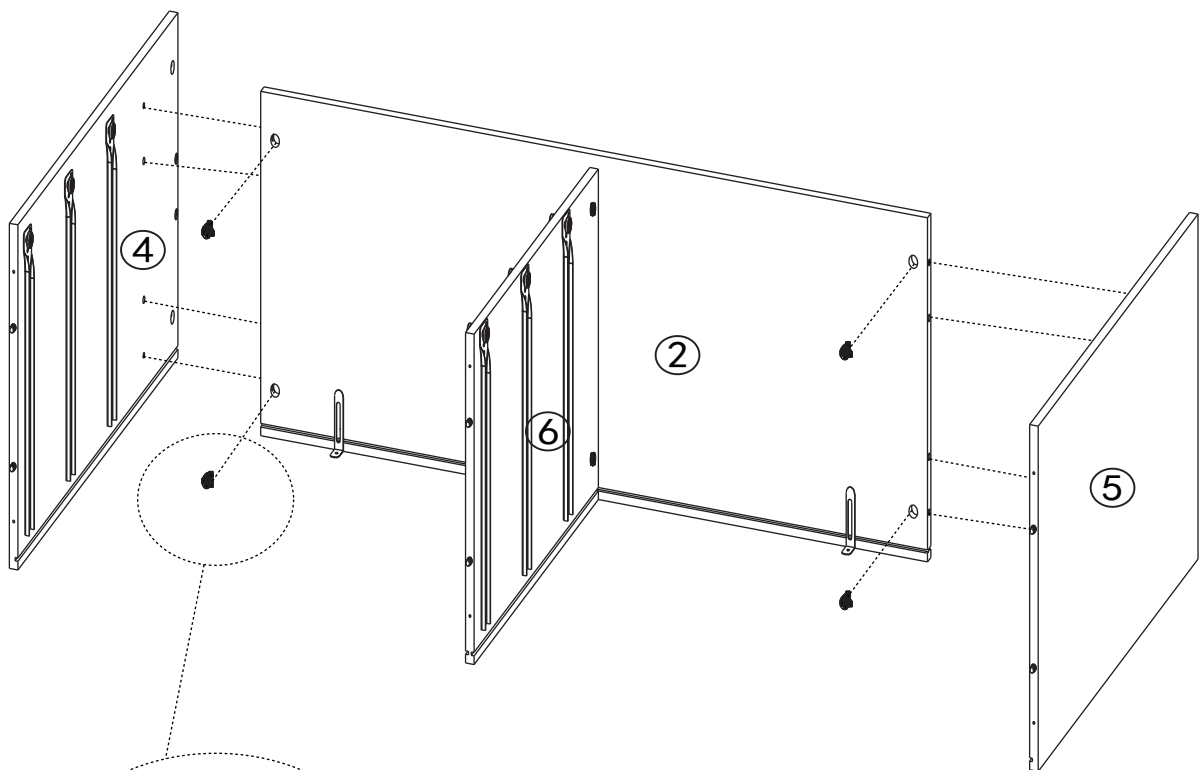

12

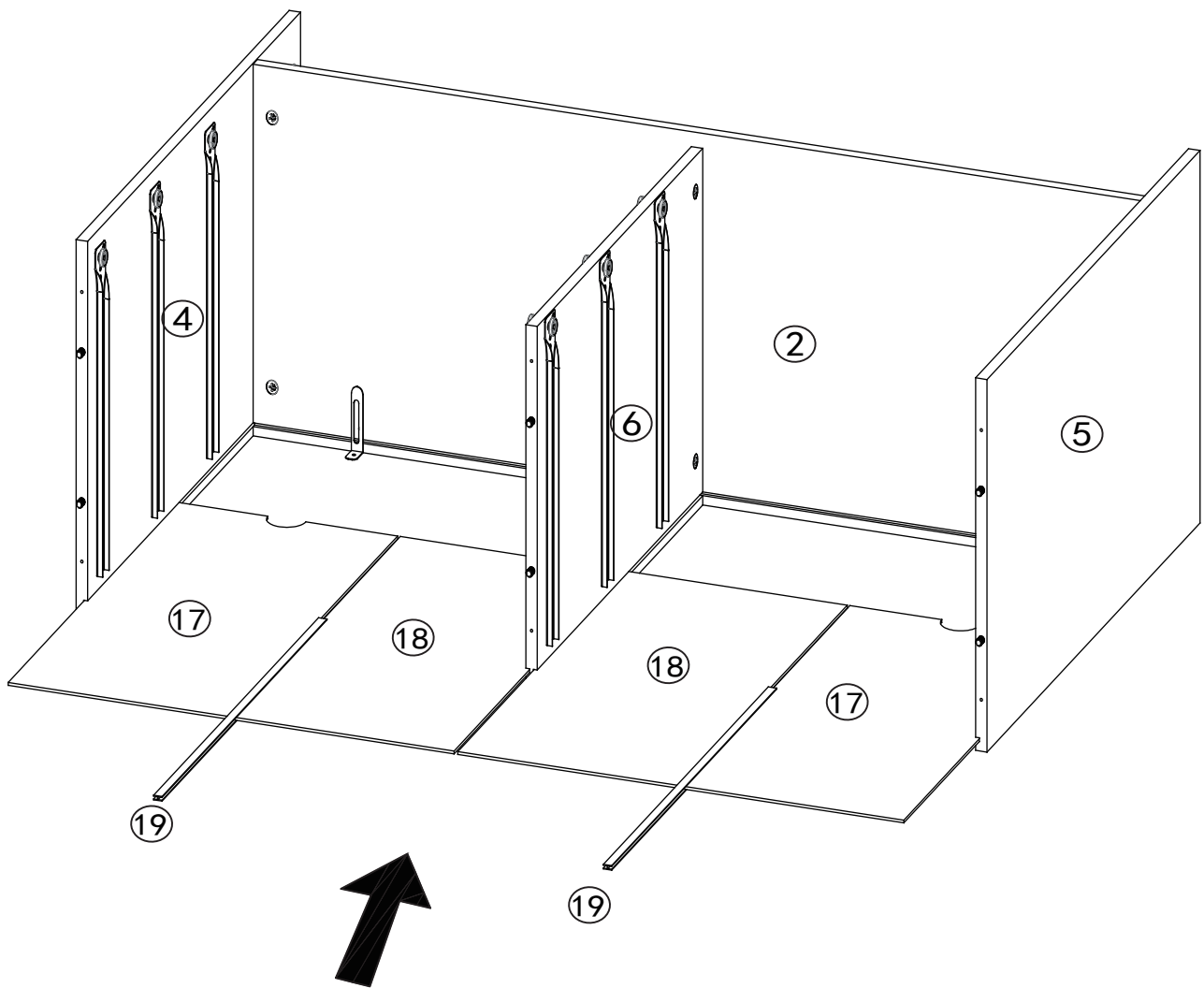

13

Φ4 x 35

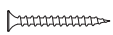

D X 6

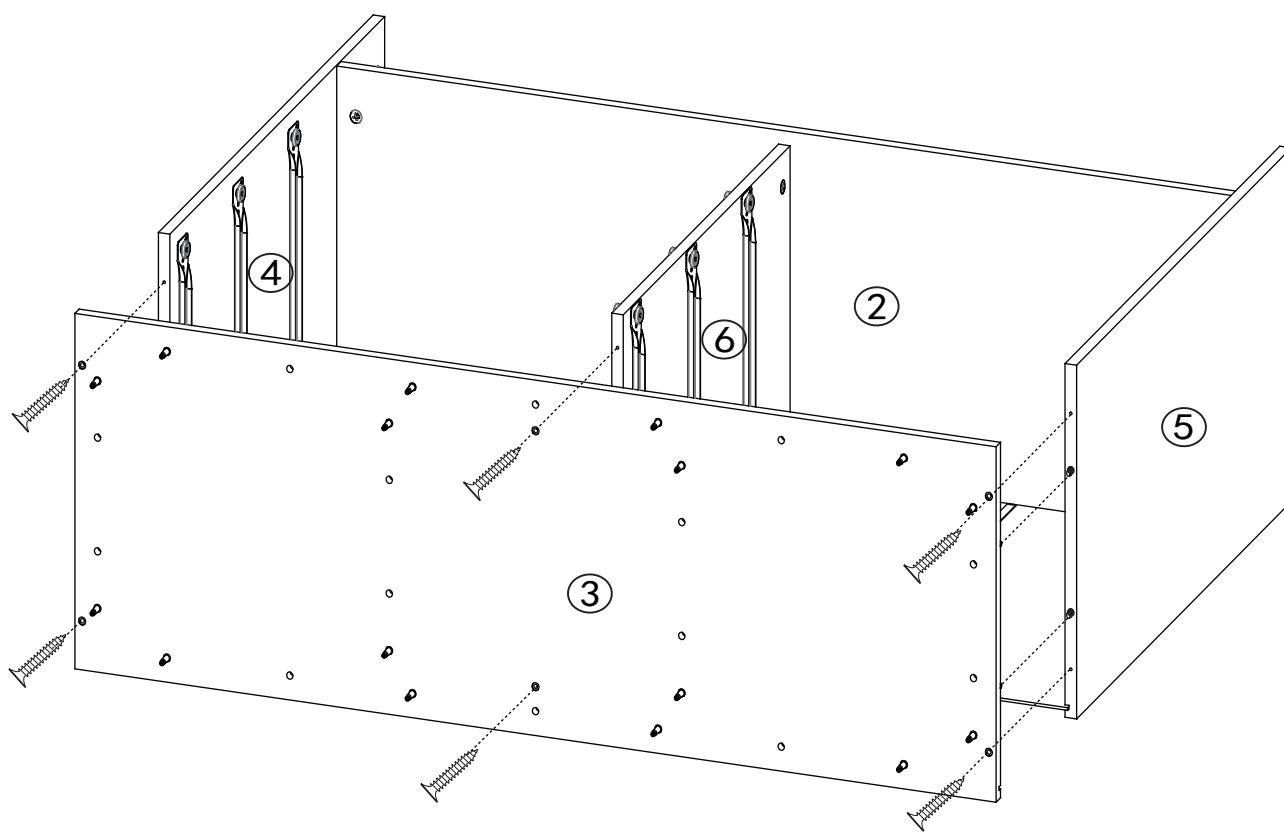

D X 6

14

$\Phi 15 \times 9.6$



B x 8

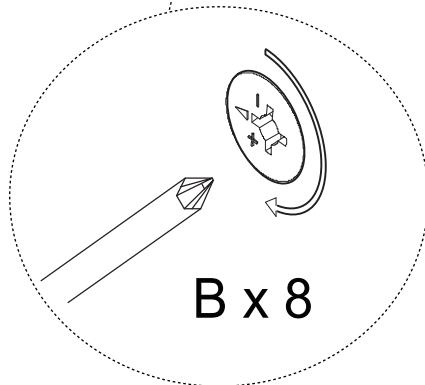
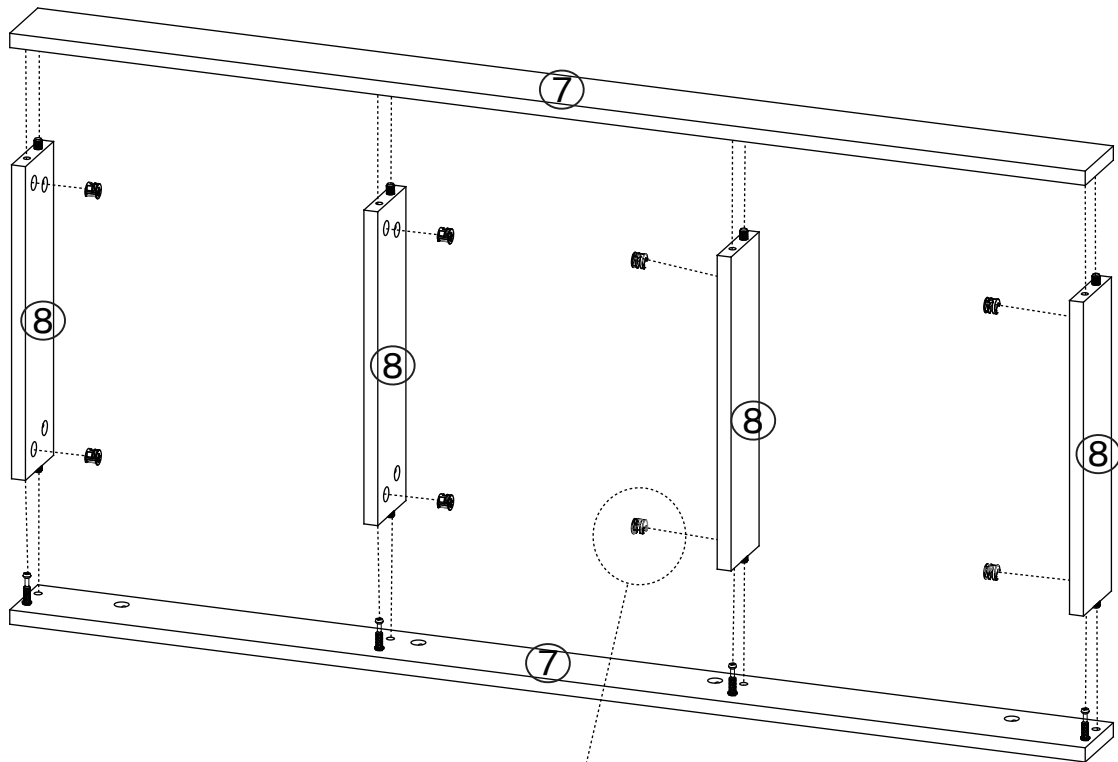



15

Φ 15\*9.6

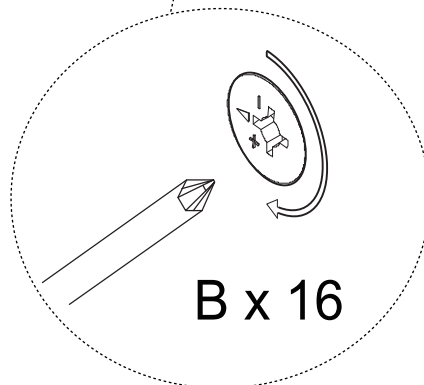
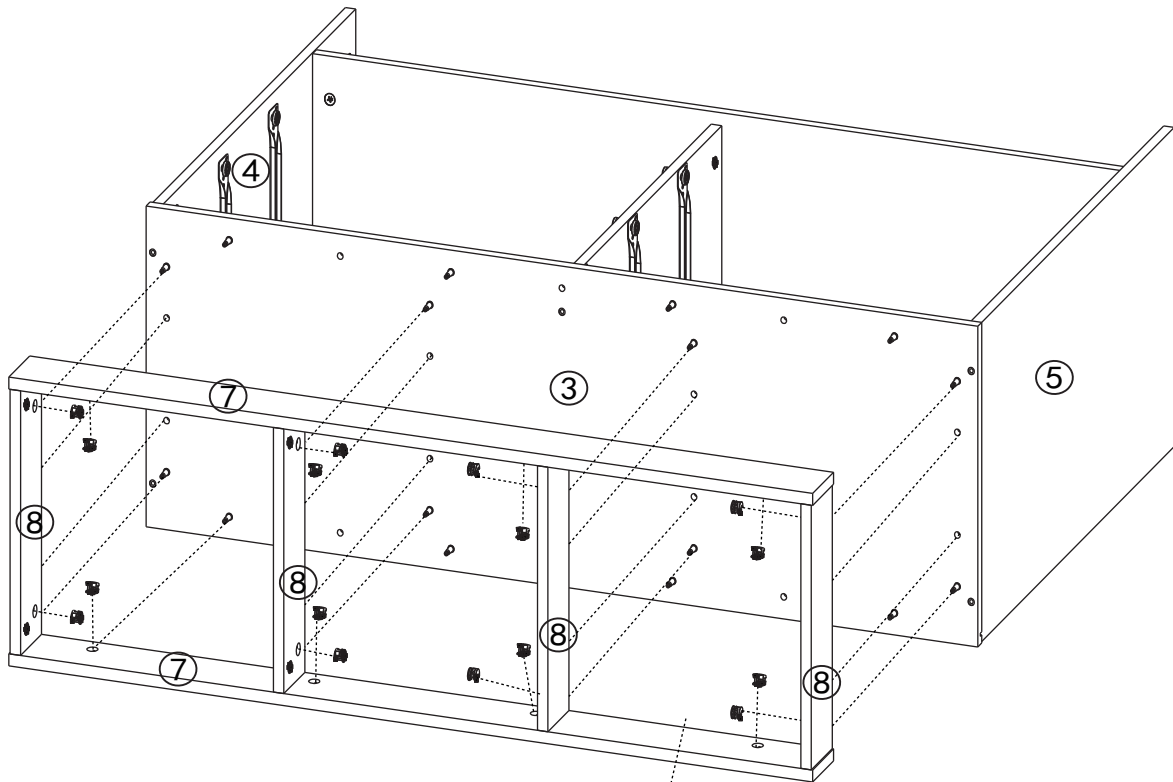

B X 16



**16**  $\Phi 15*9.6$   
  
B X 4

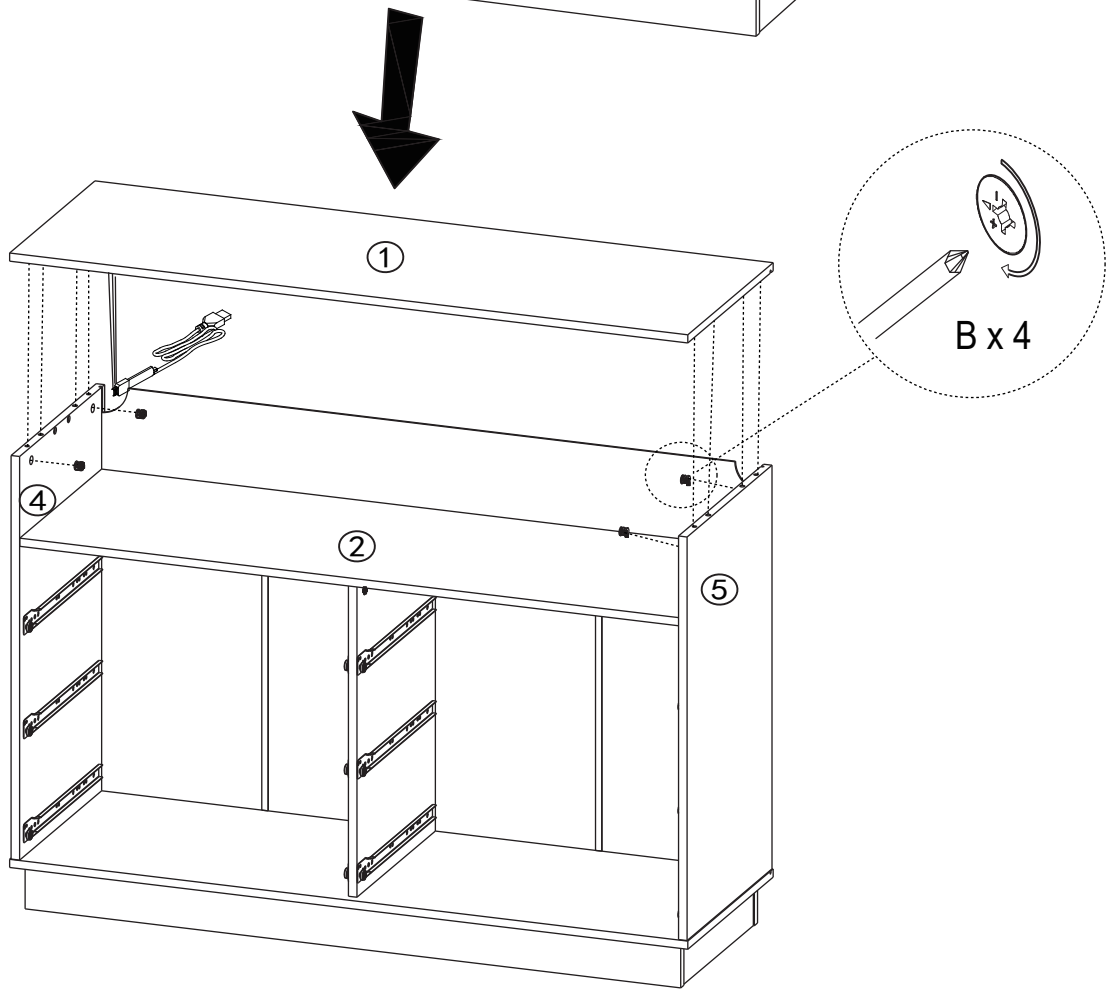
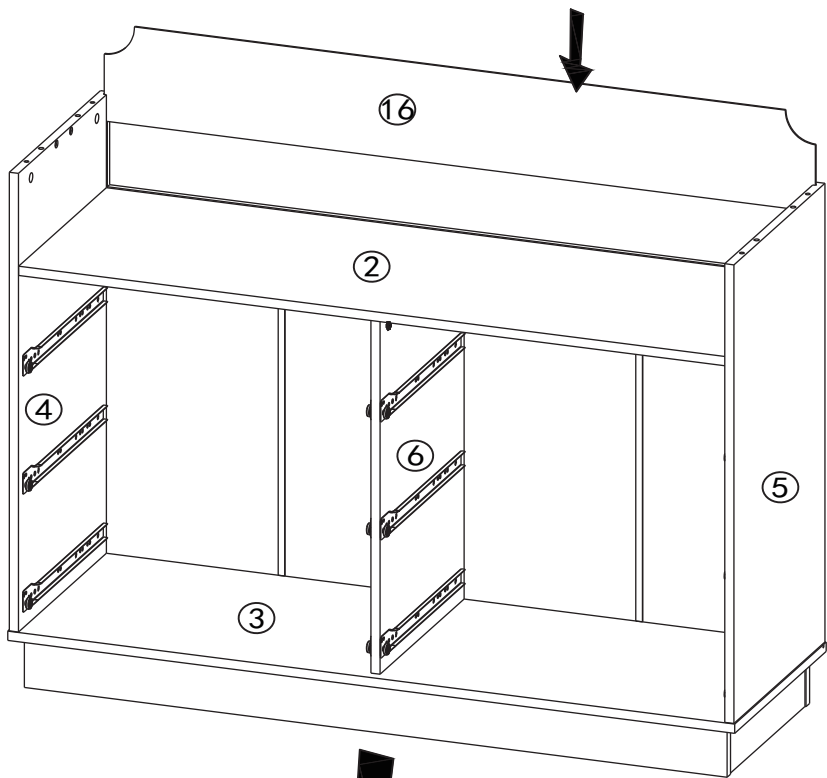

17

M6\*12



L X 4

L X 4

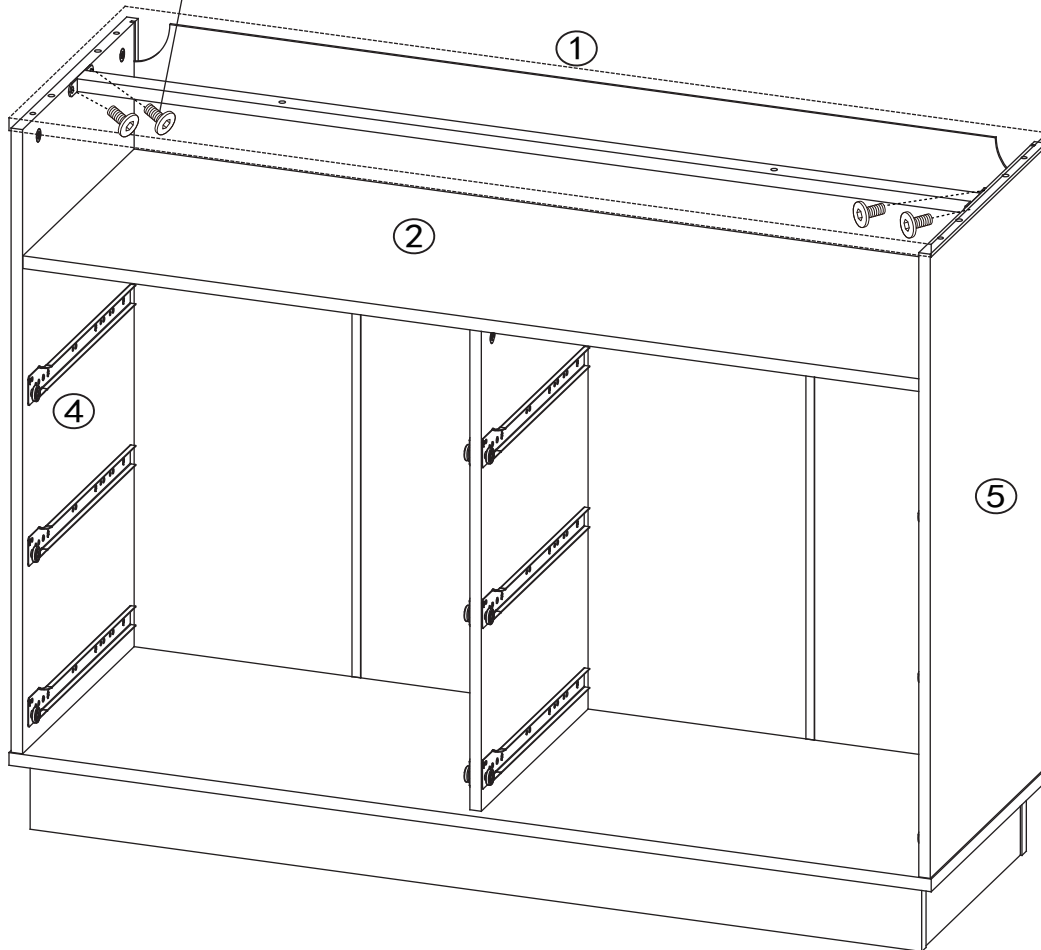

18



M3.5\*16

I X 6

Ø7\*35



M4\*35



K X 2

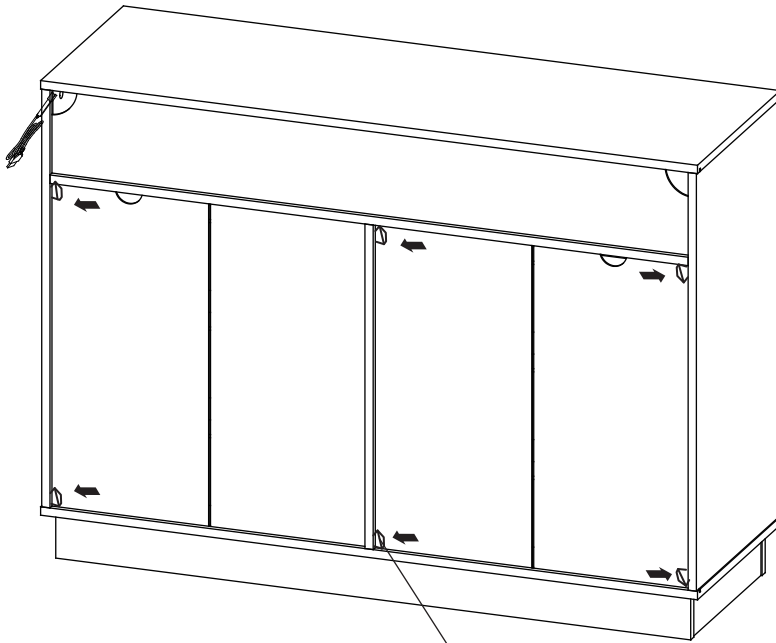

I X 6

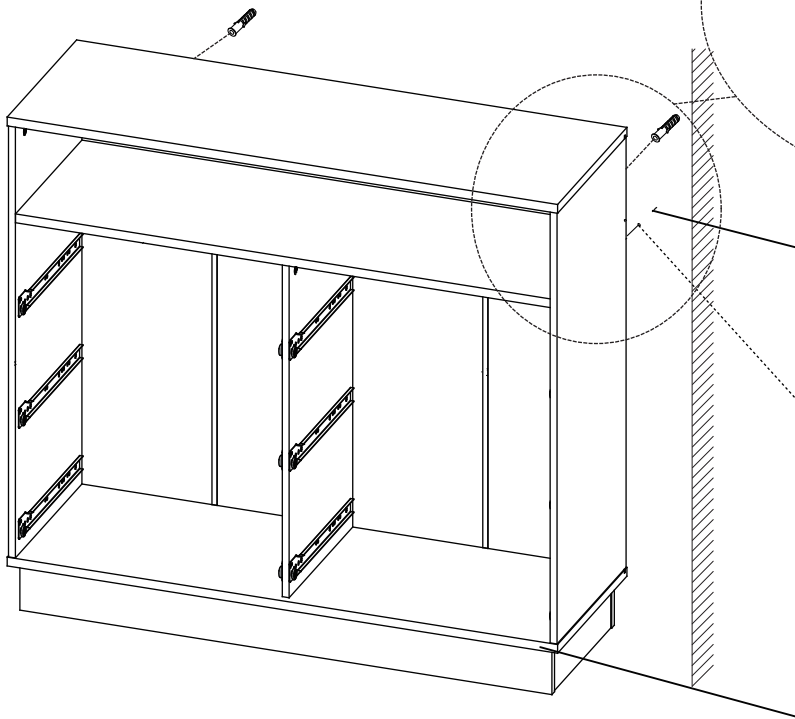

Wall

K X 2

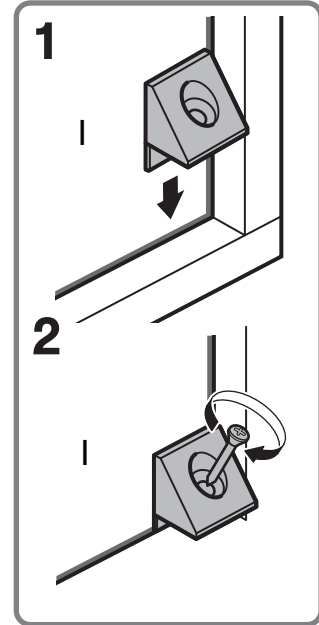

19

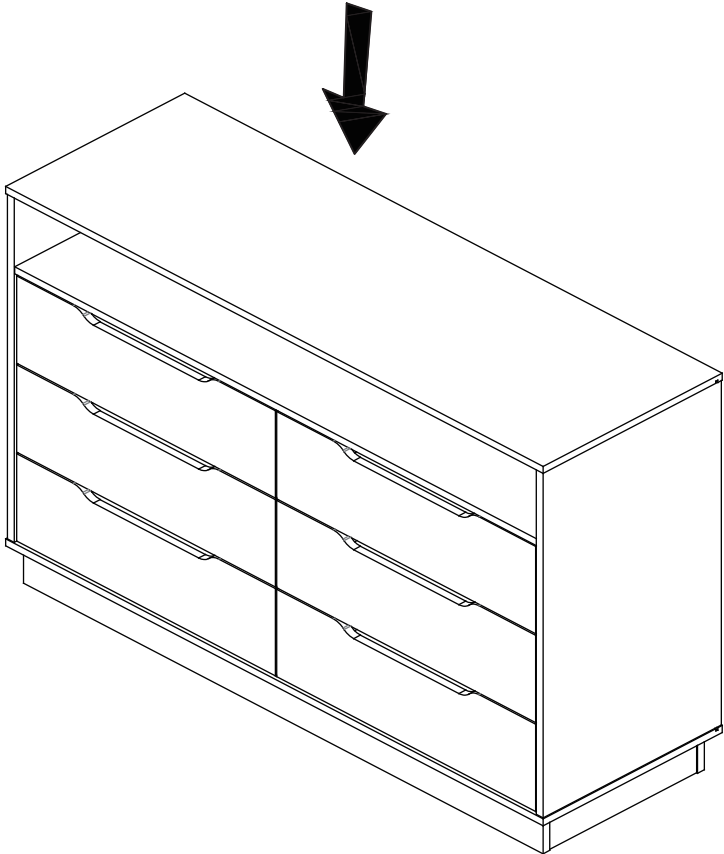
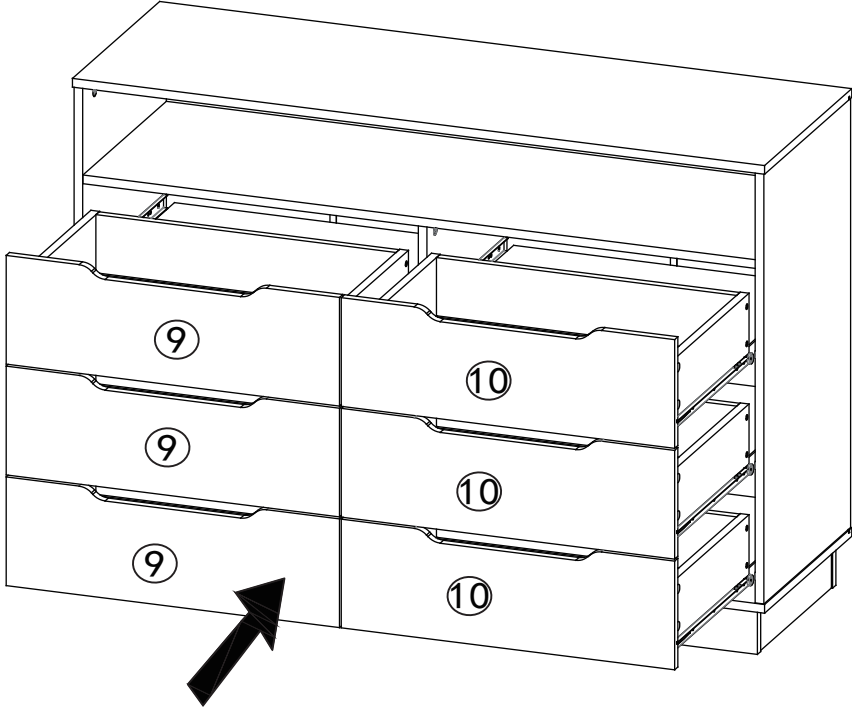

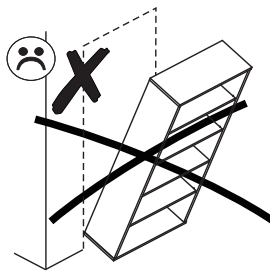
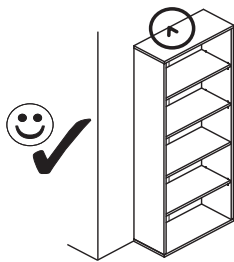

PL.

UWAGA! Mebel należy trwale zamocować do ściany, aby uniknąć ryzyka związanego z przewróceniem się mebla. W paczce znajdują się elementy mocujące odpowiednie wyłącznie do ścian betonowych lub z pełnej cegły.

Jeśli Twoja ściana wykonana jest z innego materiału lub nie masz pewności co do budowy tej ściany, skonsultuj się w kwestii montażu ze specjalistą.

D.

ACHTUNG! Um alle mit dem Umkippen des Möbels verbundenen Risiken auszuschließen, muss das Möbel fest an der Wand verankert werden. Die im Paket enthaltenen Beschläge für die Wandbefestigung sind ausschließlich für Wände aus Beton oder Vollziegeln geeignet. Sollten die heimischen Wände aus anderem Baumaterial bestehen oder sollte es Zweifel in Hinsicht auf dieses Baumaterial geben, bitte eine Fachkraft zu Rate ziehen.

FR.

ATTENTION! Ce meuble doit être fixé en permanence au mur pour éviter les risques de chute. L'ensemble comprend des moyens de fixation adaptés uniquement aux murs de béton ou de brique. Si votre mur est fait d'un matériau différent ou si vous êtes incertain quant à la construction du mur, consultez un spécialiste.

I.

ATTENZIONE! Il mobile deve essere permanentemente fissato alla parete per evitare i rischi derivanti da un ribaltamento del mobile. La confezione contiene solo elementi di fissaggio adatti per pareti in calcestruzzo o in laterizio pieno. Se la vostra parete è realizzata in materiale diverso o avete dubbi sulla costruzione della parete, consultare uno specialista per un montaggio corretto.

RU.

ПРИМЕЧАНИЕ! Эту мебель необходимо всегда прикреплять к стене, чтобы избежать рисков, связанных с переворотом мебели. В пакете находятся крепительные элементы, которые подходят исключительно к бетонным стенам или из целого кирпича. Если стена изготовлена из другого материала или Вы не уверены относительно строения стены, проконсультируйтесь относительно монтажа со специалистом.

EN.

WARNING! To prevent this furniture from tripping over, fix it to the wall permanently. The package includes fastening elements only suitable for concrete or full-brick walls. If your wall is made of a different material or you are unsure as to the construction of the wall, please consult a specialist regarding installation.

SK.

POZOR! Nábytok musí byť trvalo pripevnený k stene tak, aby sa zamedzilo riziku prevrátenia. V balíku sa nachádzajú upevňovacie komponenty výlučne pre betónové steny alebo steny z plnej tehly. Ak je Vaša stena z iného materiálu alebo ak si nie ste istí, z čoho je stena vyhotovená, vyžiadajte si odbornú pomoc.

CZ.

POZOR! Nábytek je nutné pevně připevnit ke zdi, abychom se vyhnuli riziku spojenému s jeho převrnutím. V balíčku se nacházejí připevňující prvky vhodné výhradně do betonových zdí nebo zdí z plných cihel. Pokud jsou Vaše zdi zhotoveny z jiného materiálu nebo si nejste jejich konstrukcí jisti, konzultujte otázku montáže se specialistou.

RO.

ATENȚIE! Mobila trebuie ancorată permanent în perete pentru a evita riscul de răsturnare a mobilei. Pachetul conține elementele de fixare potrivite numai pentru pereții din beton sau din cărămidă solidă. Dacă peretele Dvs. este realizat dintr-un alt material sau nu sunteți sigur care este structura peretelui, consultați un specialist în privința montajului.

NL.

OPMERKING! De meubelen moeten permanent aan de muur worden bevestigd om te voorkomen dat de meubelen kantelen. Het pakket bevat bevestigingselementen die alleen geschikt zijn voor betonnen of massieve bakstenen muren. Als uw muur van een ander materiaal is gemaakt of als u niet zeker bent over de constructie van deze muur, raadpleeg dan een specialist voor de installatie.

TR.

DİKKAT! Devrilmeye riskini önlemek için mobilya duvara sabitlenmelidir. Pakette, sadece beton veya tam tuğla duvarlara uygun sabitleme elemanları bulunmaktadır. Eğer duvarınız başka bir malzeme ile yapıldıysa veya duvar yapısından emin değilseniz, montaj konusunda bir uzmana danışınız.

AR.  
ملاحظة!

يجب تثبيت الأثاث بإحكام إلى الحائط أو الجدار لتجنب خطر إنقلابه. تحتوي العلبه على مسامير التثبيت التي تناسب الجدران الخرسانية أو الطوب. إذا كان جدارك مصنوعاً من مادة مختلفة أو لم تكن متأكداً من مادة بنائه اسأل المتخصص عن كيفية التثبيت.

E.

¡ATENCIÓN! El mueble debe ser fijado permanentemente a la pared para evitar el riesgo relacionado con el vuelco del mueble. En el paquete hay elementos de fijación adecuados solo para paredes de hormigón o de ladrillo entero. Si su pared está hecha de otro material o no está seguro sobre la construcción de esta pared, consulte el montaje con un especialista.

CN.

注意！本家具需要固定在墙上以免倒塌。本包所含有的固定部件仅适用于混凝土墙及整砖墙。欲使用在其他墙体或不确定墙体时，请向专家询问安装方式。

HR.

NAPOMENA! Namještaj mora biti trajno pričvršćen za zid, kako bi se izbjegao rizik od njegova prevrtanja. U paketu se nalaze elementi za pričvršćivanje prikladni isključivo za betonske zidove ili punu ciglu. Ako je Vaš zid izrađen od drugog materijala ili niste sigurni od čega je napravljen Vaš zid, konzultirajte se sa stručnjakom u vezi sa montažom.

SLO.

POZOR! Pohištvo trajno pritrdite na steno, da preprečite tveganje, da se prevrne. V paketu so pritriljni elementi, ki so ustrezni izključno za betonske stene in za stene iz polne opeke. Če je vaša stena izdelana iz drugih materialov ali niste gotovi glede konstrukcije stene, se o montaži posvetujte s strokovnjakom.

HU.

FIGYELEM! Rögzítse a bútortakat a falhoz, hogy elkerülje a bútor felborulásának kockázatát. A készletben kizárólag beton- vagy téglafalhoz használható kötőelemek találhatók. Ha a fal más anyagból készült, vagy ha nem tudja, milyen falak találhatók otthonában, forduljon szakemberhez.

**DE:** Wenn Sie die Lichter nicht erfolgreich arbeiten lassen können, überprüfen Sie bitte die Folgendes:

1. Lassen Sie die Fernbedienung nicht zu weit vom Empfänger entfernt sein. Es gibt kein Hindernis zwischen ihnen.

2. Bitte beachten Sie, dass die Fernbedienung für den Transport keine Batterien enthält. Das Batteriemodell lautet: CR2025 3V

**FR:** Si vous ne parvenez pas à faire fonctionner les lumières correctement, veuillez vérifier les points suivants?:

1. Ne laissez pas la télécommande être trop éloignée du récepteur. Il n'y a aucun obstacle entre eux.

2. Veuillez noter que la télécommande ne contient pas de piles pour le transport. Le modèle de batterie est?: CR2025 3V

**UK:** If you can't make the lights work successfully, please check the following:

1. Don't let the remote control be too far from the receiver. There is no obstacle between them.

2. Please note that the remote control does not contain batteries for transportation. The battery model is: CR2025 3V

[DE]

HINWEIS: Der Akku in der Fernbedienung erfordert, dass Sie Sie selbst kaufen und installieren.

Modell: CR2025 3V

[EN]

NOTE: The battery in the remote control requires you to purchase and install it yourself.

Model: CR2025 3V

[FR]

REMARQUE : La pile de la télécommande est requise, que vous les achetez et les installez vous-même.

Modèle : CR2025 3V

[IT]









NOTA: la batteria del telecomando richiede, che li acquisti e li installi tu stesso.

Modello: CR2025 3V

[ES]

NOTA: La batería del control remoto requiere, que los compre e instale usted mismo.

Modelo: CR2025 3V

<p>①</p>  <p>A photograph of a black remote control with its battery cover open. The cover is hinged on the right side. A white arrow points from the cover towards the right.</p>	<p>②</p>  <p>A photograph of the black battery cover, showing the internal battery compartment and the hinge mechanism.</p>
<p>③</p>  <p>A photograph of the battery cover with the hinge mechanism on the right side. A white arrow points from the cover towards the right.</p>	<p>④</p>  <p>A photograph showing a small gold coin and the hinge mechanism. A white arrow points downwards.</p>
<p>⑤</p>  <p>A photograph showing the gold coin and the hinge mechanism. The coin is positioned to be inserted into the hinge.</p>	<p>⑥</p>  <p>A photograph showing the gold coin inserted into the hinge mechanism. The text "CR2025 3V" is visible below the image.</p>
<p>⑦</p>  <p>A photograph showing the gold coin inserted into the hinge mechanism. A white arrow points from the cover towards the left.</p>	<p>⑧</p>  <p>A photograph of the battery cover with the coin inserted into the hinge mechanism.</p>



# Certificate of Compliance

**Certificate Number: ZHT-240411021C**

**Certificate's Holder** : Shenzhen xu xing technology co., LTD  
**Zertifikatsinhaber** Floor 3, building C, Huaze hi tech Industrial Park, Shiyan street,  
Bao'an District, Shenzhen

**Manufacturer** : Shenzhen xu xing technology co., LTD  
**Hersteller** Floor 3, building C, Huaze hi tech Industrial Park, Shiyan street,  
Bao'an District, Shenzhen

**Trade Mark** : /  
**Warenzeichen**

**Product** : Colorful light strip  
**Produkt**

**Model(s)** : XX5050RGB-60D  
**Modell** XX5050RGB-30D, XX5050RGB-72D, XX5050RGB-96D,  
XX5050RGB-120D, XX2835-120D, XX2835-60D, XX2835-150D,  
XX2835-240D, XX2835-W, Y-120D, XX2835-W, Y-60D, XX2025-120D

**Test Standard** : EN IEC 55015:2019+A11:2020  
**Prüfnorm** EN IEC 61000-3-2:2019 + A1:2021  
EN 61000-3-3:2013 + A1:2019 + A2:2021  
EN IEC 61547:2023

**Test Report No.** : ZHT-240411021E  
**Bericht Nr**

This Attestation of Compliance is issued on a voluntary basis for electrical equipment below the voltage limits of EMC Directive 2014/30/EU. The essential requirements are fulfilled accordingly based on the technical specifications applicable at the time of issuance. It is only valid in connection with the test report.



The information of the certificate can be checked through [www.zht-lab.cn](http://www.zht-lab.cn).  
The CE mark which is shown on the certificate can only be used under the conditions that the products complete with all of the relevant Directives of EC Declaration of Conformity.  
The Manufacturer should be responsible for the internal production control so that the products complied with the essential requirements of the above mentioned Directive(s). Certificate holder must notify all changes to the original certification laboratory of Guangdong Zhonghan Testing Technology Co., Ltd.



**Guangdong Zhonghan Testing Technology Co., Ltd.**

**Address:** Room 104, Building 1, Yibaolai Industrial Park, Qiaotou Community, Fuhai Street, Bao'an District, Shenzhen, Guangdong, China

**Tel.:** +86-755-27782934 **Http://**[www.zht-lab.cn](http://www.zht-lab.cn) **E-mail:** [admin@zht-lab.cn](mailto:admin@zht-lab.cn)

Shenzhen ZKT Technology Co., Ltd.

1/F, No. 101, Building B, No. 6, Tangwei Community Industrial Avenue,  
Fuhai Street, Bao'an District, Shenzhen, China



# Certificate of Compliance

**Certificate Number: ZKT-250109L0779C**

**Certificate's Holder** : Shenzhen xu xing technology co., LTD  
Floor 3, building C, Huaze hi tech Industrial Park, Shiyan street,  
Bao'an District, Shenzhen

**Manufacturer** : Shenzhen xu xing technology co., LTD  
Floor 3, building C, Huaze hi tech Industrial Park, Shiyan street,  
Bao'an District, Shenzhen

**Trade Mark** : /

**Product** : Colorful light strip

**Model(s)** : XX5050RGB-60D  
XX5050RGB-30D, XX5050RGB-72D, XX5050RGB-96D,  
XX5050RGB-120D, XX2835-120D, XX2835-60D, XX2835-150D,  
XX2835-240D, XX2835-W, Y-120D, XX2835-W, Y-60D, XX2025-120D

**Test Standard** : BS EN IEC 55015:2019+A11:2020  
BS EN IEC 61547:2023  
BS EN IEC 61000-3-2:2019+A2:2024  
BS EN 61000-3-3:2013+A2:2021

This certificate of compliance is issued according to the UK legislation: Electromagnetic Compatibility Regulations 2016(S.I. 2016/1091), Referred to as the UK Electromagnetic Compatibility.

It confirms that the listed product complies with all essential requirements of the Electromagnetic Compatibility Regulations 2016 and applies only to the sample and its technical documentation submitted to Guangdong Shenzhen ZKT Technology Co., Ltd.(ZKT) for testing.

It is only valid in connection with the test report number: ZKT-250109L0779E.

So ZKT here by acknowledges that the Manufacturer may issue a COC apply the UKCA marketing in according with United Kingdom Union Rules.

After preparation of the necessary technical documentation (Which must be kept for up to 10 years after the product is placed on the GB market as well as the UK declaration of conformity, the required UKCA marking can be affixed on the product. Other relevant Regulations have to be observed.

**UK  
CA**



This Certificate of Conformity is based on single evaluation of the submitted sample(s) of the above mentioned product. It does not imply an assessment of the whole product and relevant Directives to be observed.