

# THE DOOR SWINGS OPEN TO THE RIGHT

THE PIVOT BE INSTALLED ON THE RIGHT OF THE DOOR OPENING

## Bifold Barn Door Hardware Kit Instruction Manual

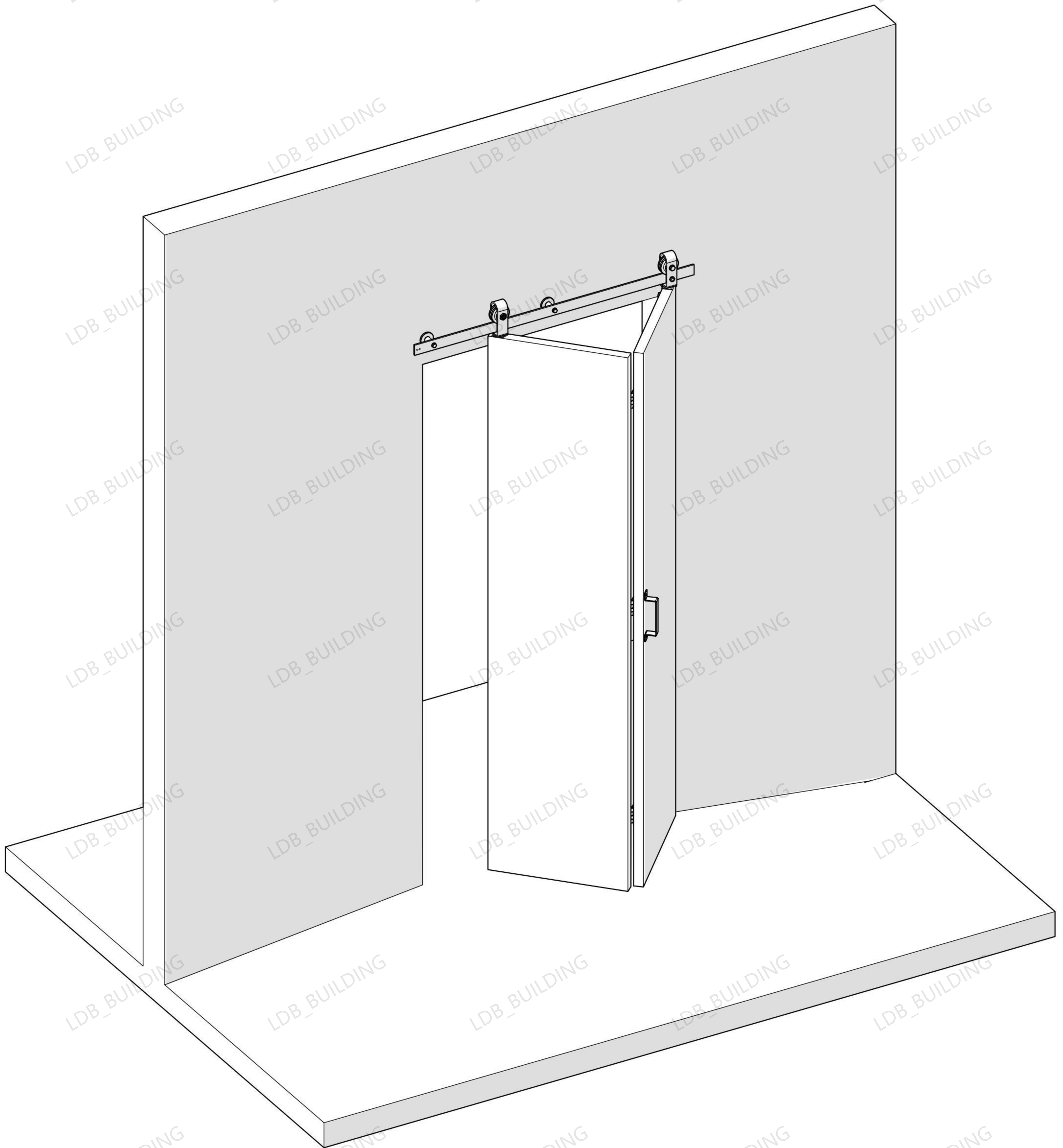

### OPERATION CAUTIONS:

Please read this installation guide carefully before installation.  
Please refer to the relevant content of this store for more product use.

# Hardware

**1 Rail(x1)** **Connector(x1)** **Track cap(x2)** **Wall Spacer Kit (x3)**

M6X10(x4)

**2 Anti-collision strip(x1)** **3 Fixed Roller(x1)** **M5x26(x1)** **Fixed Roller Lock Bracket(x1)**

(x2)

**4 Adjustable Roller(x1)** **5 Bottom Pivot Plate & Sleeve** **Ø8(x4)** **6 Bi-Fold Door Butt Hinges(x3)**

(x1) (x1) **ST4.2X32(x4)** **M6X25(X12)**

**7 Top Connector Plates (X2)** **8 Hex Key(x3)** **9 Handle(x1)**

**ST4.8X50(x4)**

## Number of Parts in Different Sizes

Single Door Width	number of doors	Track Length	door opening width = door width-2 inches
24inch	1	28inch	22inch
28inch	1	32inch	26inch
30inch	1	34inch	28inch
32inch	1	36inch	30inch
36inch	1	40inch	34inch
40inch	1	44inch	38inch

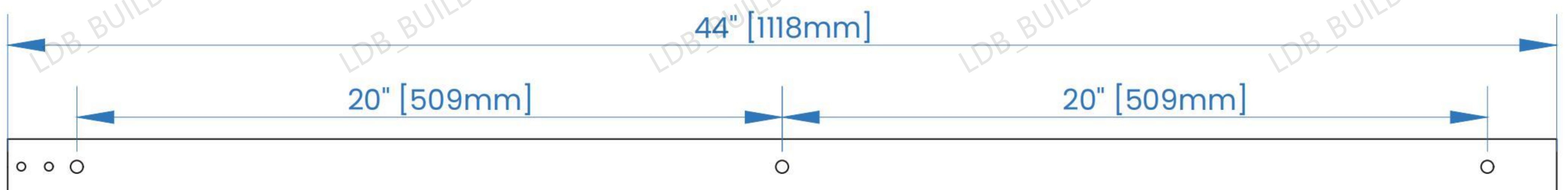
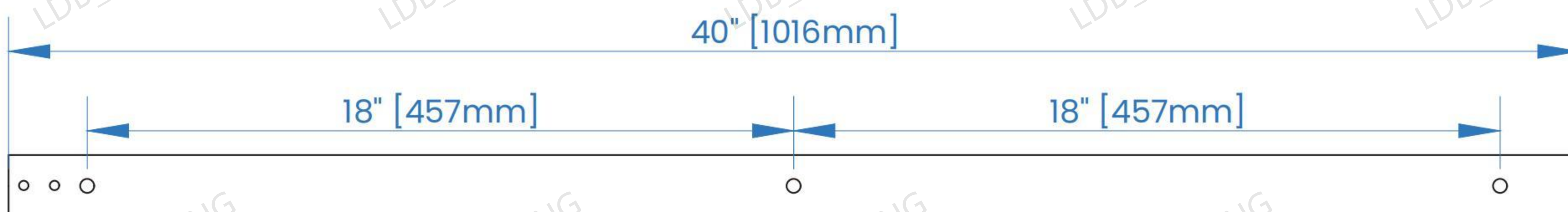
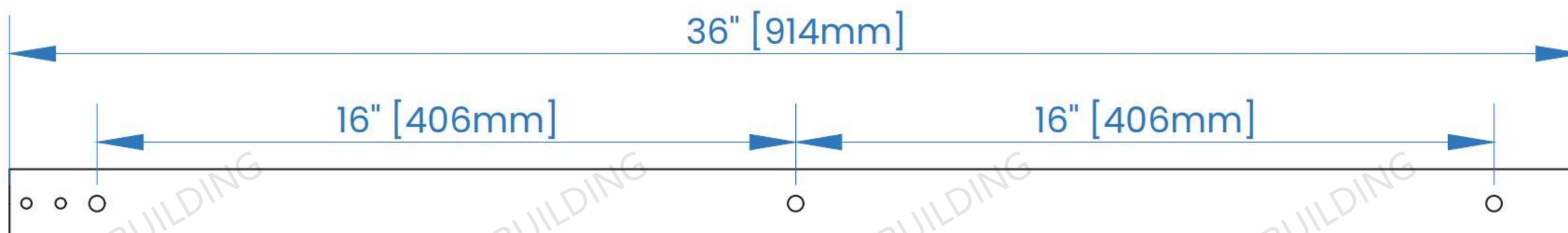
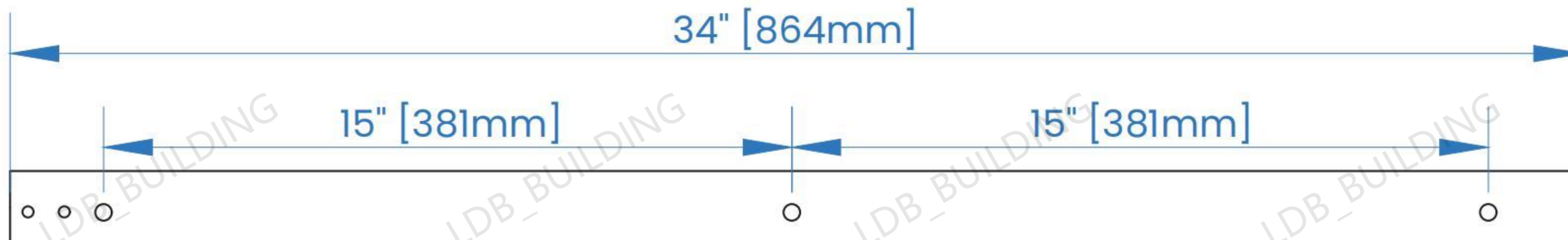
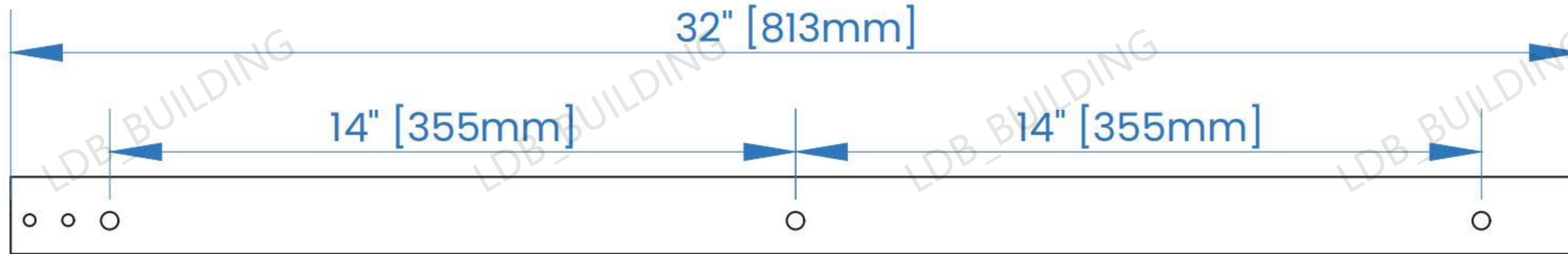
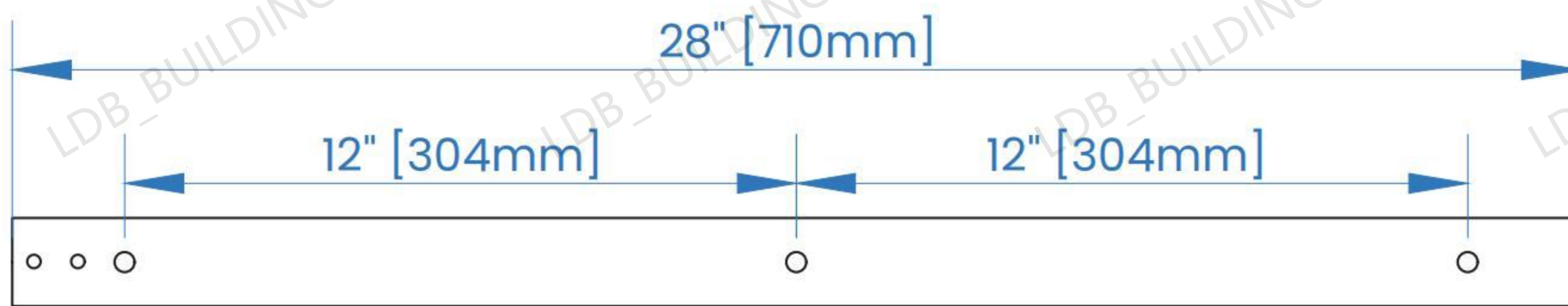

## Tools required



Speed Square



Pencil



Phillips  
Screwdriver



Tape



Wrench



Level



Drill

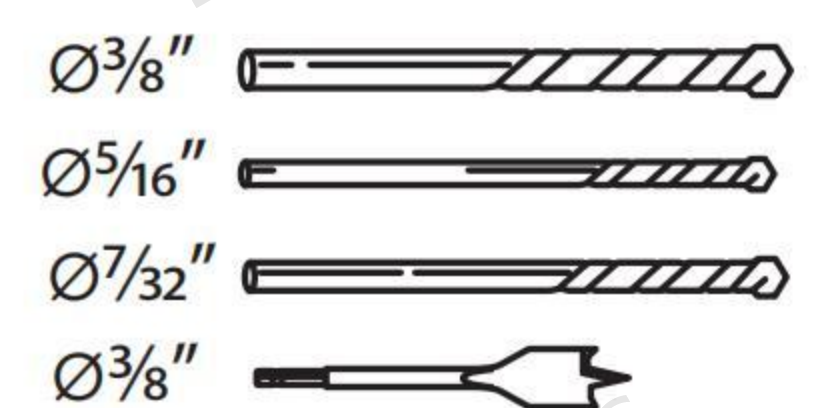

Drill Bit

## Measurements

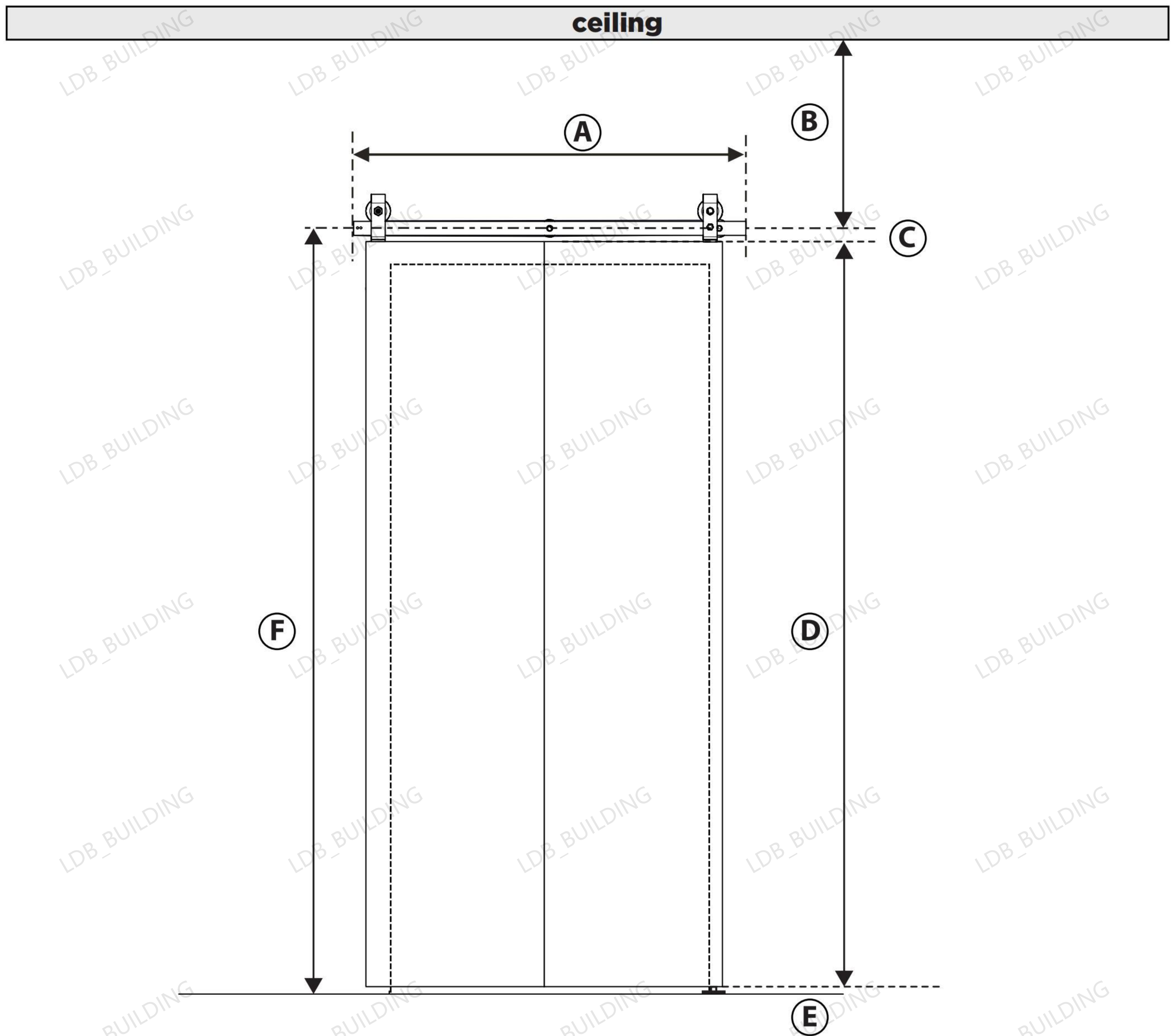

- A** Overall Rail length is 28inch,32inch,36inch,40inch,44inch.
- B** Minimum Distance from the rail hole to the ceiling is 6".
- C** Distance from the top of the door to the track center hole is  $1\frac{9}{16}$ ".
- D** Door height is  $L=84$ ".
- E** Distance from bottom of the door to the floor is  $\frac{3}{8}$ ".
- F** The height of the center line to the floor (measuring up from the floor) is  $85\frac{15}{16}$ "

## Important Notes

The following installation steps take a **44inch** track as an example. Please refer to the **[Number of Parts in Different Track Sizes]** for the quantity of accessories for different sizes of tracks

### **It is very important to determine whether you need to install a Header Board before you install the track.**

If you meet following situations, we highly recommended you using a header board (These situations might include but are not limited to)

- the wall is not concrete wall, such as drywall or other type wall
- there is a doorway trim (like a door frame or a skirting line)

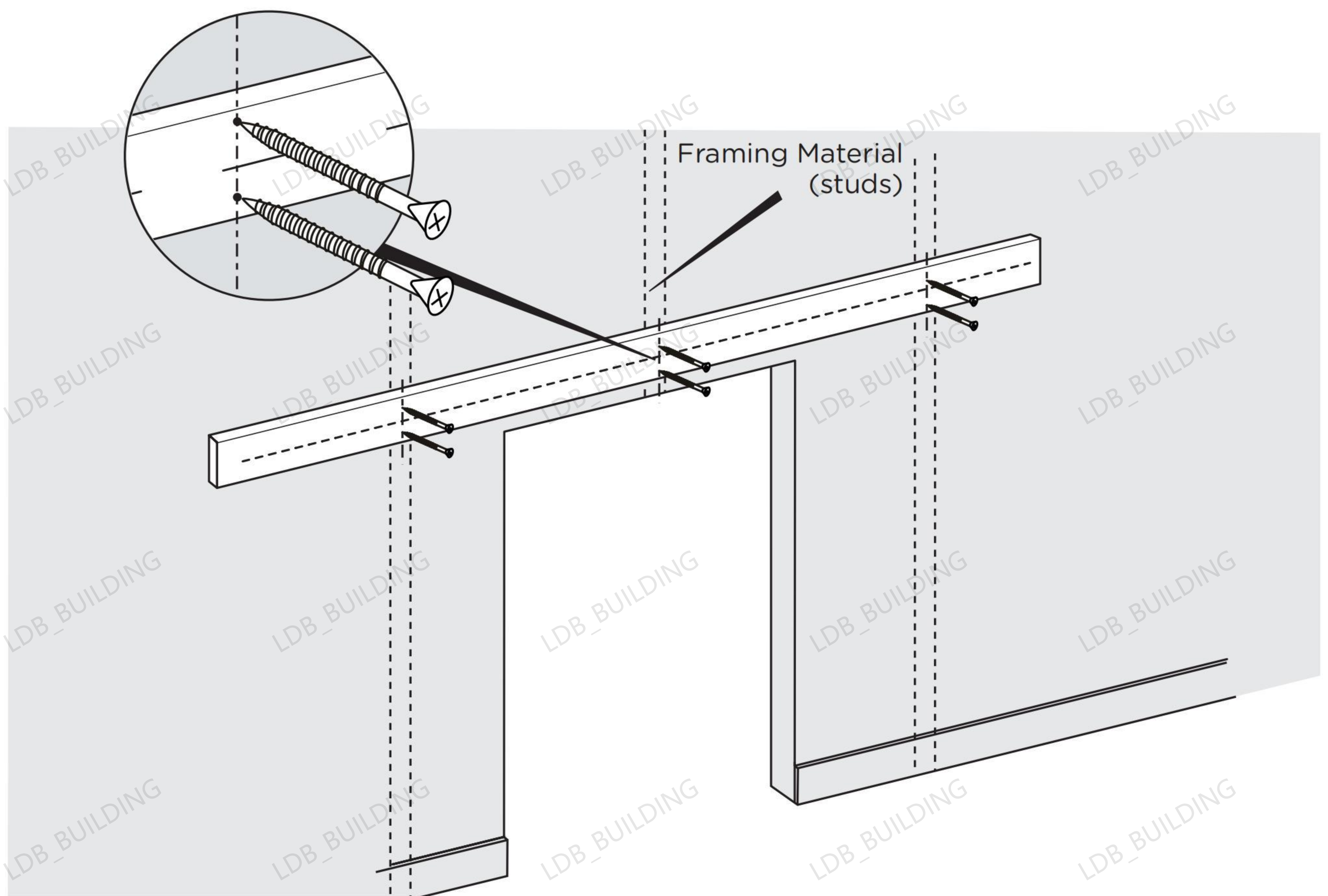

**Header Board requirements:**

**1" x 4" or 1" x 6" Size**

**Made of solid wood**

**Same length as your track length or longer**

**Attention: Header Board & the screws to install header board are not included. You can buy them online or offline.**

## Product Assembly

### Step-1(for single door)

1. Use a Level and Tape Measure to mark the center line of the track. As is shown in part in the picture above, the height of the center line to the floor (measuring up from the floor) is  $85 \frac{15}{16}$ ".
2. Position the track in place by the marked center line, ensuring it is level, and use the track as a template to mark mounting holes location for the track with a pencil
3. According to the marked track position, perpendicular to the track horizontal line, mark the position of the axle line of the fixed axis with a pencil. It is necessary that the distance from the axle line to the first hole position shall more than  $1 \frac{3}{16}$ " to ensure that the hole positions of the axle line and the holes of rail will not interfere with each other.

### See installation tip below.

Make sure that the door can cover the door opening during rotation before you mark the axle centre line.

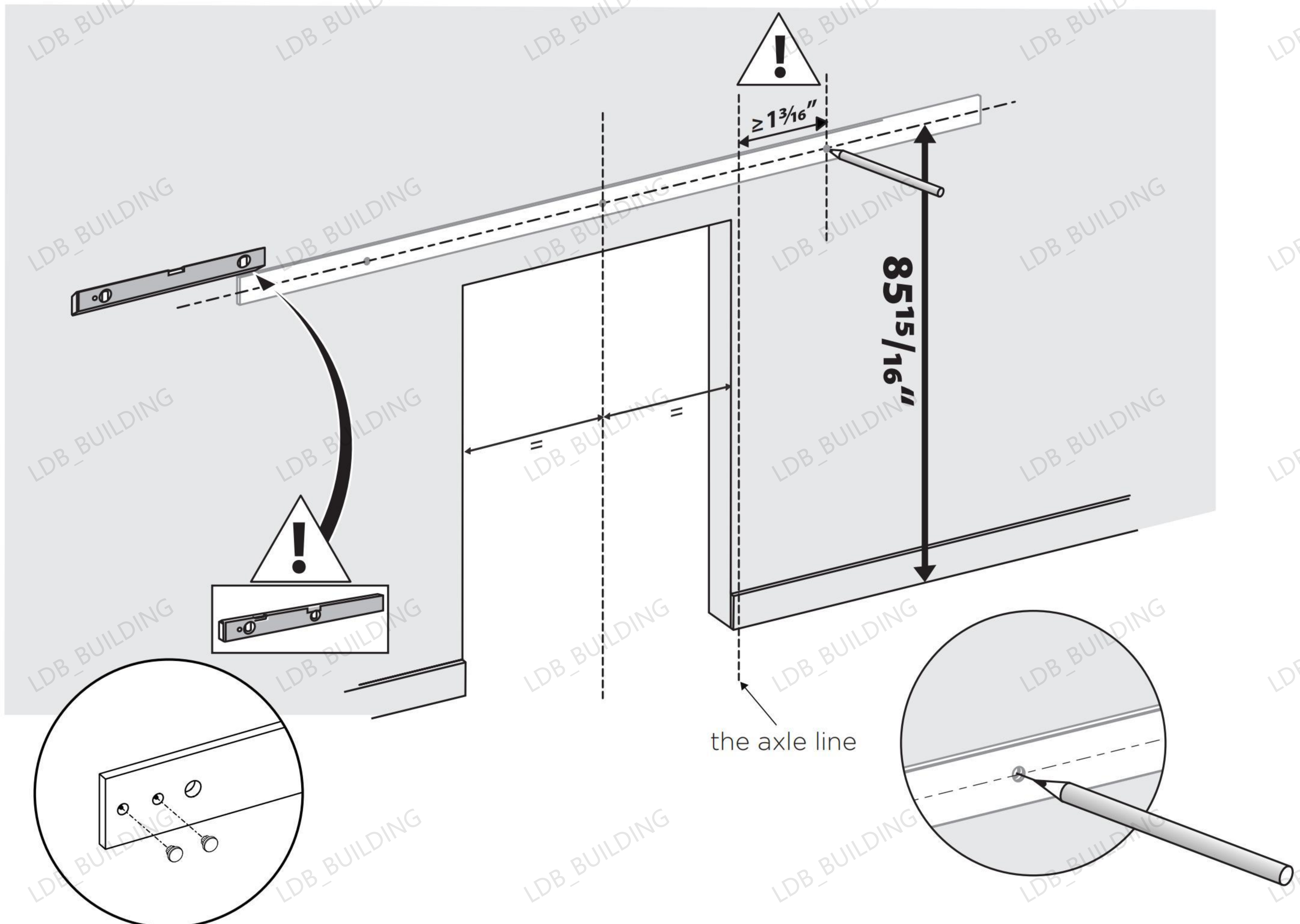

Only for single door

### INSTALLATION TIP:

To mark the holes more conveniently, you could install track with one end bolt without spacer, which helps fix one end of the track. And then you can move the free end to ensure the track level to mark mounting holes.

## Product Assembly

### Step-2(for double door)

**Note:** It is necessary that the distance from the axle line to the first hole position shall more than  $1\frac{3}{16}$ " to ensure that the hole positions of the axle line and the holes of rail will not interfere with each other.

The distances between 2 axle centre line are  $2L-2\frac{3}{4}$ " (L=length of single door)

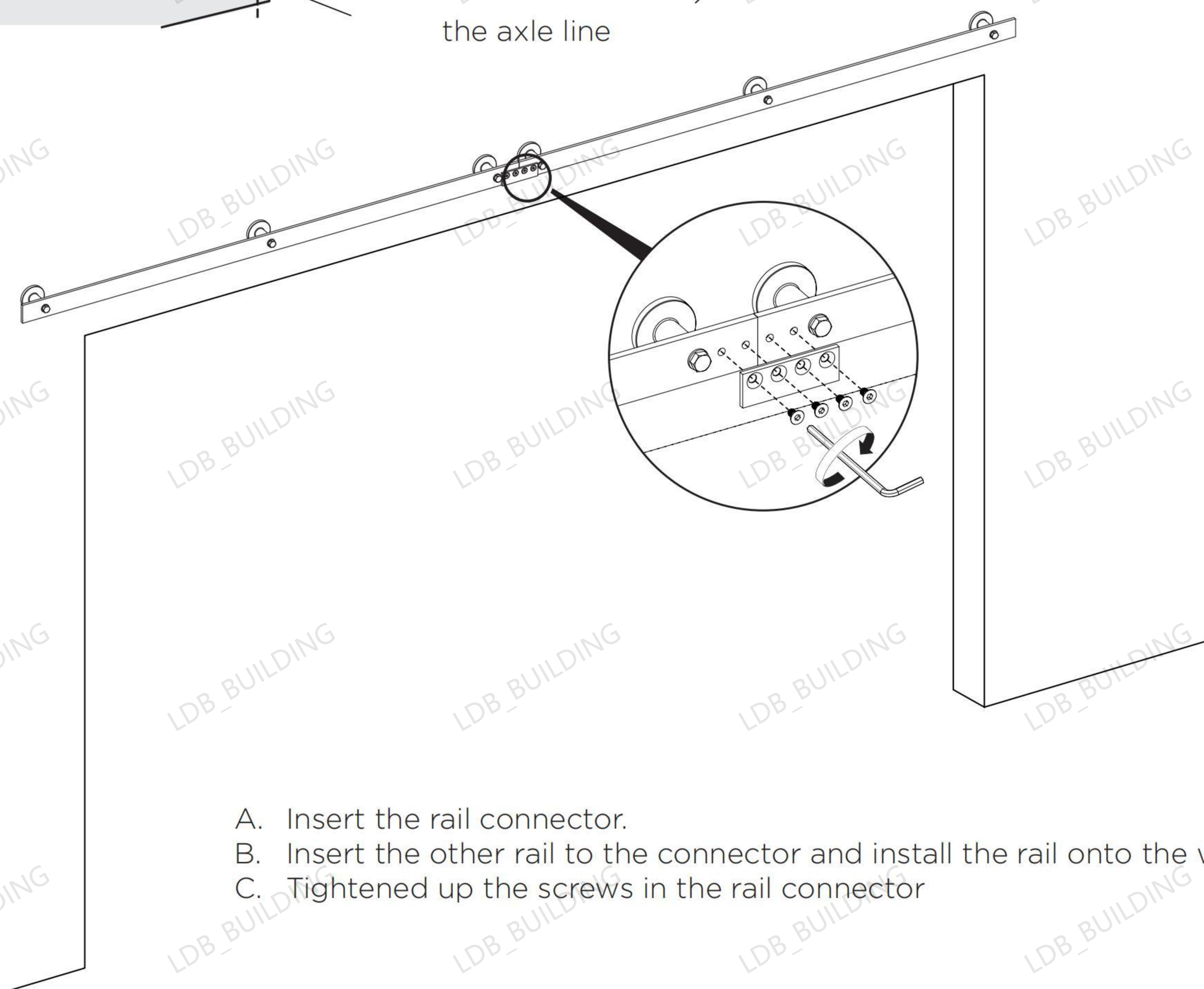
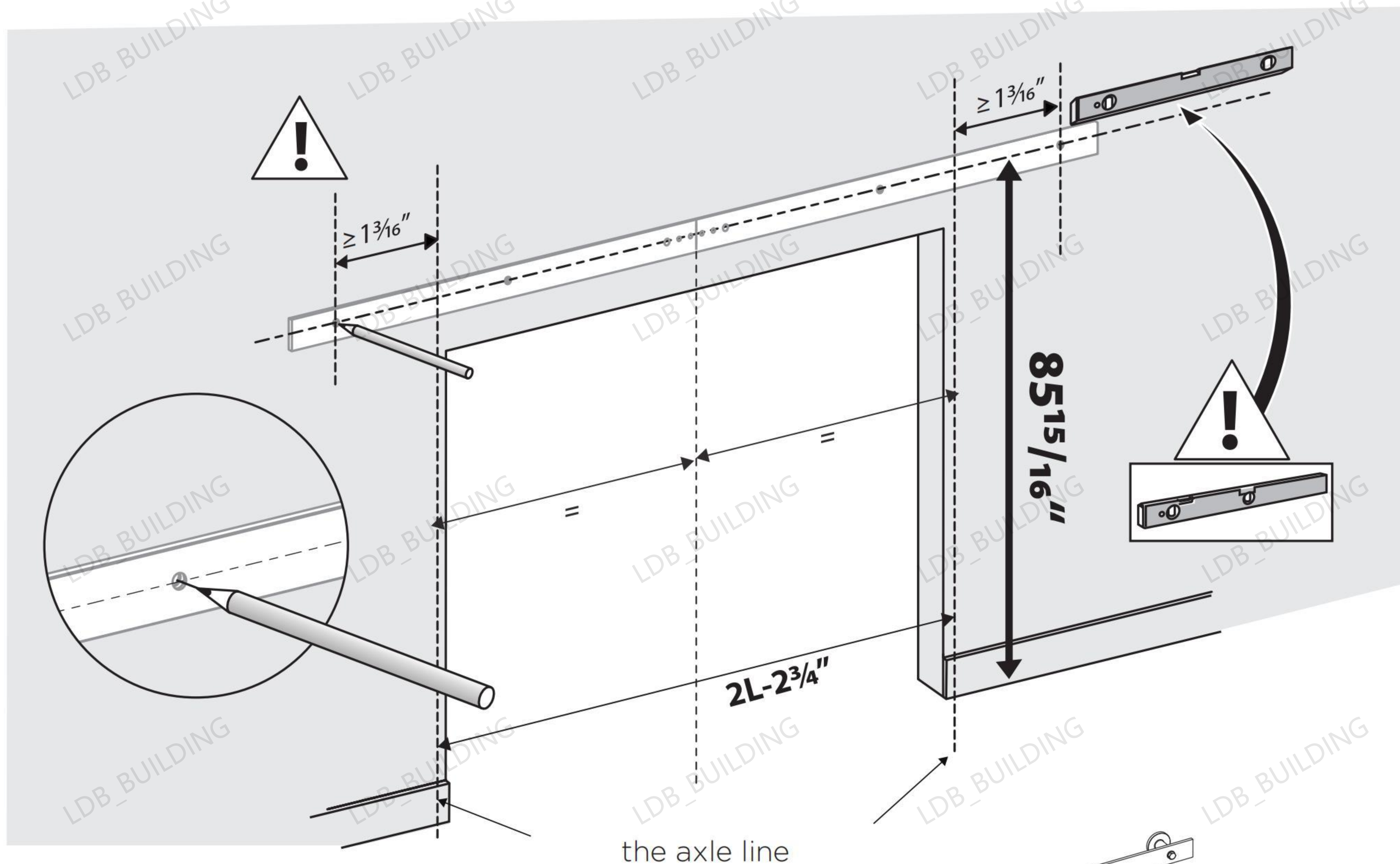

- Insert the rail connector.
- Insert the other rail to the connector and install the rail onto the wall.
- Tightened up the screws in the rail connector

# Product Assembly

## Step-2

Drill the marked holes with drill bits. Notice: The hole sizes of the 2 walls are different.

### A Concrete Wall

Drill the holes with  $\frac{3}{8}$ " drill bit

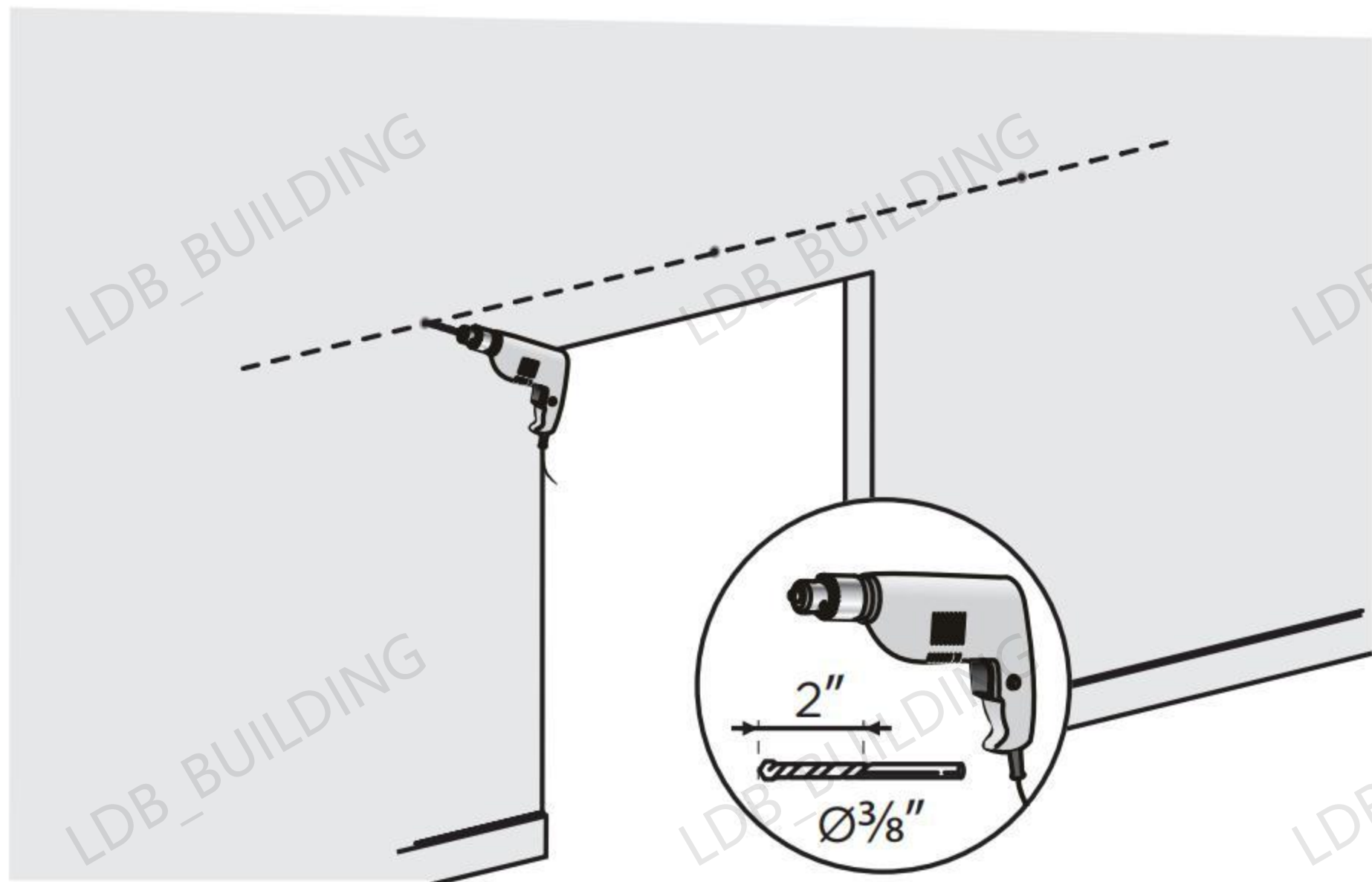

### B Drywall & Other Wall Type

Drill the pilot holes directly with the drill bit which is smaller than  $\frac{7}{32}$ "

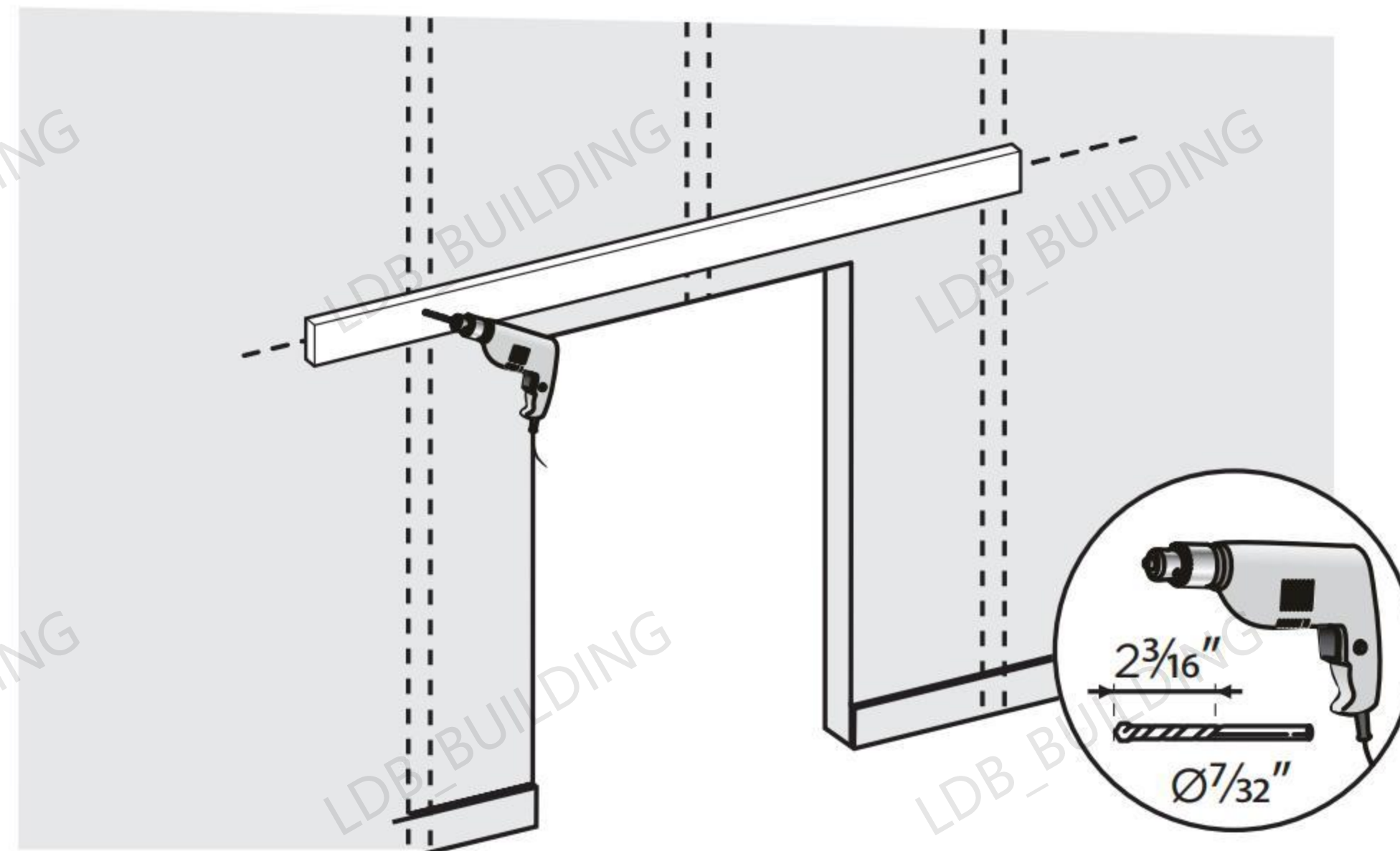

## Step-3

We provide 2 kinds of screws for you to install rail onto concrete wall or drywall.

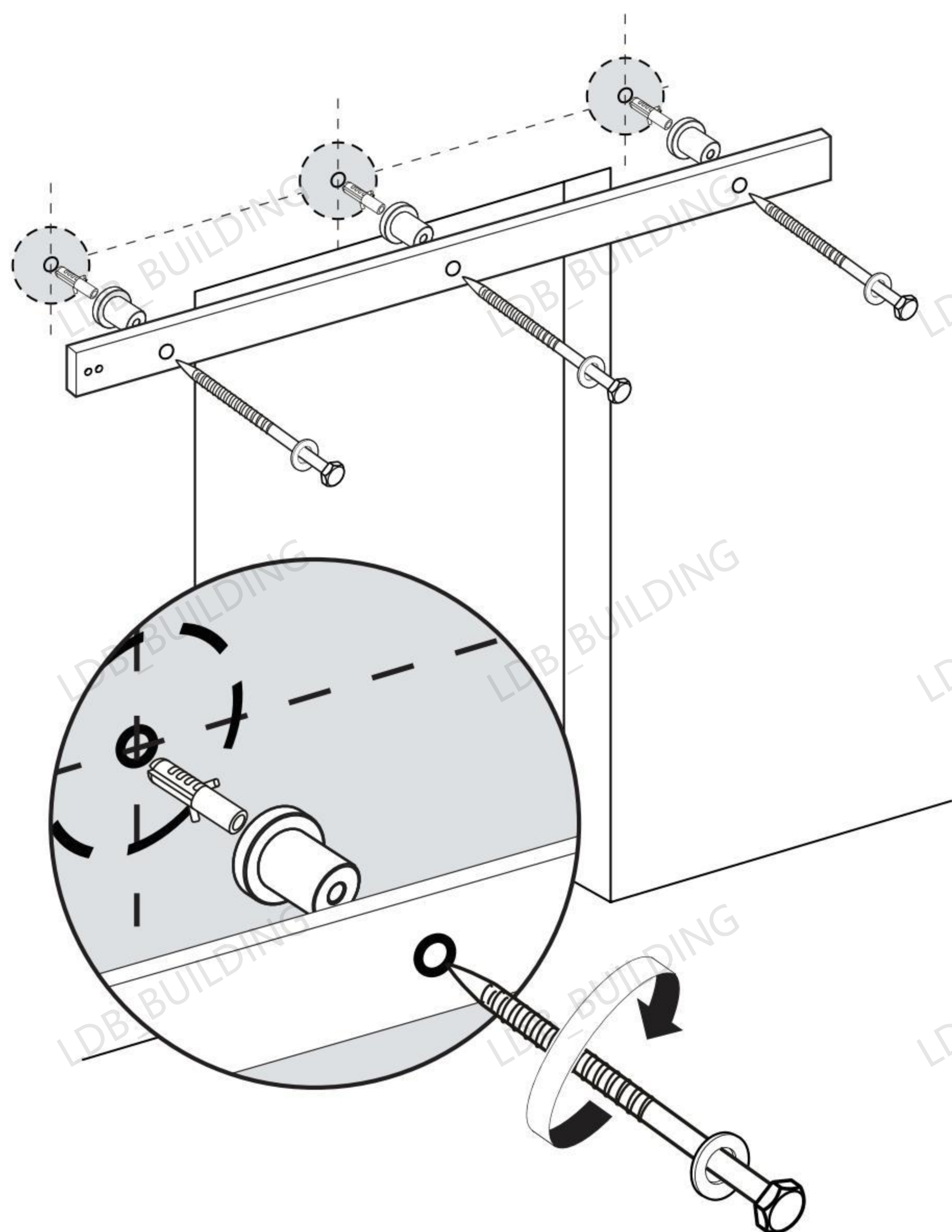

### A Concrete wall Installation.

Install the anchor to holes on the concrete wall first, then insert lag bolt to wall spacer and anchor.

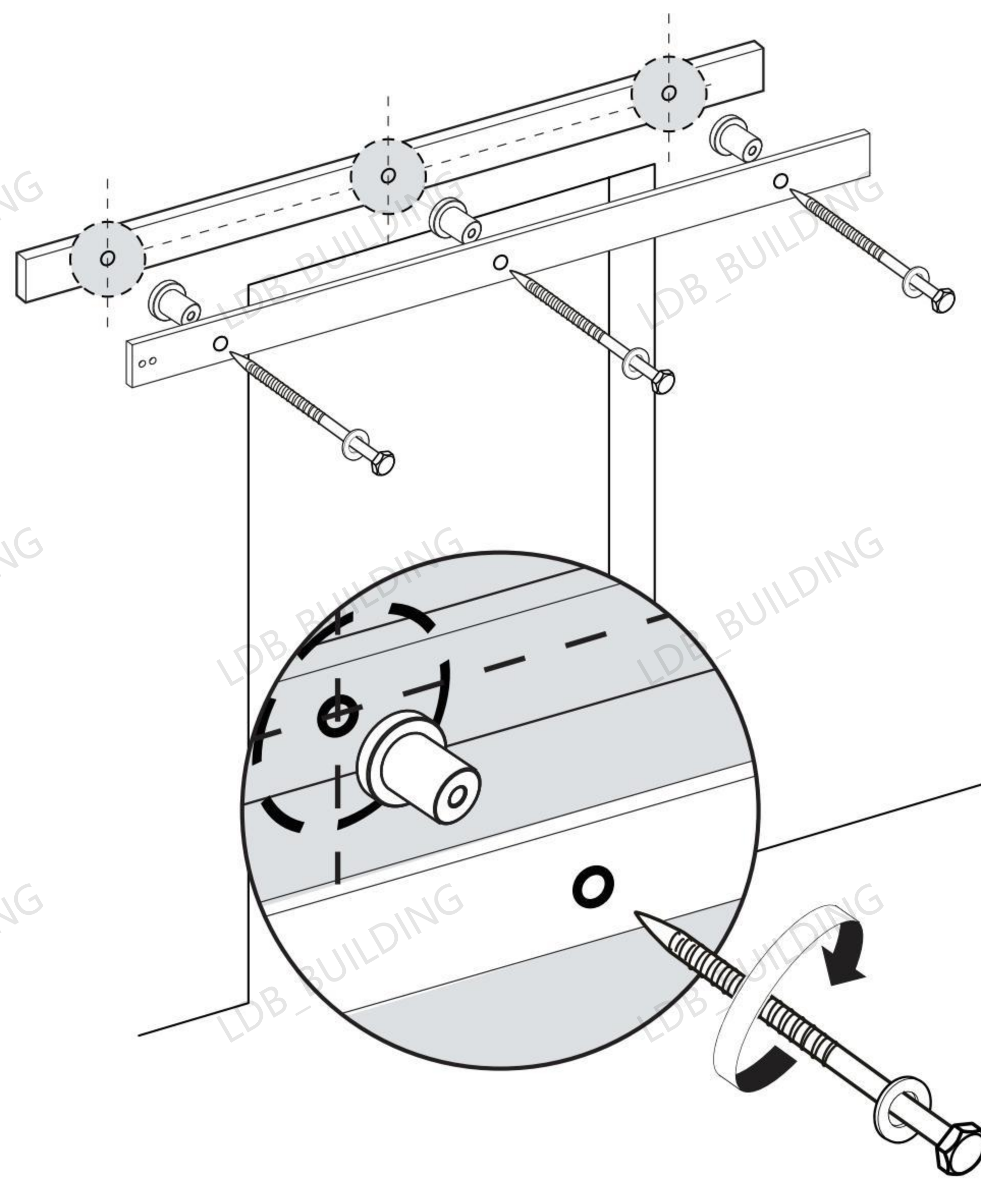

### B Drywall Installation.

Insert the lag bolt to wall spacer and holes directly.

## Product Assembly

### STEP-5

Installing BiFold butt hinges on the back for the door.

- Lay the doors to be joined together face down on a flat surface.
- Space the hinges 10" down from the top and up from the bottom of the door. Install a hinge in the middle of the door.
- Align the hinge knuckle parallel and directly over the joint between the two panels.
- Secure the hinges to the door with the supplied flathead screws.

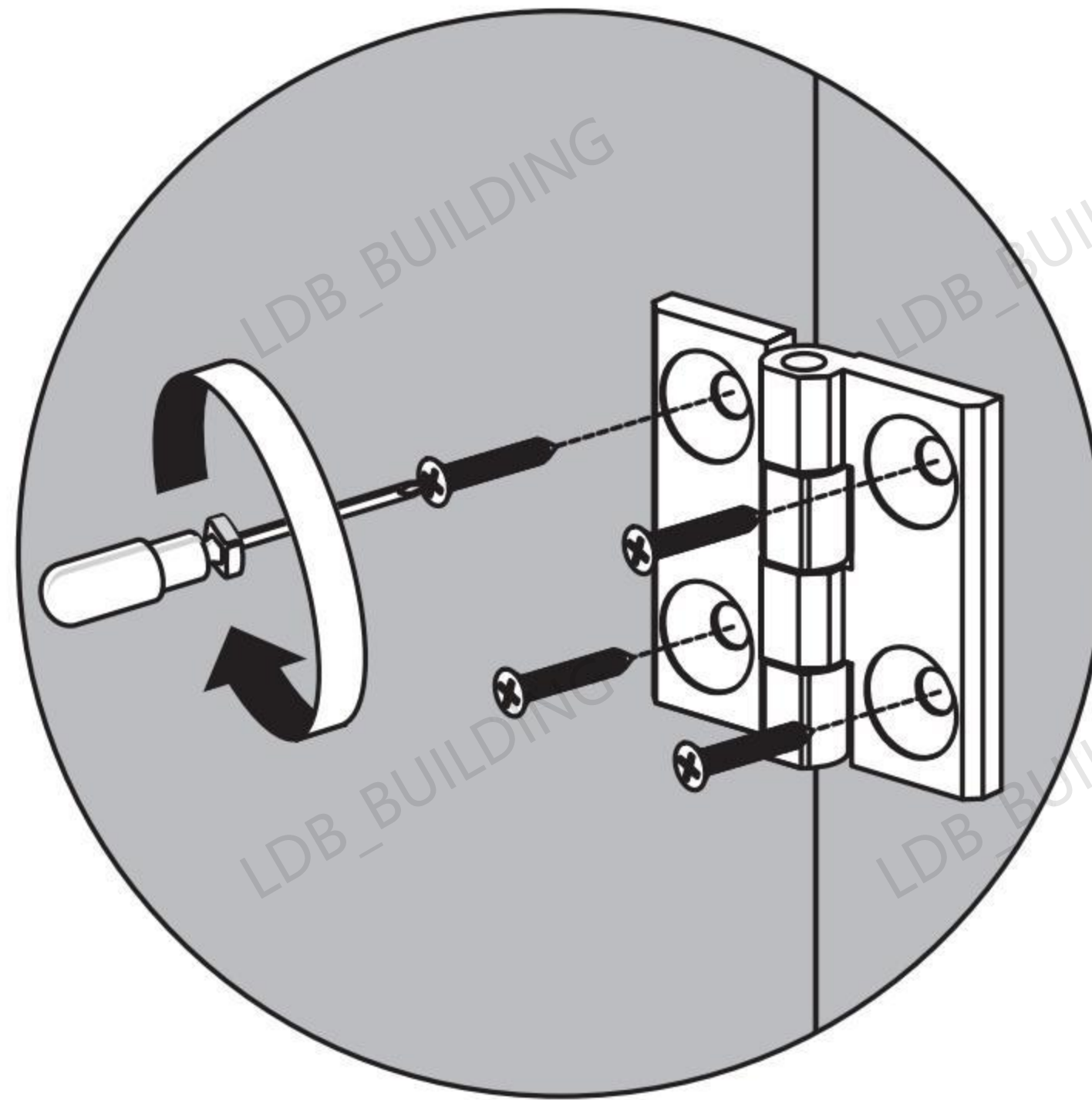

for bottom pivot is on the left  
bottom of the door.

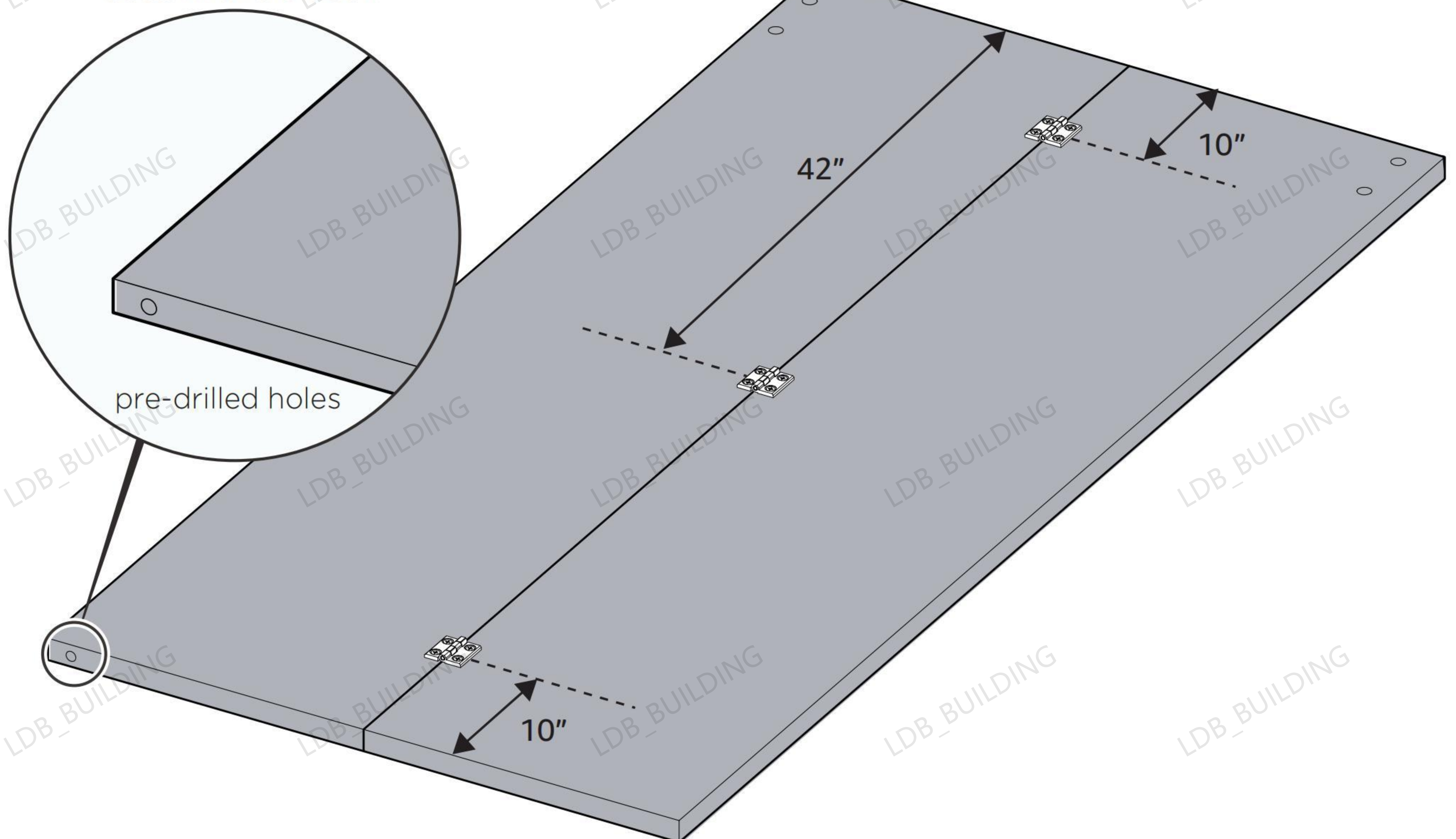

## Product Assembly

The picture below shows the appearance of the folding door and track after installation, with the hinge located on the back of the door

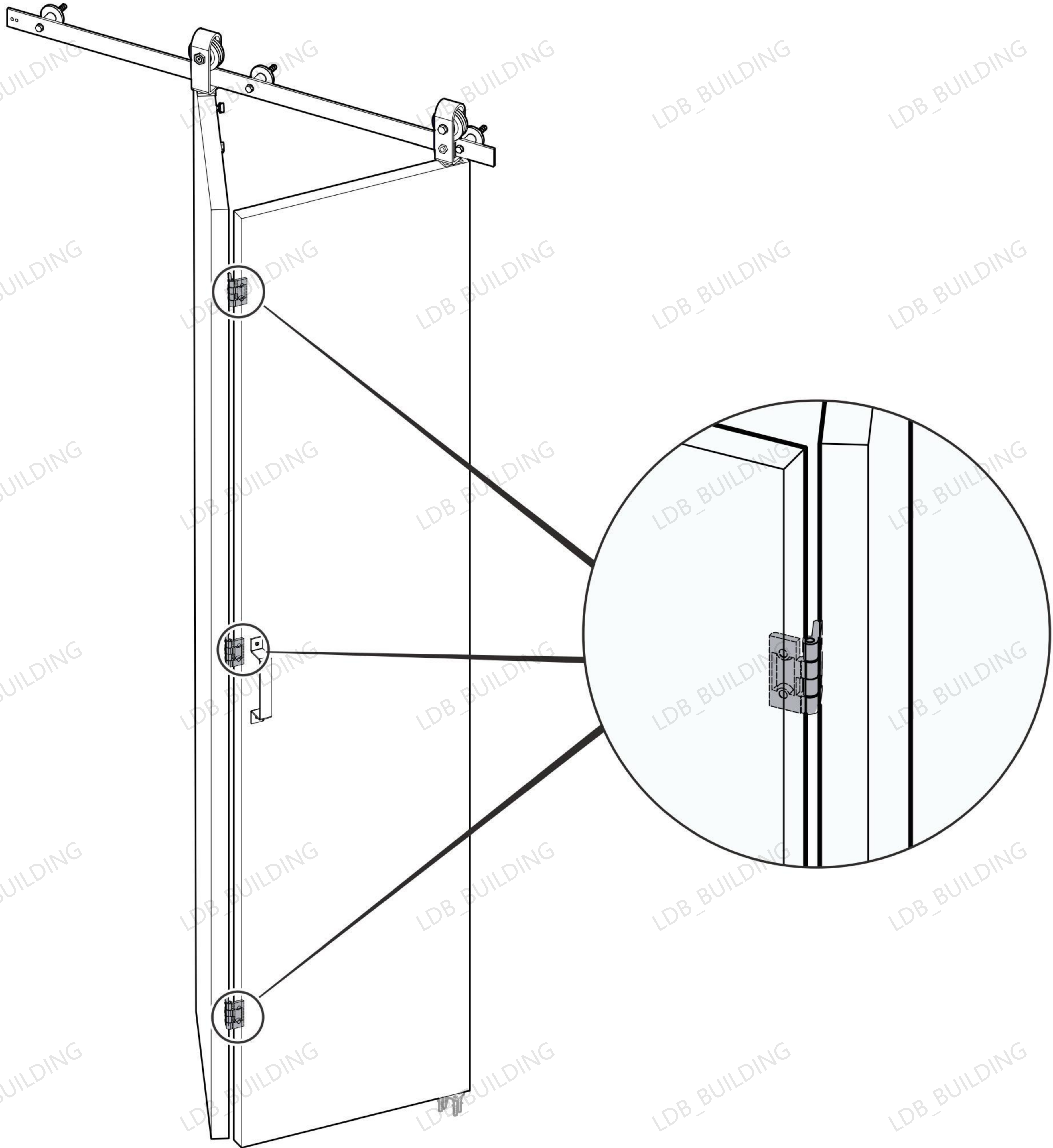

## Product Assembly

### STEP-6

First install the hex bolts (the holes for the hex bolts is pre-drilled.) then put in the supplied screws of the top of the door .

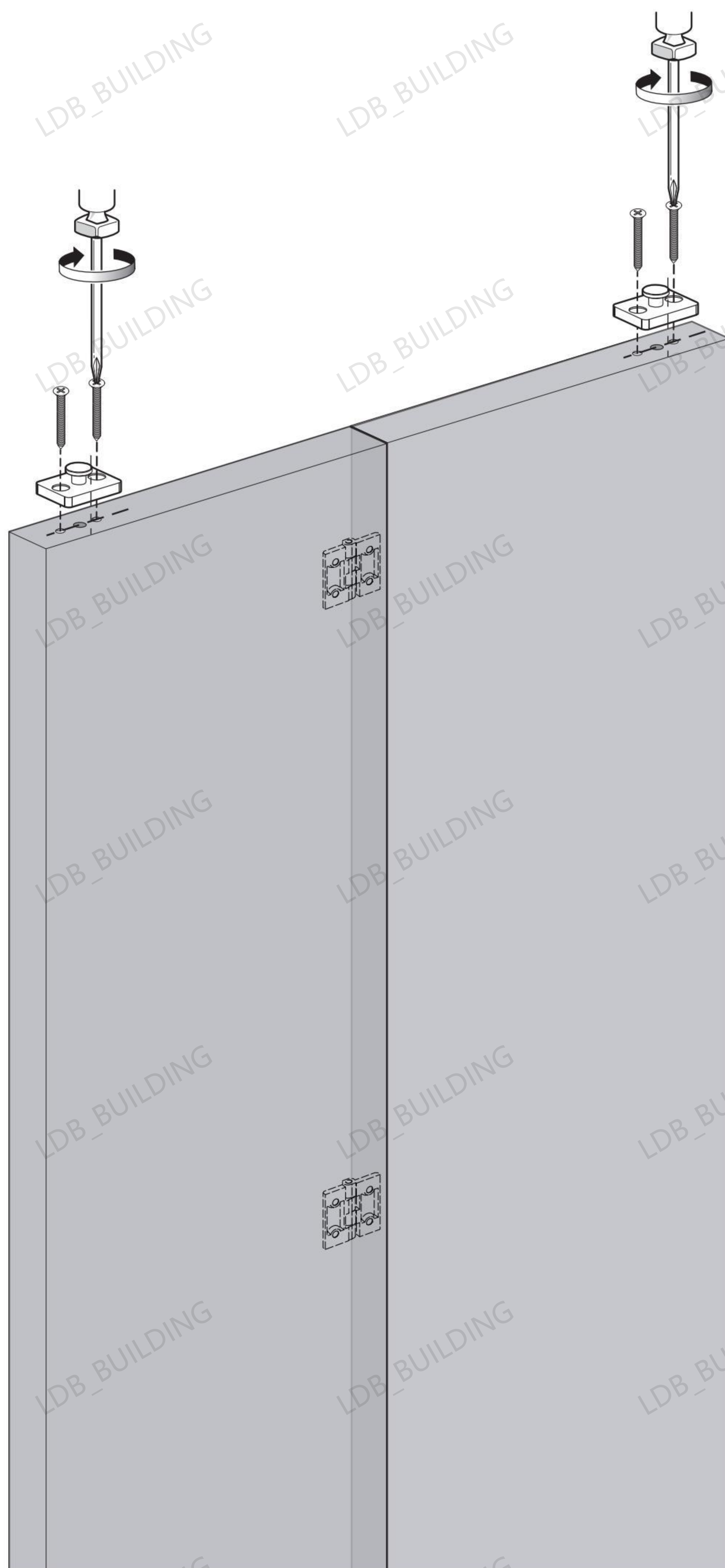

## Product Assembly

### STEP-7

Hang the fixed roller and the adjustable roller in the correct positions on the rail

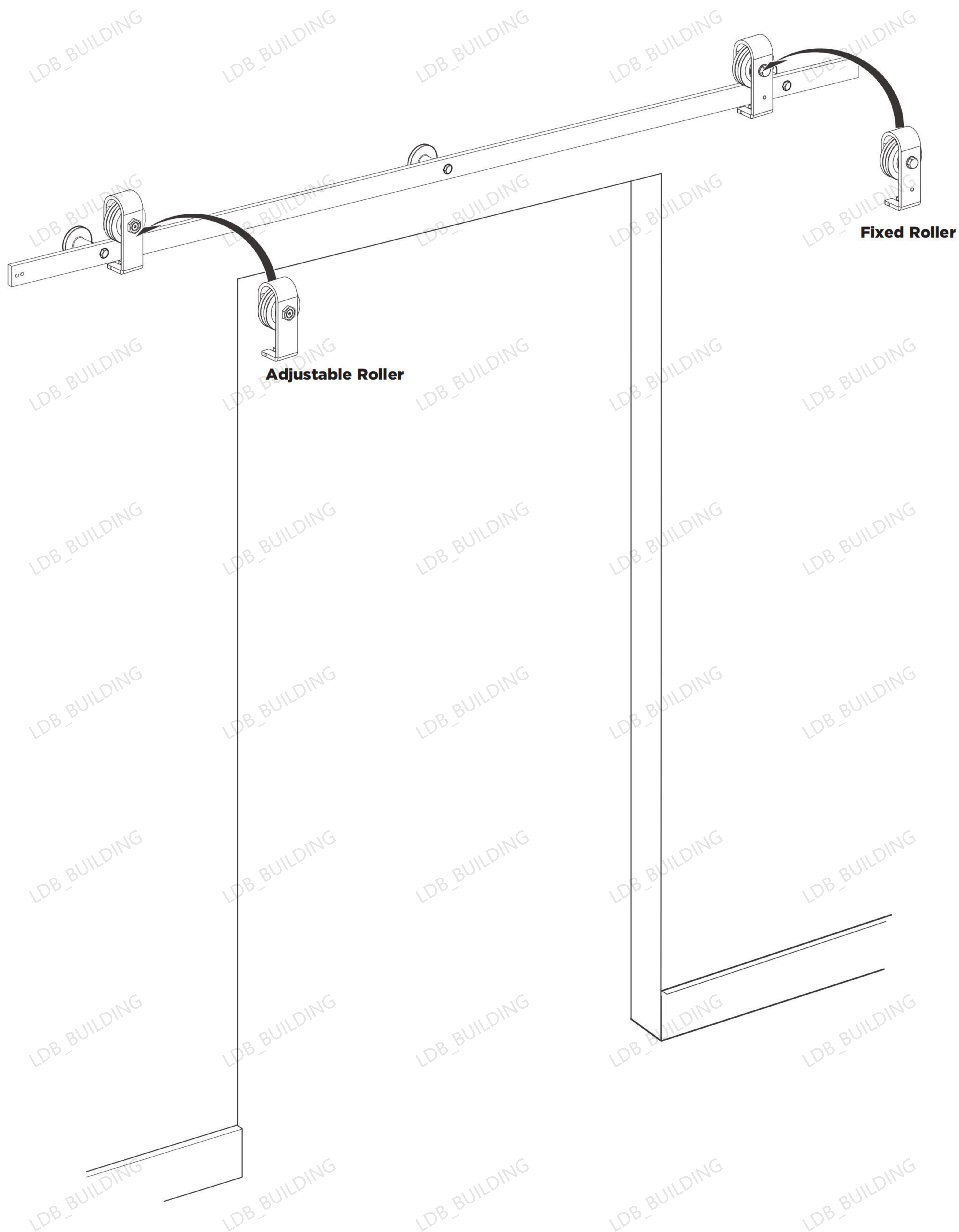

# Product Assembly

## STEP-8

- A** Determine pivot of the position of the Bottom Pivot Plate according to the marked axle centre line in the Step-1

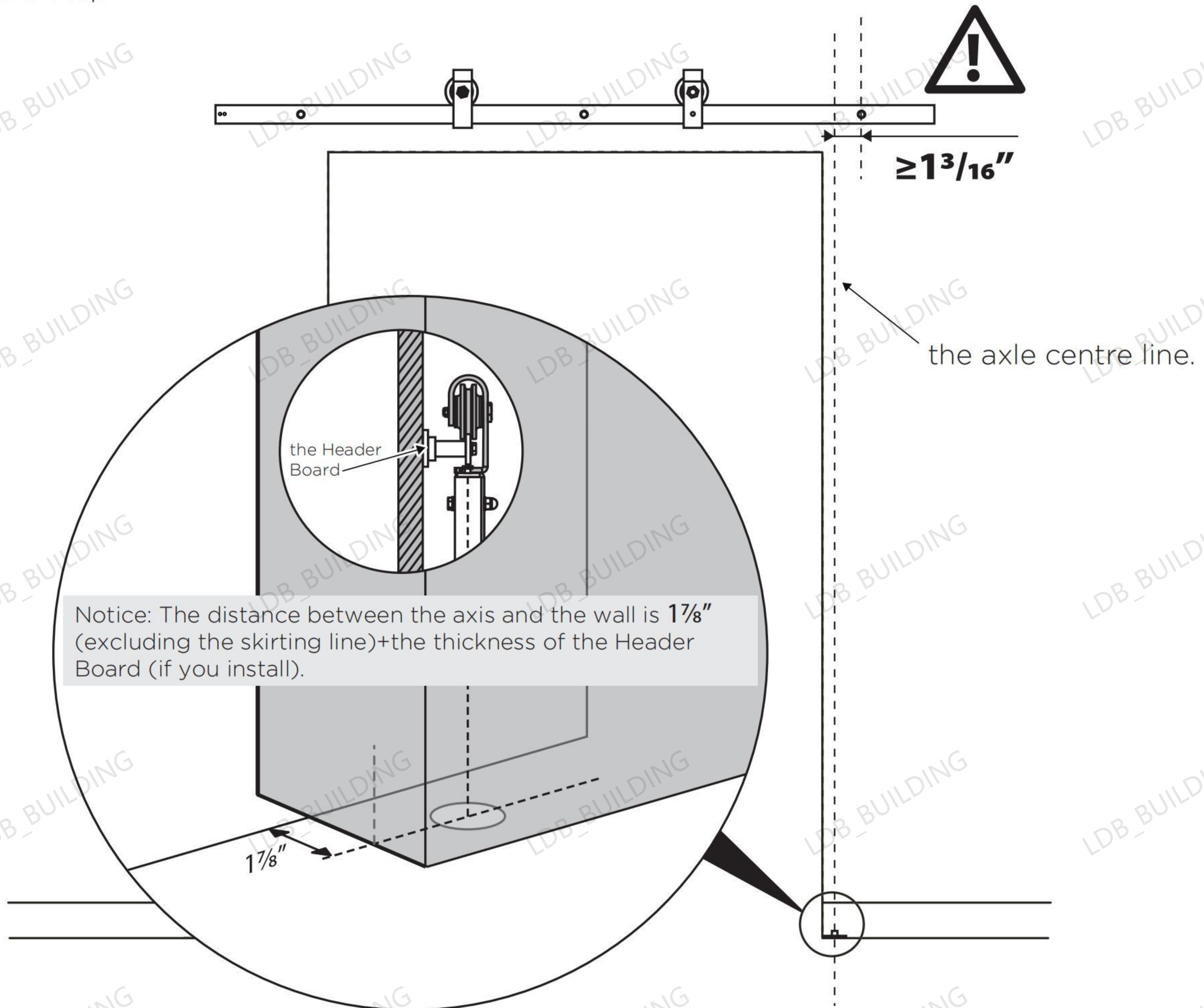

- B** Install the Bottom Pivot Plate according to the pictures below.

- C** Use a mallet to knock the brass sleeve into the Pre-primed hole at the bottom of the door.

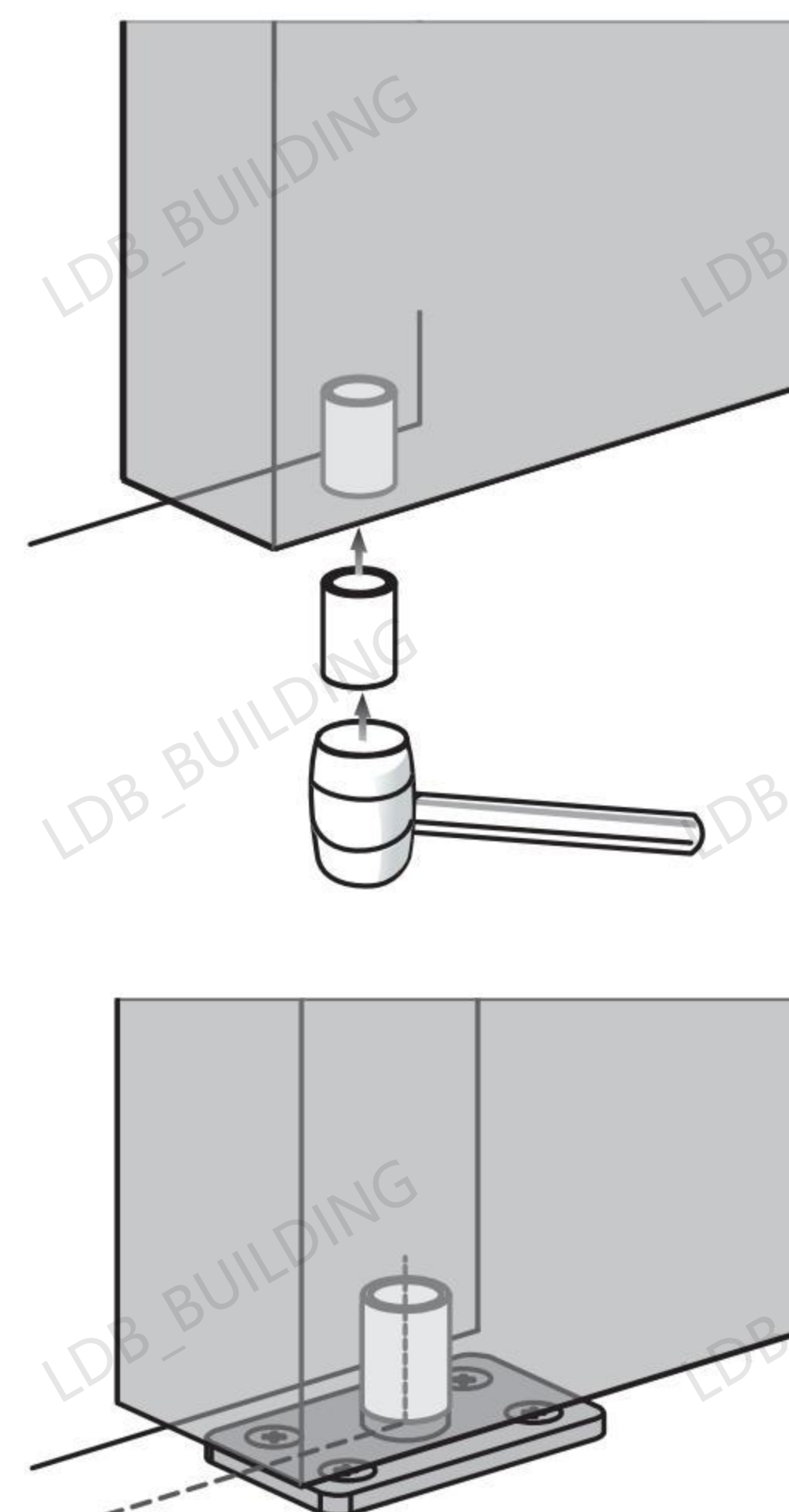
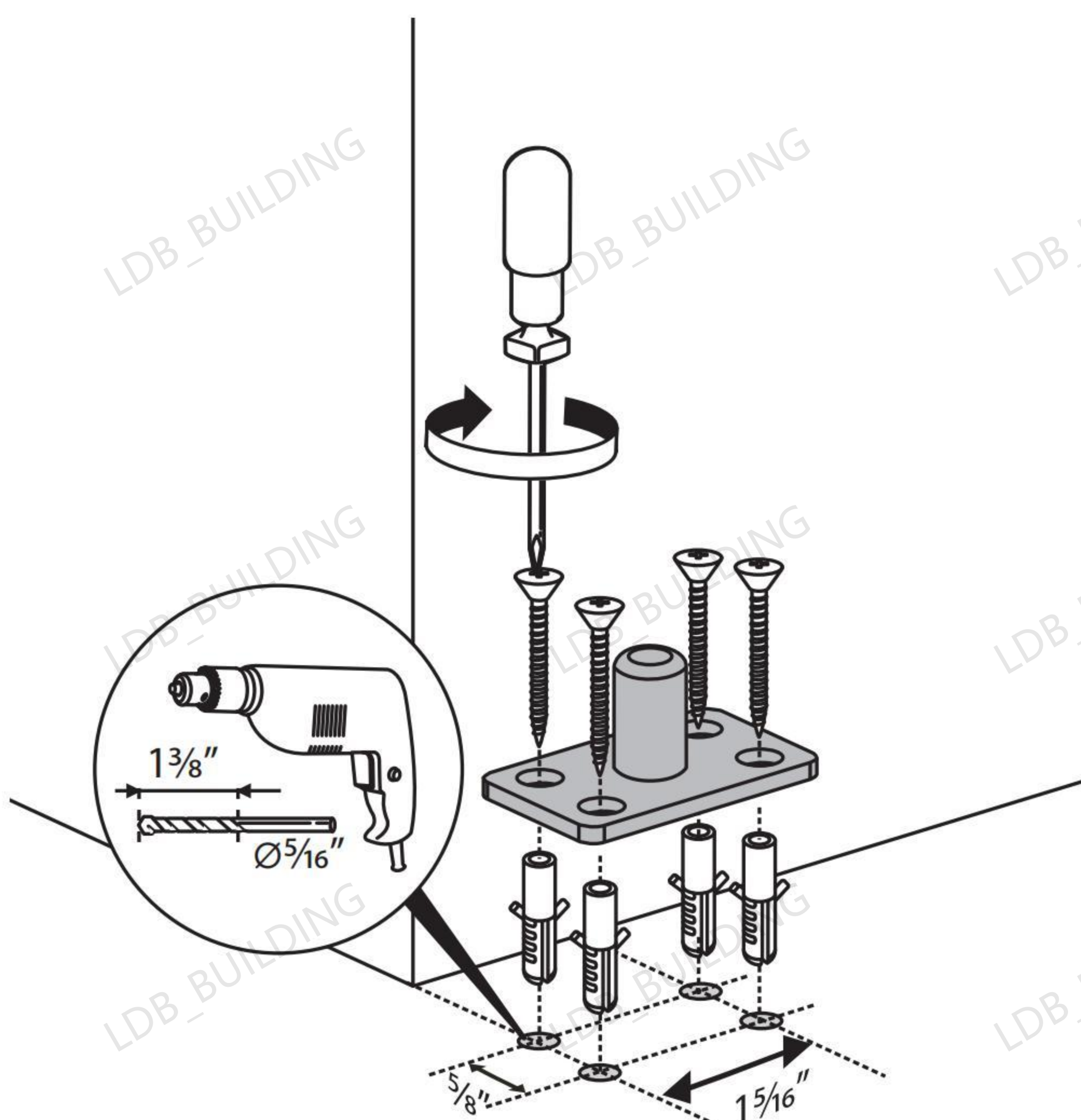

## Product Assembly

### STEP-8(for double door)

- A** Determine pivot of the position of the Bottom Pivot Plate according to the marked axle centre line in the Step-2

**Note:** the distances between 2 axle centre line are  $2L-2\frac{3}{4}"$  (L=length of single door)

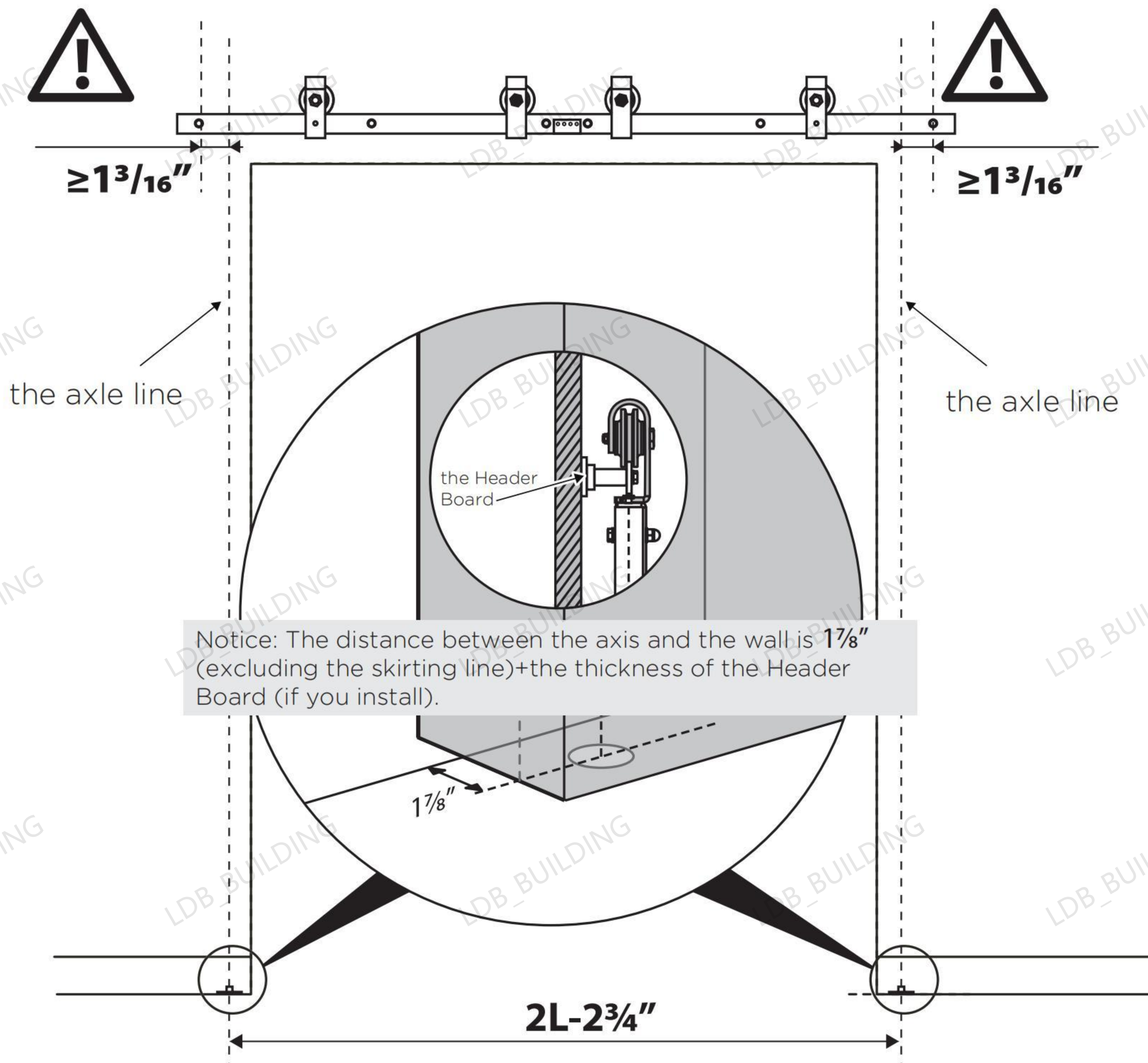

- B** Install the Bottom Pivot Plate. (same as single door)

- C** Use a mallet to knock the brass sleeve into the Pre-prilledhole at the bottom of the door. (same as single door)

# Product Assembly

## STEP-9

Using the set screws to lock the fixed roller assemblies to the top connector plates.

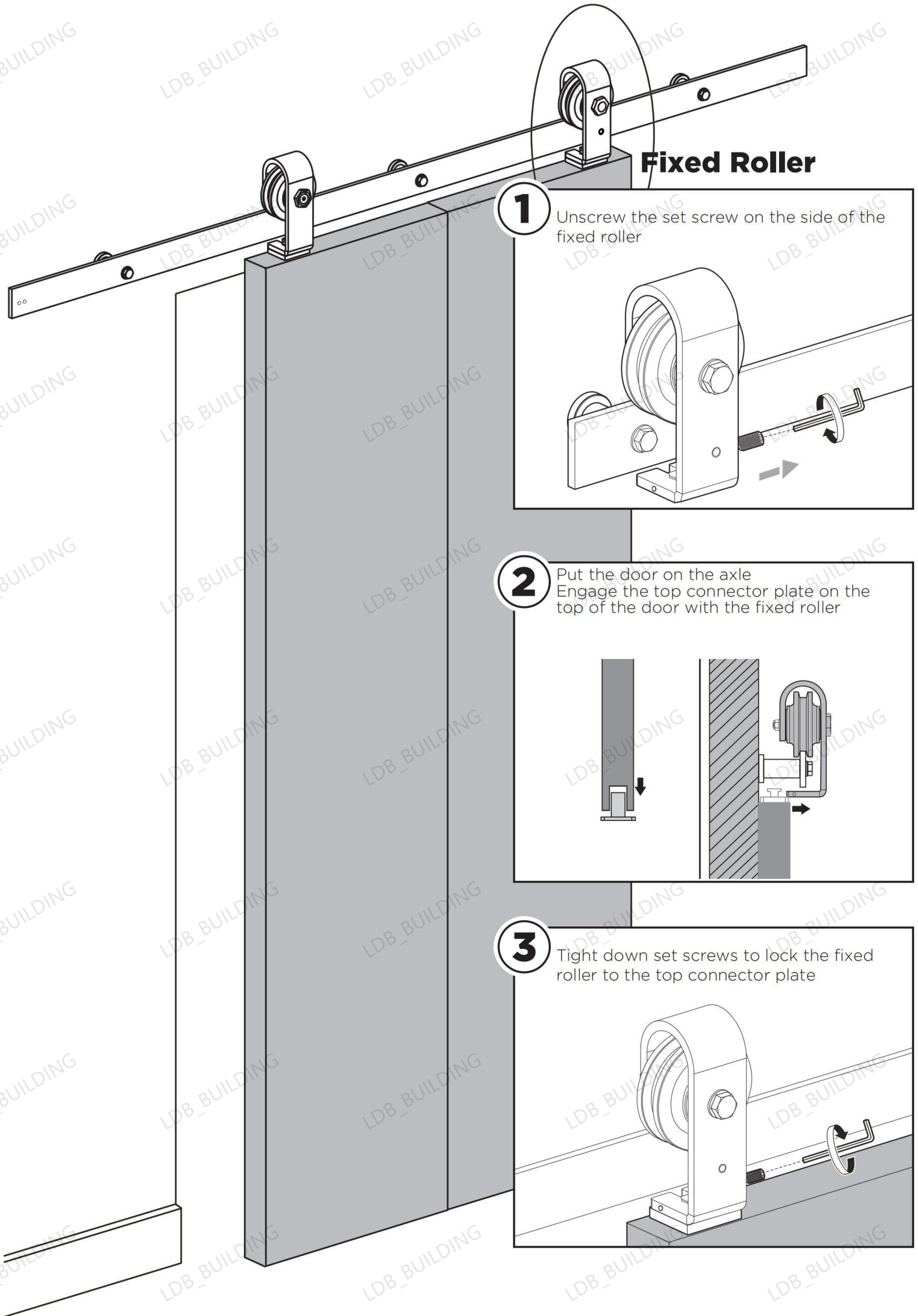

# Product Assembly

## STEP-10

Use the set screws to lock the adjustable roller assemblies to the top connector plate.

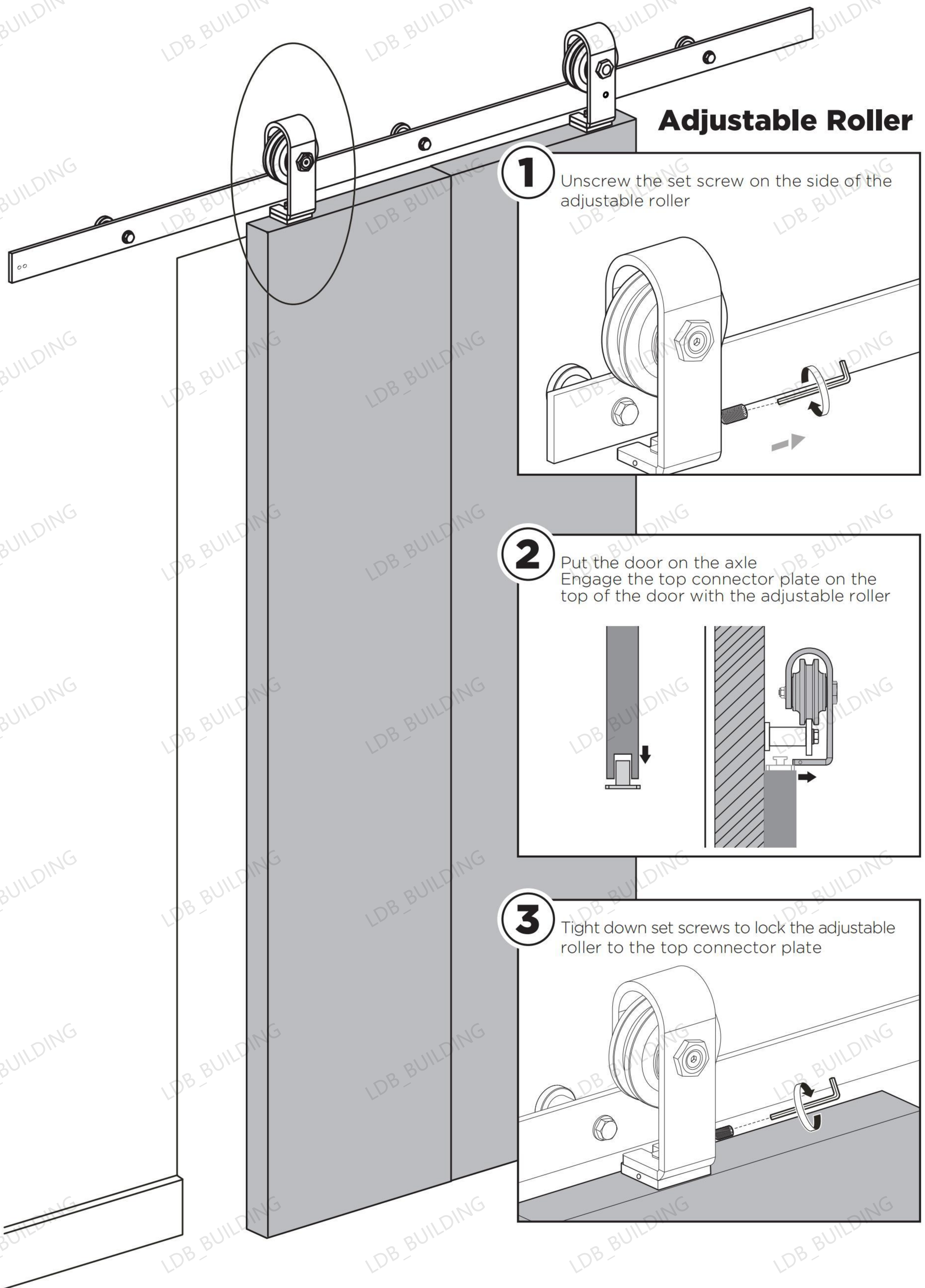

# Product Assembly

## STEP-11

Adjust the height of the adjustable roller to to a suitable position , ensuring the doors are level.

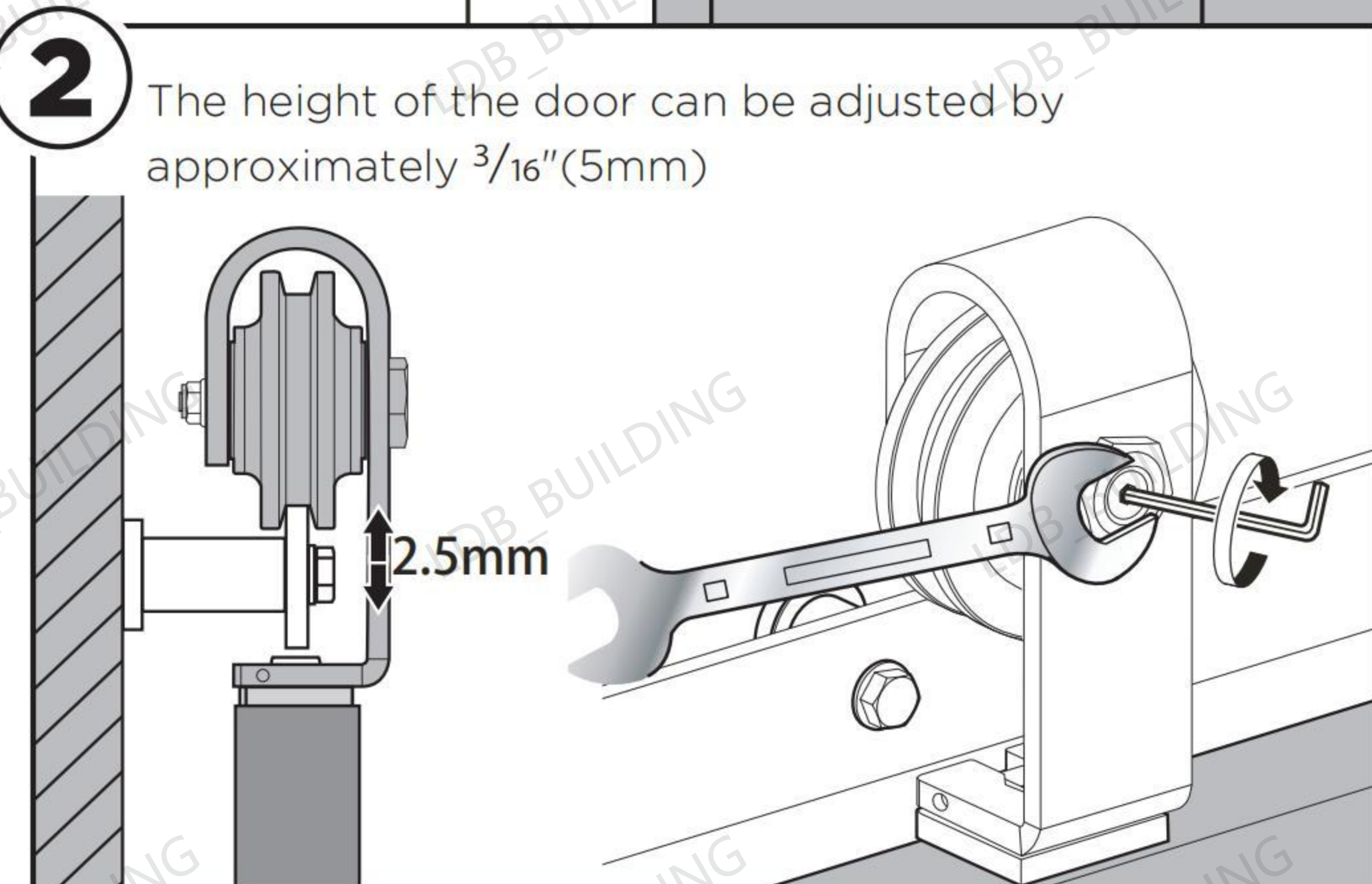
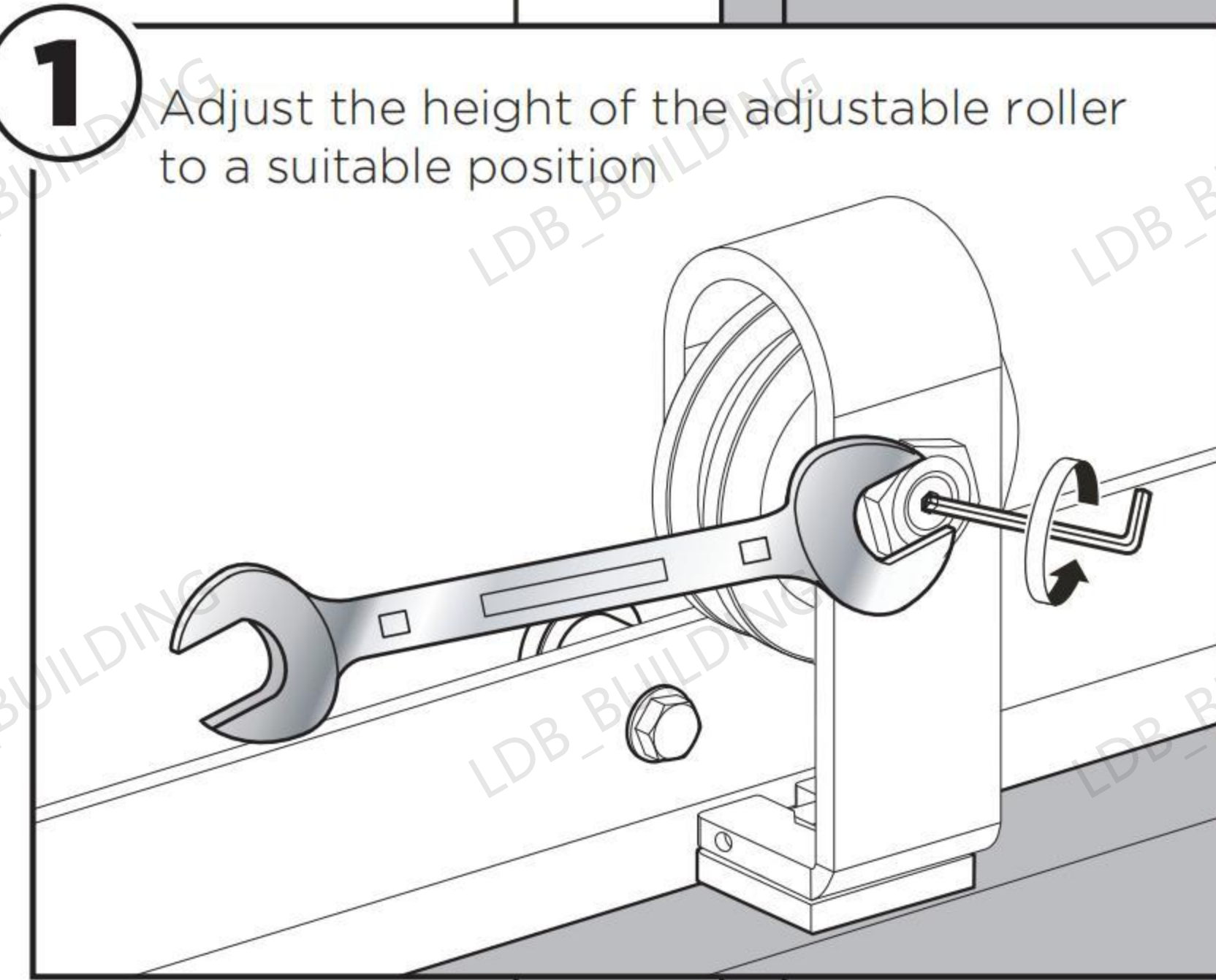
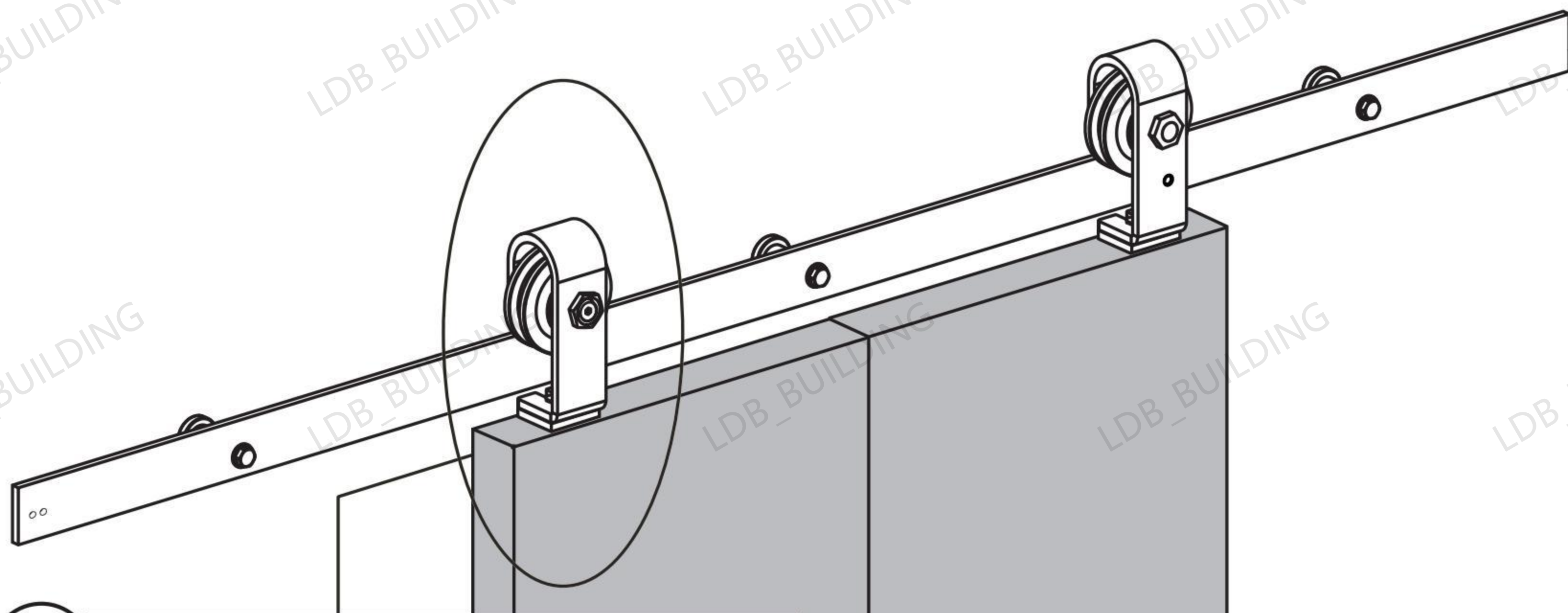

# Product Assembly

## STEP-12

Lock the fixed roller onto the rail by tightening the long set screw. Use the supplied wrench to tight the hex-head nut onto this set screw

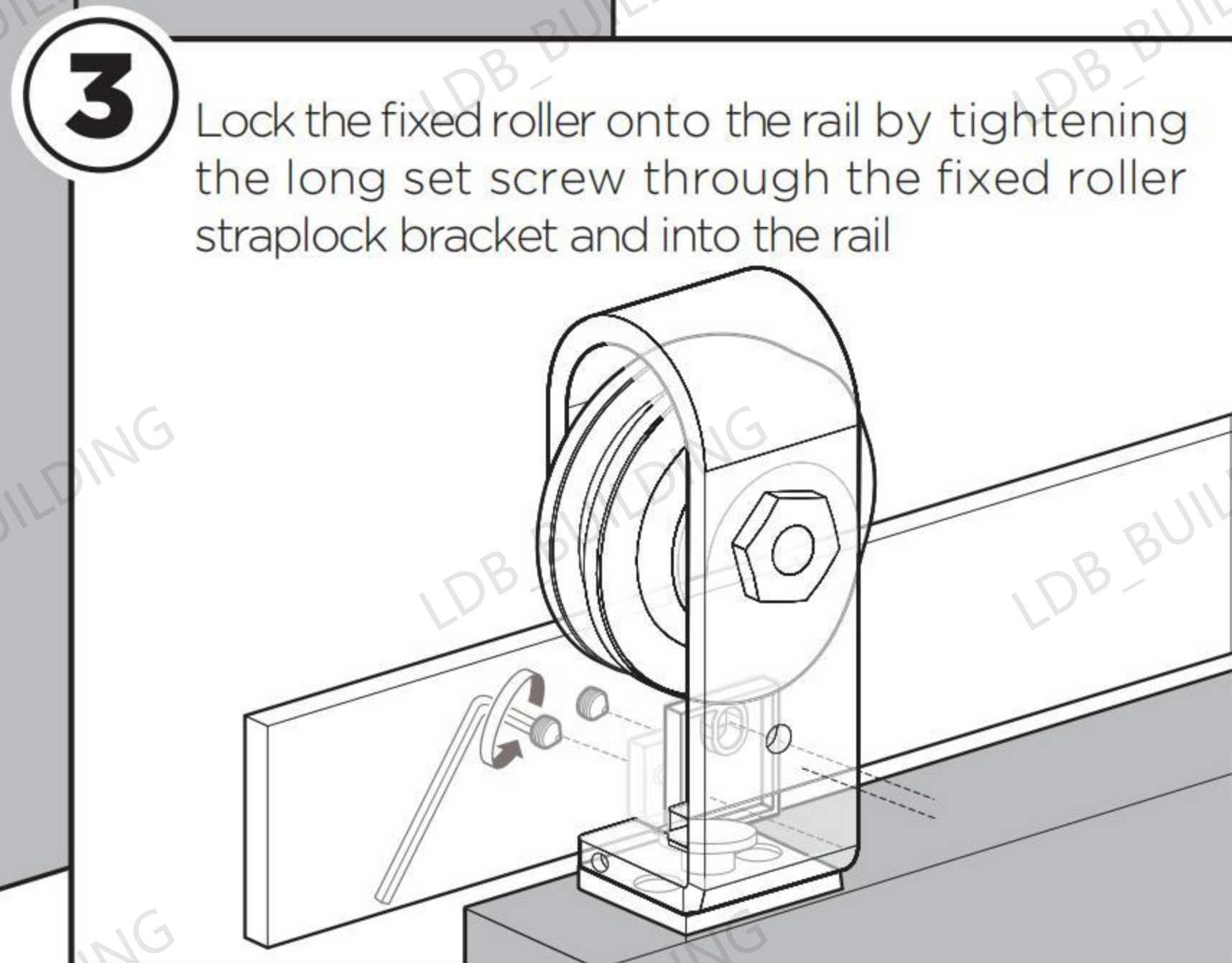
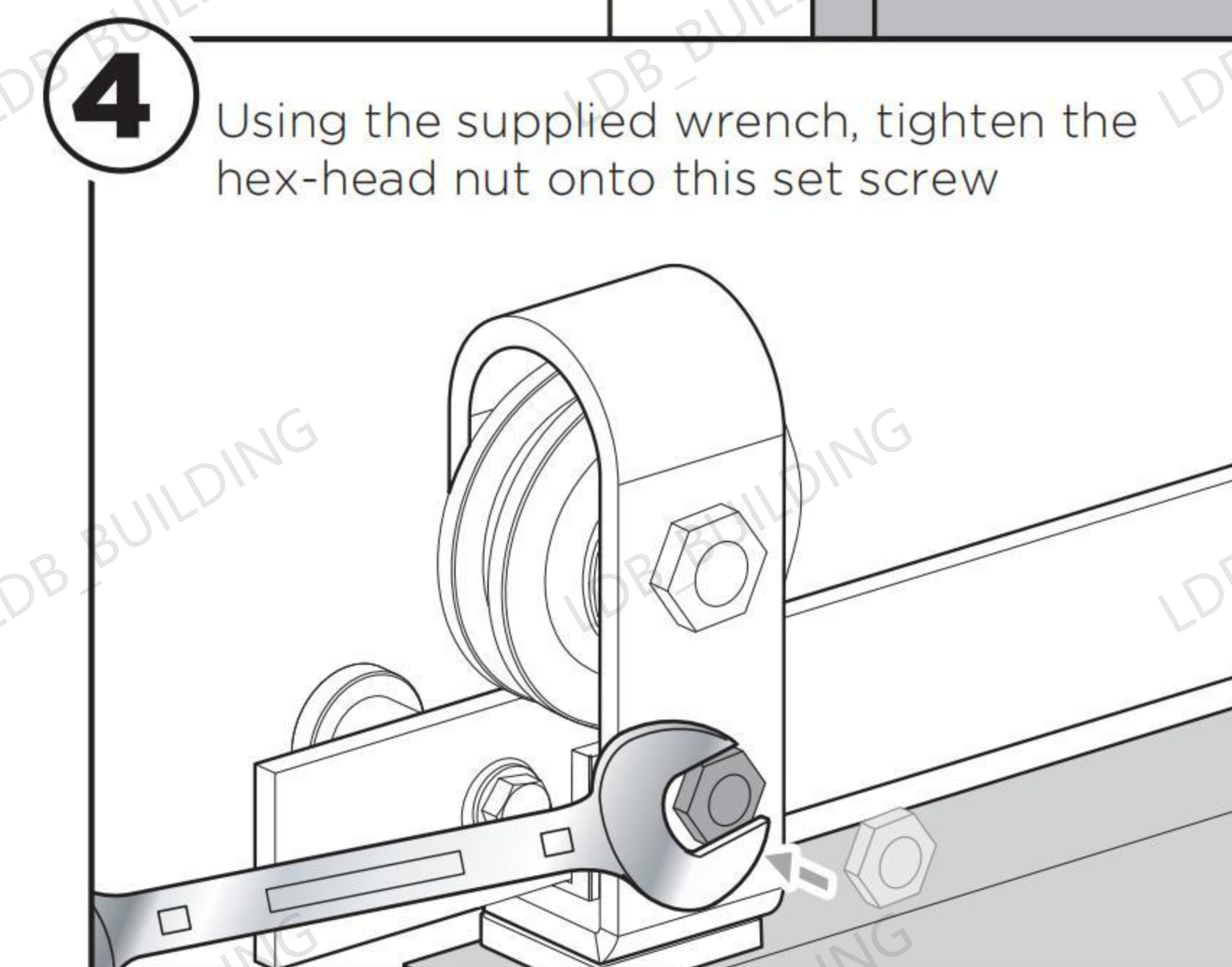
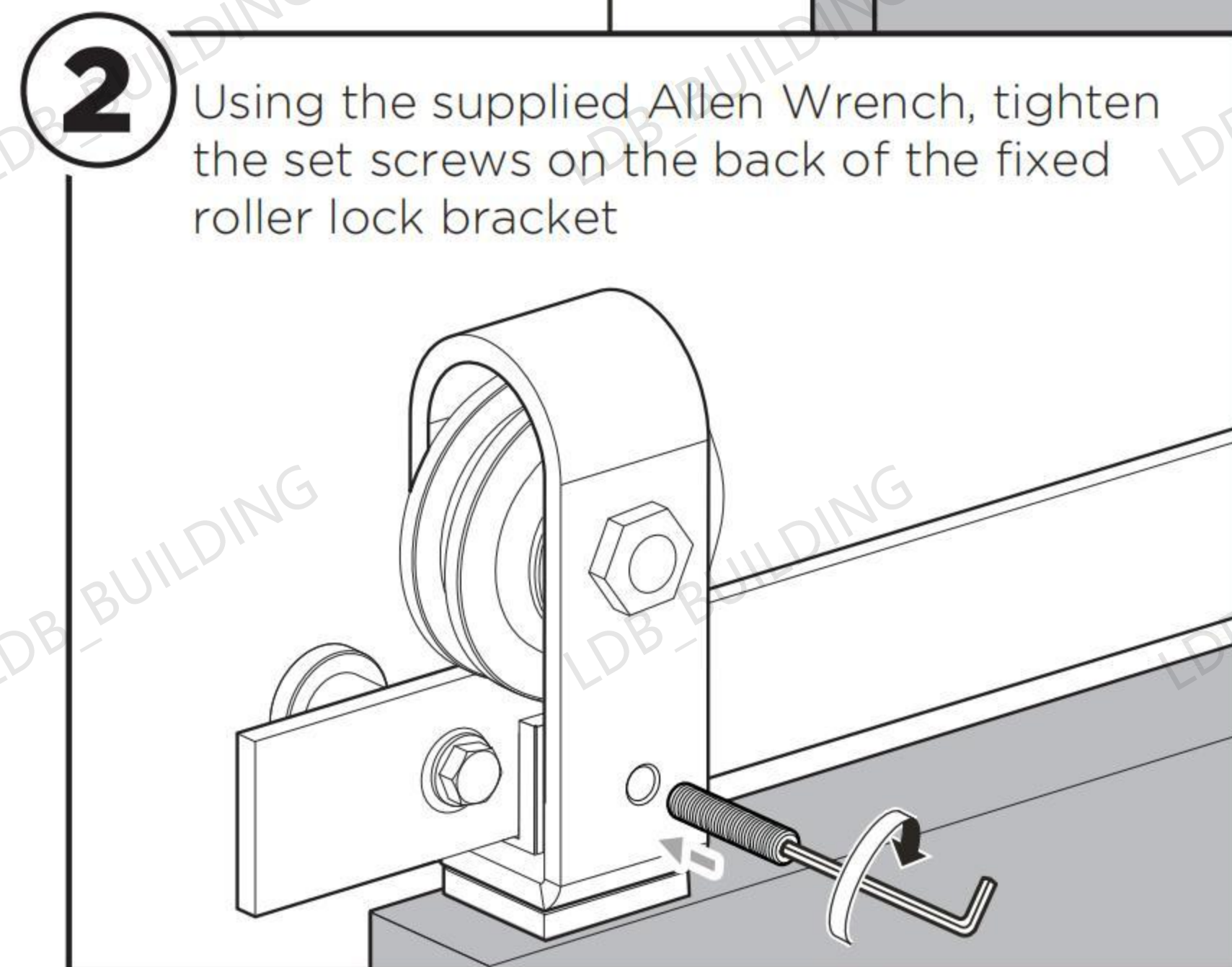
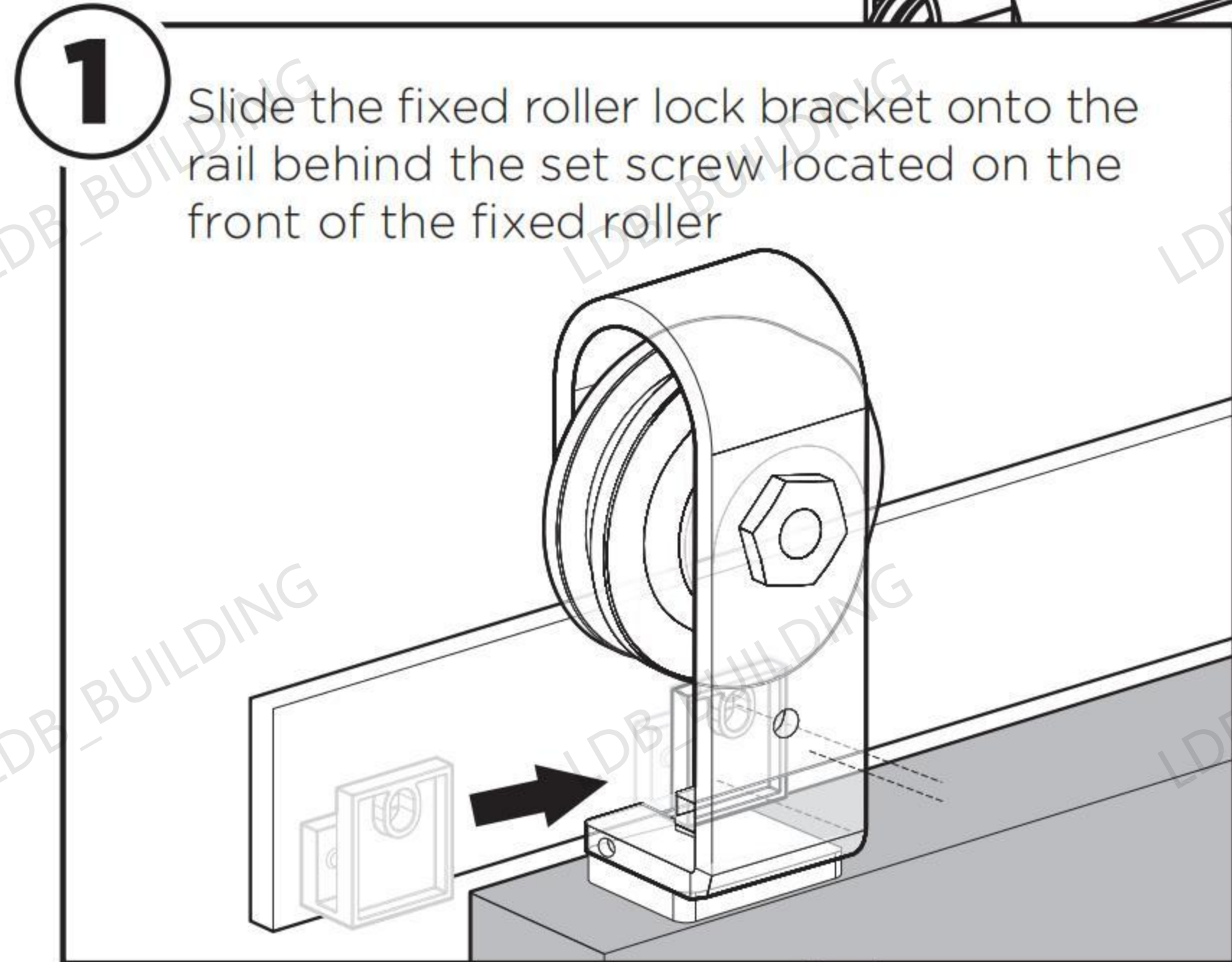

# Product Assembly

## STEP-13

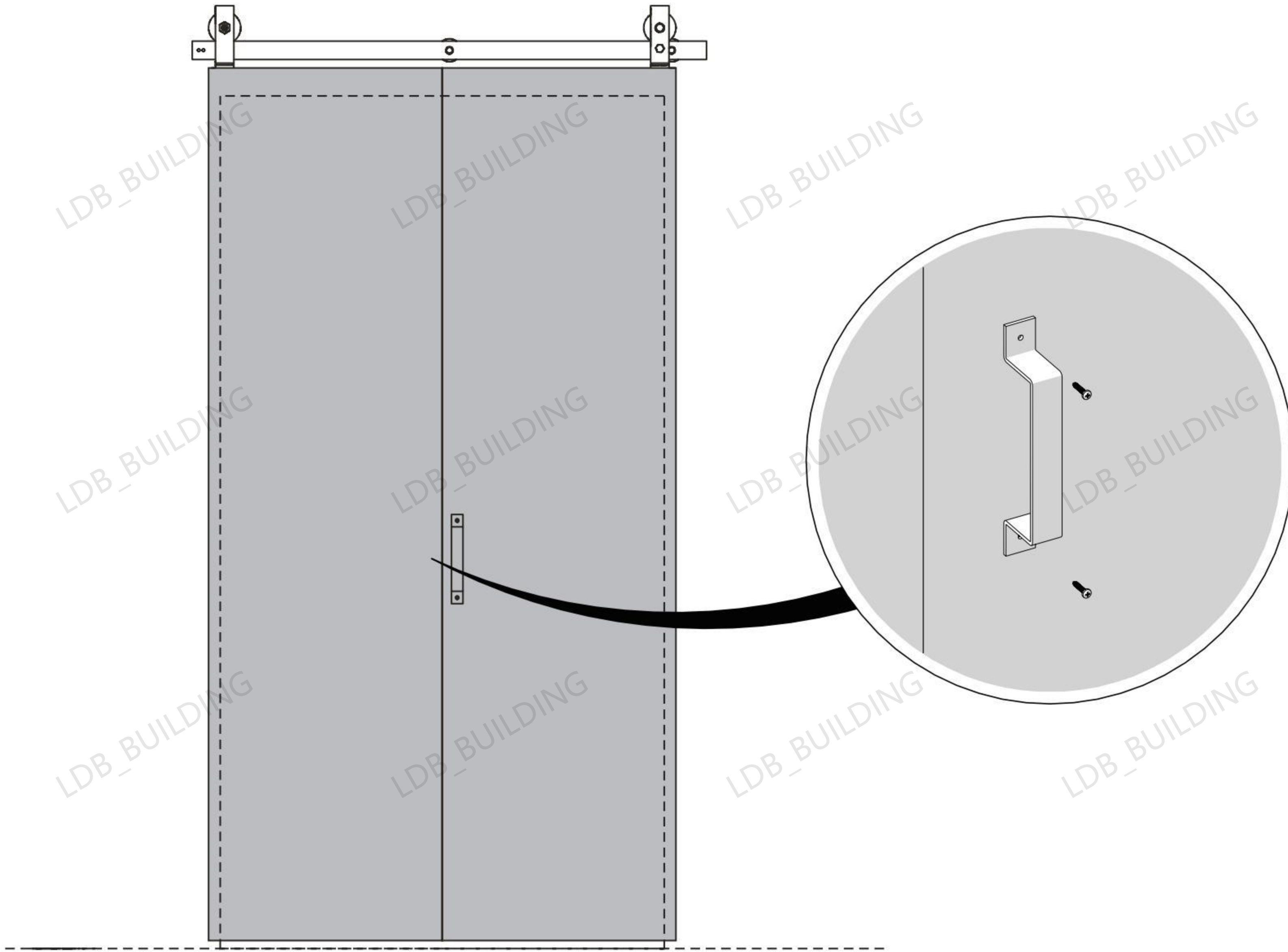

## STEP-14

For double doors installation, proceed with the step 14. If installing a single door, skip this step. Stick the anti-collision strip on the door. In order to prevent the gap between the door and the door from being too large, please stick it diagonally as shown below.

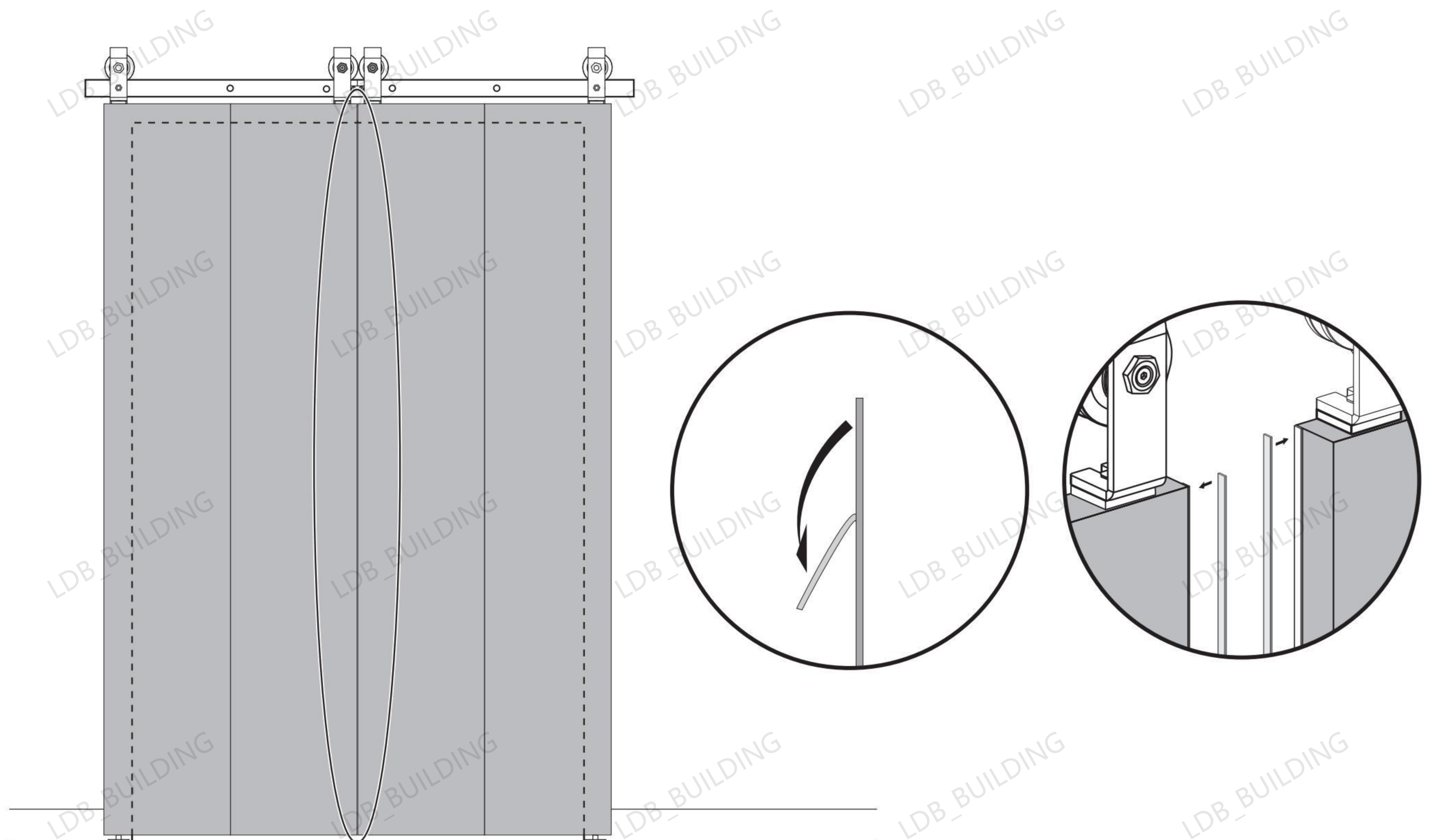

Question about your product? We're here to help. Visit us at:

**Email: [help@bestbarndoor.com](mailto:help@bestbarndoor.com)**

## **WARNING**

Read instruction fully before starting the installation. Not following the installation instructions may cause the unit to work in unsafe manner and cause injury.

The barn door kit has been designed to work as a total system. Any modification to the door or the hardware will void the warranty and may cause the unit to work improperly.

Always wear appropriate personal protection equipment when using tools and follow manufacturer's operating instructions.

The weight of the barn door requires 2 people during installation.



## **CAUTION**

Mishandling of heavy objects (i.e., doors) may cause a loss of balance and serious injury. Always be sure you have a secure hold on the object and are balanced before moving the object. Always wear safety shoes when lifting heavy objects.

Getting body parts (i.e., hair, fingers) caught in moving parts may cause pinching and serious injury. Do not put fingers in parts that may move and always remove or contain anything on your body that may become entangled with a moving part.

Closing sliding doors with your hand on the end of the door may result in your hand, or fingers, getting caught between the door and other solid objects (i.e., another door, molding) causing serious injury. Always use the door handle to close doors.

## **Usage Statement**

Use of excessive force when opening and closing the door(s) may result in damage to the hardware. Always hold the handle to gently move the door(s).