

User's Manual

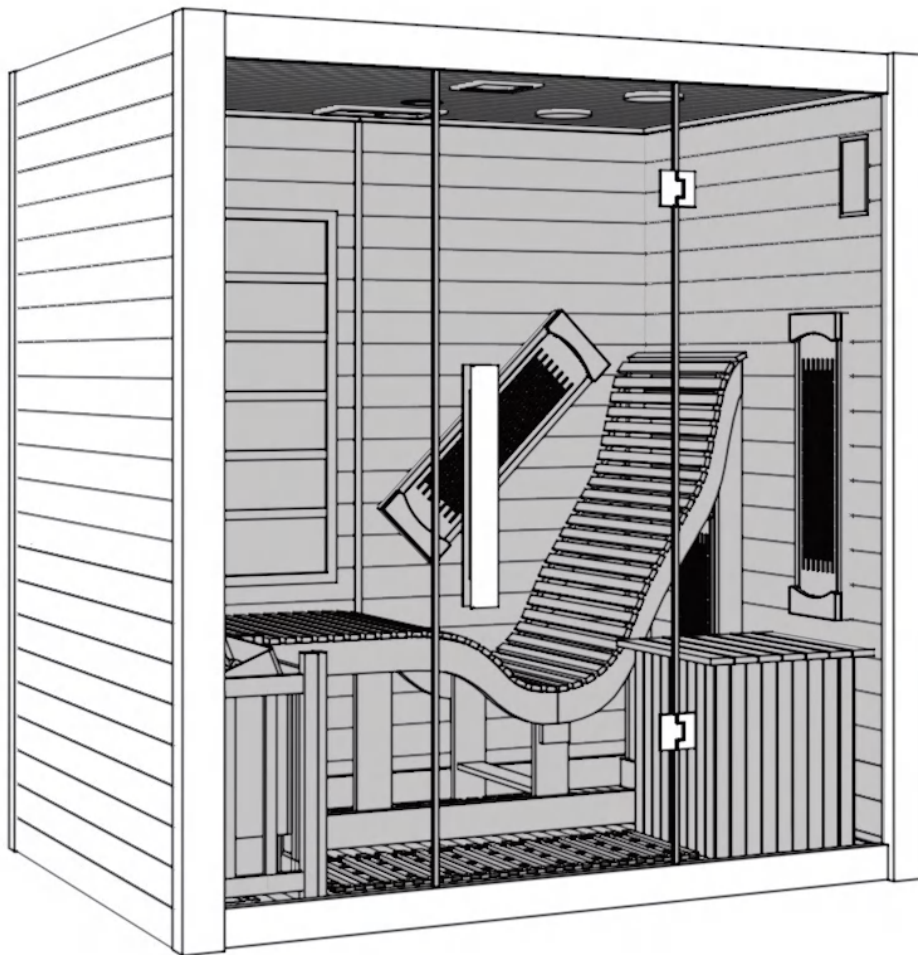

Contents

Sequences and contents of sauna assembly	Page
Electrical Requirements	- 3 -
Tools you need to prepare	- 3 -
Components of sauna	- 4 -
Installation Instructions	
1. Base assembly step	- 5 -
2. Back wall assembly step	- 5 -
3. Side wall assembly step	- 6 -
4. Top wall assembly step	- 8 -
5. Internal accessories assembly step	- 9 -
(1) Install the Recliner	- 9 -
(2) Install the table	-10-
(3) Install the stove and frame	-11-
(4) Install the oxygen Ionizer	-12-
6. Front wall assembly step	-13-
Accessories	-15-
Control Panel Operation Instructions	-16-
Usage Guide	-19-
Saunas and Contraindications	-20-
Troubleshooting	-22-
Our story	-23-
Warranty Policy	-24-

Electrical Requirements

Each sauna will require a dedicated circuit when plugged in an outlet according to the chart below. A dedicated circuit requires that no other appliance should share the outlet/circuit with the sauna. Failure to comply with this requirement may cause electrical interruption and diminished performance. It is recommended that a qualified electrician install your dedicated electrical wiring for proper sauna functionality and to avoid any potential electrical hazards. Please make sure the sauna is properly grounded. Serious injury may result if proper electrical requirements are not met.

Please follow all instructions carefully. Keep the sauna away from any potential hazards including any water source or liquids. Select a dry suitable location for the sauna installation. Do not expose the heater elements to any water source or liquids as it may cause electrical shock. Should you have any questions, please do not hesitate to contact the supplier.

Please read the following directions carefully. The sauna installation requires a minimum of 2 people. You should not try to install the sauna on your own as damage will easily occur.

Tools you need to prepare

Power Drill x 1	Adjustable Wrench x 2	Herringbone ladder X1
		

Components of sauna

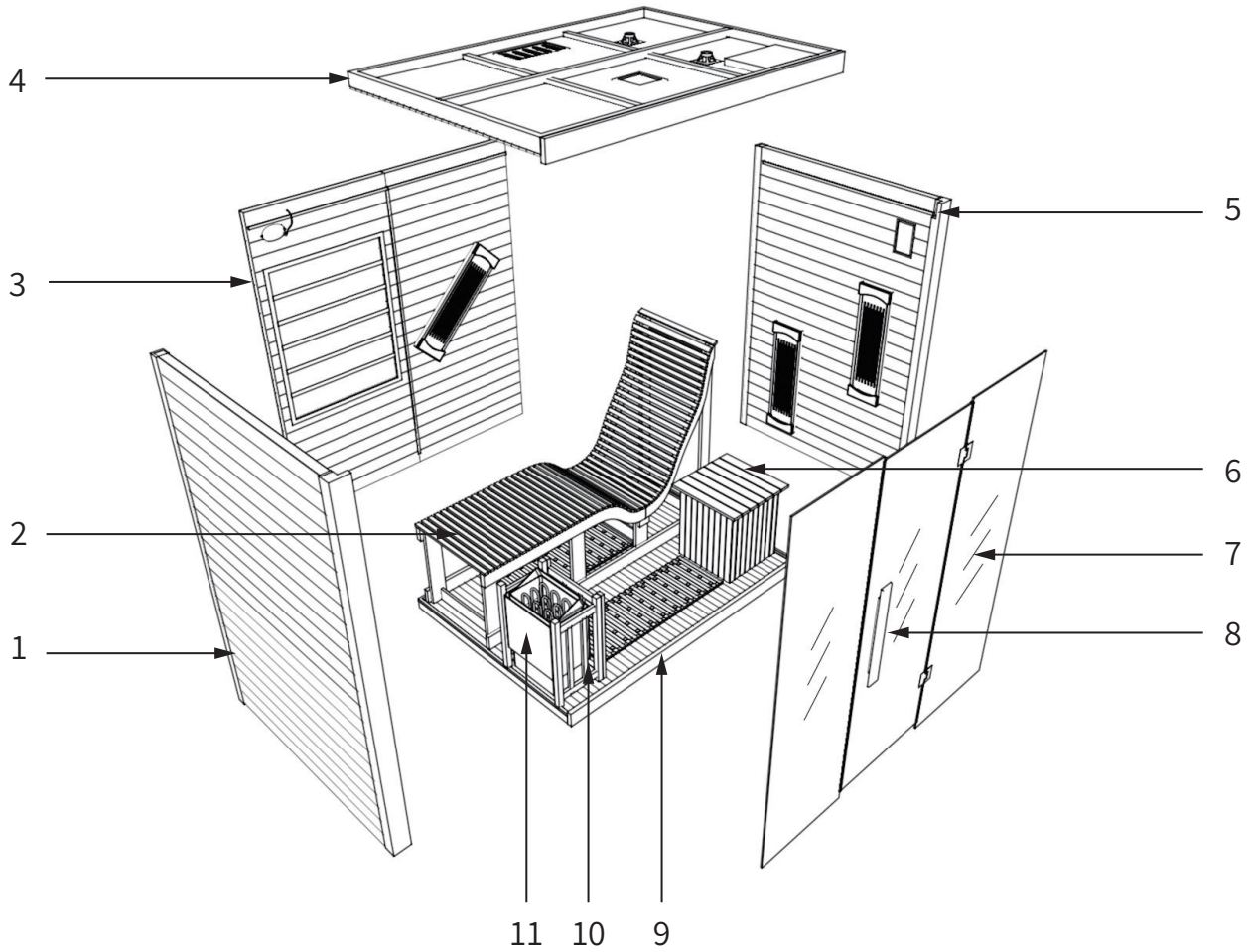

NO.	Part Name	Quantity	NO.	Part Name	Quantity
1	Left side pane	1	7	Front glass	3
2	Recliner	1	8	Wooden door handle	1
3	Back panel	2	9	Bottom panel	1
4	Top panel	1	10	Stove frame	1
5	Right side panel	1	11	Sauna stove	1
6	Table	1	/	/	/

Installation Instructions

1. Base assembly step:

① Place the base face up on the ground.

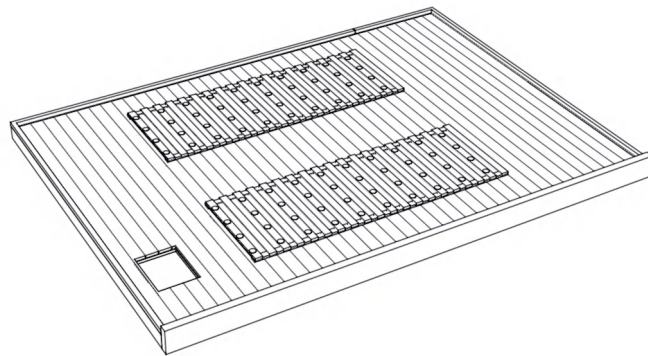

2. Back wall assembly step:

Steps to use the buckle.

Inner Locking Sytem:

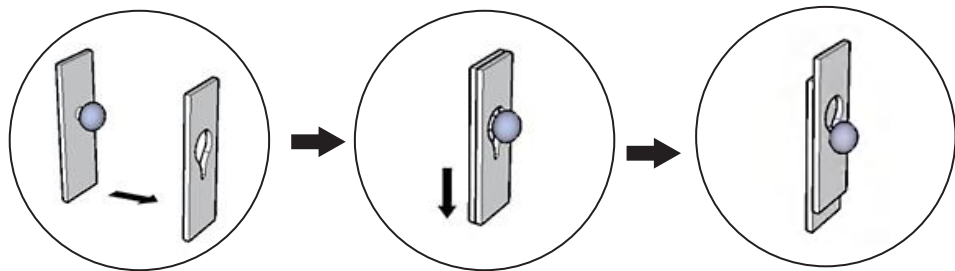

① Place one of the back wall.

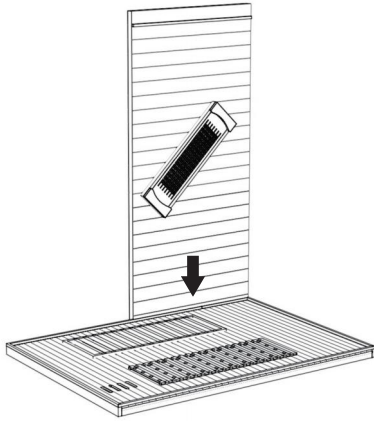

② Fix the two back panels with buckles.

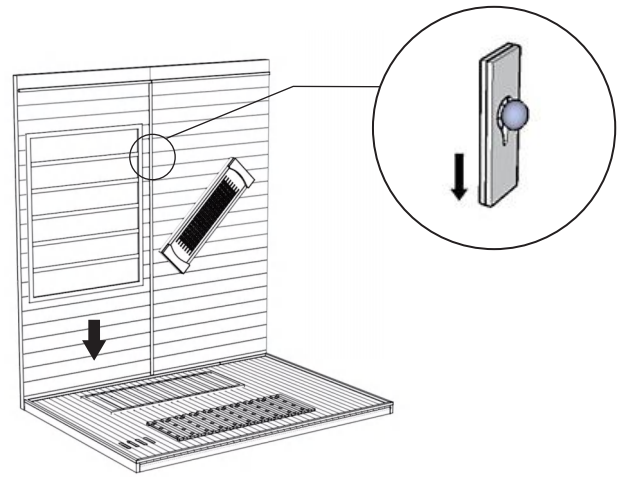

3. Side wall assembly step:

① Connect the side wall to the back wall.

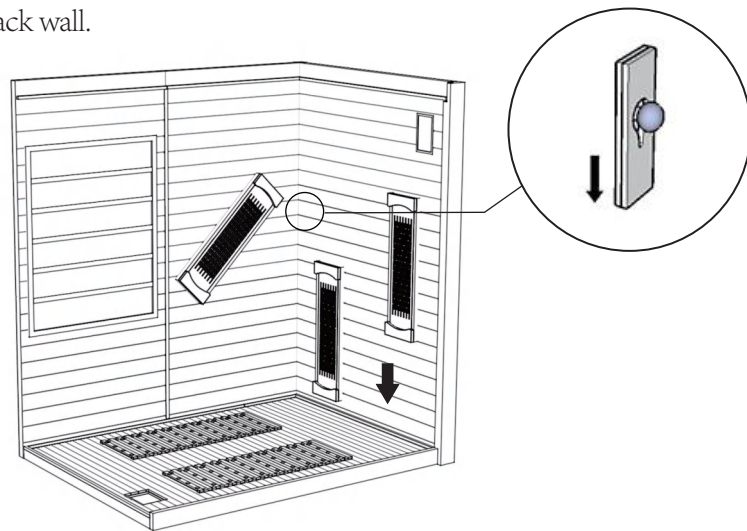

② Install the other side panel using the above steps.

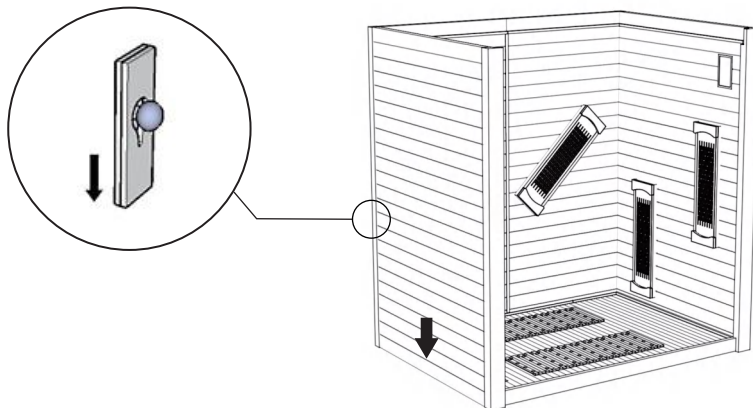

③ Use screws to fix the bottom (there are reserved screw holes).

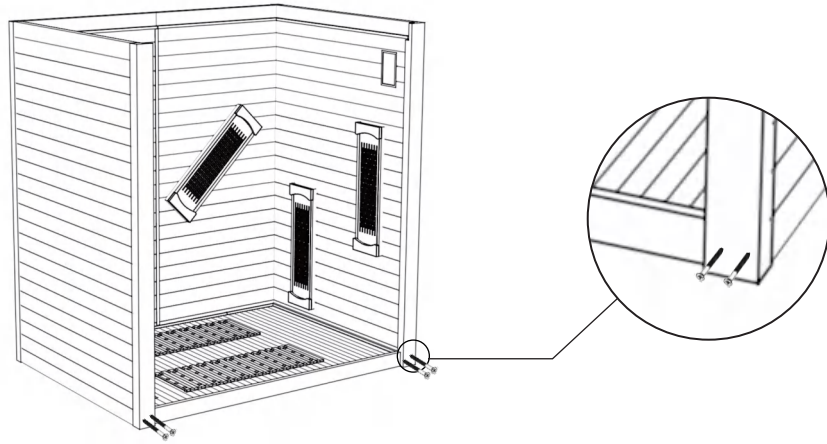

④ Connect the wires.

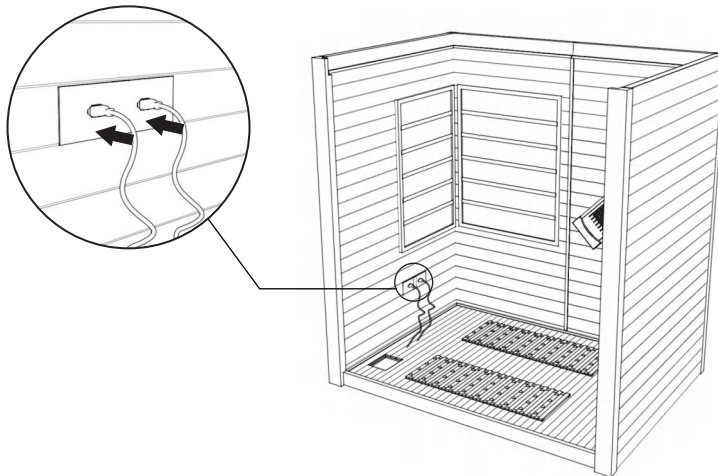

4. Top wall assembly step:

- ① Pass the wires of the side wall of the sauna room through the holes reserved on the top wall, and then place the top wall in the correct position.

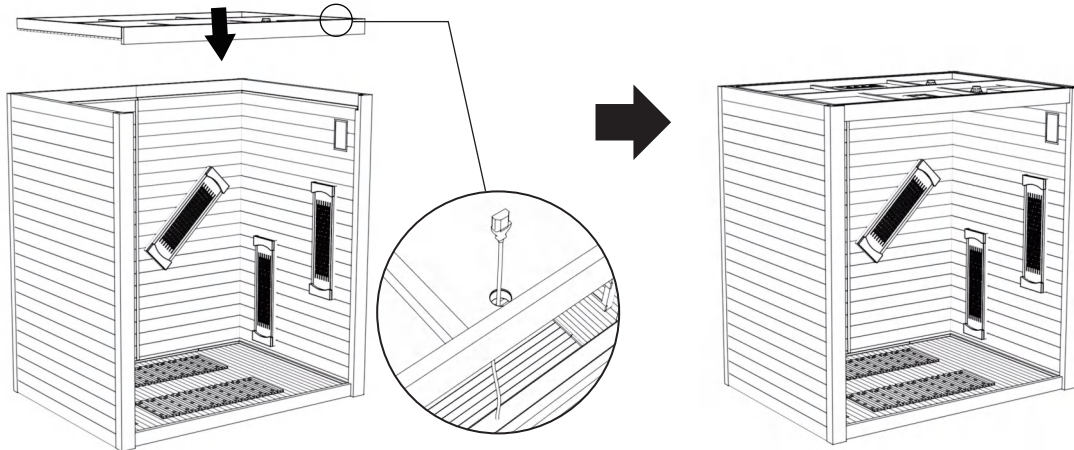

- ② Use screws to fix the top (there are reserved screw holes).

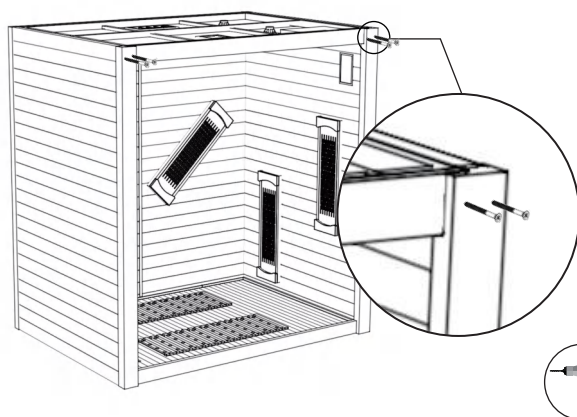

- ③ Connect the wires.

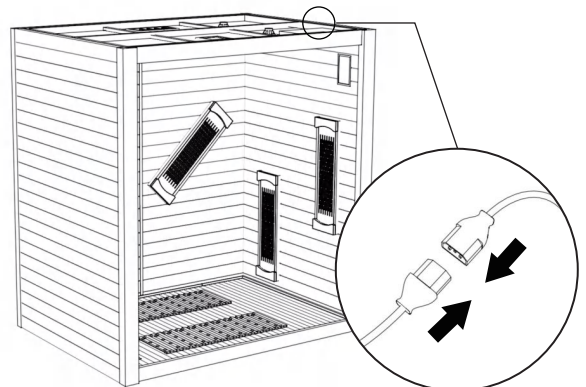

- ④ Open the cover of the electrical box.

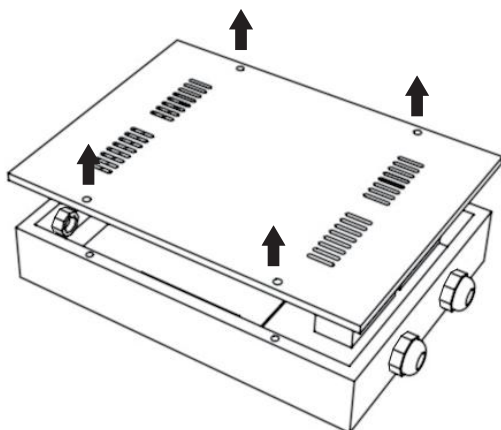

- ⑤ Connect the wires labeled "L", "N", and "E" to the terminals labeled "L", "N", and "E".

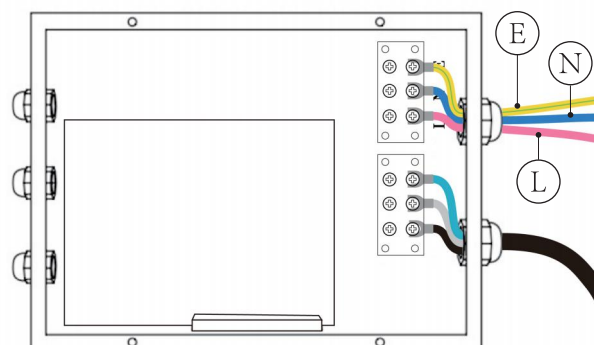

5. Internal accessories assembly step:

(1) Install the Recliner.

① Place the supports as shown in the figure.

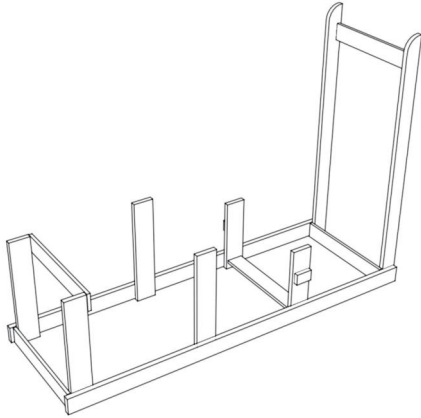

② Place the seat plate on the support.

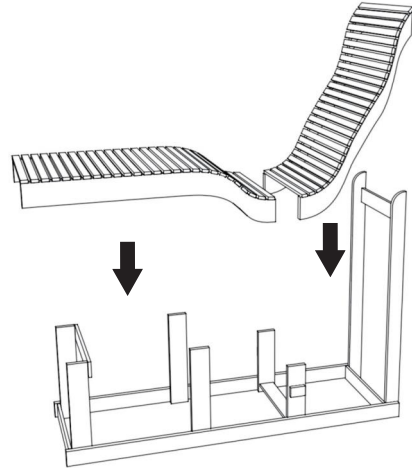

③ Fix with screws (with reserved holes).

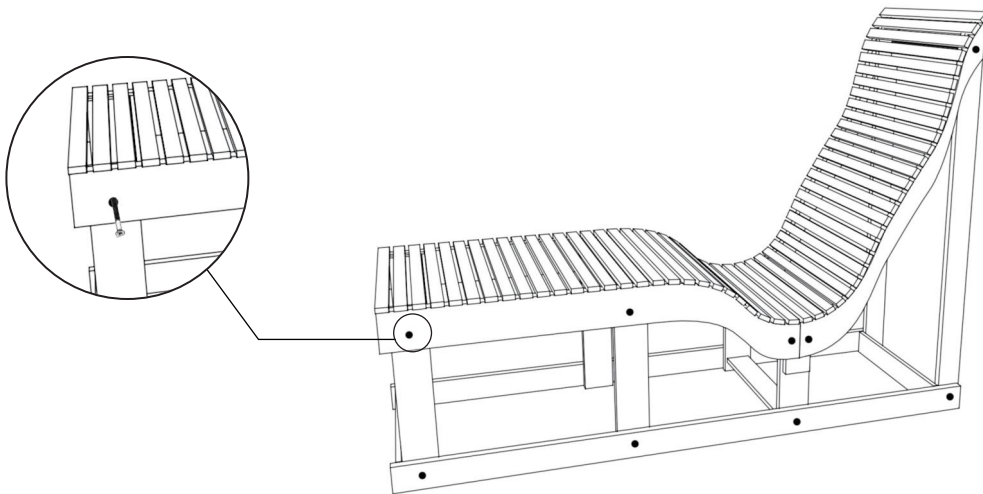

(2) Install the table.

① Fix with screws (with reserved holes).

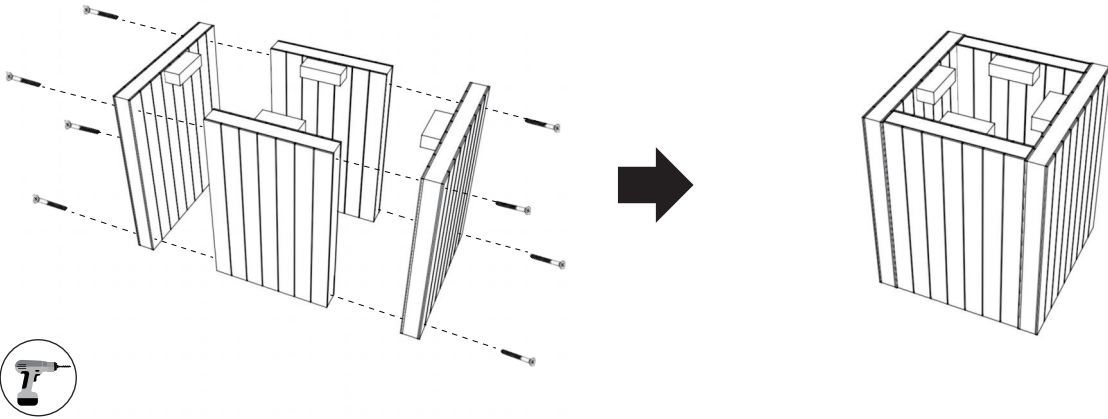

② Turn over.

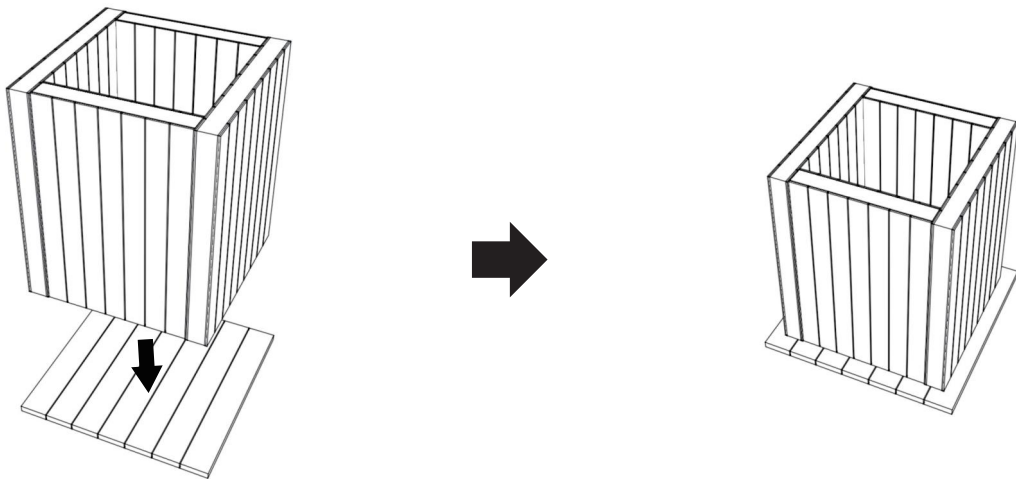

③ Use screws to fix the support and the tabletop.

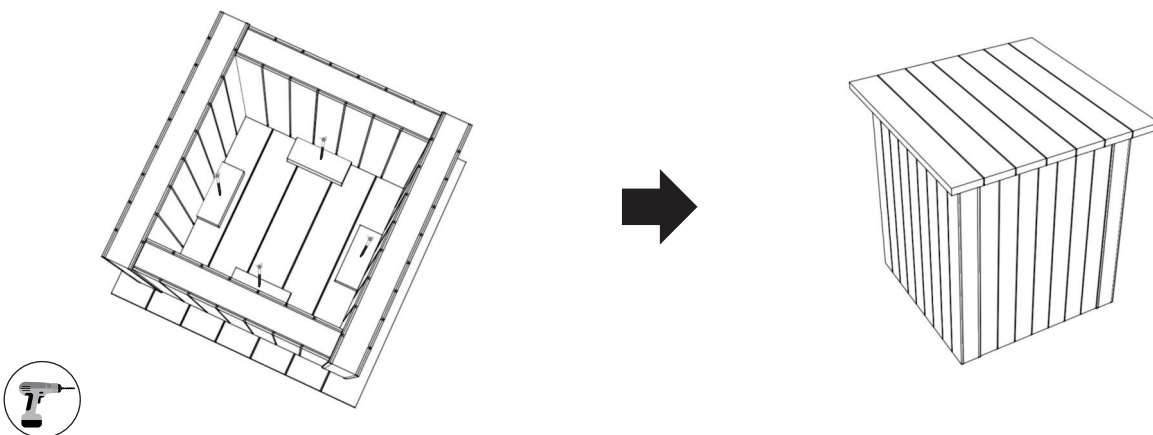

(3) Install the stove and frame.

① Connect the wires of the stove.

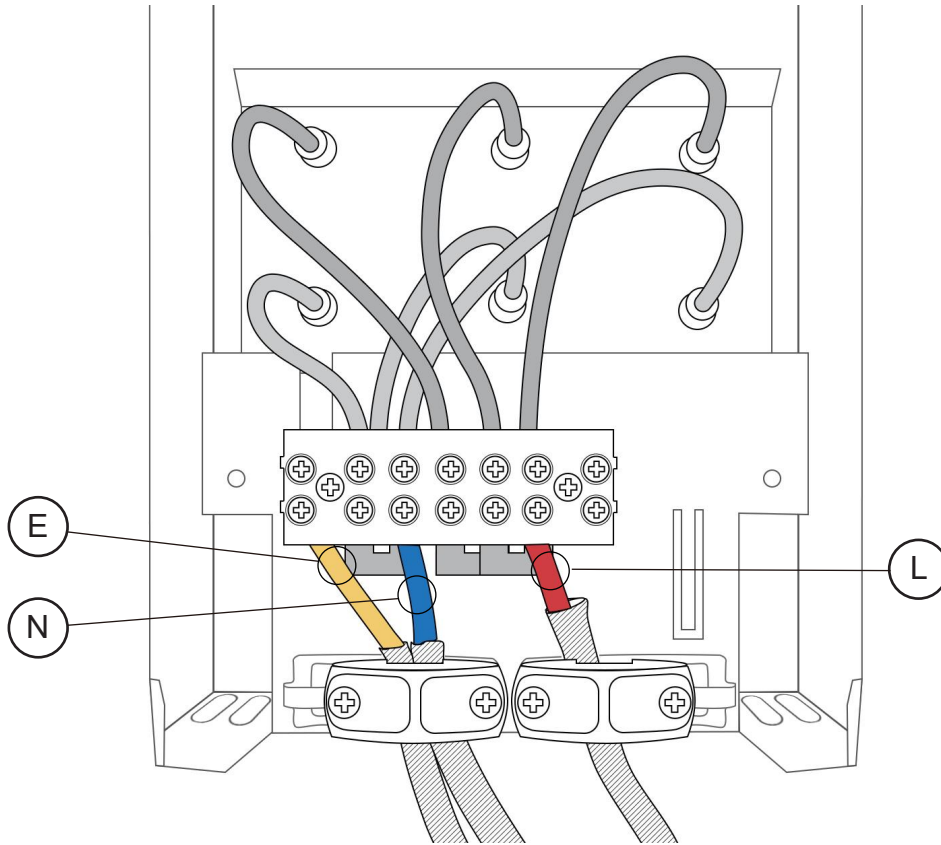

Complete the wiring as picture shown.

② Use screws to fix the frame.

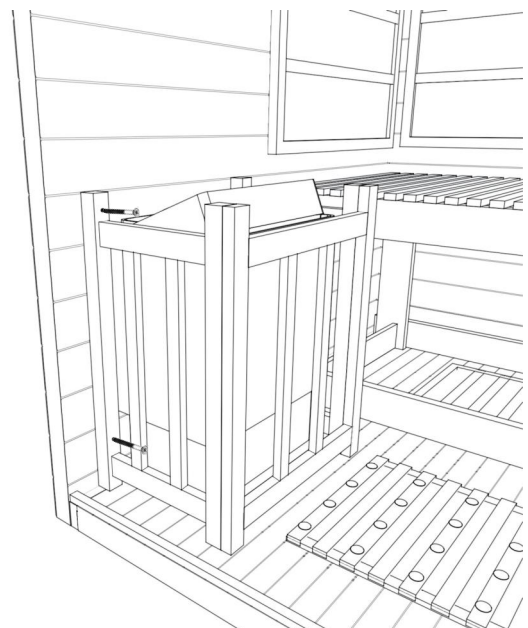
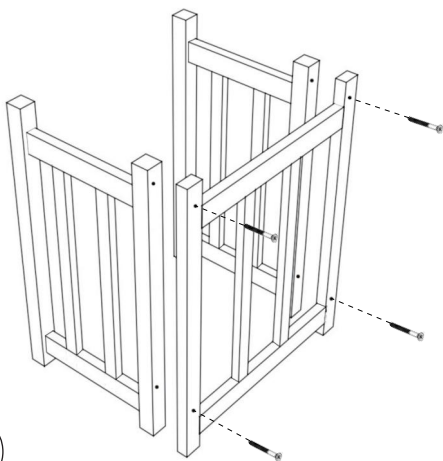

(4) Install the oxygen Ionizer.

① Choose a location and use screws to fix the oxygen Ionizer to the sauna.

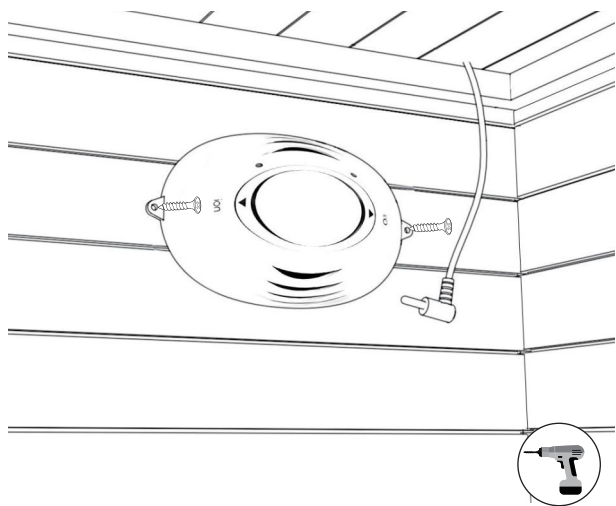

② Connect the top wire to the oxygen Ionizer.

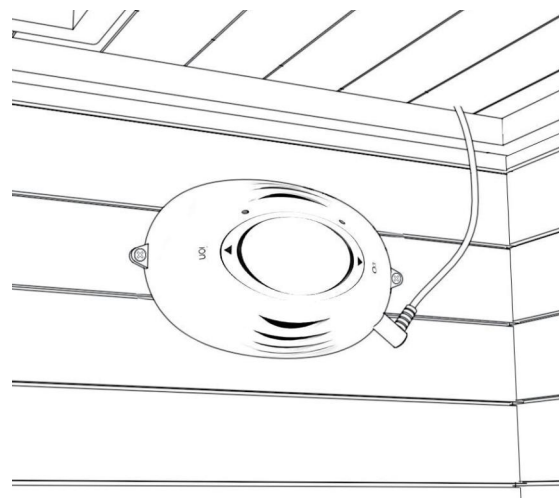

③ Display of inside accessories installed.

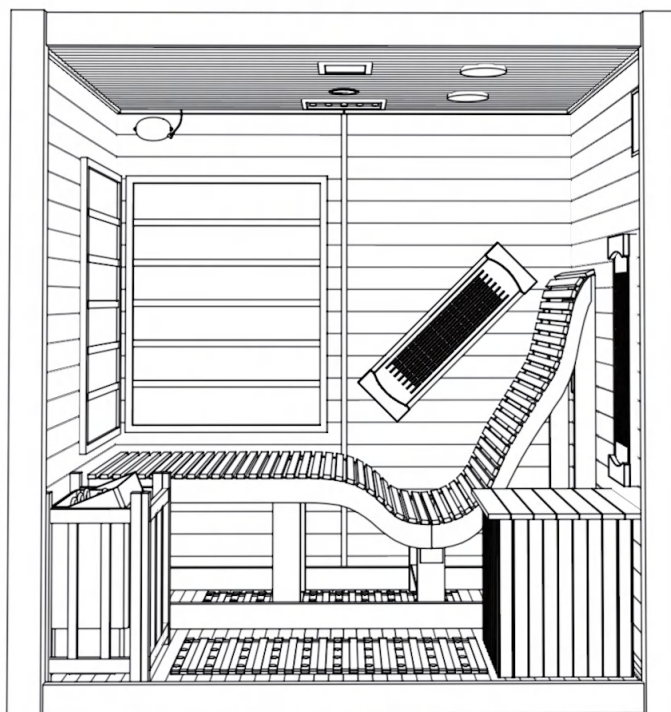

6. Front wall assembly step

① Install the glass to the interior of the sauna front.

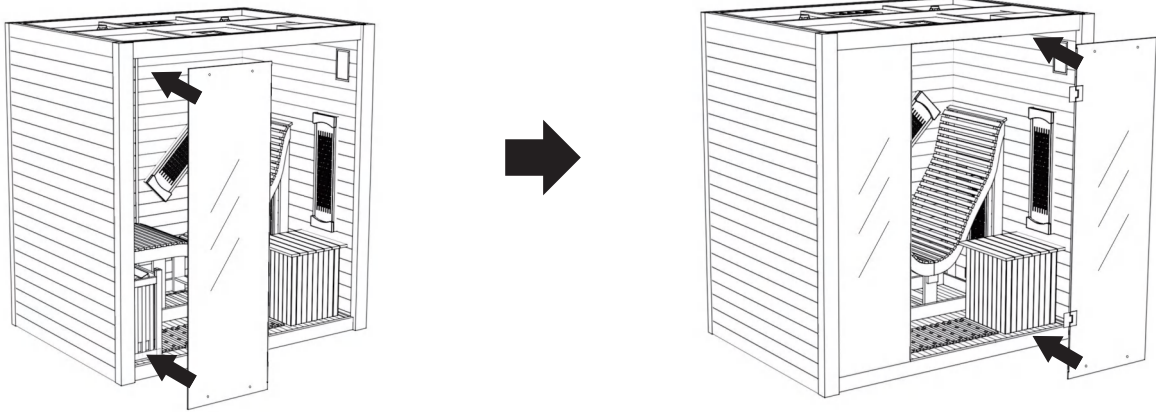

② Fix the glass with screws (there are reserved screw holes).

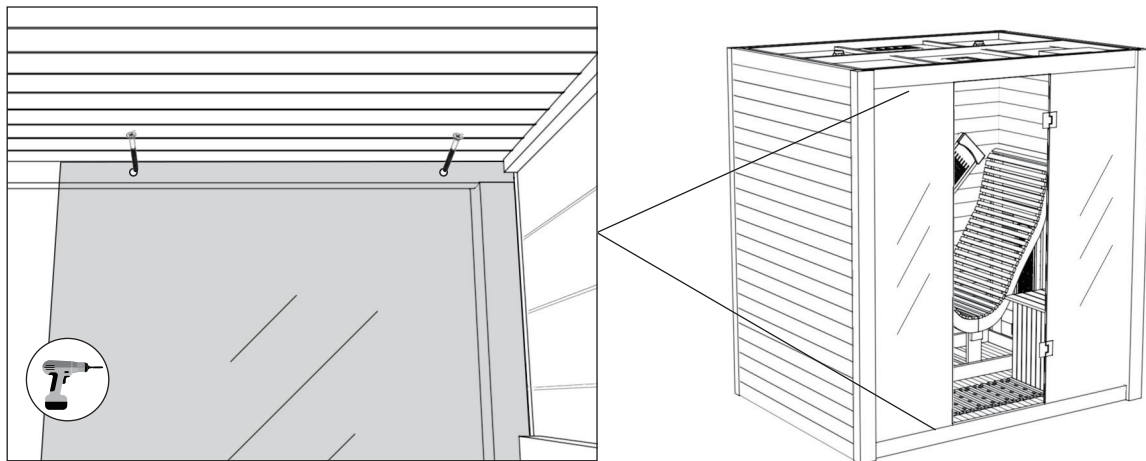

③ Use a hexagonal screwdriver to remove the screw on the hinge, install the glass and fix it with screws.

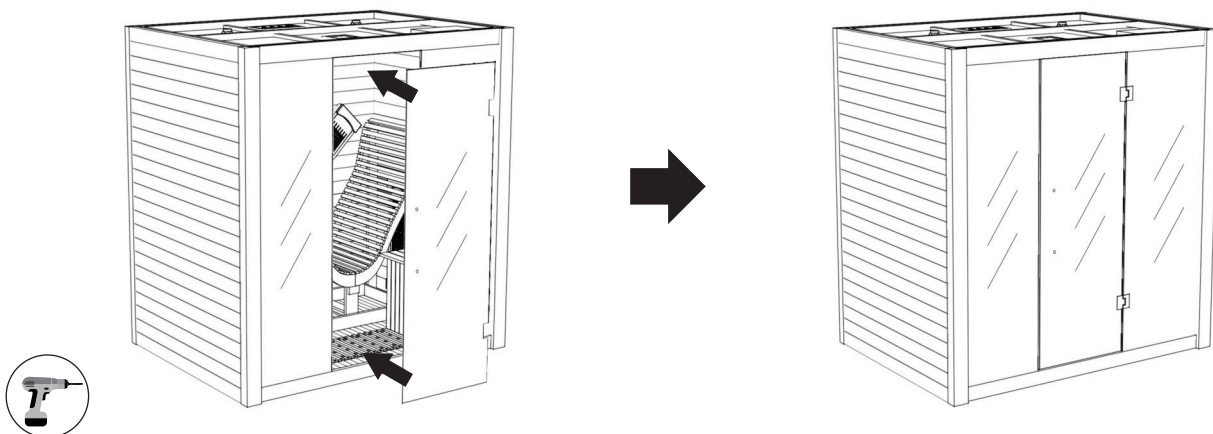

④ Install the door handle.

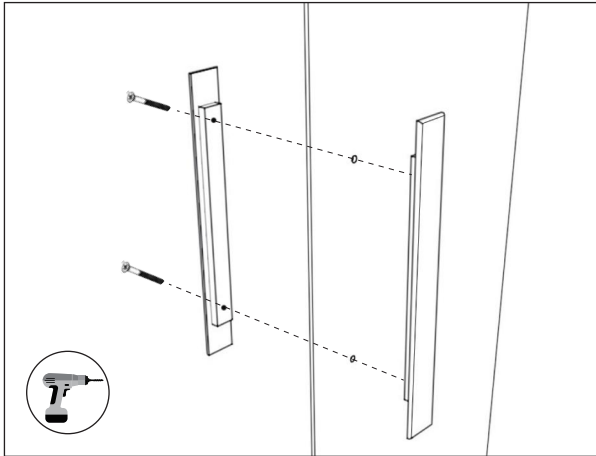

⑤ Assembly completed.

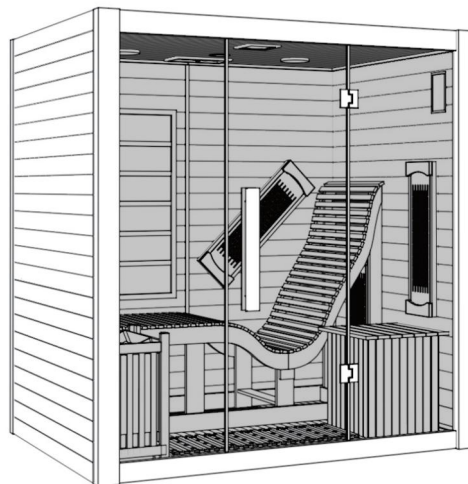

Accessories

Oxygen Ionizer

Locate the ionizer plug that is extended out of the sauna ceiling (1-pin plug). Connect the oxygen ionizer and screw it on the back panel.

The oxygen ionizer is used to refresh the air inside the sauna by killing odor causing bacteria and removing airborne particles.

Use:

Before and while using the sauna, please select the “Ion” option to remove airborne particles by attaching them to the ionizer. After using the sauna, select the “O3” option to kill odor causing bacteria out of the sauna air.



Color Therapy Lights

Some models will include color therapy lights (or chromo lights). The color lights are operated by the remote control only. Press any color on the remote control to turn the lights on and select a color. Press the “Cycle” button (lower right button) to cycle through the colors randomly. Press the “Power” button to turn the lights off.



Sauna Stones

Whether you prefer the steamy atmosphere of a wet sauna or the dry heat of a traditional sauna, these sauna stones offer versatility in all settings. Stones are heated up quickly, and produce and retain steam when you water them. You will be around these white steam, just like in a wonderland, that helps you relax and sweat.



Control Panel Operation Instructions



1	temperature control (reduce temperature) song select control (latter song)	8	timer control (reduce time)/ volume control (reduce volume)
2	temperature control (increase tempure)/ song select control (previous song)	9	timer control (increase time)/ volume control (increase volume)
3	AUX connect interface	10	AUX
4	FM	11	blue tooth
5	USB connect interface	12	Switch far infrared mode/steam mode
6	USB	13	power button (on/off)
7	light	/	/

1. On/Off button

Press the "  " button to turn the sauna on or off. When the power is on, the first press turns the sauna on, and the second press turns the sauna off. After setting the temperature (Infrared: 32-140 °F / Steam: 32-194 °F), the system temperature has a memory function, memorizing the last set temperature value, and the default time is the maximum value of 60 minutes.

2. Temperature setting

After turning on the sauna, press the temperature + and temperature - buttons to adjust the temperature of the light wave. The temperature adjustment range is 86-140°F (infrared) / 86-194°F (steam), with a step of 5; when the temperature is below 86 degrees, it will display -

Fahrenheit and Celsius conversion: Press and hold the TEMP + button for 10 seconds to convert between Fahrenheit and Celsius.

3. Time setting

The time can be adjusted from 5 to 60 minutes, with a step of 1. When the countdown reaches 0 minutes, the buzzer will sound 3 times, with an interval of 1.5 seconds between each sound.

4. Press the "  " button to turn the light on or off.

5. Press the "  " button to turn on the radio function, the temperature area displays the frequency, the clock area displays "XX", the time +/- adjusts the volume, the temperature +/- adjusts the frequency, there is no button response for 8 seconds, and the display switches to temperature and time.

6. Press the "  " button to turn on the AUX function, the temperature area displays AUX, the clock area displays "XX", the time +/- adjusts the volume, there is no button response for 8 seconds, and the display switches to temperature and time.

7. Press the "  " button to turn on the USB function, the temperature area displays USB, the temperature +/- adjusts the previous and next songs, the clock area displays "XX", the time +/- adjusts the volume, there is no button response for 8 seconds, and the display switches to temperature and time.

Note: The USB disk reading time is 2-3 seconds.

8. Click the "  " button, the backlight is on, turn on Bluetooth, turn on the Bluetooth of the mobile device at this time, and search to complete the Bluetooth pairing. After the pairing is successful, you can play songs. The pairing time is 6-7 seconds, the temperature area displays "T B", the clock area displays "XXdb", and the time +/- adjusts the volume. There is no button response for 8 seconds, and the display switches to temperature and time.

Note: During the Bluetooth pairing process, you cannot switch between Bluetooth, USB, and radio immediately. The switching time must be 6-7 seconds. If you switch immediately, you can switch after 6-7 seconds.

9. Press the "  " key to switch between the infrared system and the steam system. For safety reasons, the infrared system and the steam system cannot be started at the same time.

High temperature protection function:

When the sensor's detection temperature exceeds 140 degrees (infrared)/194 degrees (steam), the two digital tubes display HH at the same time, alarm and flash, all functions stop, even if the temperature drops below 140/194 degrees, the function cannot be restored, and the power must be turned off and then on again to use it normally.

Sensor fault detection:

Open circuit: The two digital tubes display " 00 " and flash, the buzzer alarms, the function cannot be turned on normally, and it can be used normally after the fault is eliminated.

Short circuit: The two digital tubes display " 11 " and flash, the buzzer alarms, the function cannot be turned on normally, and it can be used normally after the fault is eliminated.

Temperature sensor failure: The temperature digital tube displays " E0 ", the time digital tube displays normal, the buzzer alarms, and the function cannot be used normally. Check whether the wiring of the temperature sensor is normal. If it is normal, the temperature sensor needs to be changed.

WiFi network configuration:

When the mobile phone APP cannot search for the sauna, you need to debug the sauna without turning on the sauna to put it into network configuration mode.

Family 1 and Family 2 models: long press the "  " button, and hear the "di di di" sound, the sauna room network configuration is successful.

Family 3 and Family 4 models: long press the "  " button, and hear the "di di di" sound, the sauna room network configuration is successful.

Special note: The three major functions of this system, heating, lighting, and sound can be controlled independently and are not related to each other.

Usage Guide

Allow your sauna to warm up for 15-20 minutes or until it reaches 110 °F (43 °C). You may close the vent on the ceiling to speed up the pre-heating process. Drink plenty of water to avoid dehydration before and after the sauna session. It is recommended not to exceed 40 minutes per session.

If the sauna becomes stuffy, open the vent on the ceiling to allow fresh air into the sauna.

Tip:

- Start using the sauna within 10 degrees before it reaches the set temperature in order to receive the most benefits out of the infrared heaters. For example, if you set the sauna to 125 °F (52 °C) degrees, you should start using the sauna when it reaches 115 °F (46 °C) degrees.
- Customers reported an average use temperature of 125 °F (52 °C) degrees.

Precautions

- If the temperature becomes unbearable, decrease the temperature or shut off the sauna immediately.
- Do not use if pregnant or have serious inflammation, a fever, a communicable disease, acute bleeding, or intoxicated.
- Do not consume alcohol or drugs when using the sauna.
- Do not splash water on the heaters or any electrical component inside the sauna.
- Do not bring wet towels into your sauna or any substances that could harm the interior of your sauna.
- Do not install a lock on your sauna.
- All repairs need to be authorized by the supplier's representative; otherwise product warranty may be voided.

Cleaning and Maintenance

Use a clean damp towel to wipe off the bench, floor and around the back panel. Do not use a towel that is too wet and can drip water inside the sauna and do not use cleaning agents inside the sauna.

Make sure to keep the sauna dry and clean. Do not leave towels or water glasses or bottles inside the sauna after use. Wipe the exterior surface of the sauna with a towel and clean the glass at least once a month.

Wood Care

If the sauna exterior body was scratched or scuffed, it can be concealed by using a small amount of furniture polish, oil or other furniture treatment. The interior blemishes, scratches, or scuffs can be either left alone, sanded or combination of gluing plus sanding. Please avoid any treatment containing benzene or a high concentration of alcohol.

Outdoor models body need to be maintain on regular bases (between 6 months to a year) by polishing or resealing the body as needed. If the varnish is cracked or worn off, sand the surface and re-varnish the affected area. Consult your local handyman or furniture repair professional for more details on how to maintain wood in an outdoor environment.

Saunas and Contraindications

Saunas and Medications

Individuals who are using prescription drugs should seek the advice of their personal physician or a pharmacist for possible changes in the drugs effect when the body is exposed to far infrared waves or elevated body temperature. Diuretics, barbiturates and beta-blockers may impair the body's natural heat loss mechanisms. Some over the counter drugs such as antihistamines may also cause the body to be more prone to heat stroke.

Saunas and Children

The core body temperature of children rises much faster than adults. This occurs due to a higher metabolic rate per body mass, limited circulatory adaptation to increased cardiac demands and the inability to regulate body temperature by sweating. Consult with the child's Pediatrician before using the sauna.

Saunas and the Elderly

The ability to maintain core body temperature decreases with age. This is primarily due to circulatory conditions and decreased sweat gland function. The body must be able to activate its natural cooling processes in order to maintain core body temperature.

Saunas and Cardiovascular Conditions

Individuals with cardiovascular conditions or problems (hypertension / hypo tension), congestive heart failure, impaired coronary circulation or those who are taking medications, which might affect blood pressure, should exercise extreme caution when exposed to prolonged heat. Heat stress increases cardiac output, blood flow, in an effort to transfer internal body heat to the outside environment via the skin (perspiration) and respiratory system. This takes place primarily due to major changes in the heart rate, which has the potential to increase by thirty (30) beats per minute for each degree increase in core body temperature.

Saunas and Alcohol

Contrary to popular belief, it is not advisable to attempt to "Sweat Out" a hangover. Alcohol intoxication decreases a person's judgment; therefore they may not realize it when the body has a negative reaction to high heat. Alcohol also increases the heart rate, which may be further increased by heat stress.

Saunas and Chronic Conditions / Diseases Associated With a Reduced Ability to Sweat or Perspire

Parkinson's, Multiple Sclerosis, Central Nervous System Tumors and Diabetes with Neuropathy are conditions that are associated with impaired sweating.

Saunas and Hemophiliacs / Individuals Prone To Bleeding

The use of Infrared saunas should be avoided by anyone who is predisposed to bleeding.

Saunas and Fever

An individual that has a fever should not use any type of sauna.

Saunas and Insensitivity to Heat

An individual that has insensitivity to heat should not use any type of sauna.

Saunas and Pregnancy

Pregnant women should consult a physician before using any type of sauna because fetal damage can occur with a certain elevated body temperature.

Saunas and Menstruation

Heating of the low back area of women during the menstrual period may temporarily increase their menstrual flow. Some women endure this process to gain the pain relief commonly associated with their cycle whereas others simply choose to avoid saunas use during that time of the month.

Saunas and Joint Injury

If you have a recent (acute) joint injury, it should not be heated for the first 48 hours after an injury or until the hot and swollen symptoms subside. If you have a joint or joints that are chronically hot and swollen, these joints may respond poorly to vigorous heating of any kind. Vigorous heating is strictly contra-indicated in cases of enclosed infections be they dental, in joints or in any other tissues.

Saunas and Implants

Metal pins, rods, artificial joints or any other surgical implants generally reflect far infrared waves and thus are not heated by this system; nevertheless you should consult your surgeon prior to using an Infrared Sauna. Certainly, the usage of an Infrared Sauna must be discontinued if you experience pain near any such implants. Silicone does absorb far infrared energy. Implanted silicone or silicone prostheses for nose or ear replacement may be warmed by the far infrared waves. Since silicone melts at over 200°C (392°F), it should not be adversely affected by the usage of Infrared saunas. It is still advised that you check with your surgeon and possibly a representative from the implant manufacturer to be certain.

In the rare event, you experience pain and/or discomfort, immediately discontinue sauna use.

Troubleshooting

The sauna doesn't power on

- Make sure the power cord is securely connected to the power socket and the control box (on top of the sauna).
- Make sure the breaker did not turn off.
- Make sure the control panel white ribbon wire is securely connected.
- Make sure the power socket is working by trying a different device on the same socket.

Light is not working

- Replace the light bulb.

Color therapy light does not work

- Make sure the battery is inserted correctly.
- Make sure to point the remote directly at the remote receiver (small rounded tip next to the color lights).
- Try a new battery.

All heaters are not working

- Make sure to connect the heaters plugs are connected securely to the control box (on top of the sauna).
- Make sure the sauna is connected to the recommended power supply.
- Make sure the heat sensor is connected securely.

One or few heaters are not working

- Make sure to connect the heaters plugs are connected securely to the control box (on top of the sauna).
- Make sure to connect the heaters plugs under the bench are connected securely.
- Floor heater and under bench heater are not as hot as other heaters (by design).
- Make sure the plug behind the heater is connected (you would need to unscrew the heater).

Control panel display is unusual

- If the control panel temperature display is over 150 or 230, make sure to connect the heat sensor securely.
- If the control panel time display is -- (two dashes), the sauna is on continues working mode. Press the timer button to return to timed working mode.

For more troubleshooting advice or to report a problem, please contact with the supplier

Our story

IDOTODO was born out of a passion for improving health and wellbeing. As a high-tech enterprise, Smartmak has been committed to the production, research and development, sales and service of home therapy sauna rooms and related products since 2005. The company firmly believes in the power of technology to improve people's health and quality of life.

IDOTODO's commitment to wellness is reflected in every aspect of its business. From the strict quality control measures implemented during the production process to the comprehensive after-sales services provided, Smartmak always puts the well-being of its customers first. The company's products are designed with health and wellness in mind, utilizing the latest technology and innovative materials to create safe and effective home therapy saunas.

IDOTODO's dedication to wellness goes beyond its products and services. The company is actively involved in promoting healthy lifestyles and educating the public about the benefits of home remedies saunas. By partnering with wellness organizations and experts, Smartmak is helping to raise awareness of the importance of physical and mental health, and the role innovations like the home therapy sauna can play in achieving optimal health.

IDOTODO's vision is to empower everyone with access to the tools and technology they need to achieve optimal health and well-being. With a commitment to quality, innovation and wellness, Smartmak is not just a brand, but a beacon of hope for those seeking to improve their lives through the power of technology.

Warranty Policy

Dear customer:

First of all, thank you for choosing to buy our products!

In order to ensure product quality, specify product quality.

The responsibility of both parties is to ensure that the product quality is qualified, and to ensure product safety, the following guarantees are hereby made:

Warranty scope:

All accessories in the sauna room including wooden planks and slats, etc.

Warranty period for wooden planks, wooden accessories (stools, backrests, headrests) :
3 years from the date of arrival;

Warranty period for lamps, control boards, oxygen bars, reading lights, etc.: 3 years from the date of arrival.

Warranty:

(1) During the 1-year warranty period, in the case of non-human damage, all accessories, free replacement, and the shipping cost will be borne by the seller.

(2) During the 1-year warranty period, if all accessories are due to human factors, our company will be responsible for free replacement, and the freight will be borne by the buyer.

(3) During the warranty period of more than one year (not including one year), if all accessories are damaged due to non-human factors, our company can replace them for the customer at the cost price, and the freight will be borne by the seller.

(4) During the warranty period of more than one year (not including one year), if all accessories are damaged due to human factors, our company can replace them for the customer at the cost price, and the freight will be borne by the buyer.

The final interpretation of this warranty policy belongs to the company.